

Husqvarna

DS160C

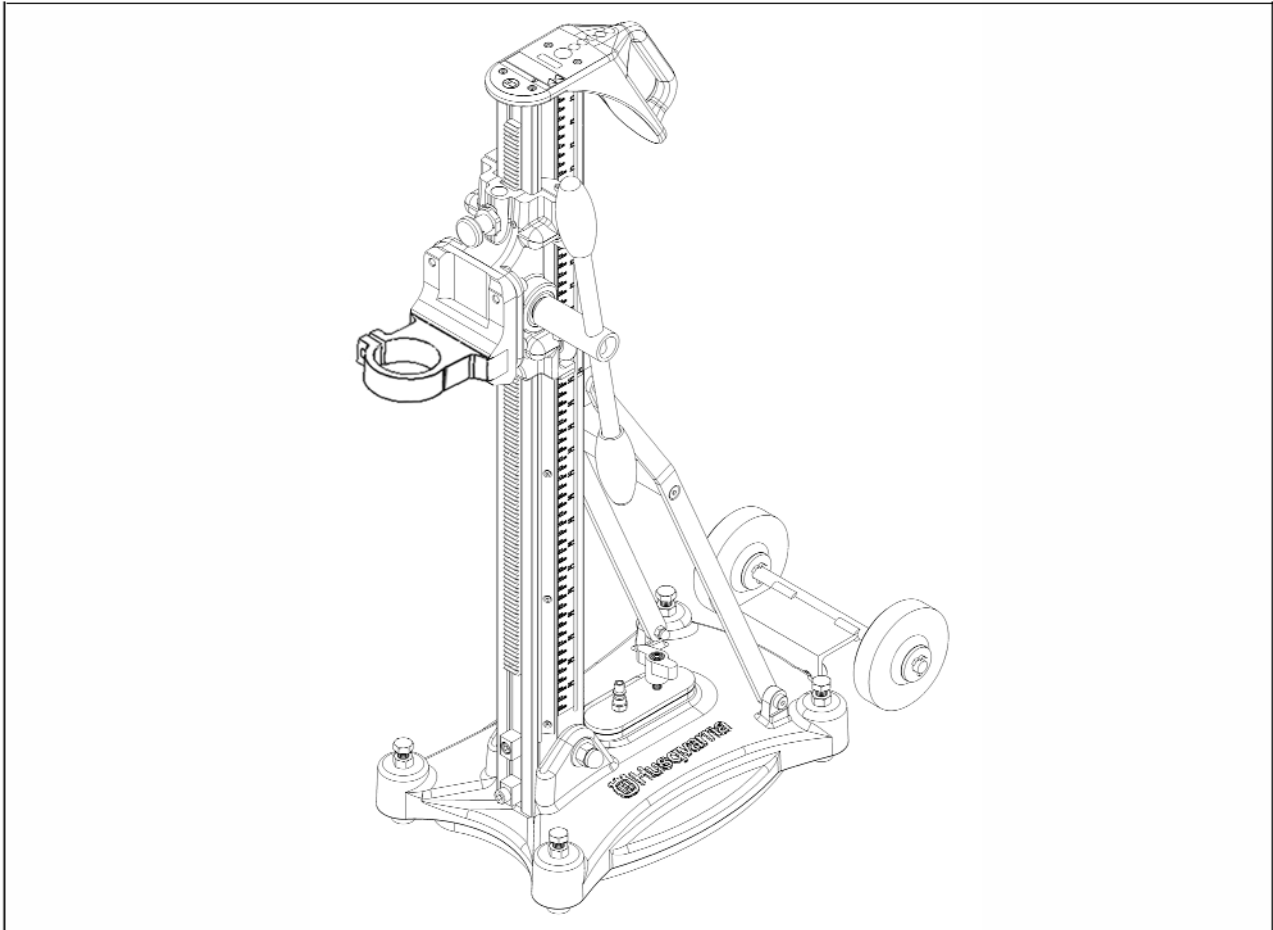

Manuel d'utilisation et d'entretien
Foreuse de chantier

Manuale di Istruzioni
Trapanatrice da cantiere

Manual de Instrucciones
Taladradora de obra

Operating Instructions
Drilling Machine

Betriebs-und Wartungsanleitung
Baustellen-Bohrmaschine

Gebruiksaanwijzing
Verplaatsbare Boormachine

Manual de Instrucoes
Perfuradora de obra

Bruksanvisning och Underhallsmanual
Borrmaskin

P/N 541404170
8/2006

DECLARATION OF CONFORMITY WITH EUROPEAN DIRECTIVES
DECLARACIÓN DE CONFORMIDAD CON LAS DIRECTIVAS EUROPEAS
DÉCLARATION DE CONFORMITÉ AUX DIRECTIVES EUROPEENNES

MANUFACTURER herewith declares that the machine designed hereunder
EL FABRICANTE declara que la máquina descrita a continuación
LE FABRICANT déclare que la machine désignée ci-dessous

DS160C

**HUSQVARNA CONSTRUCTION PRODUCTS
NORTH AMERICA
17400 West 119th Street
Olathe, Kansas 66061
USA**

**HUSQVARNA CONSTRUCTION PRODUCTS
433 81 Partille
SWEDEN**

conforms to the modified "MACHINES" Directive (98/37/CE),
the "LOW VOLTAGE" Directive (73/23/CEE) the "EMC" Directive (89/336/CEE) in
accordance with European standards EN 50081/1 and EN 55022
and the "NOISE" Directive (2000/14/CEE) in accordance with European
standards EN ISO 3744

conforma a las "MAQUINAS" Directivo de modificadas (98/37/CE),
el "VOLTAJE BAJO" Directivo (73/23/CEE) el Directivo "EMC" (89/336/CEE)
en acuerdo con el estándar de Europa EN 50081/1 y EN 55022 y el Directivo de "RUIDO"
(2000/14/CEE) in acuerdo de estándar de Europa
EN ISO 3744

est conforme aux dispositions de la directive "MACHINES" modifiée (98/37/CE),
la directive "BASSE TENSION" (73/23/CEE) la directive "CEM"
(89/336/CEE) suivant les normes européennes EN 50081/1 et EN 55022
et la directive "BRUITS" (2000/14/CEE) suivant les normes européennes
EN ISO 3744

James H. McMenemy
Vice President, Operations

 **WARNING**

Some dust created by power sanding, sawing, grinding, drilling and other construction activities contains chemicals known to cause cancer, birth defects or other reproductive harm. Some examples of these chemicals are:

- Lead from lead-base paints,
- Crystalline silica from bricks and cement and other masonry products and
- Arsenic and Chromium from chemically treated lumber.

Your risk from these exposure varies, depending on how often you do this type of work. To reduce your exposure to these chemicals: work in a well ventilated area and work with approved safety equipment, such as those dust masks that are specially designed to filter out microscopic particles.

·REFER TO MANUAL·

PREFACE TO THE MANUAL

These operating instructions apply exclusively to drill stand, type DS 160 C. Please also read the operating instructions that accompany your drill motor to verify their compatibility and not to exceed the limitations of the DS 160 C drill stand.

Usage to the Intended Purpose

The drill stand is designed exclusively for core drilling in concrete, asphalt, brickwork or similar building materials. Details of the maximum permissible drill bit diameter can be found under "Technical Specifications". Any use above and beyond the intended purpose endangers both user and machine and is not permitted.

Before commencing drilling, always ensure that;

there is no danger of drilling through electric cables, gas, oil or other pipes,
the drilled holes do not undermine the stability of the structure,
you do not drill into or through any steel girders,
when drilling through walls, you cannot cause any damage at the drill exit point.
Strict care must be taken when drilling in areas where people or general public
are present. Local codes dictate proper protocol and must be observed.

Improper Usage

The drill stand must not be used for any kind of stirring, e.g. paint or similar;
drilling holes in soil, e.g. to drill holes for posts.

The drill stand must be mounted via anchor bolt or vacuum, do not attempt to
drill hand held or standing on base plate.

This drill stand incorporates the expertise of decades of experience in the field of concrete drilling.

Before leaving our factory every machine passes an inspection program in which everything is checked completely.

Following the instructions will ensure that your machine gives long service, in normal operating conditions.

The user advice and spare parts mentioned in this document are given as an indication and do not constitute an undertaking. No warranty will be granted in the event of errors or omissions or for damage occurring during delivery or caused by the design or use of this machine. We are very concerned about the quality of our products and we serve the right to make any technical modifications to improve them without warning.

This document will assist the user particularly in:

- Information about the machine
- Information about its possible uses

- Prevent accidents due to unsuitable use, by an untrained person, during maintenance, repairs, overhauls, handling or transport
- Improve the reliability and durability of the machine
- Ensuring correct use, regular maintenance and rapid repair in order to reduce stoppage times and repair cost.

**The manual should always be available at the place of work.
It should be read and used by any person installing or using the machine.
The obligatory technical regulations in force in the county where the machine is used
must also be adhered to for maximum safety.**

GENERAL SAFETY INSTRUCTIONS

The use of symbols on the drill stands and in the manual identify advice concerning your safety.



This symbol indicates that the machine is in conformance with the applicable European directive.



WARNING



MANDATORY



PROHIBITED



INFORMATION

These signs give advice concerning your safety.

SPECIAL INSTRUCTIONS

- The drill stand is designed to provide safe and reliable service in operating conditions corresponding with the instructions, but it can present dangers for the user and risks of damage, consequently regular on site inspection is necessary to ensure:
- Perfect technical condition (use for the purpose for which it is intended and taking into account any risks and correction of any malfunction detrimental to safety).

- Use of a diamond core bit for water lubricated cutting of concrete, asphalt, marble, stone, granite, brick and facings (porcelain, glazed tiles, ceramics, etc). The use of any other core bit is forbidden (abrasive, saw, etc).
- Competent staff (qualifications, age, training) who have read and understood the manual in detail before starting work: any electrical, mechanical or other problem should be investigated by a qualified maintenance engineer (electrician, maintenance manager, approved dealer, etc).
- That the warnings and instructions marked on the machine are followed (adequate personal protection, correct use, general safety instructions, etc).
- That no modification, transformation or addition is detrimental to safety and that it is carried out without prior authorization from the manufacturer.

MOTORS:

DIMAS: DM 225D with motor support collar
DM 225 with motor support collar

WEKA: DK 12 with motor support collar
DK 13 with motor support collar
DK 14 with motor support collar

CARDI: Talpa T0 with motor support collar
Talpa T1 with motor support collar

Motor characteristics: see the manufacturer's manual supplied with the motor.

Please contact us regarding any other frame/motor combination.

1. Delivery

On delivery, carry out an immediate visual check for signs of physical damage and that no components are missing.

The contents of the package should include:

Drill Stand - Base, Column, Carriage, Crank, Wheel Assembly, Vacuum Cap Plate, Vacuum Gasket and Back Support, Operating Instructions and Ordered Accessories.

2. Technical Specifications

Base length 15.50 in / 394 mm

Base width 9.50 in / 241 mm

Height 32 in / 813 mm

Weight 30 lbs / 14 kg

Motor rating up to max. 3.5 hp / 2.4 kW

Drill bit diameter up to max. 6 in / 152 mm

Impact anchor; minimum tensile force 5.7 kN with M12 Fastener

3. Assembly

Align holes on the wheel assembly (1) with the tapped holes on rear of the base plate (2). Insert bolts (3) through lockwashers (4), then insert bolts through wheel assembly and screw onto base plate.

4. Description and Features of the Drill Stand

Tapered roller carriage.
Sealed ball bearing design.
Plumb and leveling guides.
Left and right crank handle drive with incorporated adjustment tool. This adjustment tool adjusts column angle, leveling screws and column angle lock.
Angle column capability.
Anchor base with incorporated vacuum capability.
Detachable wheel assembly.
Replaceable wear items.
Incorporated carrying handle.
Column angle and drill depth indicator decal.
Rigid drill collar motor mount.
Brass inserts for leveling bolts.
Precision rack and pinion drive.

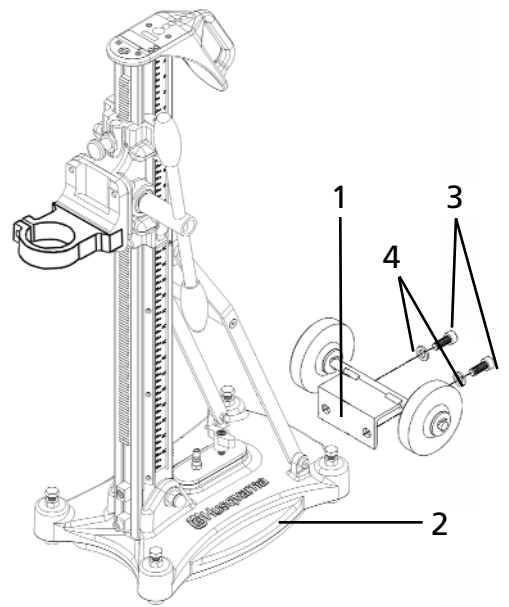

5. Handling - Transport

Remove the diamond core bit from the drill motor.
Remove the motor from the carriage assembly.
Lower the carriage to the base and lock the brake.
The transport wheels enable the drill stand to be moved easily.
Tilt the drill stand backwards and hold the handle at the top of the column.
To avoid damaging the motor shaft, the motor must not be carried or moved by the shaft, whether or not it is fitted with a drill or extension.
If the base is to be used as a vacuum mount, do not move the drill stand laterally or damage and tearing away the vacuum seal may result. To avoid deforming the seal, remove the seal when vacuum is not in use.

6. Inspection Before Starting Up



Please read the instructions for use prior to operating the machine for the first time.



The working area must be completely cleared, well lit and all safety hazards removed (no water or dangerous objects in the vicinity).



The use of ear protection is mandatory.



The operator must wear protective clothing appropriate to the work he is doing. We recommend that this includes both eye and ear protection.



Any person not involved in the work should leave the working area.

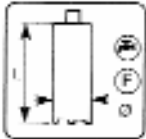

Use core bits which are suitable for the work to be done.

7. Fitting and Removing the Motor



Unplug the motor from the outlet.



Always remove the core bit before fitting or removing the motor.

Engage the carriage brake. The motor is mounted on the frame by means of a support collar.

8. Electrical Connection



ELECTRICAL SAFETY:



Operate this machine only on a supply equipped with a 30 mA grounded current-limiting circuit breaker.



The Ground Fault Circuit Interrupter (GFCI) must be used correctly, including testing it regularly. For tools supplied with an integral GFCI in the cable or in the main plug, if the cable or plug has been damaged, repairs must be carried out by the manufacturer, one of his agents or by a qualified repair workshop to avoid any risks resulting from errors.



Use single phase 2 pole plus grounded sockets for the appropriate voltage.



Make sure that the main voltage is the same as that on the manufacturer's plate.

Extension cables, type HO7 RNF, should have an adequate cross section for the power: 3 x 2.5 mm² up to 50 m or double for longer cables.

9. Mounting Methods

There are three options available for fastening the base plate of your drill stand. Fastening with threaded rod and heavy-duty anchor, expanding anchor or vacuum.

10. Designation of the Components

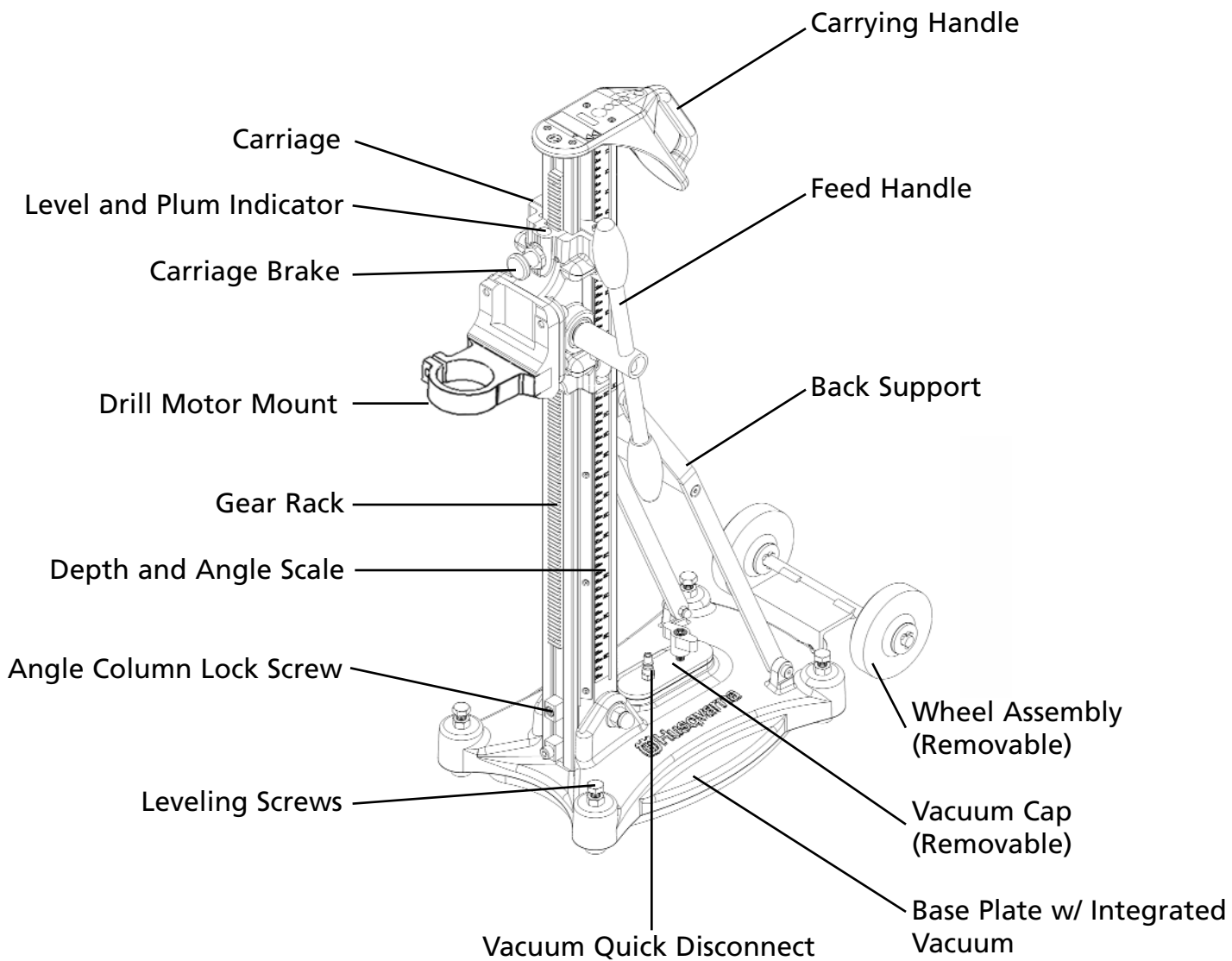

11. Operation Positions

The drill stand can be used for drilling ceilings, floors and walls. Individual safety instructions for each area of applications as described in the following chapters must be observed and complied with.

The three main drilling directions (area of application) are:

Floor position: The feed direction is vertical and downward.

Wall position: The feed direction is horizontal.

Overhead position: The feed direction is vertical and upwards.



Floor Positions

A falling core can cause serious injury. The danger zone underneath the drilling area must be sealed off and the core must be supported.



Wall Position

Before drilling into a wall, the operator must ensure that there are no obstructions at the exit point and that there is no risk of injury.



Overhead Drilling

It is not permitted to secure the drill by means of the vacuum plate when carrying out overhead drilling. Follow local codes for anchoring overhead. Overhead drilling may only be carried out if a water collector and vacuum collection system is used. During overhead drilling, only use impact anchors suitable for zones subject to tensile force.



Angle Drilling

When angle drilling, always work at low drilling pressure until the drill bit is completely engaged.

12. Fastening the Drill Stand (Base Plate)

There are three options available for fastening the base plate;

Fastening with threaded rod and heavy-duty anchor or impact anchor;

Fastening by means of a threaded rod and locking nut with washer;

Fastening by means of a vacuum plate and vacuum pump.

Fastening by means of a Threaded Rod and Heavy-Duty Anchor or Impact Anchor

Fastening the drill stand base plate should be carried out without the drill motor installed.

To ensure that the device is securely fastened, only use heavy-duty anchors or impact anchors approved by the building inspection authorities which may vary by country, province, county or city. When working overhead, only use anchors suitable for zones subject to tensile force. For details of minimum tensile force, see, "Technical Specifications".

Drill a hole for the anchor at a distance of 292 mm (X) from the hole center.

Drive the impact anchor and secure.

Screw in the all thread rod (2).

Slip on the base plate (4) over the thread rod.

Fit the washer and tighten nut (1) slightly.

Align the base plate (4) by means of the adjusting screw (3).

Tighten nut (1).

Fastening by means of a Thread Rod, Washer and Lock Nut

If, for any reason, the anchoring surface does not provide sufficient hold for the anchor, a thread rod must be used which passes through the brickwork, the wall or the ceiling and is secured from the other side by means of a washer and locknut.

Fastening by means of a Vacuum Plate

It is not permitted to fasten the drill stand by means of a vacuum when carrying out overhead drilling.

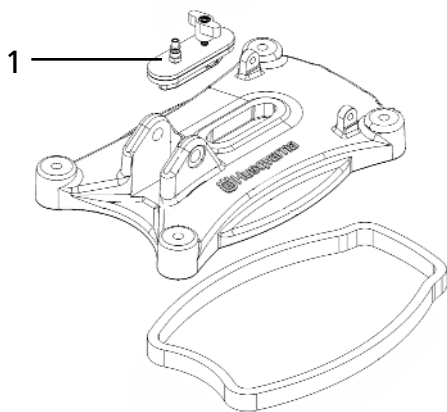
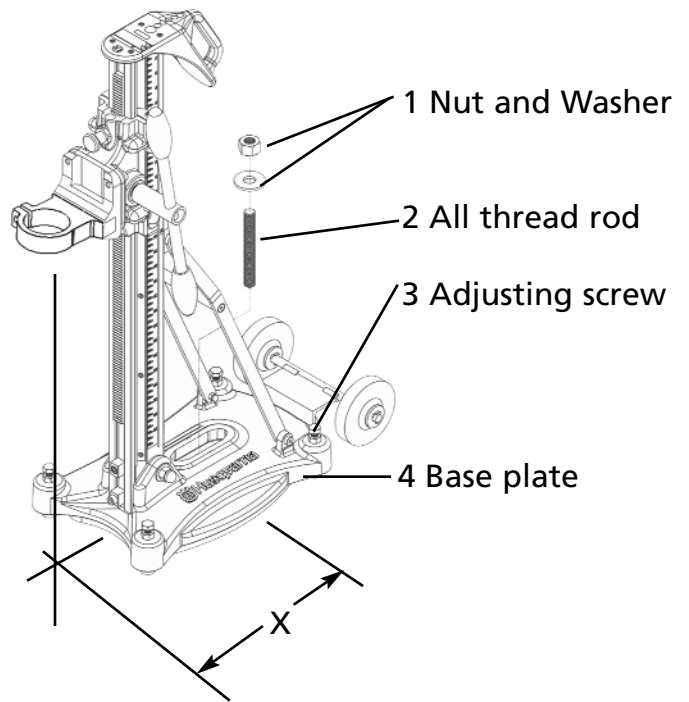

Vacuum Cap, Base Plate and Gasket

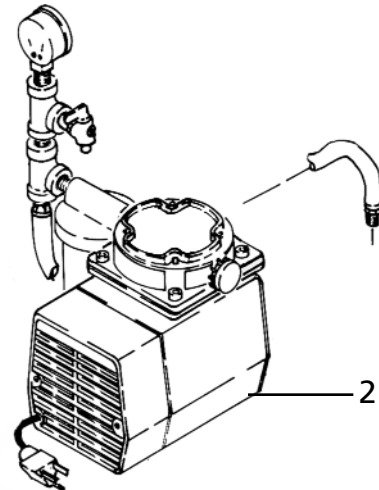

Vacuum Pump
(Actual pump may vary between Regions)

Connect the vacuum hose to the vacuum cap (1) and switch on the vacuum pump (2). Set the vacuum base at the measured position and prime. A vacuum of at least 25 in.Hg must be reached or until the plate is properly secure. Because this type of fastening depends on the surface, it can only be implemented on smooth, level and non-porous surfaces. When fastening the drill stand, it must be ensured that the floor covering is firmly attached to the undersurface and cannot work its way loose.

13. Setting the Angle of the Column

Remove the column lock bolt (1)

Loosen bolt on back support bracket (2).

The column can now be pulled into the desired position, 0 to 45 degrees. Side decal provides approximate measurements. If greater precision is required use alternate measuring techniques. Maximum column range is 45 degrees. Indicator strip on the column shows various degrees (3).

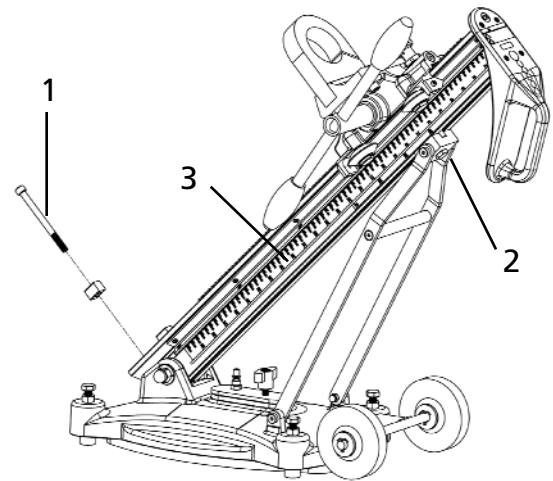

14. Mounting the Drill Carriage



Risk of injury!

Always disconnect the power before mounting the drill carriage to the drill motor. Fingers may be crushed between the column and drill carriage. For this reason, when mounting the drill carriage, keep one hand on the handle and the other hand on the drill motor.

Align the column.

Mount the drill carriage.

15. Operating the Feed



Drilling into a live external power supply line can cause a fatal injury as the drill may conduct current and voltage. A Ground Fault Circuit Interrupter (GFCI) offers no protection in such situations, therefore care must be taken prior to drilling to ensure that electrocution is avoided.



The use of levers or extensions to increase drilling pressure is prohibited. In order to prevent the drill bit being damaged, it is important to ensure that the diamond core bit is supplied with sufficient cooling water. Operate the feed handle manually.

The feed handle is designed to facilitate handling of the drill and its flexible left/right hand fitting enables convenient adaptation to individual drilling situations. The feed handle can be switched to the other side as follows:

Pull off the feed handle in an axial direction.

Slip the feed handle onto the axle shaft on the opposite side.



A loose feed handle on the shaft may cause you to lose control of the drill. For this reason, always ensure that the feed handle is securely fitted on the shaft.

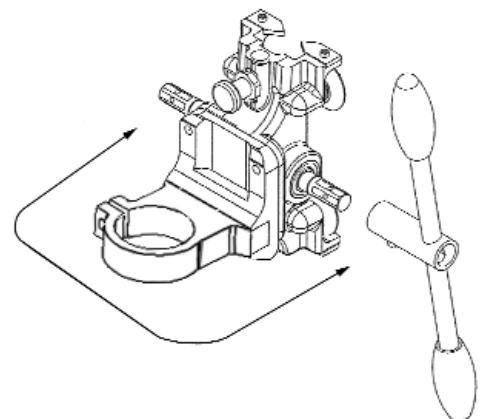

16. Maintenance

For details of maintenance work required for the drill motor, please refer to the enclosed motor manufacturer's documentation.

Routine Checks

Check electrical connections routinely before each use.

The following routine checks should be carried out monthly:

Check that all screws and fastening elements are properly secure.

Check the feed handle for easy movement.

Check the drive for easy movement and noise.

Check the column for wear and damage.

Check for movement or play in the drill carriage.



Always disconnect the electrical plug before cleaning your drill stand. The drill is virtually maintenance-free and only requires cleaning. Never clean the drill motor with water or excessively wet clothes.

Adjusting Carriage

Rollers

Loosen the locknut (1) using a 19mm open end wrench, turn the eccentric shaft (2) using an 8mm open end wrench, so there is only slight pressure of the roller in contact with the column wear plates (3). Holding the eccentric shaft in place, tighten the locknut. Follow this procedure for both adjusting rollers.

If you are unable to achieve proper adjustment, the rollers and/or column wear plates may need to be replaced.

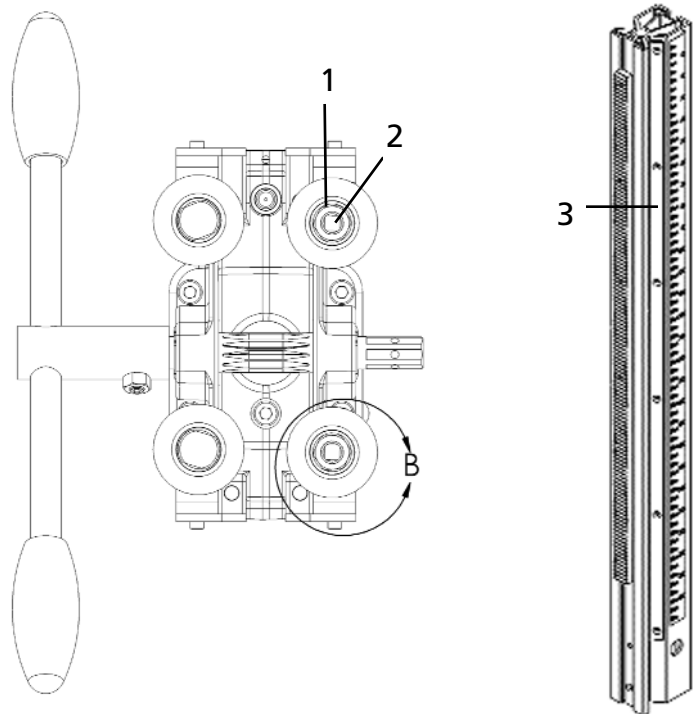

Wear Cylinders

Using a 4mm allen wrench, turn each of the 4 setscrews (4) clockwise until the nylatron wear cylinders (5) are in slight contact with the column.

Side Cleaning Plates

Loosen each of the 4 cleaning plate capscrews (6) using a 3mm allen wrench and slide the cleaning plate (7) so it is in contact with the column wear plates. Tighten the capscrews.

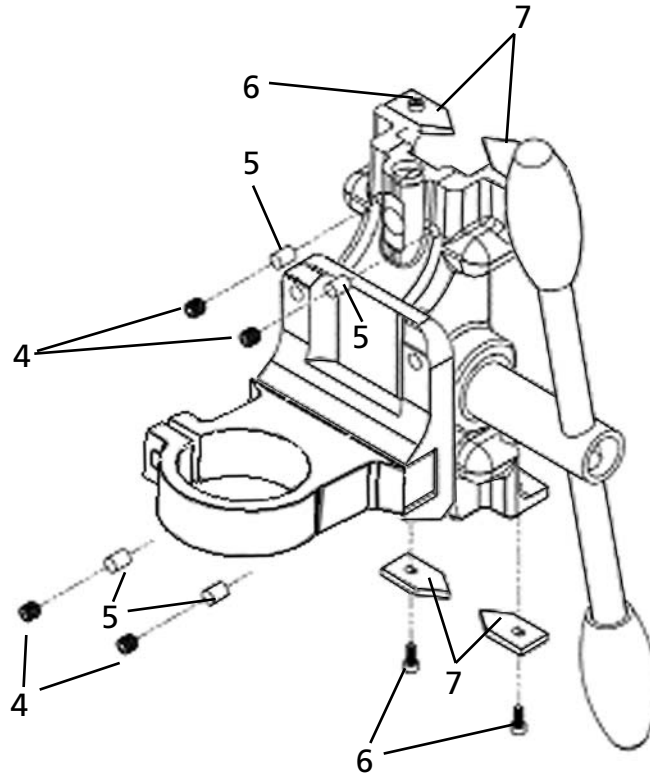

17. Spare Parts

Stocking Spare Parts

In order to gain maximum usage of your drill stand, it is necessary to ensure that an on-site stock of the most important spare parts and those parts subject to wear are always ready and on-hand.

The fitting and/or use of spare parts that we have not supplied or authorized may change the technical configuration of the drill stand; thus impairing active and/or passive operational safety. The manufacturer accepts no liability for damage due to the use of non-original spare parts.

Ordering Spare Parts

The following spare parts lists with diagrams are designed to assist you when ordering spare parts. When ordering spare parts, have the model number and part number ready.

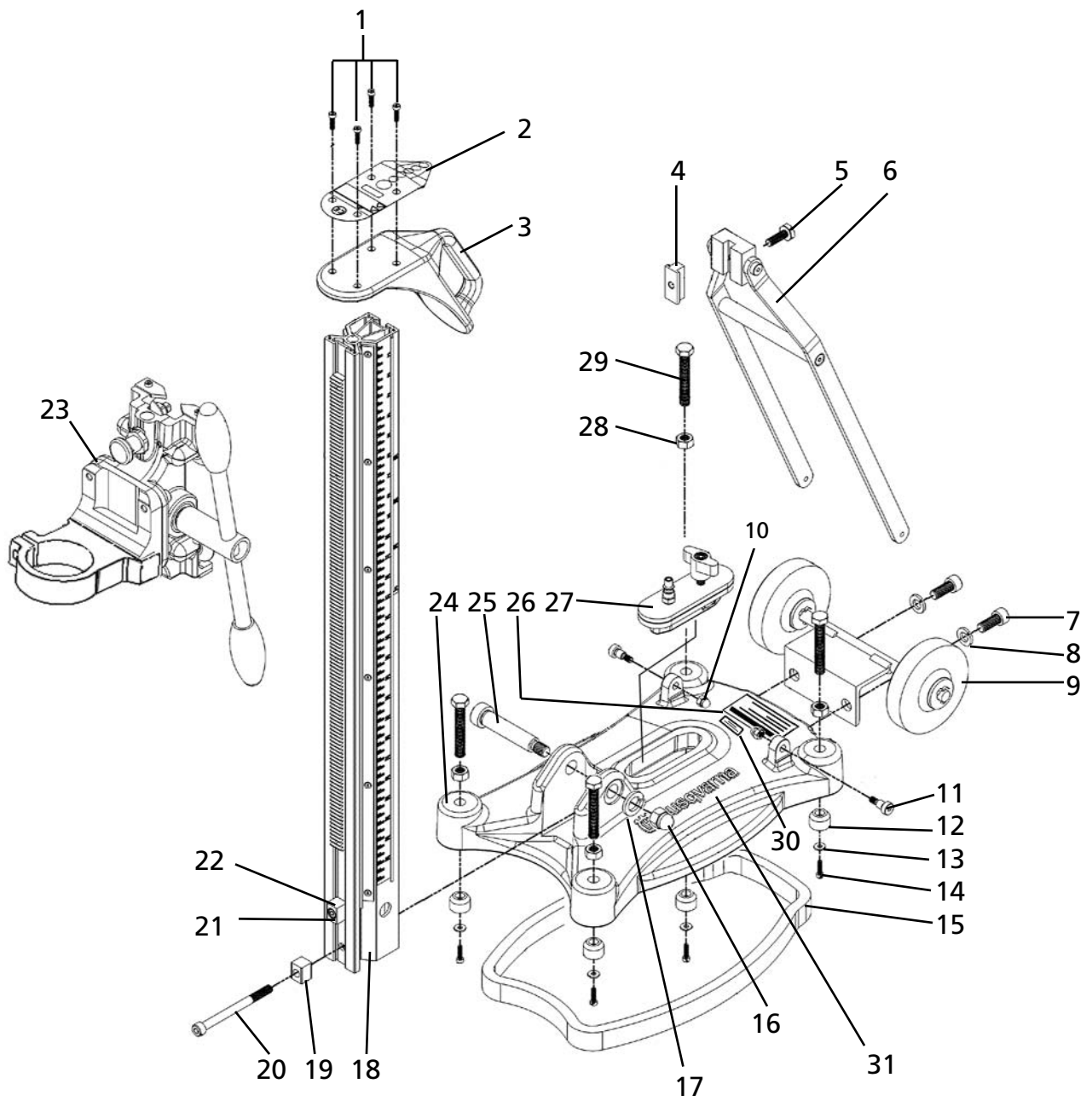

Drill Stand Parts

Item	Description	Part Number	Qty	Comments
1	M4x16 Socket Head Capscrew	541404147	4	
2	Handle Top Decal	541404097	1	
3	Column Handle	541404781	1	
4	T-Washer	541404078	1	
5	Angle Support Bolt	541404079	1	
6	Angle Support Assembly	541404109	1	Complete
7	M10x25 Socket Head Capscrew	541404155	2	
8	M10 Lockwasher	541404148	2	
9	Wheel Assembly	541404113	1	Complete
10	M6 Acorn Nut	541404141	2	
11	M8x10 Socket Head Shoulder Screw	541404139	2	
12	Leveling Screw Cap	541404084	4	
13	M4 Washer	541404146	4	
14	M4x16 Socket Head Capscrew	541404147	4	
15	Gasket	541404083	1	
16	M12 Acorn Nut	541404142	1	
17	M12 Lockwasher	541404143	1	
18	Drill Column Assembly	541404107	1	Complete
19	Column Spacer	541404081	1	
20	M8x90 Socket Head Capscrew	541404151	1	
21	M6x25 Socket Head Capscrew	541404136	1	
22	Carriage Stop	541404053	1	
23	Drill Carriage Assembly	541404782	1	Complete
24	Drill Base Casting	541404783	1	Complete
25	M16x70 Socket Head Shoulder Screw	541404144	1	
26	Drill Operating Instruction Decal	541404098	1	
27	Vacuum Cap Assembly	541404786	1	Complete
28	M10x1.5 Nut	541404145	4	
29	Leveling Screw	541404080	4	
30	Serial Number Decal	541404099	1	
31	Husqvarna Decal	542190734	1	
32	M6 Allen Wrench	541404153	1	Not Shown

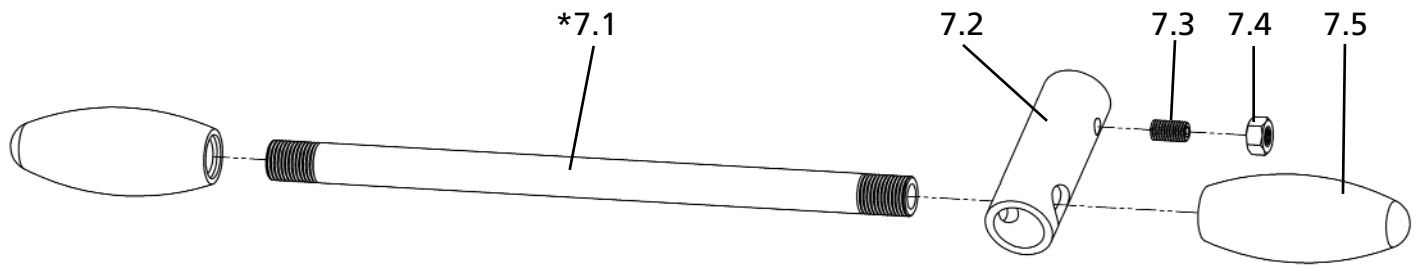
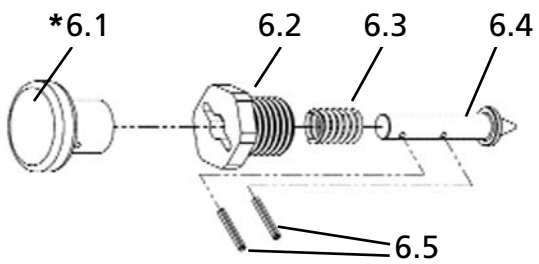
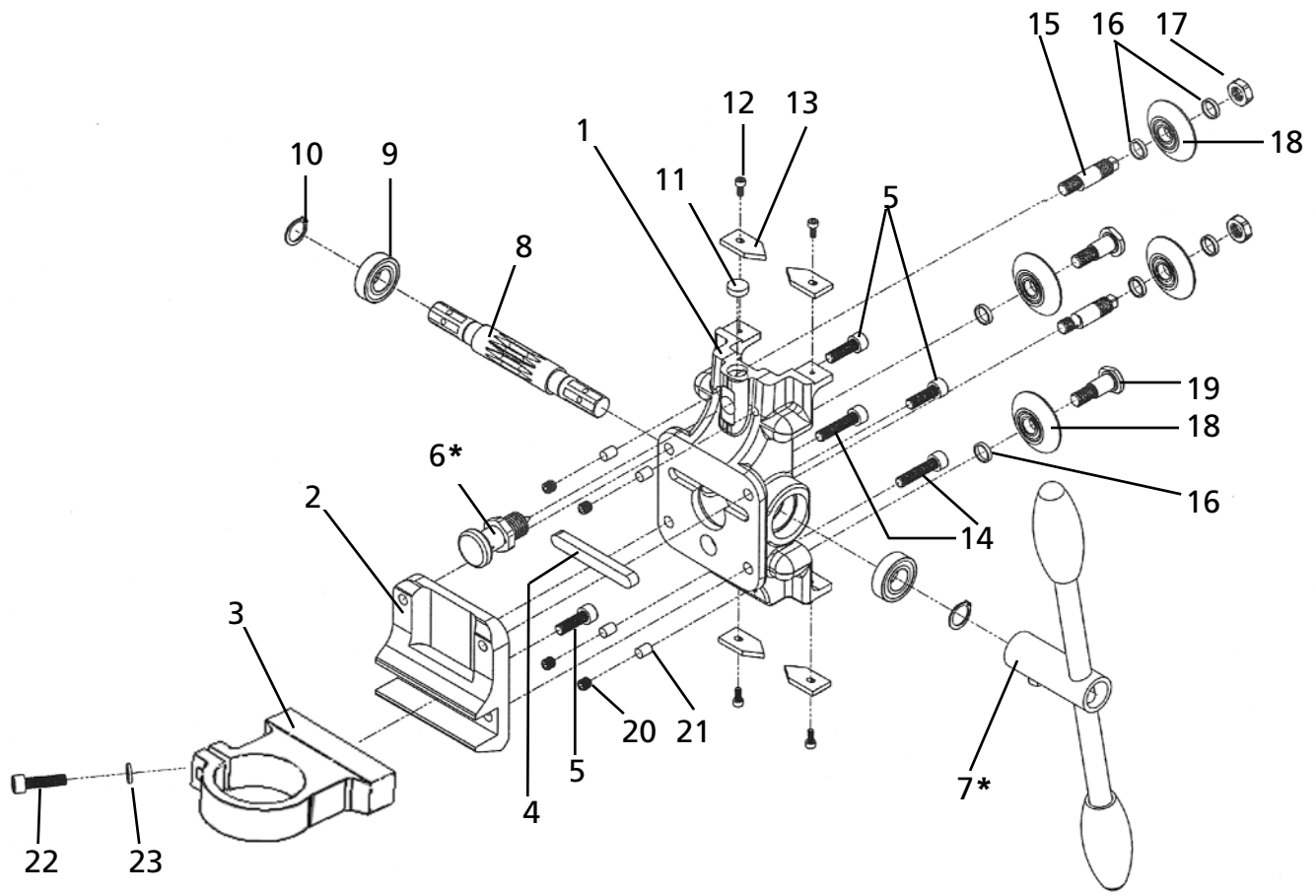

Item	Description	Part Number	Qty	Comments
1	Drill Carriage	541404784	1	
2	Adaptor Plate	541404029	1	
3	Drill Collar	541404030	1	
4	Key	541404031	1	
5	M8x25 Socket Head Capscrew	541404126	3	
6	Locking Mechanism	541404114	1	Complete
6.1	Knob	541404087	1	
6.2	Pin Retainer	541404085	1	
6.3	Compression Spring	541404089	1	
6.4	Pin	541404086	1	
6.5	Spring Pin 2mmx16mm	541404088	2	
7	Travel Lever Assembly	541404101	1	Complete
7.1	Travel Lever	541404043	1	
7.2	Travel Lever Drive Hub	541404044	1	
7.3	Stainless Steel Ball Plunger	541404133	1	
7.4	Hex Nut M8x1.25	541404132	1	
7.5	Travel Lever Knob	541404045	2	
8	Carriage Drive Shaft	541404040	1	
9	Bearing 17mmIDx35mmODx10mm Width	541404033	2	
10	External Retaining Ring	541404042	2	
11	Level Bubble	541404049	1	
12	M4x10 Socket Head Capscrew	541404130	4	
13	Side Cleaning Plate	541404035	4	
14	M8x35 Socket Head Capscrew	541404152	2	
15	Eccentric Shaft	541404039	2	
16	Spacer	541404036	6	
17	M12x1.75 Nut	541404131	2	
18	Roller Assembly	541404102	4	
19	Straight Shaft	541404038	2	
20	M8x8 Socket Set Screw-Cup Point	541404129	4	
21	Wear Cylinder	541404032	4	
22	M8x35 Socket Head Capscrew	541404152	1	
23	M8 Lock Nut	541404154	1	

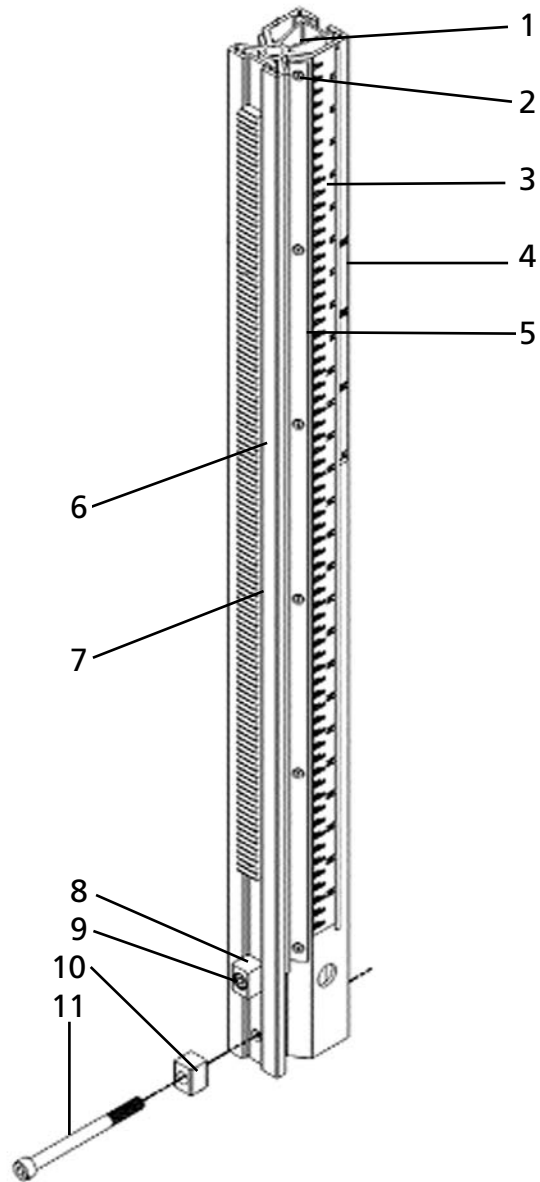

Item	Description	Part Number	Qty	Comments
1	Column	541404050	1	
2	M3x8 Socket Head, Flat Head Screw	541404137	24	
3	Depth Measurement Decal	541404054	2	
4	Angle Measurement Decal	541404055	2	
5	Wear Plate	541404052	4	
6	Rack	541404051	1	
7	M4x8 Socket Head Capscrew	541404135	6	
8	Carriage Stop	541404053	1	
9	M6x25 Socket Head Capscrew	541404136	1	
10	Column Spacer	541404081	1	
11	M8x90 Socket Head Capscrew	541404151	1	

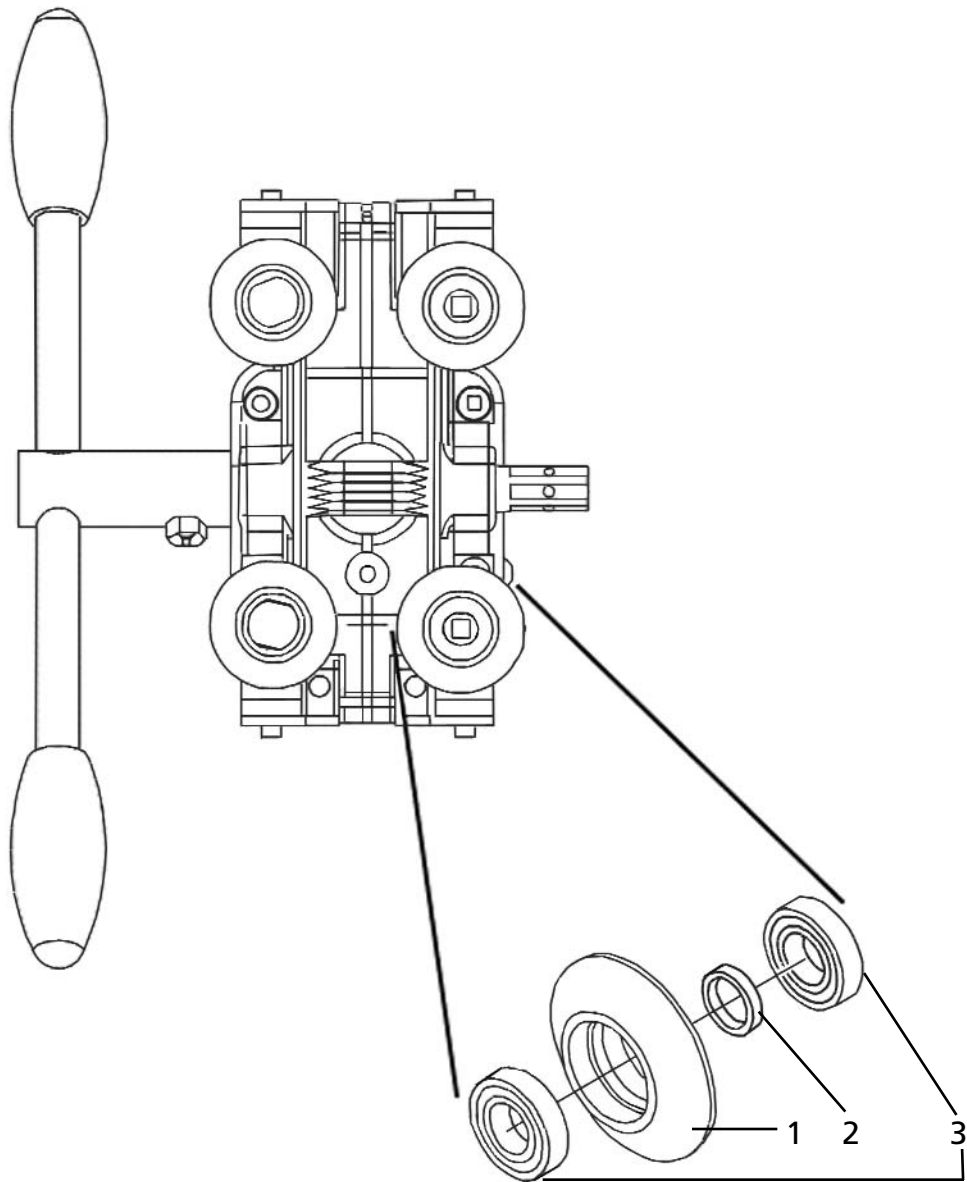

Item	Description	Part Number	Qty	Comments
1	Roller	541404037	1	
2	Spacer	541404036	1	
3	Bearing 12mmI.D.x24mmO.D.x6mm	541404034	2	

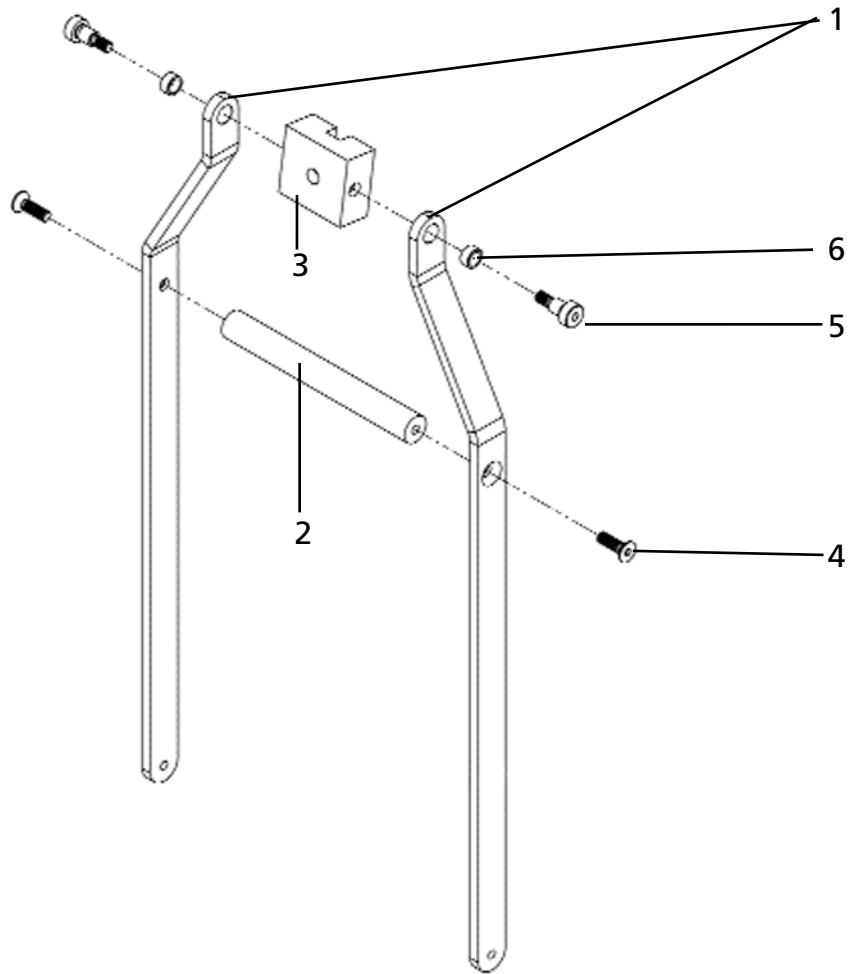

Item	Description	Part Number	Qty	Comments
1	Angle Support Member	541404062	2	
2	Angle Support Spacer	541404064	1	
3	T-Washer Retainer	541404065	1	
4	M6x20 Flat Socket Head Screw	541404138	2	
5	M8 Socket Head Shoulder Screw	541404139	2	
6	Angle Support Bushing	541404063	2	

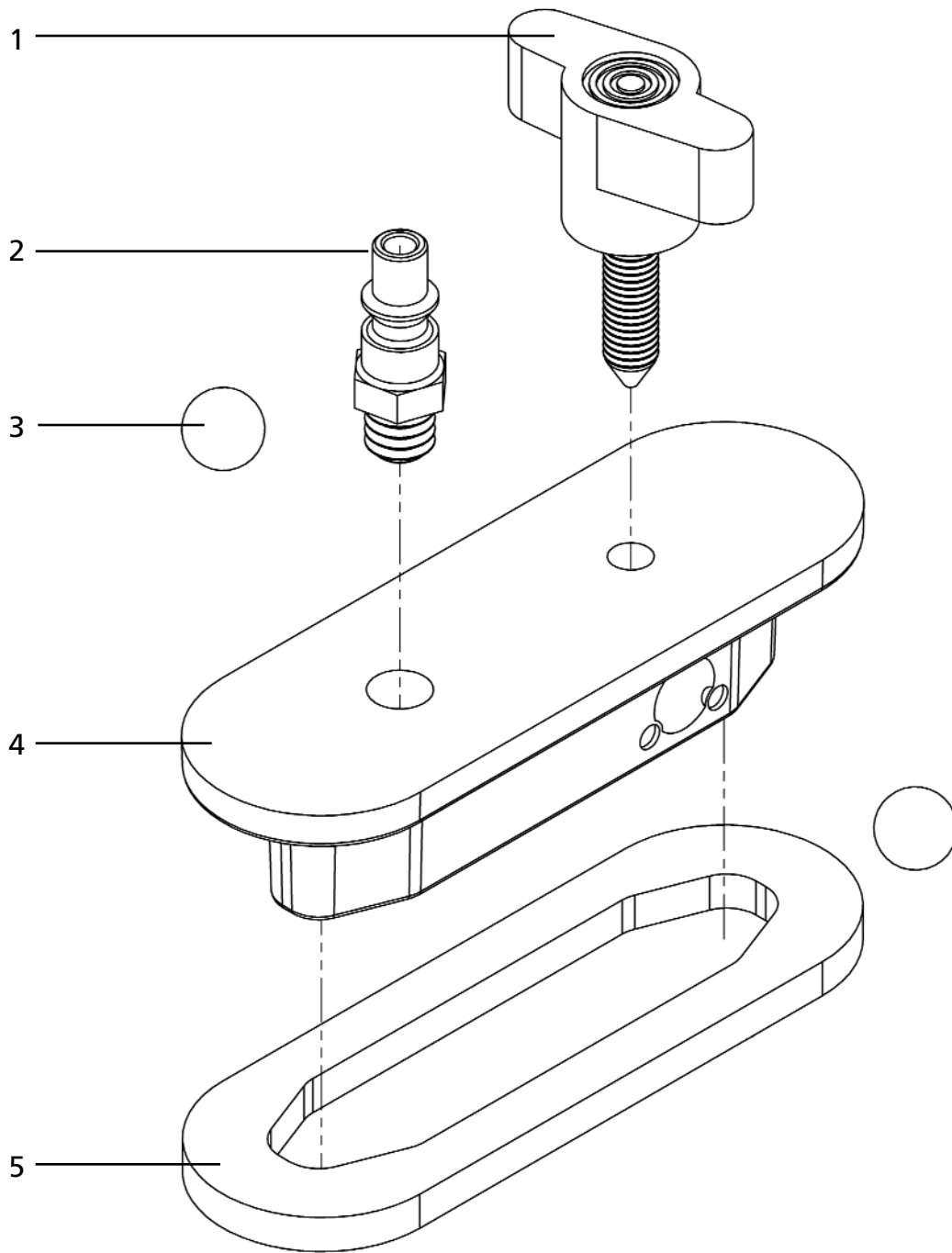

Item	Description	Part Number	Qty	Comments
1	Knob w/Stud	541404073	1	
2	1/8 NPT Male Fitting	541404071	1	
3	Ball Detent	541404072	2	
4	Vacuum Cap	541404785	1	
5	Vacuum Cap Gasket	541404070	1	

HUSQVARNA CONSTRUCTION PRODUCTS

Product Limited Warranty

Equipment manufactured by Husqvarna Construction Products is warranted to be free from defects in material and workmanship if operated properly, without abuse or negligence in normal service applications for a period of **two (2) years from date of purchase by the original consumer purchaser.**

Keep all payment records (bill of sale/delivery slip). The date on these records establishes the warranty period. Should warranty service be required, you must show proof of purchase. If proof of purchase cannot be supplied, the warranty period will be determined from the date of manufacture of the product.

All warranty claims will be determined after inspection at a designated facility. Write or call Husqvarna at 17400 W. 119th Street, Olathe, KS 66061, 800-365-5040, for instructions. The customer must prepay the freight and absorb any labor expense required to return or replace a product submitted to Husqvarna for warranty consideration. Husqvarna will pay return shipping expenses for repaired or approved replacement products. **Under no circumstances will Husqvarna be responsible for incidental or consequential damages.**

The responsibility of Husqvarna under this warranty is limited to the repair or replacement, at our option, of defective parts and assemblies at its plant in Olathe, KS and Torrance, CA and does not cover engines, motors, pumps, transmissions and other trade accessories sold with, attached to, or operated with Husqvarna products. Such components, parts and accessories are subject to the original manufacturer's warranty policy and procedures. Normal wear items, such as filters, V-belts and wheels are not covered under this warranty.

The Husqvarna warranty does not apply to defects caused by abuse, modifications, low voltage, acts of God, unreasonable use, faulty repairs made by others or damage or loss caused by failure to provide reasonable maintenance. All warranties are void if the equipment or any of its components are altered or modified by the purchaser, or if the product is used in a manner or with a blade not recommended by the manufacturer.

The foregoing express warranties are in lieu of all other warranties. **HUSQVARNA EXPRESSLY DISCLAIMS ALL OTHER WARRANTIES, INCLUDING, WITHOUT LIMITATION, THE IMPLIED WARRANTIES OF MERCHANTABILITY AND FITNESS FOR A PARTICULAR PURPOSE.**

Some states do not allow exclusion of warranties or limitations of damages, so the limitations and exclusions contained in this warranty may not apply to you. This warranty gives you specific legal rights. You may have additional rights, which vary from state to state.

Free Manuals Download Website

<http://myh66.com>

<http://usermanuals.us>

<http://www.somanuals.com>

<http://www.4manuals.cc>

<http://www.manual-lib.com>

<http://www.404manual.com>

<http://www.luxmanual.com>

<http://aubethermostatmanual.com>

Golf course search by state

<http://golfingnear.com>

Email search by domain

<http://emailbydomain.com>

Auto manuals search

<http://auto.somanuals.com>

TV manuals search

<http://tv.somanuals.com>