

# INSTALL INSTRUCTIONS P-MID-1 w/P-MFK-5 MIDDLE PARTITION w/MOUNTING FILLER PANEL KIT 1997-2008 CHEVROLET/GMC FULL SIZE PASSENGER VANS

## TOOLS REQUIRED:

Power drill  
Drill bit set

Ratcheting wrench  
Standard & Metric socket set

## HARDWARE:

<u>QTY</u>	<u>DESCRIPTION</u>	<u>PART #</u>
5	1/4" x 1 1/2" Hex head Lag Bolt	GSM33062
6	1/4" x 1" Hex head Lag Bolt	GSM33060
20	1/4-20 x 3/4" Carriage Bolt	GSM32000
12	1/4-20 Serrated Nut	GSM30023
8	1/4-20 Nylock Nut	GSM30016
1	5/16-18 Nylock Nut	GSM30017
1	5/16-18 x 2" Hex Head Bolt	GSM33015
2	5/16 Flat Washer	GSM31006
8	1/4" x 1" Fender Washer	GSM31014

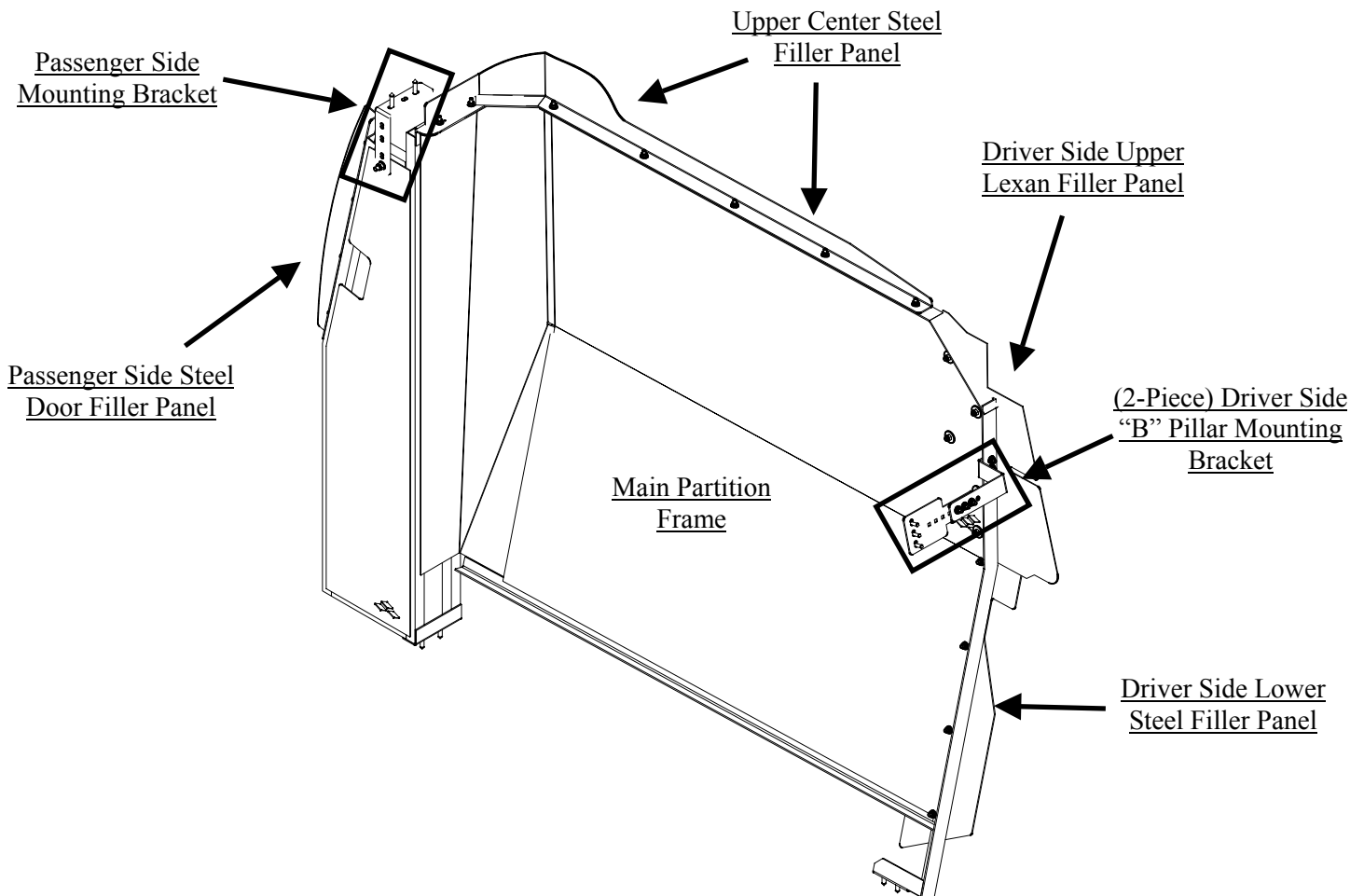

## SUB ASSEMBLY:

1. Remove "C" pillar trim panel. This is necessary for driver side mounting bracket.
2. Position upper center filler to partition and mark mounting holes.
3. Drill 5/16" holes on marks.

### Always!

- Read all instructions before installing any Havis-Shields Equipment Corp products.
- Check for obstructions (Wire, brake lines, fuel tank, etc.) before drilling any holes!
- Use hardware provided with install kit

## INSTALLATION:

### 1. ATTACH PARTITION TO FLOOR:

- Place partition carefully into vehicle behind the first row bench.
- Move bottom of partition forward to the back of seat base on first row bench.

*Note: Driver side mounting leg on partition will be forward of seat belt hold down on floor of van.*

- Pre-drill the (3) driver side mounting leg holes with 3/16" drill bit. Be sure to check for obstructions.
- Attach partition to van floor at driver side mounting leg using (3) 1/4" x 1 1/2" Hex head lag bolts.
- Proceed to partitions passenger side mounting leg. Be sure to check that partition is square with the bench seat.
- Pre-drill the (2) passenger side mounting leg holes with 3/16" drill bit. Be sure to check for obstructions.
- Attach partition to van floor at passenger side mounting leg using (2) 1/4" x 1 1/2" Hex head lag bolts. Partition is now self-supporting.



1/4" x 1 1/2" Hex Head Lag Bolts

### 2. ATTACH (2- PIECE) DRIVER SIDE "B" PILLAR MOUNTING BRACKET:

- Hold 2-piece driver side mounting bracket to partition and "C-pillar" of van.
- Determine proper location to mount 2-piece bracket to partition.
- Drill (2) 5/16" holes where mounting bracket and partition meet.
- Attach bracket to partition using 1/4-20 x 3/4" Carriage bolts and

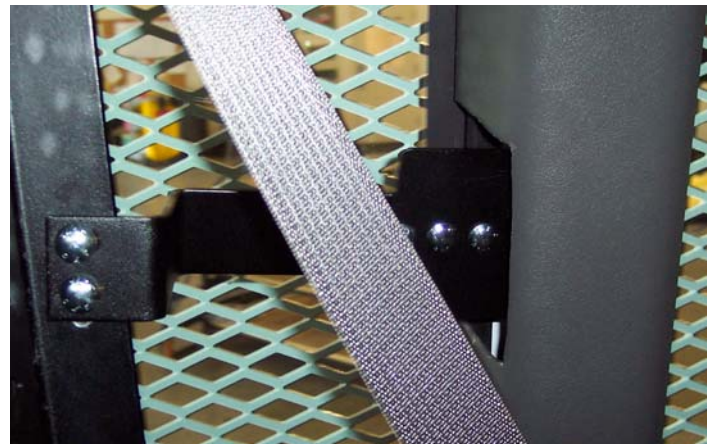

serrated nuts.

- Press partition as far forward and mark mounting holes where driver side mounting bracket and “C-pillar” come in contact.
- Pre-drill 3/16” holes into “C-pillar”.
- Attach bracket to C-pillar using (3) 1/4” x 1” Hex head lag bolts.
- Plastic trim panel must be notched around bracket to mount.

### 3. ATTACH PASSENGER SIDE MOUNTING BRACKET:

- Press partition as far forward as possible and holding bracket to partition (square tubing section) determine where to slot headliner to accept mounting bracket.
- Slot headliner and position mounting bracket to be flush with vehicle inner roof support.
- Mark (3) mounting holes and pre-drill using 3/16” drill bit.
- Attach bracket to vehicle using (3) 1/4” x 1” Hex head lag bolts.
- Press partition up to bracket and mark holes where bracket and partition come together.
- Drill 5/16” holes on these marks and bolt partition to bracket using 5/16-18 x 2” Hex head bolt, washer, and nylock nut.

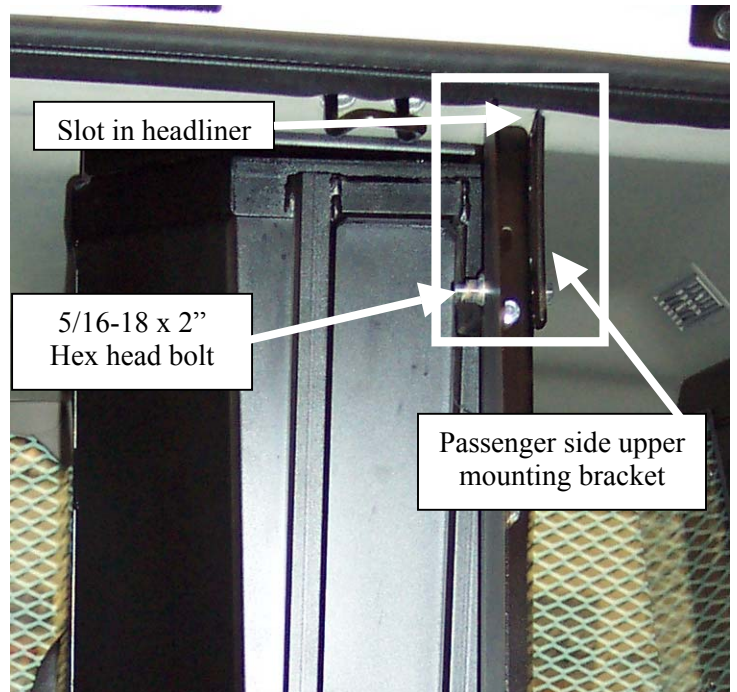

### 4. ATTACH UPPER STEEL CENTER FILLER PANEL:

- Attach upper center filler to partition through the holes pre-drilled at subassembly using 1/4-20 x 3/4” Carriage bolts and serrated nuts.
- Tighten all hardware.

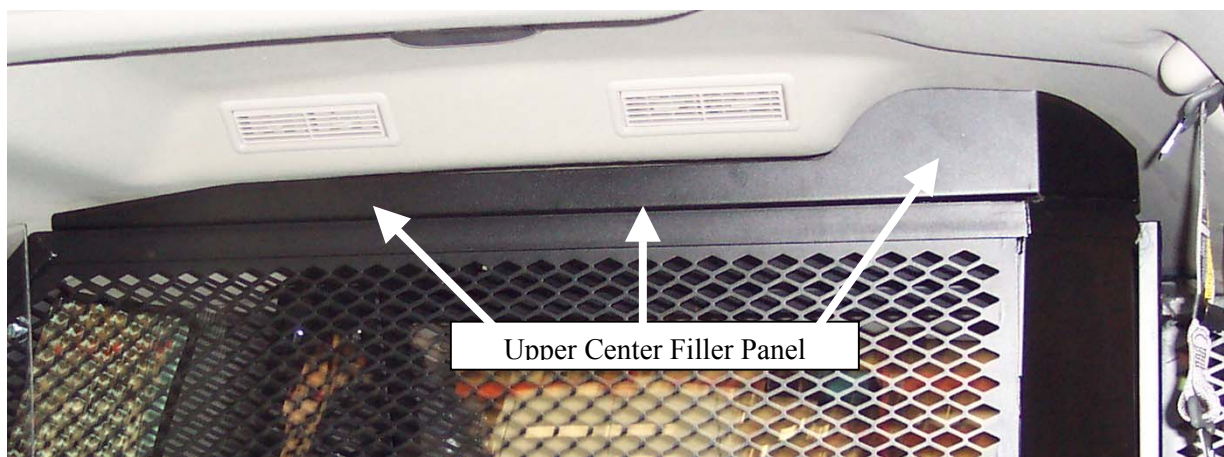



## 5. ATTACH DRIVER SIDE UPPER LEXAN FILLER PANEL:

- Position driver side  $\frac{1}{4}$ " lexan filler panel to partition so that minimal space is between the vehicles window, (or window guard) and the lexan filler.

**NOTE:** It is necessary to keep a  $\frac{1}{8}$ " gap between the window or guard and the filler to allow for expansion and contraction of the lexan during temperature fluctuations.

- Drill (6)  $\frac{5}{16}$ " holes evenly spaced through both the  $\frac{1}{4}$ " lexan filler panel and the partition frame. Attaching to the frame directly will help to avoid filler rattling.
- Bolt lexan filler to partition using  $\frac{1}{4}$ -20 x  $\frac{3}{4}$ " carriage bolts and nylock nuts.

## 6. ATTACH DRIVER SIDE LOWER STEEL FILLER PANEL:

- Position driver side lower aluminum filler panel tight to vehicles interior trim and floor.
- Using slots in filler panel as a drill guide mark and drill partition using  $\frac{5}{16}$ " drill bit.
- Attach filler panel to partition using  $\frac{1}{4}$ -20 x  $\frac{3}{4}$ " carriage bolts and serrated nuts.

## 7. ATTACH PASSENGER SIDE DOOR STEEL FILLER PANEL:

- Position on front row bench in van close side doors.
- Hold filler panel to partition so that it does not interfere door mechanisms.
- Mark and drill  $\frac{3}{16}$ " holes through partition tubing.
- Attach filler to partition using  $\frac{1}{4}$ -20 x  $\frac{3}{4}$ " Hex head thread cutting bolts.
- Vacuum out all metal shaving and double check door operation.

Driver side upper lexan filler

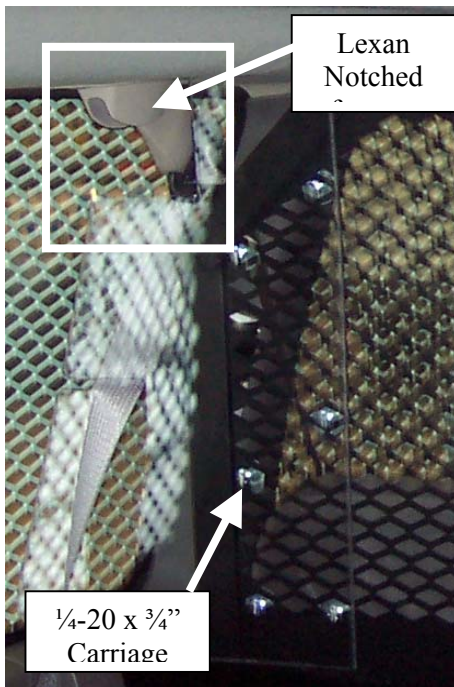

Passenger Side Inner Steel Filler Panel

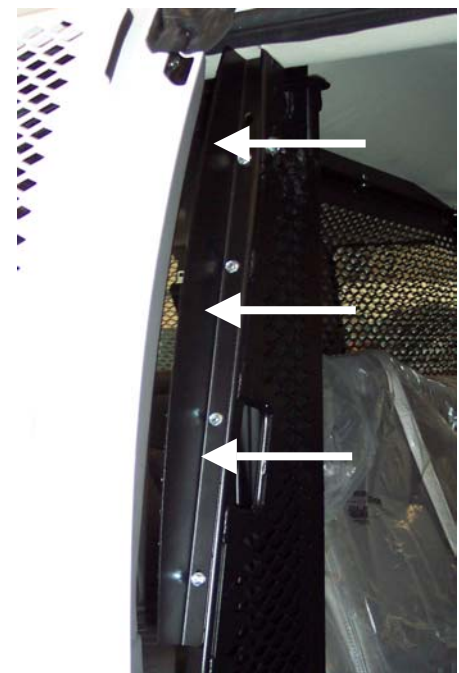

## Free Manuals Download Website

<http://myh66.com>

<http://usermanuals.us>

<http://www.somanuals.com>

<http://www.4manuals.cc>

<http://www.manual-lib.com>

<http://www.404manual.com>

<http://www.luxmanual.com>

<http://aubethermostatmanual.com>

Golf course search by state

<http://golfingnear.com>

Email search by domain

<http://emailbydomain.com>

Auto manuals search

<http://auto.somanuals.com>

TV manuals search

<http://tv.somanuals.com>