

# GA-VM800PMC

Intel® Core™ 2 Duo / Intel® Pentium® D / Pentium® 4 / Celeron® D  
LGA775 Processor Motherboard

## User's Manual

Rev. 1003

12ME-VM800PMC-1003R



\* The WEEE marking on the product indicates this product must not be disposed of with user's other household waste and must be handed over to a designated collection point for the recycling of waste electrical and electronic equipment!!

\* The WEEE marking applies only in European Union's member states.

## Declaration of Conformity

We, Manufacturer/Importer  
(full address)

G.B.T. Technology, Inc.  
17358 Railroad Street  
City of Industry, CA 91748, Germany

(description of the apparatus, system, installation to which it refers)  
(declare that the product)

**Motherboard**

GA-VM800PMC

(reference to the specification under which conformity is declared)  
is in conformity with  
in accordance with 91/263 EEC-EMC Directive

- |   |   |  |   |
|---|---|--|---|
| <input type="checkbox"/> EN 55011             | Units and methods of measurement of radio disturbance characteristics of industrial, scientific and medical (ISM) high frequency equipment                | <input checked="" type="checkbox"/> EN 61000-3-2 | Disturbances in supply systems caused by household appliances and similar electrical equipment "Voltage fluctuations" |
| <input type="checkbox"/> EN 55013             | Units and methods of measurement of radio disturbance characteristics of electronic receivers and associated equipment                                    | <input checked="" type="checkbox"/> EN 55024     | Information Technology equipment/immunity   |
| <input type="checkbox"/> EN 55014-1           | Units and methods of measurement of radio disturbance characteristics of household electrical appliances, portable tools and similar electrical apparatus | <input type="checkbox"/> EN 55022-1              | Generic immunity standard Part 1: Residential, commercial and light industry  |
| <input type="checkbox"/> EN 55015             | Units and methods of measurement of radio disturbance characteristics of television, lamps and luminaires   | <input type="checkbox"/> EN 55022-2              | Industrial environment  |
| <input type="checkbox"/> EN 55020             | Immunity from radio interference of broadcast receivers and associated equipment  | <input type="checkbox"/> EN 55014-2              | Immunity requirements for household appliances, tools and similar apparatus   |
| <input checked="" type="checkbox"/> EN 55022  | Units and methods of measurement of radio disturbance characteristics of information technology equipment   | <input type="checkbox"/> EN 55019-1-2            | EMC requirements for uninteruptible power systems (UPS)   |
| <input type="checkbox"/> DIN VDE 0855 Part 12 | Cabled distribution systems, Equipment for data processing, from sound and television signals   |  |   |

CE marking



(EC conformity marking)

The manufacturer also declares the conformity of above mentioned product with the safety required safety standards in accordance with LVD 73/23 EEC

- |                                   |  |                                     |   |
|-----------------------------------|--|-------------------------------------|---|
| <input type="checkbox"/> EN 60065 | Safety requirements for mains operated household and similar general use electrical appliances | <input type="checkbox"/> EN 60950   | Safety for information technology equipment including electrical business equipment |
| <input type="checkbox"/> EN 60335 | Safety of household and similar electrical appliances  | <input type="checkbox"/> EN 60971-1 | General and Safety requirements for uninteruptible power systems (UPS)              |

Manufacturer/Importer

Signature : *Jimmy Huang*

(Stamp)

Date : Dec. 5, 2006

Name : Timmy Huang

## DECLARATION OF CONFORMITY

Per FCC Part 2, Section 2.1077(a)



Responsible Party Name: G.B.T. INC. (U.S.A.)

Address: 17358 Railroad Street

City of Industry, CA 91748

Phone/Fax No: (818) 854-9338 / (818) 854-9339

hereby declares that the product

Product Name: **Motherboard**

Model Number: **GA-VM800PMC**

Conforms to the following specifications:

FCC Part 15, Subpart B, Section 15.107(a) and Section 15.109

(a), Class B Digital Device

**Supplementary Information:**

This device complies with part 15 of the FCC Rules. Operation is subject to the following two conditions: (1) This device may not cause harmful and (2) this device must accept any interference received, including that may cause undesired operation.

Representative Person's Name: ERIC LU

Signature: *Eric Lu*

Date: Dec. 5, 2006

## Copyright

© 2006 GIGA-BYTE TECHNOLOGY CO., LTD. All rights reserved.

The trademarks mentioned in the manual are legally registered to their respective companies.

## Notice

The written content provided with this product is the property of Gigabyte.

No part of this manual may be reproduced, copied, translated, or transmitted in any form or by any means without Gigabyte's prior written permission. Specifications and features are subject to change without prior notice.

## Product Manual Classification

In order to assist in the use of this product, Gigabyte has categorized the user manual in the following:

- For detailed product information and specifications, please carefully read the "Product User Manual".
  
- For detailed information related to Gigabyte's unique features, please go to "Technology Guide" section on Gigabyte's website to read or download the information you need.

For more product details, please click onto Gigabyte's website at [www.gigabyte.com.tw](http://www.gigabyte.com.tw)

# Table of Contents

Item Checklist .....	6
Optional Accessories .....	6
GA-VM800PMC Motherboard Layout .....	7
Block Diagram .....	8
Chapter 1 Hardware Installation .....	9
1-1 Considerations Prior to Installation .....	9
1-2 Feature Summary .....	10
1-3 Installation of the CPU and CPU Cooler .....	12
1-3-1 Installation of the CPU .....	12
1-3-2 Installation of the CPU Cooler .....	13
1-4 Installation of Memory .....	14
1-5 Installation of Expansion Cards .....	15
1-6 I/O Back Panel Introduction .....	16
1-7 Connectors Introduction .....	17
Chapter 2 BIOS Setup .....	27
The Main Menu (For example: BIOS Ver. : D5) .....	28
2-1 Standard CMOS Features .....	30
2-2 Advanced BIOS Features .....	32
2-3 Integrated Peripherals .....	34
2-4 Power Management Setup .....	36
2-5 PnP/PCI Configurations .....	38
2-6 PC Health Status .....	39
2-7 Load Fail-Safe Defaults .....	41
2-8 Load Optimized Defaults .....	41
2-9 Set Supervisor/User Password .....	42
2-10 Save & Exit Setup .....	43
2-11 Exit Without Saving .....	43

Chapter 3 Drivers Installation .....	45
3-1 Install Chipset Drivers .....	45
3-2 Software Application .....	46
3-3 Software Information .....	46
3-4 Hardware Information .....	47
3-5 Contact Us .....	47
 Chapter 4 Appendix .....	 49
4-1 Unique Software Utilities .....	49
4-1-1 EasyTune 5 Introduction .....	49
4-1-2 Xpress Recovery2 Introduction .....	50
4-1-3 Flash BIOS Method Introduction .....	52
4-1-4 Configuring SATA Hard Drive(s) .....	61
4-1-5 2 / 4 / 6 Channel Audio Function Introduction .....	73
4-2 Troubleshooting .....	78

## Item Checklist

- IDE Cable x 1, FDD Cable x 1
- SATA Cable x 1
- I/O Shield

\* The items listed above are for reference only, and are subject to change without notice.

---

## Optional Accessories

- ◆ 2 Ports USB 2.0 Cable (Part Number: 12CR1-1UB030-51/R)
- ◆ 4 Ports USB 2.0 Cable (Part Number: 12CR1-1UB030-21/R)
- ◆ 6-Channel Audio Combo Kit (Part Number: 12CR1-1SPAUD-12)
- ◆ S/PDIF In and Out Cable (Part Number: 12CR1-1SPINO-11/R)
- ◆ COM Port Cable (Part Number: 12CF1-1CM001-31/12CF1-1CM001-12R)

# GA-VM800PMC Motherboard Layout

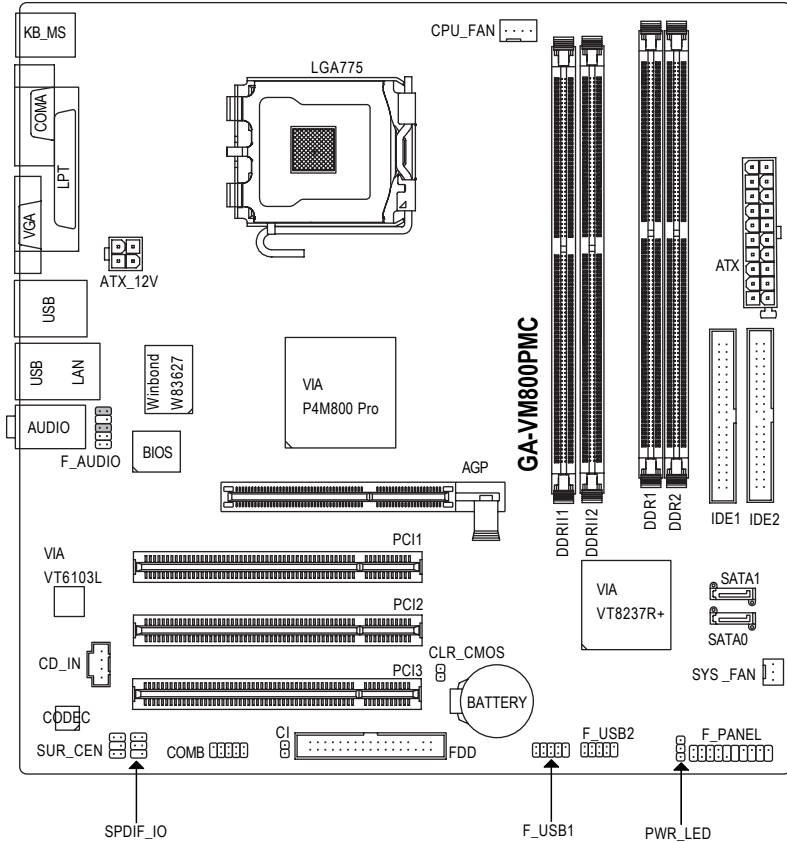

# Block Diagram

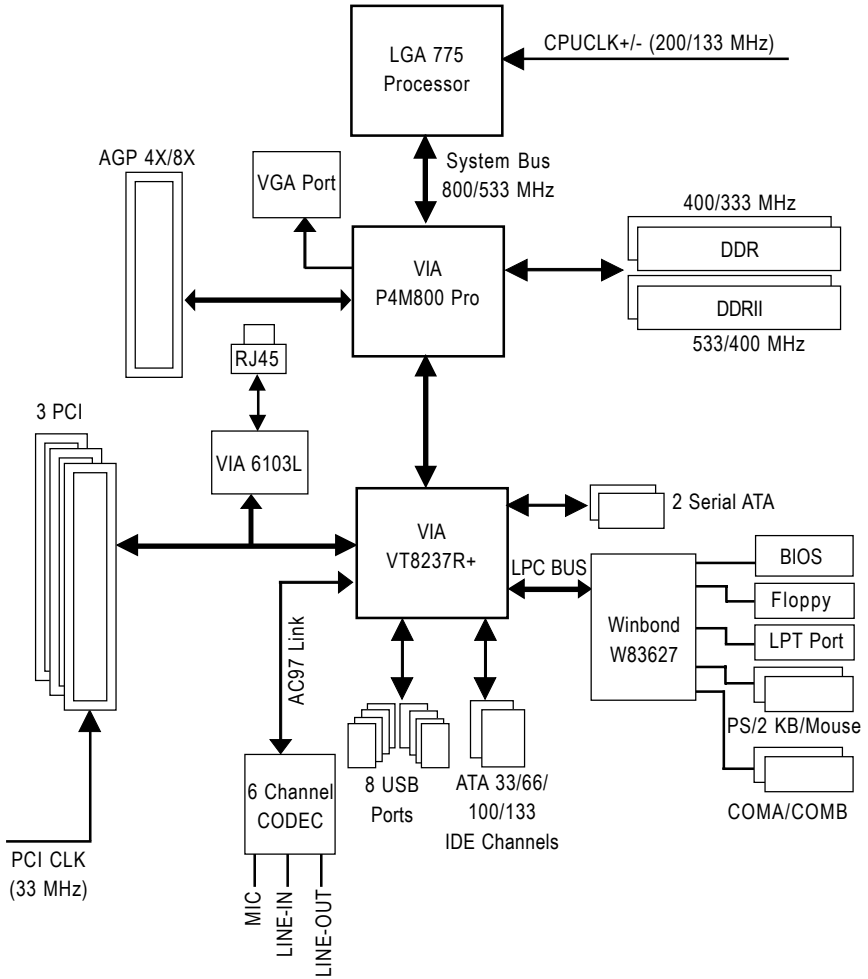



# Chapter 1 Hardware Installation

## 1-1 Considerations Prior to Installation

### Preparing Your Computer

The motherboard contains numerous delicate electronic circuits and components which can become damaged as a result of electrostatic discharge (ESD). Thus, prior to installation, please follow the instructions below:

1. Please turn off the computer and unplug its power cord.
2. When handling the motherboard, avoid touching any metal leads or connectors.
3. It is best to wear an electrostatic discharge (ESD) cuff when handling electronic components (CPU, RAM).
4. Prior to installing the electronic components, please have these items on top of an antistatic pad or within a electrostatic shielding container.
5. Please verify that the power supply is switched off before unplugging the power supply connector from the motherboard.

### Installation Notices

1. Prior to installation, please do not remove the stickers on the motherboard. These stickers are required for warranty validation.
2. Prior to the installation of the motherboard or any hardware, please first carefully read the information in the provided manual.
3. Before using the product, please verify that all cables and power connectors are connected.
4. To prevent damage to the motherboard, please do not allow screws to come in contact with the motherboard circuit or its components.
5. Please make sure there are no leftover screws or metal components placed on the motherboard or within the computer casing.
6. Please do not place the computer system on an uneven surface.
7. Turning on the computer power during the installation process can lead to damage to system components as well as physical harm to the user.
8. If you are uncertain about any installation steps or have a problem related to the use of the product, please consult a certified computer technician.

### Instances of Non-Warranty

1. Damage due to natural disaster, accident or human cause.
2. Damage as a result of violating the conditions recommended in the user manual.
3. Damage due to improper installation.
4. Damage due to use of uncertified components.
5. Damage due to use exceeding the permitted parameters.
6. Product determined to be an unofficial Gigabyte product.

## 1-2 Feature Summary

CPU	<ul style="list-style-type: none"> <li>◆ Supports LGA775 Intel® Core™ 2 Duo<sup>(Note 1)</sup> / Pentium® D / Pentium® 4 / Celeron® D</li> <li>◆ L2 cache varies with CPU</li> </ul>
Front Side Bus	◆ Supports 800/533 MHz FSB
Chipset	<ul style="list-style-type: none"> <li>◆ Northbridge: VIA P4M800 Pro Chipset</li> <li>◆ Southbridge: VIA VT8237R+</li> </ul>
LAN	◆ Onboard VIA 6103L chip (10/100 Mbit)
Audio	<ul style="list-style-type: none"> <li>◆ Onboard VIA 1618 chip</li> <li>◆ Supports 2 / 4 / 6 channel audio</li> <li>◆ Supports S/PDIF In/Out connection</li> <li>◆ Supports CD In connection</li> </ul>
Storage	<ul style="list-style-type: none"> <li>◆ VT8237R+ Southbridge               <ul style="list-style-type: none"> <li>- 1 FDD connector, allowing connection of 1 FDD device</li> <li>- 2 IDE connectors with UDMA 33/ATA 66/ATA 100/ATA 133 support, allowing connection of 4 IDE devices</li> <li>- 2 SATA connectors, allowing connection of 2 SATA devices</li> <li>- Supports data striping (RAID 0), mirroring (RAID 1) for Serial ATA</li> </ul> </li> </ul>
O.S Support	◆ Microsoft Windows 2000/XP
Memory	<ul style="list-style-type: none"> <li>◆ DDRII               <ul style="list-style-type: none"> <li>- 2 DDRII DIMM memory slots (supports up to 2GB memory)</li> <li>- Supports DDRII 533/400 unbuffered DIMMs</li> <li>- Supports 1.8V DDRII DIMMs</li> </ul> </li> <li>◆ DDR               <ul style="list-style-type: none"> <li>- 2 DDR DIMM memory slots (supports up to 2GB memory)</li> <li>- Supports DDR 400/333 unbuffered DIMMs</li> <li>- Supports 2.5V DDR DIMMs</li> </ul> </li> </ul> <p>(Note: Mixed mode, populating DDR and DDRII memory modules simultaneously is not supported. To avoid memory incompatibility, do use the memory modules on the memory support list at GIGABYTE's website.)</p>
Expansion Slots	<ul style="list-style-type: none"> <li>◆ 1 AGP slot</li> <li>◆ 3 PCI slots</li> </ul>
Internal Connectors	<ul style="list-style-type: none"> <li>◆ 1 20-pin ATX power connector</li> <li>◆ 1 4-pin ATX 12V power connector</li> <li>◆ 1 floppy connector</li> <li>◆ 2 IDE connectors</li> <li>◆ 2 SATA connectors</li> <li>◆ 1 CPU fan connector</li> <li>◆ 1 system fan connector</li> <li>◆ 1 front panel connector</li> <li>◆ 1 front audio connector</li> <li>◆ 1 CD In connector</li> <li>◆ 1 S/PDIF In/Out connector</li> <li>◆ 1 SUR_CEN connector</li> <li>◆ 1 COMB connector</li> </ul>

Internal Connectors	<ul style="list-style-type: none"> <li>◆ 2 USB 2.0/1.1 connectors for additional 4 USB 2.0/1.1 ports by cables</li> <li>◆ 1 Chassis Intrusion connector</li> <li>◆ 1 power LED connector</li> </ul>
Rear Panel I/O	<ul style="list-style-type: none"> <li>◆ 1 PS/2 keyboard port</li> <li>◆ 1 PS/2 mouse port</li> <li>◆ 1 parallel port</li> <li>◆ 1 serial port</li> <li>◆ 1 VGA port</li> <li>◆ 4 USB 2.0/1.1 ports</li> <li>◆ 1 RJ-45 port</li> <li>◆ 3 audio jacks (Line In / Line Out / MIC In)</li> </ul>
I/O Control	<ul style="list-style-type: none"> <li>◆ Winbond W83627 chip</li> </ul>
Hardware Monitor	<ul style="list-style-type: none"> <li>◆ System voltage detection</li> <li>◆ System / CPU temperature detection</li> <li>◆ System / CPU fan speed detection</li> <li>◆ System / CPU warning temperature</li> <li>◆ System / CPU fan failure warning</li> <li>◆ CPU smart fan control</li> </ul>
BIOS	<ul style="list-style-type: none"> <li>◆ 1 4 Mbit flash ROM</li> <li>◆ Use of licensed AWARD BIOS</li> </ul>
Additional Features	<ul style="list-style-type: none"> <li>◆ Supports @BIOS</li> <li>◆ Supports Download Center</li> <li>◆ Supports Q-Flash</li> <li>◆ Supports EasyTune (only supports Hardware Monitor function) <sup>(Note 2)</sup></li> <li>◆ Supports Xpress Install</li> <li>◆ Supports Xpress Recovery2</li> <li>◆ Supports Xpress BIOS Rescue</li> </ul>
Bundle Software	<ul style="list-style-type: none"> <li>◆ Norton Internet Security (OEM version)</li> </ul>
Form Factor	<ul style="list-style-type: none"> <li>◆ Micro ATX form factor; 24.4cm x 24.4cm</li> </ul>

(Note 1) Based on chipset specifications, the GA-VM800PMC can support up to 800 MHz FSB.

(Note 2) EasyTune functions may vary depending on different motherboards.

## 1-3 Installation of the CPU and CPU Cooler



Before installing the CPU, please comply with the following conditions:

1. Please make sure that the motherboard supports the CPU.
2. Please take note of the one indented corner of the CPU. If you install the CPU in the wrong direction, the CPU will not insert properly. If this occurs, please change the insert direction of the CPU.
3. Please add an even layer of heat sink paste between the CPU and heatsink.
4. Please make sure the heatsink is installed on the CPU prior to system use, otherwise overheating and permanent damage of the CPU may occur.
5. Please set the CPU host frequency in accordance with the processor specifications. It is not recommended that the system bus frequency be set beyond hardware specifications since it does not meet the required standards for the peripherals. If you wish to set the frequency beyond the proper specifications, please do so according to your hardware specifications including the CPU, graphics card, memory, hard drive, etc.



### HT functionality requirement content :

Enabling the functionality of Hyper-Threading Technology for your computer system requires all of the following platform components:

- CPU: An Intel® Pentium 4 Processor with HT Technology
- Chipset: An Intel® Chipset that supports HT Technology
- BIOS: A BIOS that supports HT Technology and has it enabled
- OS: An operation system that has optimizations for HT Technology

### 1-3-1 Installation of the CPU

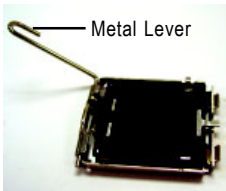

Fig. 1  
Gently lift the metal lever located on the CPU socket to the upright position.

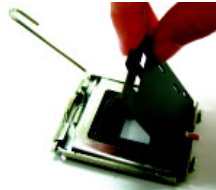

Fig. 2  
Remove the plastic covering on the CPU socket.

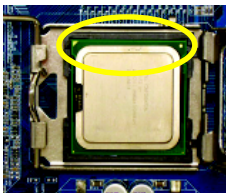

Fig. 3  
Notice the small gold colored triangle located on the edge of the CPU socket. Align the indented corner of the CPU with



Fig. 4  
Once the CPU is properly inserted, please replace the plastic covering and push the metal lever back into its original position.

the triangle and gently insert the CPU into position. (Grasping the CPU firmly between your thumb and forefinger, carefully place it into the socket in a straight and downwards motion. Avoid twisting or bending motions that might cause damage to the CPU during installation.)

### 1-3-2 Installation of the CPU Cooler



Fig. 1  
Please apply an even layer of CPU cooler paste on the surface of the installed CPU.

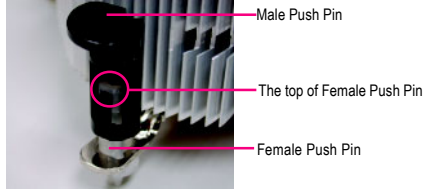

Fig. 2  
(Turning the push pin along the direction of arrow is to remove the CPU cooler, on the contrary, is to install.) Please note the direction of arrow sign on the male push pin doesn't face inwards before installation. (This instruction is only for Intel boxed fan)

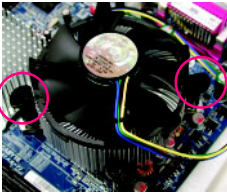

Fig. 3  
Place the CPU cooler atop the CPU and make sure the push pins aim to the pin hole on the motherboard. Pressing down the push pins diagonally.

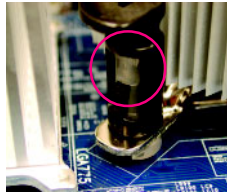

Fig. 4  
Please make sure the Male and Female push pin are joined closely. (for detailed installation instructions, please refer to the CPU cooler installation section of the user manual)

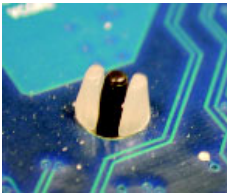

Fig. 5  
Please check the back of motherboard after installing. If the push pin is inserted as the picture, the installation is complete.

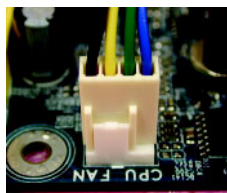

Fig. 6  
Finally, please attach the power connector of the CPU cooler to the CPU fan header located on the motherboard.



The CPU cooler may adhere to the CPU as a result of hardening of the heat paste. To prevent such an occurrence, it is suggested that either thermal tape rather than heat paste be used for heat dissipation or using extreme care when removing the CPU cooler.

## 1-4 Installation of Memory



Before installing the memory modules, please comply with the following conditions:

1. Please make sure that the memory used is supported by the motherboard. It is recommended that memory of similar capacity, specifications and brand be used.
2. Before installing or removing memory modules, please make sure that the computer power is switched off to prevent hardware damage.
3. Memory modules have a foolproof insertion design. A memory module can be installed in only one direction. If you are unable to insert the module, please switch the direction.

The motherboard supports DDRII/DDR memory modules, whereby BIOS will automatically detect memory capacity and specifications. Memory modules are designed so that they can be inserted only in one direction. The memory capacity used can differ with each slot.

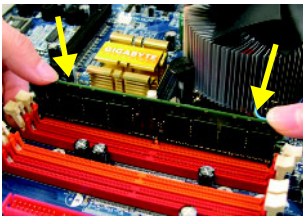
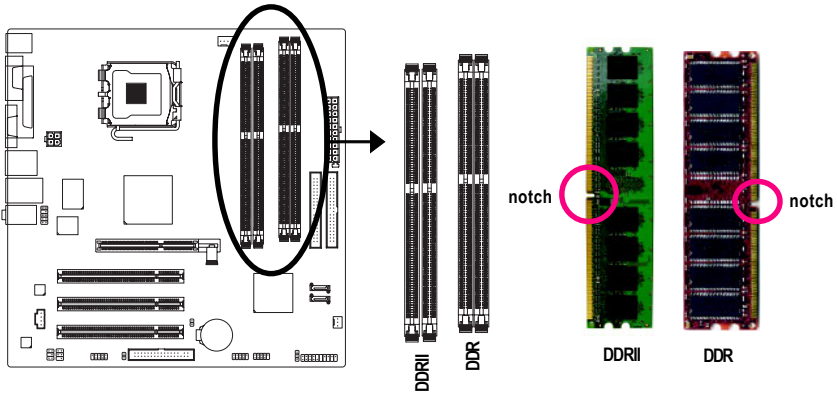

Fig.1

The DIMM socket has a notch, so the DIMM memory module can only fit in one direction. Insert the DIMM memory module vertically into the DIMM socket. Then push it down.

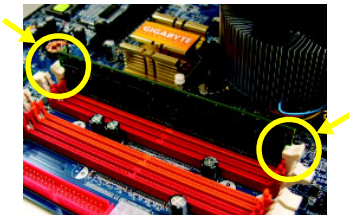

Fig.2

Close the plastic clip at both edges of the DIMM sockets to lock the DIMM module.

Reverse the installation steps when you wish to remove the DIMM module.

## 1-5 Installation of Expansion Cards

You can install your expansion card by following the steps outlined below:

1. Read the related expansion card's instruction document before installing the expansion card into the computer.
2. Remove your computer's chassis cover, screws and slot bracket from the computer.
3. Press the expansion card firmly into expansion slot in motherboard.
4. Be sure the metal contacts on the card are indeed seated in the slot.
5. Replace the screw to secure the slot bracket of the expansion card.
6. Replace your computer's chassis cover.
7. Power on the computer, if necessary, setup BIOS utility of expansion card from BIOS.
8. Install related driver from the operating system.

Installing a AGP expansion card:

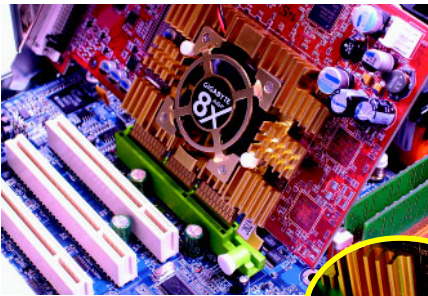

Please carefully pull out the small white-drawable bar at the end of the AGP slot when you try to install/uninstall the VGA card. Please align the VGA card to the onboard AGP slot and press firmly down on the slot. Make sure your VGA card is locked by the small white-drawable bar.

## 1-6 I/O Back Panel Introduction

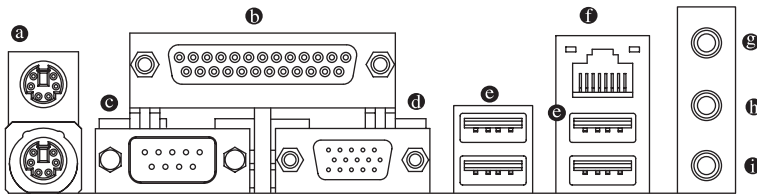

### Ⓐ PS/2 Keyboard and PS/2 Mouse Connector

To install a PS/2 port keyboard and mouse, plug the mouse to the upper port (green) and the keyboard to the lower port (purple).

### Ⓑ Parallel Port

The parallel port allows connection of a printer, scanner and other peripheral devices.

### Ⓒ Serial Port

Devices like mice, modems, and etc. can be connected to Serial port.

### Ⓓ VGA Port

Monitor can be connected to VGA port.

### Ⓔ USB Port

Before you connect your device(s) into USB connector(s), please make sure your device(s) such as USB keyboard, mouse, scanner, zip, speaker...etc. have a standard USB interface. Also make sure your OS supports USB controller. If your OS does not support USB controller, please contact OS vendor for possible patch or driver upgrade. For more information please contact your OS or device(s) vendors.

### Ⓕ LAN Port

The provided Internet connection is Fast Ethernet, supporting data transfer speeds of 10/100 Mbps.

### Ⓖ Line In

Devices like CD-ROM, walkman etc. can be connected to Line In jack.

### Ⓗ Line Out (Front Speaker Out)

Connect the stereo speakers, earphone or front surround channels to this connector.

### Ⓖ MIC In

Microphone can be connected to MIC In jack.



NOTE

You can use audio software to configure 2-/4-/6- channel audio functioning.



## 1-7 Connectors Introduction

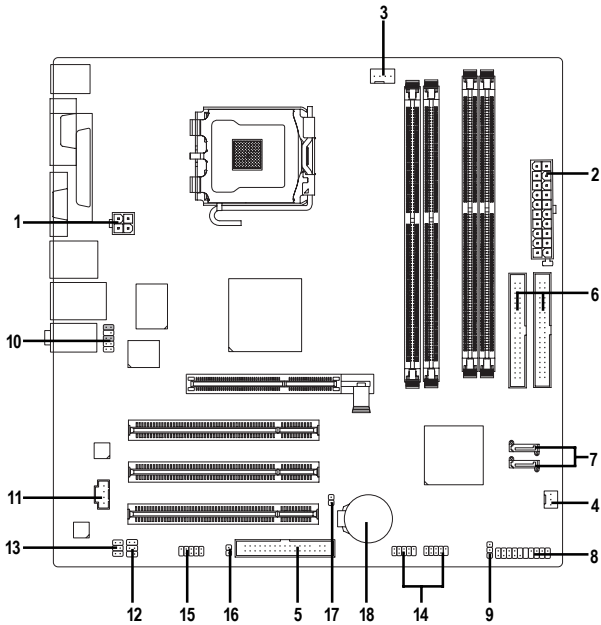

1)	ATX_12V	10)	F_AUDIO
2)	ATX (Power Connector)	11)	CD_IN
3)	CPU_FAN	12)	SPDIF_IO
4)	SYS_FAN	13)	SUR_CEN
5)	FDD	14)	F_USB1 / F_USB2
6)	IDE1 / IDE2	15)	COMB
7)	SATA0 / SATA1	16)	CI
8)	F_PANEL	17)	CLR_CMOS
9)	PWR_LED	18)	BATTERY

## 1/2) ATX\_12V / ATX (Power Connector)

With the use of the power connector, the power supply can supply enough stable power to all the components on the motherboard. Before connecting the power connector, please make sure that all components and devices are properly installed. Align the power connector with its proper location on the motherboard and connect tightly.

The ATX\_12V power connector mainly supplies power to the CPU. If the ATX\_12V power connector is not connected, the system will not start.

Caution!

Please use a power supply that is able to handle the system voltage requirements. It is recommended that a power supply that can withstand high power consumption be used (300W or greater). If a power supply is used that does not provide the required power, the result can lead to an unstable system or a system that is unable to start.

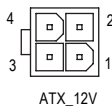
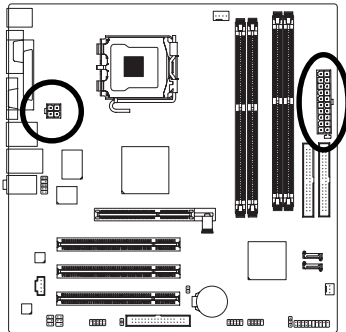

Pin No.	Definition
1	GND
2	GND
3	+12V
4	+12V

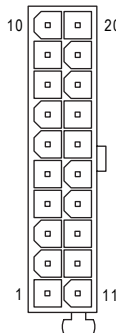

Pin No.	Definition
1	3.3V
2	3.3V
3	GND
4	+5V
5	GND
6	+5V
7	GND
8	Power Good
9	5V SB (stand by +5V)
10	+12V
11	3.3V
12	-12V
13	GND
14	PS_ON(soft on/off)
15	GND
16	GND
17	GND
18	-5V
19	+5V
20	+5V

### 3/4) CPU\_FAN / SYS\_FAN (Cooler Fan Power Connector)

The cooler fan power connector supplies a +12V power voltage via a 3-pin/4-pin(CPU\_FAN) power connector and possesses a foolproof connection design.

Most coolers are designed with color-coded power connector wires. A red power connector wire indicates a positive connection and requires a +12V power voltage. The black connector wire is the ground wire (GND).

Remember to connect the CPU/system fan cable to the CPU\_FAN/SYS\_FAN connector to prevent CPU damage or system hanging caused by overheating.

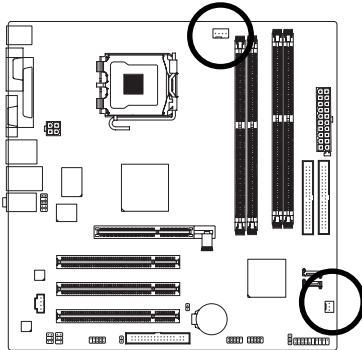

CPU\_FAN

CPU\_FAN :

Pin No.	Definition
1	GND
2	+12V / Speed Control
3	Sense
4	Speed Control



SYS\_FAN

SYS\_FAN :

Pin No.	Definition
1	GND
2	+12V
3	Sense

### 5) FDD (FDD Connector)

The FDD connector is used to connect the FDD cable while the other end of the cable connects to the FDD drive. The types of FDD drives supported are: 360 KB, 720 KB, 1.2 MB, 1.44 MB and 2.88 MB. Before attaching the FDD cable, please take note of the foolproof groove in the FDD connector.

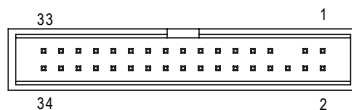
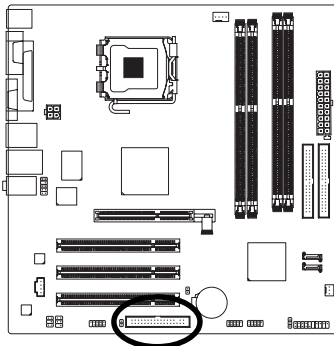

## 6) IDE1 / IDE2 (IDE Connector)

An IDE device connects to the computer via an IDE connector. One IDE connector can connect to one IDE cable, and the single IDE cable can then connect to two IDE devices (hard drive or optical drive). If you wish to connect two IDE devices, please set the jumper on one IDE device as Master and the other as Slave (for information on settings, please refer to the instructions located on the IDE device). Before attaching the IDE cable, please take note of the foolproof groove in the IDE connector.

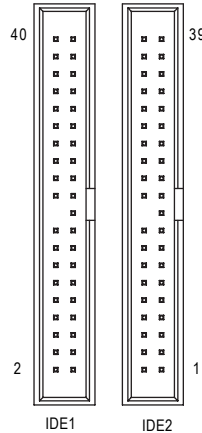
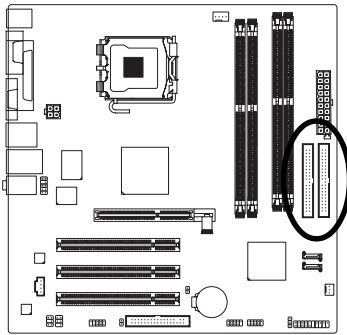

## 7) SATA0 / SATA1 (Serial ATA Connector)

Serial ATA can provide up to 150MB/s transfer rate. Please refer to the BIOS setting for the Serial ATA and install the proper driver in order to work properly.

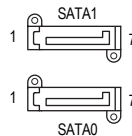
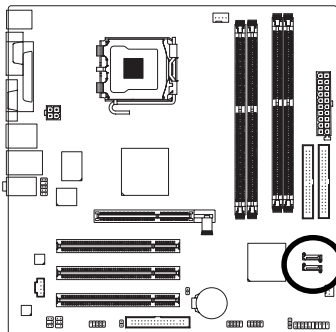

Pin No.	Definition
1	GND
2	TXP
3	TXN
4	GND
5	RXN
6	RXP
7	GND

## 8) F\_PANEL (Front Panel Connector)

Please connect the power LED, PC speaker, reset switch and power switch etc. of your chassis to the F\_PANEL connector according to the pin assignments below.

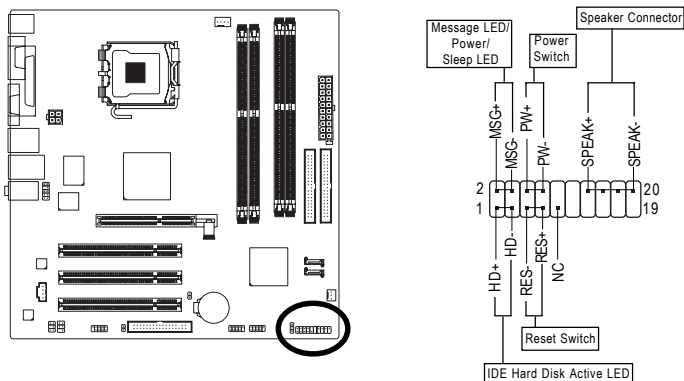

MSG (Message LED/Power/Sleep LED)	Pin 1: LED anode(+) Pin 2: LED cathode(-)
PW (Power Switch)	Open: Normal Close: Power On/Off
SPEAK (Speaker Connector)	Pin 1: Power Pin 2- Pin 3: NC Pin 4: Data(-)
HD (IDE Hard Disk Active LED)	Pin 1: LED anode(+) Pin 2: LED cathode(-)
RES (Reset Switch)	Open: Normal Close: Reset Hardware System
NC	NC

## 9) PWR\_LED

The PWR\_LED connector is connected with the system power indicator to indicate whether the system is on/off. It will blink when the system enters suspend mode(S1).

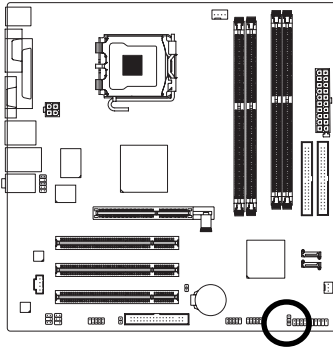

Pin No.	Definition
1	MPD+
2	MPD-
3	MPD-

## 10) F\_AUDIO (Front Audio Panel Connector)

Please make sure the pin assignment on the cable is the same as the pin assignment on the MB header. To find out if the chassis you are buying support front audio panel connector, please contact your dealer. If you want to use "Front Audio" connector, you must remove the jumpers from pins 5-6, 9-10.

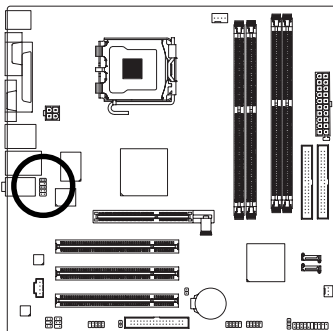

Pin No.	Definition
1	MIC
2	GND
3	MIC_BIAS
4	POWER
5	FrontAudio(R)
6	Rear Audio (R)/ Return R
7	NC
8	No Pin
9	FrontAudio (L)
10	Rear Audio (L)/ Return L

## 11) CD\_IN (CD IN Connector)

Connect CD-ROM or DVD-ROM audio out to the connector.

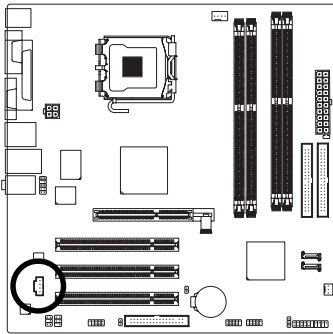

Pin No.	Definition
1	CD-L
2	GND
3	GND
4	CD-R

## 12) SPDIF\_IO (S/PDIF In/Out Connector)

The S/PDIF output is capable of providing digital audio to external speakers or compressed AC3 data to an external Dolby Digital Decoder. Use this feature only when your stereo system has digital input function. Use S/PDIF IN feature only when your device has digital output function. Be careful with the polarity of the SPDIF\_IO connector. Check the pin assignment carefully while you connect the S/PDIF cable, incorrect connection between the cable and connector will make the device unable to work or even damage it. For optional S/PDIF cable, please contact your local dealer.

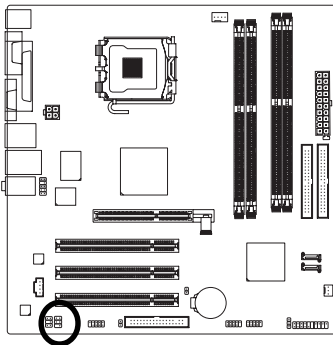

Pin No.	Definition
1	Power
2	No Pin
3	SPDIF
4	SPDIFI
5	GND
6	GND

### 13) SUR\_CEN (Surround Center Connector)

Please contact your nearest dealer for optional 6-Channel Audio Combo Kit.

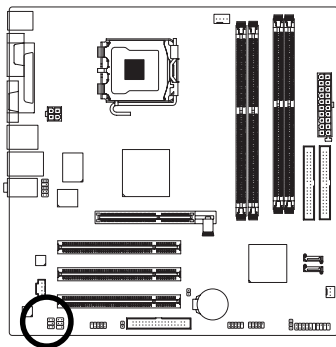

Pin No.	Definition
1	SUR OUTL
2	SUR OUTR
3	GND
4	No Pin
5	CENTER_OUT
6	BASS_OUT

### 14) F\_USB1 / F\_USB2 (Front USB Connectors)

Be careful with the polarity of the front USB connector. Check the pin assignment carefully while you connect the front USB cable, incorrect connection between the cable and connector will make the device unable to work or even damage it. For optional front USB cable, please contact your local dealer.

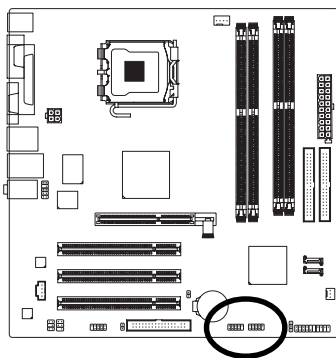

Pin No.	Definition
1	Power(5V)
2	Power(5V)
3	USB0 DX-
4	USB1 Dy-
5	USB0 DX+
6	USB1 Dy+
7	GND
8	GND
9	No Pin
10	NC



### 15) COMB (COMB Connector)

Be careful with the polarity of the COMB connector. Check the pin assignments while you connect the COMB cable. Please contact your nearest dealer for optional COMB cable.

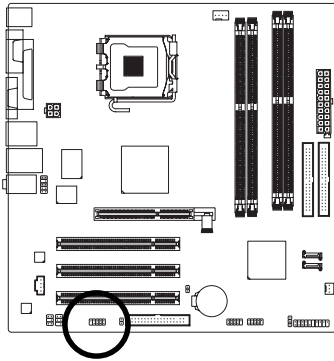

Pin No.	Definition
1	NDCDB-
2	NSINB
3	NSOUTB
4	NDTRB-
5	GND
6	NDSRB-
7	NRTSB-
8	NCTSB-
9	NRIB-
10	No Pin

### 16) CI (Chassis Intrusion, Case Open)

This 2-pin connector allows your system to detect if the chassis cover is removed. You can check the "Case Opened" status in BIOS Setup.

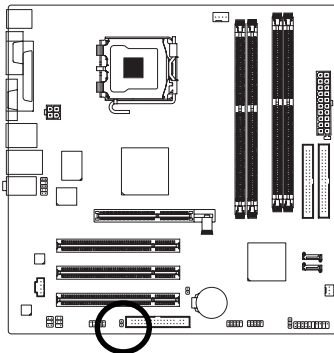

Pin No.	Definition
1	GND
2	Signal

## 17) CLR\_CMOS (Clear CMOS)

You may clear the CMOS data to its default values by this header. To clear CMOS, temporarily short the two pins. Default doesn't include the jumper to avoid improper use of this header.

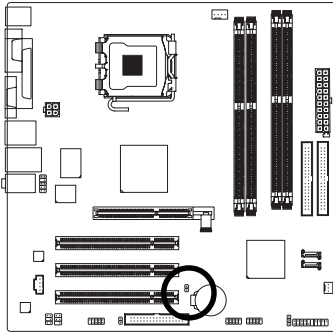

Open: Normal



Short: Clear CMOS

## 18) BATTERY

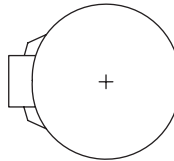
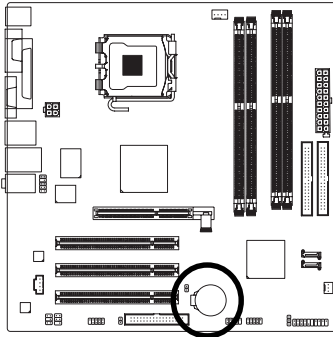

- ❖ Danger of explosion if battery is incorrectly replaced.
- ❖ Replace only with the same or equivalent type recommended by the manufacturer.
- ❖ Dispose of used batteries according to the manufacturer's instructions.

If you want to erase CMOS...

1. Turn off the computer and unplug the power cord.
2. Gently take out the battery and put it aside for about one minute.  
(Or you can use a metal object to connect the positive and negative pins in the battery holder to make them short for five seconds.)
3. Re-install the battery.
4. Plug the power cord in and turn on the computer.

## Chapter 2 BIOS Setup

BIOS (Basic Input and Output System) includes a CMOS SETUP utility which allows user to configure required settings or to activate certain system features.

The CMOS SETUP saves the configuration in the CMOS SRAM of the motherboard.

When the power is turned off, the battery on the motherboard supplies the necessary power to the CMOS SRAM.

When the power is turned on, pushing the <Del> button during the BIOS POST (Power-On Self Test) will take you to the CMOS SETUP screen. You can enter the BIOS setup screen by pressing "Ctrl + F1".

If you wish to upgrade to a new BIOS, either Gigabyte's Q-Flash or @BIOS utility can be used.

Q-Flash allows the user to quickly and easily update or backup BIOS without entering the operating system.

@BIOS is a Windows-based utility that does not require users to boot to DOS before upgrading BIOS but directly download and update BIOS from the Internet.

### CONTROL KEYS

<↑><↓><<<<>><>>>	Move to select item
<Enter>	Select Item
<Esc>	Main Menu - Quit and not save changes into CMOS Status Page Setup Menu and Option Page Setup Menu - Exit current page and return to Main Menu
<Page Up>	Increase the numeric value or make changes
<Page Down>	Decrease the numeric value or make changes
<F1>	General help, only for Status Page Setup Menu and Option Page Setup Menu
<F2>	Item Help
<F5>	Restore the previous CMOS value from CMOS, only for Option Page Setup Menu
<F6>	Load the fail-safe default CMOS value from BIOS default table
<F7>	Load the Optimized Defaults
<F8>	Q-Flash utility
<F9>	System Information
<F10>	Save all the CMOS changes, only for Main Menu

### Main Menu

The on-line description of the highlighted setup function is displayed at the bottom of the screen.

### Status Page Setup Menu / Option Page Setup Menu

Press F1 to pop up a small help window that describes the appropriate keys to use and the possible selections for the highlighted item. To exit the Help Window press <Esc>.



Because BIOS flashing is potentially risky, please do it with caution and avoid inadequate operation that may result in system malfunction.

## <F12> : Boot Menu

Select boot sequence for onboard (or add-on cards) device.

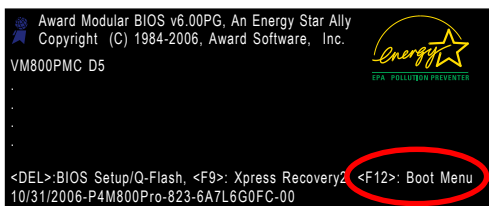

**<F12>: Boot Menu**

Use <↑> or <↓> to select a device, then press enter to accept . Press <ESC> to exit this menu.

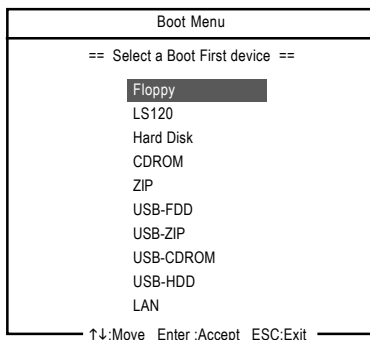

## The Main Menu (For example: BIOS Ver. : D5)

Once you enter Award BIOS CMOS Setup Utility, the Main Menu (as figure below) will appear on the screen. Use arrow keys to select among the items and press <Enter> to accept or enter the sub-menu.

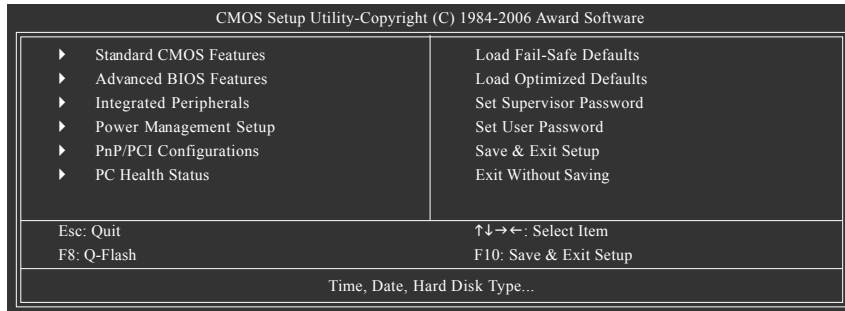

1. If you don't find the settings you want, press "Ctrl+F1" to access advanced options.
2. Select the **Load Optimized Defaults** item in the BIOS Setup when somehow the system is not stable as usual. This action makes the system reset to the default settings for stability.
3. The BIOS Setup menus described in this chapter are for reference only and may differ from the exact settings for your motherboard.

**■ Standard CMOS Features**

This setup page includes all the items in standard compatible BIOS.

**■ Advanced BIOS Features**

This setup page includes all the items of Award special enhanced features.

**■ Integrated Peripherals**

This setup page includes all onboard peripherals.

**■ Power Management Setup**

This setup page includes all the items of Green function features.

**■ PnP/PCI Configuration**

This setup page includes all the configurations of PCI & PnP ISA resources.

**■ PC Health Status**

This setup page is the System auto detect Temperature, voltage, fan, speed.

**■ Load Fail-Safe Defaults**

Fail-Safe Defaults indicates the value of the system parameters which the system would be in safe configuration.

**■ Load Optimized Defaults**

Optimized Defaults indicates the value of the system parameters which the system would be in best performance configuration.

**■ Set Supervisor Password**

Change, set, or disable password. It allows you to limit access to the system and Setup, or just to Setup.

**■ Set User Password**

Change, set, or disable password. It allows you to limit access to the system.

**■ Save & Exit Setup**

Save CMOS value settings to CMOS and exit setup.

**■ Exit Without Saving**

Abandon all CMOS value changes and exit setup.

## 2-1 Standard CMOS Features

CMOS Setup Utility-Copyright (C) 1984-2006 Award Software Standard CMOS Features		Item Help
Date (mm.dd.yy)	Wed, Nov 22 2006	Menu Level▶
Time (hh:mm:ss)	10:40:9	
▶ IDE Channel 0 Master	[None]	
▶ IDE Channel 0 Slave	[None]	
▶ IDE Channel 1 Master	[None]	
▶ IDE Channel 1 Slave	[None]	
▶ IDE Channel 2 Master	[None]	
▶ IDE Channel 3 Master	[None]	
Drive A	[1.44M, 3.5"]	
Floppy 3 Mode Support	[Disabled]	
Halt On	[All, But Keyboard]	
Base Memory	640K	
Extended Memory	447M	
↑↓→←: Move    Enter: Select    +/-/PU/PD: Value    F10: Save    ESC: Exit    F1: General Help F5: Previous Values    F6: Fail-Safe Defaults    F7: Optimized Defaults		

### ☞ Date

The date format is <week>, <month>, <day>, <year>.

- ▶▶ Week      The week, from Sun to Sat, determined by the BIOS and is display-only
- ▶▶ Month     The month, Jan. Through Dec.
- ▶▶ Day        The day, from 1 to 31 (or the maximum allowed in the month)
- ▶▶ Year        The year, from 1999 through 2098

### ☞ Time

The times format in <hour> <minute> <second>. The time is calculated base on the 24-hour military-time clock. For example, 1 p.m. is 13:00:00.

### ☞ IDE Channel 0/1 Master, Slave

- ▶▶ IDE HDD Auto-Detection Press "Enter" to select this option for automatic device detection.
- ▶▶ IDE Device Setup. You can use one of three methods:
  - Auto        Allows BIOS to automatically detect IDE/SATA devices during POST.(default)
  - None        Select this if no IDE/SATA devices are used and the system will skip the automatic detection step and allow for faster system start up.
  - Manual     User can manually input the correct settings
- ▶▶ Access Mode Use this to set the access mode for the hard drive. The four options are: CHS/LBA/Large/Auto(default:Auto)

### ☞ IDE Channel 2/3 Master

- ▶▶ IDE HDD Auto-Detection Press "Enter" to select this option for automatic device detection.
- ▶▶ Extended IDE Drive    IDE/SATA devices setup. You can use one of two methods:
  - Auto        Allows BIOS to automatically detect SATA IDE devices during POST. (Default value)
  - None        Select this if no SATA devices are used and the system will skip the automatic detection step and allow for faster system start up.
- ▶▶ Access Mode Use this to set the access mode for the hard drive. The two options are: Large/Auto(default:Auto)

» Capacity Capacity of currently installed hard disk.

Hard drive information should be labeled on the outside drive casing. Enter the appropriate option based on this information.

- » Cylinder Number of cylinders
- » Head Number of heads
- » Precomp Write precomp
- » Landing Zone Landing zone
- » Sector Number of sectors

#### ☞ Drive A

The category identifies the types of floppy disk drive A that has been installed in the computer.

- » None No floppy drive installed
- » 360K, 5.25" 5.25 inch PC-type standard drive; 360K byte capacity.
- » 1.2M, 5.25" 5.25 inch AT-type high-density drive; 1.2M byte capacity (3.5 inch when 3 Mode is Enabled).
- » 720K, 3.5" 3.5 inch double-sided drive; 720K byte capacity
- » 1.44M, 3.5" 3.5 inch double-sided drive; 1.44M byte capacity. (Default value)
- » 2.88M, 3.5" 3.5 inch double-sided drive; 2.88M byte capacity.

#### ☞ Floppy 3 Mode Support (for Japan Area)

- » Disabled Normal Floppy Drive. (Default value)
- » Drive A Drive A is 3 mode Floppy Drive.

#### ☞ Halt on

The category determines whether the computer will stop if an error is detected during power up.

- » No Errors The system boot will not stop for any error that may be detected and you will be prompted.
- » All Errors Whenever the BIOS detects a non-fatal error the system will be stopped.
- » All, But Keyboard The system boot will not stop for a keyboard error; it will stop for all other errors. (Default value)
- » All, But Diskette The system boot will not stop for a disk error; it will stop for all other errors.
- » All, But Disk/Key The system boot will not stop for a keyboard or disk error; it will stop for all other errors.

#### ☞ Memory

The category is display-only which is determined by POST (Power On Self Test) of the BIOS.

##### » Base Memory

The POST of the BIOS will determine the amount of base (or conventional) memory installed in the system.

The value of the base memory is typically 512K for systems with 512K memory installed on the motherboard, or 640K for systems with 640K or more memory installed on the motherboard.

##### » Extended Memory

The BIOS determines how much extended memory is present during the POST.

This is the amount of memory located above 1 MB in the CPU's memory address map.

## 2-2 Advanced BIOS Features

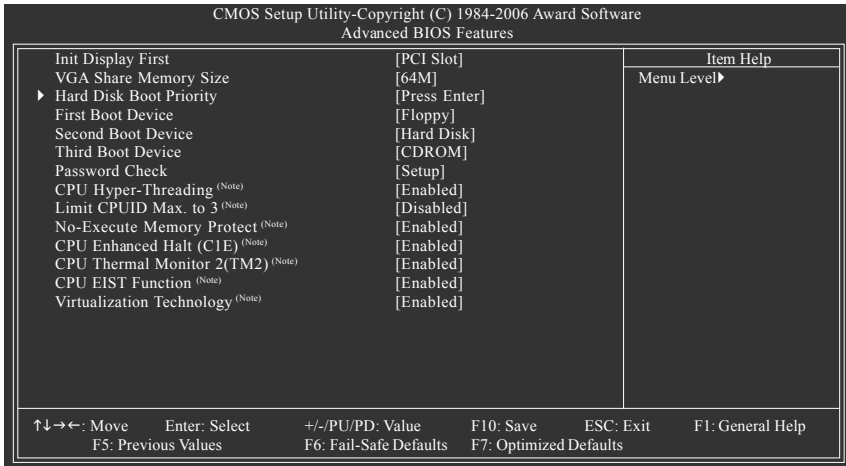

### ☞ Init Display First

This feature allows you to select the first initiation of the monitor display from which card when you install a PCI card and a PCI Express VGA card on the motherboard.

- ▶▶ PCI Slot      Set Init display first to PCI Slot. (Default value)
- ▶▶ Onboard/AGP    Set Init display first to Onboard/AGP.

### ☞ VGA Share Memory Size

- ▶▶ Disabled      Disable this function.
- ▶▶ 16M            Set VGA share memory size to 16 MB.
- ▶▶ 32M            Set VGA share memory size to 32 MB.
- ▶▶ 64M            Set VGA share memory size to 64 MB. (Default value)

### ☞ Hard Disk Boot Priority

Select boot sequence for onboard(or add-on cards) SCSI, RAID, etc.

Use <↑> or <↓> to select a device, then press<+> to move it up, or <-> to move it down the list. Press <ESC> to exit this menu.

(Note) This item will show up when you install a processor that supports this function.



### ☞ **First / Second / Third Boot Device**

- ▶▶ Floppy Select your boot device priority by Floppy.
- ▶▶ LS120 Select your boot device priority by LS120.
- ▶▶ Hard Disk Select your boot device priority by Hard Disk.
- ▶▶ CDROM Select your boot device priority by CDROM.
- ▶▶ ZIP Select your boot device priority by ZIP.
- ▶▶ USB-FDD Select your boot device priority by USB-FDD.
- ▶▶ USB-ZIP Select your boot device priority by USB-ZIP.
- ▶▶ USB-CDROM Select your boot device priority by USB-CDROM.
- ▶▶ USB-HDD Select your boot device priority by USB-HDD.
- ▶▶ Legacy LAN Select your boot device priority by Legacy LAN.
- ▶▶ Disabled Disable this function.

### ☞ **Password Check**

- ▶▶ System The system can not boot and can not access to Setup page will be denied if the correct password is not entered at the prompt.
- ▶▶ Setup The system will boot, but access to Setup will be denied if the correct password is not entered at the prompt. (Default value)

### ☞ **CPU Hyper-Threading** <sup>(Note)</sup>

- ▶▶ Enabled Enable CPU Hyper Threading Feature. Please note that this feature is only working for operating system with multi processors mode supported. (Default value)
- ▶▶ Disabled Disable CPU Hyper Threading.

### ☞ **Limit CPUID Max. to 3** <sup>(Note)</sup>

- ▶▶ Enabled Limit CPUID Maximum value to 3 when use older OS like NT4.
- ▶▶ Disabled Disable CPUID Limit for windows XP. (Default value)

### ☞ **No-Execute Memory Protect** <sup>(Note)</sup>

- ▶▶ Enabled Enable No-Execute Memory Protect function. (Default value)
- ▶▶ Disabled Disable No-Execute Memory Protect function.

### ☞ **CPU Enhanced Halt (C1E)** <sup>(Note)</sup>

- ▶▶ Enabled Enable CPU Enhanced Halt (C1E) function. (Default value)
- ▶▶ Disabled Disable CPU Enhanced Halt (C1E) function.

### ☞ **CPU Thermal Monitor 2 (TM2)** <sup>(Note)</sup>

- ▶▶ Enabled Enable CPU Thermal Monitor 2 (TM2) function. (Default value)
- ▶▶ Disabled Disable CPU Thermal Monitor 2 (TM2) function.

### ☞ **CPU EIST Function** <sup>(Note)</sup>

- ▶▶ Enabled Enable CPU EIST function. (Default value)
- ▶▶ Disabled Disable EIST function.

### ☞ **Virtualization Technology** <sup>(Note)</sup>

- ▶▶ Enabled Enable Virtualization Technology function. (Default value)
- ▶▶ Disabled Disable Virtualization Technology function.

(Note) This item will show up when you install a processor that supports this function.

## 2-3 Integrated Peripherals

CMOS Setup Utility-Copyright (C) 1984-2006 Award Software Integrated Peripherals		
OnChip IDE Channel 0	[Enabled]	Item Help
OnChip IDE Channel 1	[Enabled]	Menu Level▶
VIA Onboard LAN	[Enabled]	
OnBoard LAN Boot ROM	[Disabled]	
OnChip Serial ATA	[Enabled]	
SATA Mode	[IDE]	
AC97 Audio	[Auto]	
USB 1.1 Controller	[Enabled]	
USB 2.0 Controller	[Enabled]	
USB Keyboard Support	[Disabled]	
USB Mouse Support	[Disabled]	
Legacy USB storage detect	[Enabled]	
Onboard Serial Port 1	[3F8/IRQ4]	
Onboard Serial Port 2	[2F8/IRQ3]	
Onboard Parallel Port	[378/IRQ7]	
Parallel Port Mode	[SPP]	
x EPP Mode Select	EPP1,7	

↑↓←→: Move    Enter: Select    +/-/PU/PD: Value    F10: Save    ESC: Exit    F1: General Help  
 F5: Previous Values    F6: Fail-Safe Defaults    F7: Optimized Defaults

### ☞ OnChip IDE Channel0

- ▶▶ Enabled      Enable onboard 1st channel IDE port. (Default value)
- ▶▶ Disabled      Disable onboard 1st channel IDE port.

### ☞ OnChip IDE Channel1

- ▶▶ Enabled      Enable onboard 2nd channel IDE port. (Default value)
- ▶▶ Disabled      Disable onboard 2nd channel IDE port.

### ☞ VIA Onboard LAN

- ▶▶ Enabled      Enable VIA onboard LAN function. (Default value)
- ▶▶ Disabled      Disable this function.

### ☞ OnBoard LAN Boot ROM

This function decide whether to invoke the boot ROM of the onboard LAN chip.

- ▶▶ Enabled      Enable this function.
- ▶▶ Disabled      Disable this function. (Default value)

### ☞ OnChip Serial ATA

- ▶▶ Enabled      Enable VT8237R Plus Serial ATA supported. (Default value)
- ▶▶ Disabled      Disable VT8237R Plus Serial ATA supported.

### ☞ SATA Mode

- ▶▶ RAID          Set onboard SATA mode to RAID.
- ▶▶ IDE            Set onboard SATA mode to IDE. (Default value)

### ☞ AC97 Audio

- ▶▶ Auto          Enable onboard AC'97 audio function. (Default value)
- ▶▶ Disabled      Disable this function.

### ☞ USB 1.1 Controller

- ▶▶ Disabled      Disable USB 1.1 controller.
- ▶▶ Enabled      Enable USB 1.1 controller. (Default value)

### ☞ **USB 2.0 Controller**

- ▶▶ Disabled      Disable USB 2.0 controller.
- ▶▶ Enabled      Enable USB 2.0 controller. (Default value)

### ☞ **USB Keyboard Support**

- ▶▶ Enabled      Enable USB keyboard support.
- ▶▶ Disabled      Disable USB keyboard support. (Default value)

### ☞ **USB Mouse Support**

- ▶▶ Enabled      Enable USB mouse support.
- ▶▶ Disabled      Disable USB mouse support. (Default value)

### ☞ **Legacy USB storage detect**

This option allows users to decide whether to detect USB storage devices, including USB flash drives and USB hard drives during POST.

- ▶▶ Enabled      BIOS will scan all USB storage devices. (Default value)
- ▶▶ Disabled      Disable this function.

### ☞ **Onboard Serial Port 1**

- ▶▶ Auto          BIOS will automatically setup the Serial port 1 address.
- ▶▶ 3F8/IRQ4    Enable onboard Serial port 1 and address is 3F8/IRQ4. (Default value)
- ▶▶ 2F8/IRQ3    Enable onboard Serial port 1 and address is 2F8/IRQ3.
- ▶▶ 3E8/IRQ4    Enable onboard Serial port 1 and address is 3E8/IRQ4.
- ▶▶ 2E8/IRQ3    Enable onboard Serial port 1 and address is 2E8/IRQ3.
- ▶▶ Disabled    Disable onboard Serial port 1.

### ☞ **Onboard Serial Port 2**

- ▶▶ Auto          BIOS will automatically set up the Serial port 2 address.
- ▶▶ 3F8/IRQ4    Enable onboard Serial port 2 and address is 3F8/IRQ4.
- ▶▶ 2F8/IRQ3    Enable onboard Serial port 2 and address is 2F8/IRQ3. (Default value)
- ▶▶ 3E8/IRQ4    Enable onboard Serial port 2 and address is 3E8/IRQ4.
- ▶▶ 2E8/IRQ3    Enable onboard Serial port 2 and address is 2E8/IRQ3.
- ▶▶ Disabled    Disable onboard Serial port 2.

### ☞ **Onboard Parallel Port**

- ▶▶ Disabled    Disable onboard LPT port.
- ▶▶ 378/IRQ7    Enable onboard LPT port and address is 378/IRQ7. (Default value)
- ▶▶ 278/IRQ5    Enable onboard LPT port and address is 278/IRQ5.
- ▶▶ 3BC/IRQ7    Enable onboard LPT port and address is 3BC/IRQ7.

### ☞ **Parallel Port Mode**

- ▶▶ SPP          Using Parallel port as Standard Parallel Port. (Default value)
- ▶▶ EPP          Using Parallel port as Enhanced Parallel Port.
- ▶▶ ECP          Using Parallel port as Extended Capabilities Port.
- ▶▶ ECP+EPP    Using Parallel port as ECP and EPP mode.

### ☞ **EPP Mode Select**

- ▶▶ EPP1.7      Set EPP Mode to EPP1.7. (Default value)
- ▶▶ EPP1.9      Set EPP Mode to EPP1.9.

## 2-4 Power Management Setup

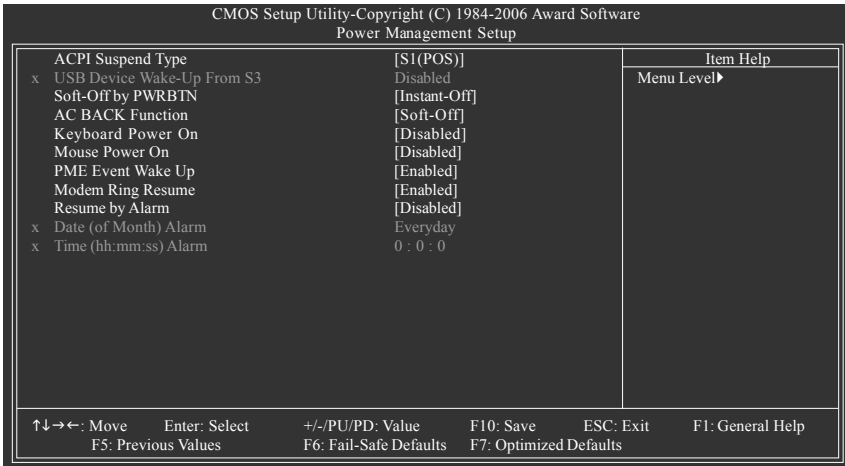

### ☞ ACPI Suspend Type

- ▶▶ S1(POS)    Set ACPI suspend type to S1/POS(Power On Suspend). (Default value)
- ▶▶ S3(STR)    Set ACPI suspend type to S3/STR(Suspend To RAM).

### ☞ USB Device Wake-Up From S3

- ▶▶ Disabled    Disable USB Device Wake-Up from S3. (Default value)
- ▶▶ Enabled    Enable USB Device Wake-Up from S3.

### ☞ Soft-Off by PWRBTN

- ▶▶ Instant-Off    Press power button then Power off instantly. (Default value)
- ▶▶ Delay 4 Sec.    Press power button 4 sec. to Power off. Enter suspend if button is pressed less than 4 sec.

### ☞ AC BACK Function

- ▶▶ Memory    When AC-power back to the system, the system will be back to the last state before AC-power is lost.
- ▶▶ Soft-Off    When AC-power back to the system, the system will be in "Off" state. (Default value)
- ▶▶ Full-On    When AC-power back to the system, the system always in "On" state.

### ☞ Keyboard Power On

- ▶▶ Password    Enter from 1 to 8 characters to set the Keyboard Power On Password.
- ▶▶ Disabled    Disable this function. (Default value)
- ▶▶ Keyboard 98    If your keyboard have "POWER Key" button, you can press the key to power on the system.

### ☞ **Mouse Power On**

- ▶▶ Disabled      Disable this function. (Default value)
- ▶▶ Enabled        Double click on PS/2 mouse left button to power on the system.

### ☞ **PME Event Wake Up**

This feature requires an ATX power supply that provides at least 1A on the 5VSB lead.

- ▶▶ Disabled      Disable this function.
- ▶▶ Enabled        Enable PME as wake up event. (Default value)

### ☞ **Modem Ring Resume**

An incoming call via modem can awake the system from any suspend state.

- ▶▶ Disabled      Disable Modem Ring Resume function.
- ▶▶ Enabled        Enable Modem Ring Resume function. (Default value)

### ☞ **Resume by Alarm**

You can set "Resume by Alarm" item to Enabled and key in Date/Time to power on system.

- ▶▶ Disabled      Disable this function. (Default value)
- ▶▶ Enabled        Enable alarm function to POWER ON system.

If Resume by Alarm is Enabled.

- ▶▶ Date (of Month) Alarm :      Everyday, 1~31
- ▶▶ Time (hh: mm: ss) Alarm:    (0~23) : (0~59) : (0~59)

## 2-5 PnP/PCI Configurations

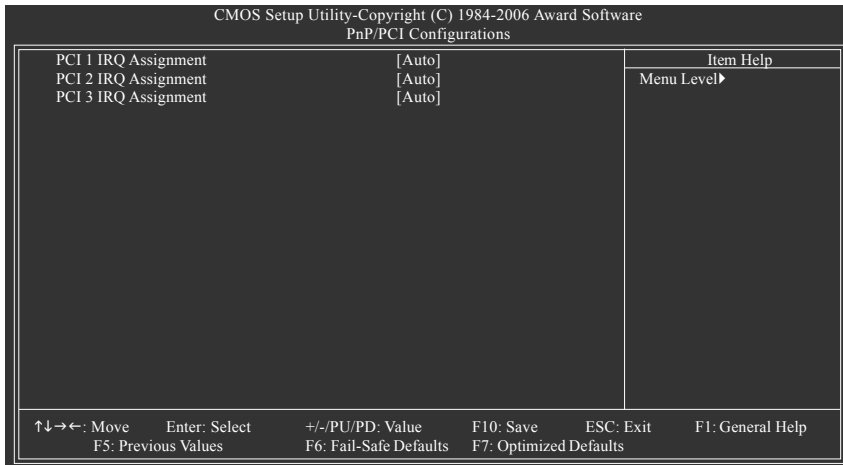

### ☞ PCI 1 IRQ Assignment

- ▶▶ Auto Auto assign IRQ to PCI 1. (Default value)
- ▶▶ 3,4,5,7,9,10,11,12,14,15 Set IRQ 3,4,5,7,9,10,11,12,14,15 to PCI 1.

### ☞ PCI 2 IRQ Assignment

- ▶▶ Auto Auto assign IRQ to PCI 2. (Default value)
- ▶▶ 3,4,5,7,9,10,11,12,14,15 Set IRQ 3,4,5,7,9,10,11,12,14,15 to PCI 2.

### ☞ PCI 3 IRQ Assignment

- ▶▶ Auto Auto assign IRQ to PCI 3. (Default value)
- ▶▶ 3,4,5,7,9,10,11,12,14,15 Set IRQ 3,4,5,7,9,10,11,12,14,15 to PCI 3.

## 2-6 PC Health Status

CMOS Setup Utility-Copyright (C) 1984-2006 Award Software		Item Help
PC Health Status		Menu Level▶
Reset Case Open Status	[Disabled]	
Case Opened	No	
VCORE	OK	
DDR POWER	OK	
+3.3V	OK	
+12V	OK	
System Temperature	29°C/84°F	
CPU Temperature	30°C/86°F	
Current SYS FAN Speed	0 RPM	
Current CPU FAN Speed	3245 RPM	
System Warning Temp.	[Disabled]	
CPU Warning Temp.	[Disabled]	
SYS FAN Fail Warning	[Disabled]	
CPU FAN Fail Warning	[Disabled]	
CPU Smart FAN Control <sup>(Note)</sup>	[Enabled]	

↑↓→←: Move    Enter: Select    +/-/PU/PD: Value    F10: Save    ESC: Exit    F1: General Help  
 F5: Previous Values    F6: Fail-Safe Defaults    F7: Optimized Defaults

### ☞ Reset Case Open Status

- ▶▶ Disabled            Don't reset case open status. (Default value)
- ▶▶ Enabled             Clear case open status at next boot.

### ☞ Case Opened

If the case is closed, "Case Opened" will show "No". If the case has been opened, "Case Opened" will show "Yes". If you want to reset "Case Opened" value, set "Reset Case Open Status" to **Enabled** then save BIOS setup and restart your system.

### ☞ Current Voltage(V) VCORE / DDR POWER / +3.3V / +12V

- ▶▶ Detect system's voltage status automatically.

### ☞ System / CPU Temperature

- ▶▶ Detect system / CPU temperature automatically.

### ☞ Current SYS / CPU FAN Speed (RPM)

- ▶▶ Detect system / CPU Fan speed status automatically.

### ☞ System Warning Temperature

- ▶▶ 60°C / 140°F            Monitor system temperature at 60°C / 140°F.
- ▶▶ 70°C / 158°F            Monitor system temperature at 70°C / 158°F.
- ▶▶ 80°C / 176°F            Monitor system temperature at 80°C / 176°F.
- ▶▶ 90°C / 194°F            Monitor system temperature at 90°C / 194°F.
- ▶▶ Disabled                Disable this function. (Default value)

### ☞ CPU Warning Temperature

- ▶▶ 60°C / 140°F Monitor CPU temperature at 60°C / 140°F.
- ▶▶ 70°C / 158°F Monitor CPU temperature at 70°C / 158°F.
- ▶▶ 80°C / 176°F Monitor CPU temperature at 80°C / 176°F.
- ▶▶ 90°C / 194°F Monitor CPU temperature at 90°C / 194°F.
- ▶▶ Disabled Disable this function. (Default value)

### ☞ SYS / CPU FAN Fail Warning

- ▶▶ Disabled Disable fan fail warning function. (Default value)
- ▶▶ Enabled Enable fan fail warning function.

### ☞ CPU Smart FAN Control <sup>(Note)</sup>

- ▶▶ Disabled Disable this function.
- ▶▶ Enabled When this function is enabled, CPU fan will run at different speed depending on CPU temperature. Users can adjust the fan speed with Easy Tune based on their requirements. (Default value)

(Note) This function is only supported on 4-pin CPU fans.



## 2-7 Load Fail-Safe Defaults

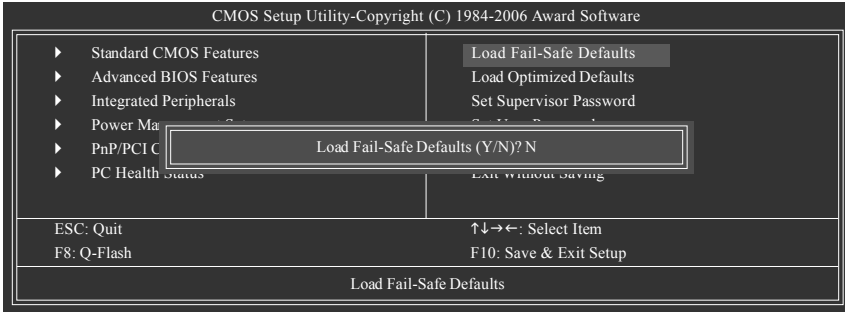

Fail-Safe defaults contain the most appropriate values of the system parameters that allow minimum system performance.

## 2-8 Load Optimized Defaults

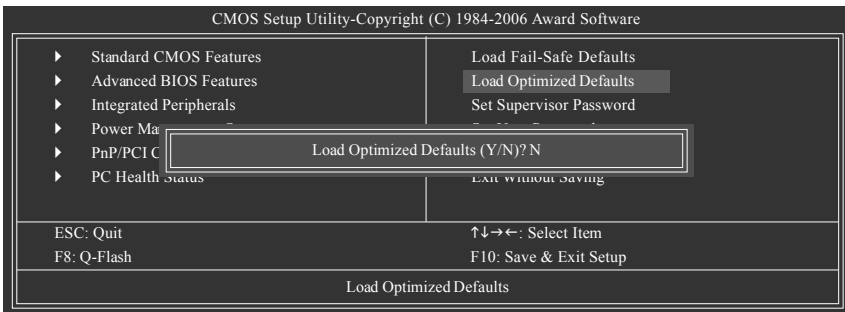

Selecting this field loads the factory defaults for BIOS and Chipset Features which the system automatically detects.

## 2-9 Set Supervisor/User Password

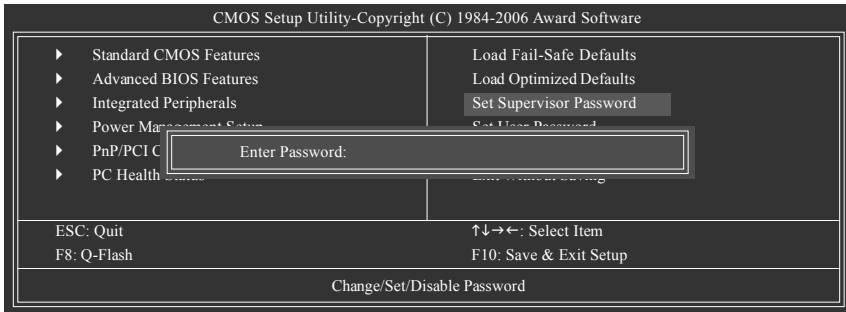

When you select this function, the following message will appear at the center of the screen to assist you in creating a password.

Type the password, up to eight characters, and press <Enter>. You will be asked to confirm the password. Type the password again and press <Enter>. You may also press <Esc> to abort the selection and not enter a password.

To disable password, just press <Enter> when you are prompted to enter password. A message "PASSWORD DISABLED" will appear to confirm the password being disabled. Once the password is disabled, the system will boot and you can enter Setup freely.

The BIOS Setup program allows you to specify two separate passwords:

SUPERVISOR PASSWORD and a USER PASSWORD. When disabled, anyone may access all BIOS Setup program function. When enabled, the Supervisor password is required for entering the BIOS Setup program and having full configuration fields, the User password is required to access only basic items.

If you select "System" at "Password Check" in Advance BIOS Features Menu, you will be prompted for the password every time the system is rebooted or any time you try to enter Setup Menu.

If you select "Setup" at "Password Check" in Advance BIOS Features Menu, you will be prompted only when you try to enter Setup.

## 2-10 Save & Exit Setup

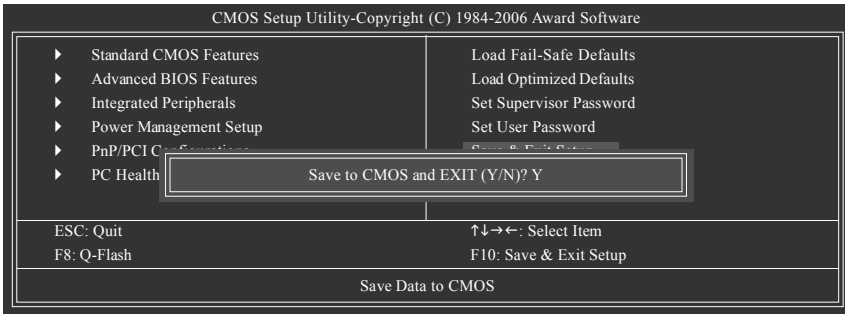

Type "Y" will quit the Setup Utility and save the user setup value to RTC CMOS.

Type "N" will return to Setup Utility.

## 2-11 Exit Without Saving

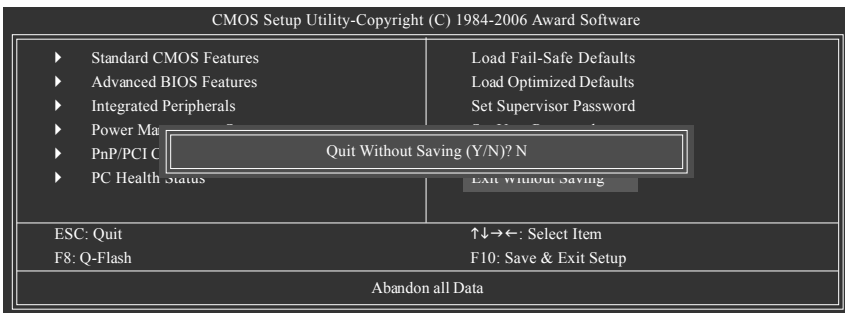

Type "Y" will quit the Setup Utility without saving to RTC CMOS.

Type "N" will return to Setup Utility.

Ruled lines for writing.

## Chapter 3 Drivers Installation



Pictures below are shown in Windows XP.

Insert the driver CD-title that came with your motherboard into your CD-ROM drive, the driver CD-title will auto start and show the installation guide. If not, please double click the CD-ROM device icon in "My computer", and execute the Setup.exe.

### 3-1 Install Chipset Drivers

After insert the driver CD, "Xpress Install" will scan automatically the system and then list all the drivers that recommended to install. The "Xpress Install" uses the "Click and Go" technology to install the drivers automatically. Just select the drivers you want then click the "GO" button. The "Xpress Install" will execute the installation for you automatically.

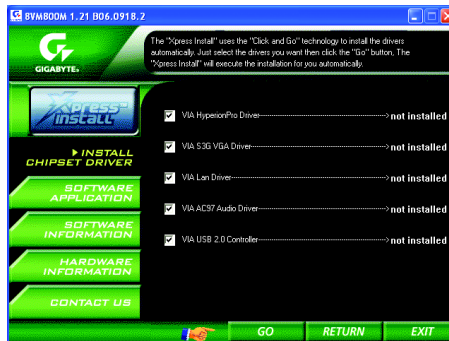

Some device drivers will restart your system automatically. After restarting your system the "Xpress Install" will continue to install other drivers.

System will reboot automatically after install the drivers, afterward you can install others application.



1. For USB2.0 driver support under Windows XP operating system, please use Windows Service Pack. After install Windows Service Pack, it will show a question mark "?" in "Universal Serial Bus controller" under "Device Manager". Please remove the question mark and restart the system (System will auto-detect the right USB2.0 driver).
2. Some Nvidia graphics cards might have display problems under Windows 2000/XP. Please install the driver from the following location:  
D:\Chipset\Nvidia\WinXP\_2K\Setup.exe (we assume your CD-ROM drive is D:).

## 3-2 Software Application

This page displays all the tools that Gigabyte developed and some free software. You can click an item to install it.

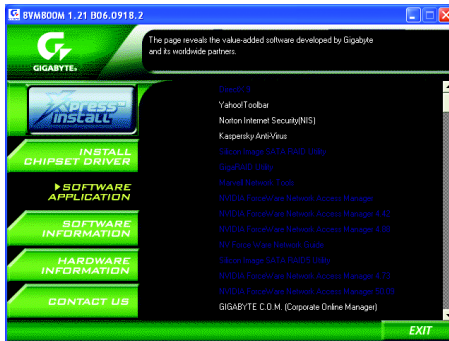

## 3-3 Software Information

This page lists the contents of software and drivers in this CD-title.

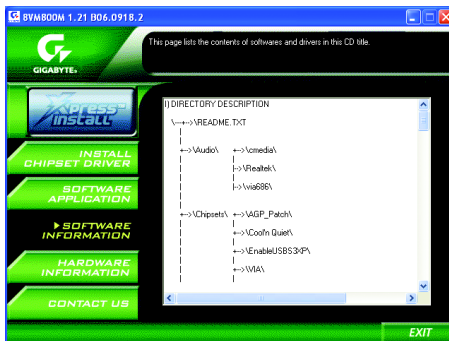

### 3-4 Hardware Information

This page lists all device you have for this motherboard.



### 3-5 Contact Us

Please see the last page for details.







## Chapter 4 Appendix

### 4-1 Unique Software Utilities

(Not all model support these Unique Software Utilities, please check your MB features.)

#### 4-1-1 EasyTune 5 Introduction

EasyTune 5 presents the most convenient Windows based system performance enhancement and manageability utility. Featuring several powerful yet easy to use tools such as 1) Overclocking for enhancing system performance, 2) C.I.A. and M.I.B. for special enhancement for CPU and Memory, 3) Smart-Fan control for managing fan speed control of both CPU cooling fan and North-Bridge Chipset cooling fan, 4) PC health for monitoring system status. <sup>(Note)</sup>

#### User Interface Overview



	Button / Display	Description
1.	Overclocking	Enters the Overclocking setting page
2.	C.I.A./C.I.A.2 and M.I.B./M.I.B.2	Enters the C.I.A./2 and M.I.B./2 setting page
3.	Smart-Fan	Enters the Smart-Fan setting page
4.	PC Health	Enters the PC Health setting page
5.	GO	Confirmation and Execution button
6.	"Easy Mode" & "Advance Mode"	Toggles between Easy and Advance Mode
7.	Display screen	Display panel of CPU frequency
8.	Function display LEDs	Shows the current functions status
9.	GIGABYTE Logo	Log on to GIGABYTE website
10.	Help button	Display EasyTune™ 5 Help file
11.	Exit or Minimize button	Quit or Minimize EasyTune™ 5 software

(Note) EasyTune 5 functions may vary depending on different motherboards.

## 4-1-2 Xpress Recovery2 Introduction



Xpress Recovery2 is designed to provide quick backup and restoration of hard disk data. Supporting Microsoft operating systems including Windows XP/2000/NT/98/Me and DOS, and file systems including FAT16, FAT32, and NTFS, Xpress Recovery2 is able to back up data on hard disks on PATA and SATA IDE controllers. After Xpress Recovery2 is executed from CD-ROM for the first time, it will stay permanent in your hard disk. If you wish to run Xpress Recovery2 later, you can simply press F9 during system bootup to enter Xpress Recovery2 without the CD-ROM.

### System requirements:

1. Intel x86 platforms
2. At least 64M bytes of system memory
3. VESA-supported VGA cards

### How to use the Xpress Recovery2

Initial access by booting from CD-ROM and subsequent access by pressing the F9 key:

Steps: After entering BIOS Setup, go to **Advanced BIOS Feature** and set to boot from CD-ROM. Save the settings and exit the BIOS Setup. Insert the provided driver CD into your CD-ROM drive. Upon system restart, the message which says "Boot from CD/DVD:" will appear in the bottom left corner of the screen. Press any key to enter Xpress Recovery2.

After the steps above are completed, subsequent access to Xpress Recovery2 can be made by simply pressing the <F9> key during system power-on.



Boot from CD/DVD:

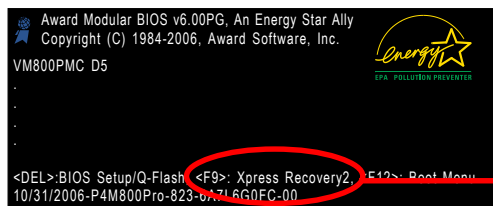

<F9>: Xpress Recovery2



1. If you have already entered Xpress Recovery2 by booting from the CD-ROM, you can enter Xpress Recovery2 by pressing the <F9> key in the future.
2. System storage capacity and the reading/writing speed of the hard disk will affect the data backup speed.
3. It is recommended that Xpress Recovery2 be immediately installed once you complete installations of OS and all required drivers as well as software.

## The Main Screen of Xpress Recovery2



### 1. RESTORE:

Restore the backed-up data to your hard disk. (This button will not appear if there is no backup file.)

### 2. BACKUP:

Back up data from hard disk.

### 3. REMOVE:

Remove previously-created backup files to release disk space.

(This button will not appear if there is no backup file.)

### 4. REBOOT:

Exit the main screen and restart the system.

### Limitations:

1. Not compatible to Xpress Recovery.
2. For the use of Xpress Recovery2, a primary partition must be reserved.
3. Xpress Recovery2 will store the backup file at the end of the hard disk, so free space available on the hard disk for the backup file must be allocated in advance. (A minimum 4GB is recommended but the actual space is dependent on the size of the data to be backed up)
4. Capable of backing up hard disks installed with Windows operating systems including DOS and Windows XP/2000/NT/9x/Me.
5. USB hard disks are currently not supported.
6. Does not support RAID/AHCI (class code 0104/0106) hard disks.
7. Capable of backing up and restoring only the first physical hard disk.

Hard disks detection sequence is as follows:

- a. PATA IDE primary channel
- b. PATA IDE secondary channel
- c. SATA IDE channel 1
- d. SATA IDE channel 2
- e. SATA IDE channel 3
- f. SATA IDE channel 4

### Precautions:

1. When using hard disks with more than 128G under Windows 2000, be sure to execute the EnableBigLba.exe program from the driver CD before data backup.
2. It is normal that data backup takes longer time than data restoration.
3. Xpress Recovery2 is compliant with the GPL regulations.
4. On a few motherboards based on Nvidia chipsets, BIOS update is required for Xpress Recovery2 to correctly identify RAID and SATA IDE mode. Please contact your motherboard manufacturer.

## 4-1-3 Flash BIOS Method Introduction



### Method 1 : Q-Flash™ Utility

Q-Flash™ is a BIOS flash utility embedded in Flash ROM. With this utility, users only have to stay in the BIOS menu when they want to update BIOS. Q-Flash™ allows users to flash BIOS without any utility in DOS or Windows. Using Q-Flash™ indicating no more fooling around with any complicated instructions and operating system since it is in the BIOS menu.



Please note that because updating BIOS has potential risk, please do it with caution!! We are sorry that Gigabyte Technology Co., Ltd is not responsible for damages of system because of incorrect manipulation of updating BIOS to avoid any claims from end-users.

### Before You Begin:

Before you start updating BIOS with the Q-Flash™ utility, please follow the steps below first.

1. Download the latest BIOS for your motherboard from Gigabyte's website.
2. Extract the BIOS file downloaded and save the BIOS file (the one with model name.Fxx. For example, 8KNXPU.Fba) to a floppy disk.
3. Reboot your PC and press **Del** to enter BIOS menu.

The BIOS upgrading guides below are separated into two parts.

If your motherboard has dual-BIOS, please refer to **Part One**.

If your motherboard has single-BIOS, please refer to **Part Two**.

### Part One:

#### Updating BIOS with Q-Flash™ Utility on Dual BIOS Motherboards.

Some of Gigabyte motherboards are equipped with dual BIOS. In the BIOS menu of the motherboards supporting Q-Flash and Dual BIOS, the Q-Flash utility and Dual BIOS utility are combined in the same screen. This section only deals with how to use Q-Flash utility.

**In the following sections, we take GA-8KNXP Ultra as the example to guide you how to flash BIOS from an older version to the latest version. For example, from Fa3 to Fba.**

The BIOS file is Fa3  
before updating

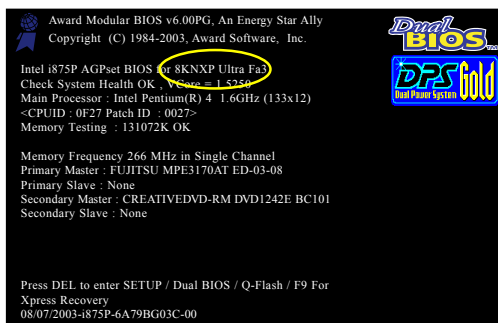

### Entering the Q-Flash™ utility:

Step1: To use Q-Flash utility, you must press **Del** in the boot screen to enter BIOS menu.

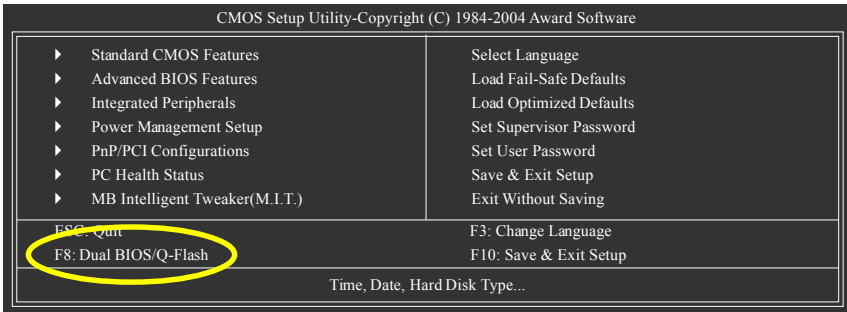

Step 2: Press **F8** button on your keyboard and then **Y** button to enter the Dual BIOS/Q-Flash utility.

### Exploring the Q-Flash™ / Dual BIOS utility screen

The Q-Flash / Dual BIOS utility screen consists of the following key components.

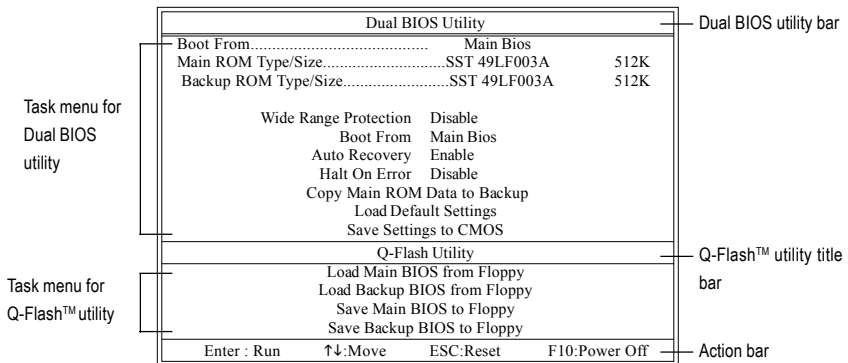

#### Task menu for Dual BIOS utility:

Contains the names of eight tasks and two item showing information about the BIOS ROM type. Blocking a task and pressing Enter key on your keyboard to enable execution of the task.

#### Task menu for Q-Flash utility:

Contains the names of four tasks. Blocking a task and pressing Enter key on your keyboard to enable execution of the task.

#### Action bar:

Contains the names of four actions needed to operate the Q-Flash/Dual BIOS utility. Pressing the buttons mentioned on your keyboards to perform these actions.

### Using the Q-Flash™ utility:

This section tells you how to update BIOS using the Q-Flash utility. As described in the "Before you begin" section above, you must prepare a floppy disk having the BIOS file for your motherboard and insert it to your computer. If you have already put the floppy disk into your system and have entered the Q-Flash utility, please follow the steps below to flash BIOS.

#### Steps:

1. Press arrow buttons on your keyboard to move the light bar to "Load Main BIOS from Floppy" item in the Q-Flash menu and press Enter button.

Later, you will see a box pop up showing the BIOS files you previously downloaded to the floppy disk.



If you want to save the current BIOS for backup purpose, you can begin Step 1 with "Save Main BIOS to Floppy" item.

2. Move to the BIOS file you want to flash and press **Enter**.

**In this example, we only download one BIOS file to the floppy disk so only one BIOS file, 8KNXPU.Fba, is listed.**



Please confirm again you have the correct BIOS file for your motherboard.

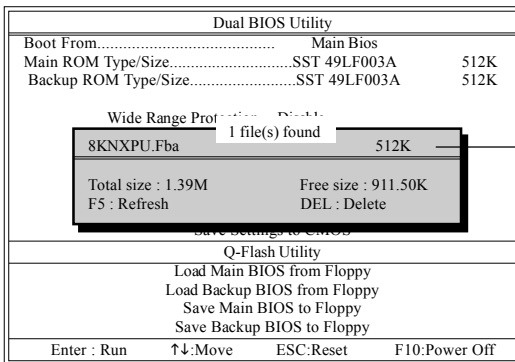

BIOS file in the floppy disk.

After pressing **Enter**, you'll then see the progress of reading the BIOS file from the floppy disk.

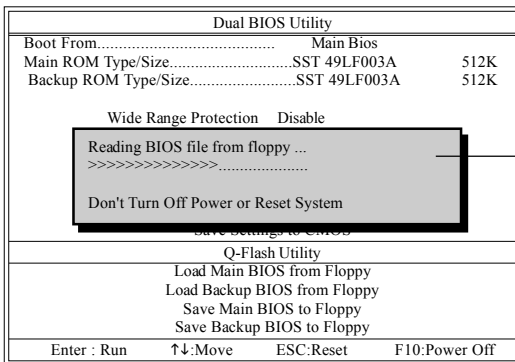

Do not turn off power or reset your system at this stage!!

After BIOS file is read, you'll see a confirmation dialog box asking you "Are you sure to update BIOS?"

3. Press Y button on your keyboard after you are sure to update BIOS.  
Then it will begin to update BIOS. The progress of updating BIOS will be displayed.



Please do not take out the floppy disk when it begins flashing BIOS.

4. Press any keys to return to the Q-Flash menu when the BIOS updating procedure is completed.

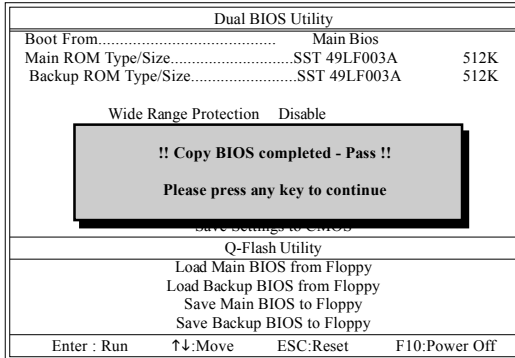

You can repeat Step 1 to 4 to flash the backup BIOS, too.

5. Press Esc and then Y button to exit the Q-Flash utility. The computer will restart automatically after you exit Q-Flash.

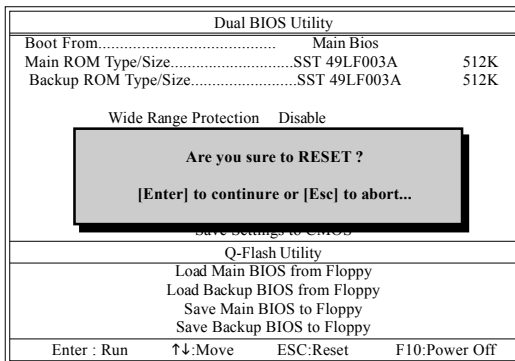

After system reboots, you may find the BIOS version on your boot screen becomes the one you flashed.

The BIOS file becomes Fba after updating.

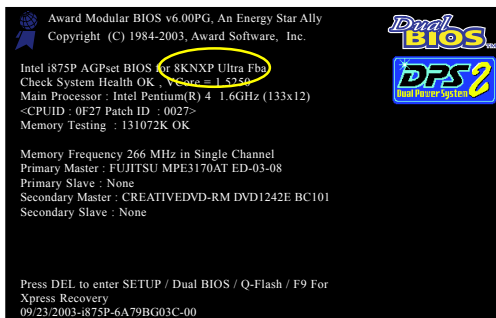

6. Press **Del** to enter BIOS menu after system reboots. When you are in BIOS menu, move to **Load Optimized Defaults** item and press **Enter** to load BIOS Optimized Defaults. Normally the system redetects all devices after BIOS has been upgraded. Therefore, we highly recommend reloading the BIOS defaults after BIOS has been upgraded.

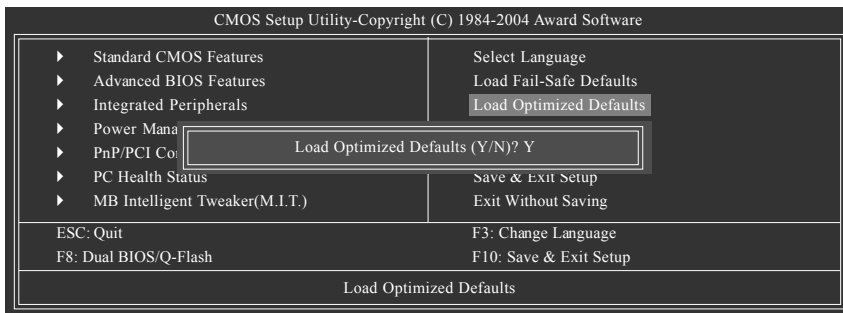

Press **Y** on your keyboard to load defaults.

7. Select **Save & Exit Setup** item to save the settings to CMOS and exit the BIOS menu. System will reboot after you exit the BIOS menu. The procedure is completed.

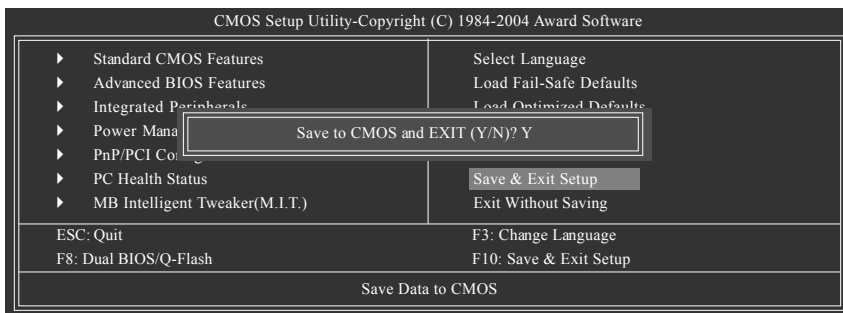

Press **Y** on your keyboard to save and exit.

## Part Two:

### Updating BIOS with Q-Flash™ Utility on Single-BIOS Motherboards.

This part guides users of single-BIOS motherboards how to update BIOS using the Q-Flash™ utility.

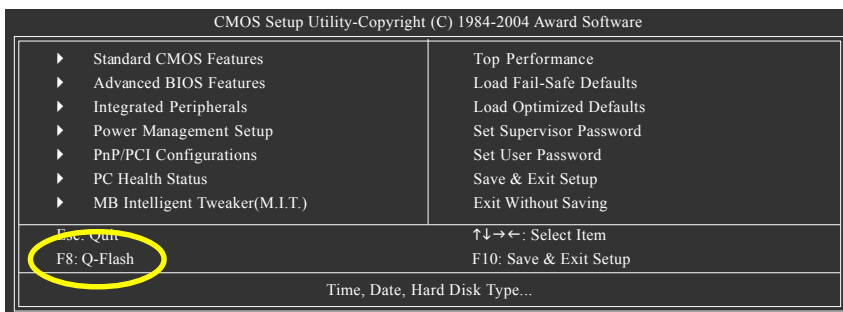



## Exploring the Q-Flash™ utility screen

The Q-Flash BIOS utility screen consists of the following key components.

Q-Flash Utility V1.30	
Flash Type/Size.....	SST 49LF003A 256K
Keep DMI Data	Enable
Update BIOS from Floppy	
Save BIOS to Floppy	
Enter : Run	↑↓:Move ESC:Reset F10:Power Off

Labels: Task menu for Q-Flash™ utility (points to the menu items), Q-Flash™ utility bar (top bar), Action bar (bottom bar)

### Task menu for Q-Flash utility:

Contains the names of three tasks. Blocking a task and pressing Enter key on your keyboard to enable execution of the task.

### Action bar:

Contains the names of four actions needed to operate the Q-Flash utility. Pressing the buttons mentioned on your keyboards to perform these actions.

### Using the Q-Flash™ utility:

This section tells you how to update BIOS using the Q-Flash utility. As described in the "Before you begin" section above, you must prepare a floppy disk having the BIOS file for your motherboard and insert it to your computer. If you have already put the floppy disk into your system and have entered the Q-Flash utility, please follow the steps below to flash BIOS.

#### Steps:

1. Press arrow buttons on your keyboard to move the light bar to "Update BIOS from Floppy" item in the Q-Flash menu and press Enter button.

Later, you will see a box pop up showing the BIOS files you previously downloaded to the floppy disk.



If you want to save the current BIOS for backup purpose, you can begin Step 1 with "Save BIOS to Floppy" item.

2. Move to the BIOS file you want to flash and press Enter.

**In this example, we only download one BIOS file to the floppy disk so only one BIOS file, 8GE800.F4, is listed.**



Please confirm again you have the correct BIOS file for your motherboard.

Q-Flash Utility V1.30	
Flash Type/Size.....	SST 49LF003A 256K
8GE800.F4	1 file(s) found 256K
Total size : 1.39M	Free size : 1.14M
F5 : Refresh	DEL : Delete
Enter	Power Off

BIOS file in the floppy disk.

Q-Flash Utility V1.30	
Flash Type/Size.....	SST 49LF003A 256K
Reading BIOS file from floppy ...	
>>>>>>>>>>>>>>>>>>>>>>>>>>>>	
Don't Turn Off Power or Reset System	
Enter	Power Off

CAUTION Do not turn off power or reset your system at this stage!!

After BIOS file is read, you'll see a confirmation dialog box asking you "Are you sure to update BIOS?"



Please do not take out the floppy disk when it begins flashing BIOS.

- Press Y button on your keyboard after you are sure to update BIOS.  
Then it will begin to update BIOS. The progress of updating BIOS will be shown at the same time.

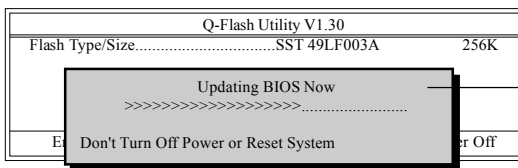

Do not turn off power or reset your system at this stage!!

- Press any keys to return to the Q-Flash menu when the BIOS updating procedure is completed.

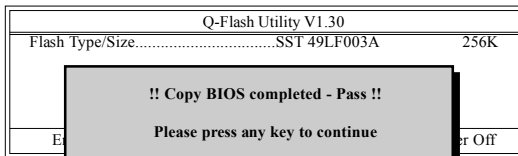

- Press Esc and then Y button to exit the Q-Flash utility. The computer will restart automatically after you exit Q-Flash.

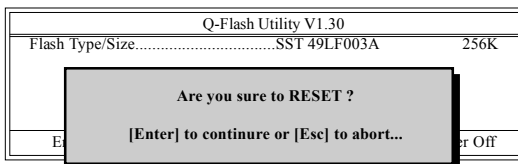

After system reboots, you may find the BIOS version on your boot screen becomes the one you flashed.

The BIOS file becomes F4 after updating

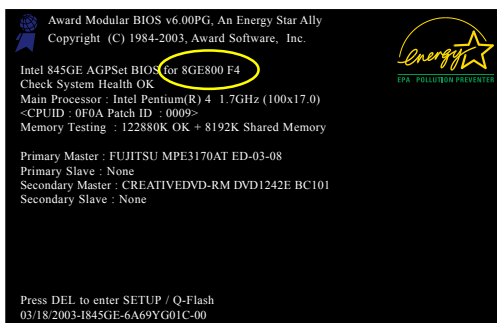

- Press Del to enter BIOS menu after system reboots and load BIOS optimized defaults. See how to load BIOS optimized defaults, please kindly refer to Step 6 to 7 in **Part One**.

**Congratulation!! You have updated BIOS successfully!!**

## Method 2 : @BIOS™ Utility

If you do not have a DOS startup disk, we recommend that you use the new @BIOS utility. @BIOS allows users to update their BIOS under Windows. Just select the desired @BIOS server to download the latest version of BIOS.

Fig 1. Installing the @BIOS utility

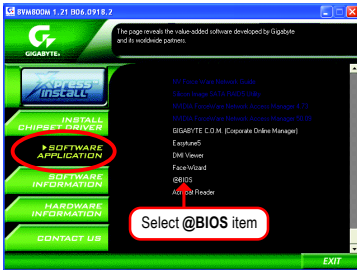

Fig 2. Installation Complete and Run @BIOS

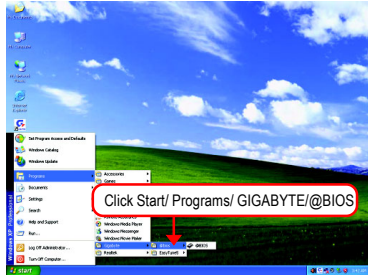

Fig 3. The @BIOS Utility

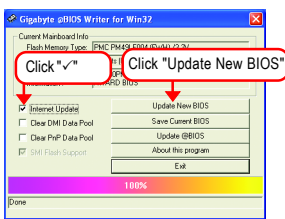

Fig 4. Select the desired @BIOS server



## 1. Methods and steps:

### I. Update BIOS through Internet

- a. Click "Internet Update" icon
- b. Click "Update New BIOS" icon
- c. Select @BIOS™ sever
- d. Select the exact model name on your motherboard
- e. System will automatically download and update the BIOS.

### II. Update BIOS NOT through Internet:

- a. Do not click "Internet Update" icon
- b. Click "Update New BIOS"
- c. Please select "All Files" in dialog box while opening the old file.
- d. Please search for BIOS unzip file, downloading from internet or any other methods (such as: VM800PMC.F1).
- e. Complete update process following the instruction.

### III. Save BIOS

In the very beginning, there is "Save Current BIOS" icon shown in dialog box. It means to save the current BIOS version.

### IV. Check out supported motherboard and Flash ROM:

In the very beginning, there is "About this program" icon shown in dialog box. It can help you check out which kind of motherboard and which brand of Flash ROM are supported.

## 2. Note:

- I. In method I, if it shows two or more motherboard's model names to be selected, please make sure your motherboard's model name again. Selecting wrong model name will cause the system unbooted.
- II. In method II, be sure that motherboard's model name in BIOS unzip file are the same as your motherboard's. Otherwise, your system won't boot.
- III. In method I, if the BIOS file you need cannot be found in @BIOS™ server, please go onto Gigabyte's web site for downloading and updating it according to method II.
- IV. Please note that any interruption during updating will cause system unbooted.
- V. Do not use @BIOS and C.O.M. (Corporate Online Management) at the same time.

## 4-1-4 Configuring SATA Hard Drive(s)

To configure SATA hard drive(s), follow the steps below:

- (1) Install SATA hard drive(s) in your system.
- (2) Configure SATA controller mode and boot sequence in BIOS Setup.
- (3) Configure RAID set in RAID BIOS.<sup>(Note)</sup>
- (4) Make a floppy disk containing the SATA controller driver.<sup>(Note)</sup>
- (5) Install the SATA controller driver during OS installation.<sup>(Note)</sup>

### Before you begin

Please prepare:

- (a) Two SATA hard drives (to ensure optimal performance, it is recommended that you use two hard drives with identical model and capacity). If you do not want to create RAID with the SATA controller, you may prepare only one hard drive.
- (b) An empty formatted floppy disk.
- (c) Windows XP/2000 setup disk.
- (d) Driver CD for your motherboard.

### (1) Install SATA hard drive(s) in your system

Attach one end of the SATA signal cable to the rear of the SATA hard drive and the other end to available SATA port(s) on the motherboard. If there are more than one SATA controller on your motherboard, you may refer to the motherboard user's manual to identify the SATA controller for the connector. Then connect the power connector from your power supply to the hard drive.

(Note) Skip this step if you do not want to create RAID array on the SATA controller.

## (2) Configuring SATA controller mode and boot sequence in BIOS Setup

You have to make sure whether the SATA controller is configured correctly in system BIOS Setup and set BIOS boot sequence for the SATA hard drive(s).

Step 1:

Turn on your computer and press Del to enter BIOS Setup during POST (Power-On Self Test). If you want to create RAID, select **SATA Mode** under the **Integrated Peripherals** menu (Figure 1) and set this item to **RAID (IDE by default)**. Set **SATA Mode** to **IDE** if you do not want to create RAID.

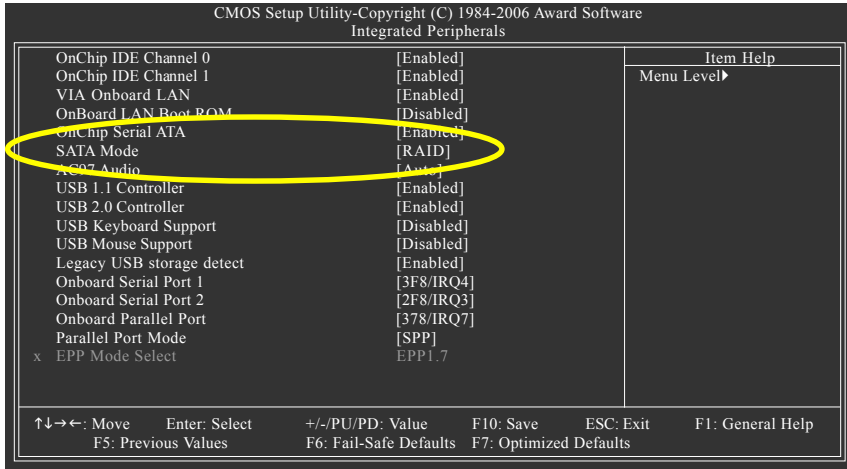

Figure 1



**NOTE** The BIOS Setup menus described in this section may not show the exact settings for your motherboard. The actual BIOS Setup menu options you will see shall depend on the motherboard you have and the BIOS version.

Step 2:

Set **First Boot Device** under the **Advanced BIOS Features** menu to **CDROM** to boot from CD-ROM after system restarts (Figure 2).

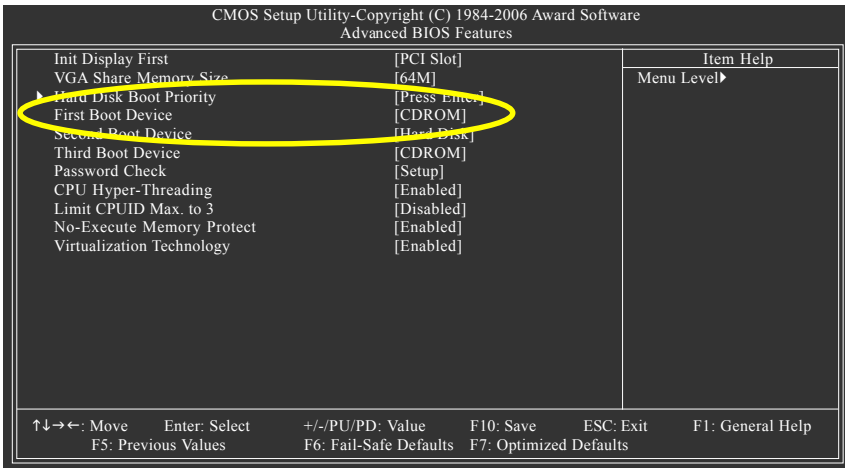

Figure 2

Step 3:

Save and exit BIOS Setup.

### (3) Configuring RAID set in RAID BIOS

Enter the RAID BIOS setup utility to configure a RAID array. Skip this step and proceed to Section 4 if you do not want to create RAID.

Step 1:

After the POST memory test begins and before the operating system boot begins, the following information will appear on screen (Figure 3). Press the TAB key to enter the **VT8237 Serial ATA RAID BIOS** configuration utility.

```
VIA Technologies, Inc. VIA VT8237 Serial ATA RAID BIOS Setting Utility V4.97
Copyright (C) VIA Technologies, Inc. All Right reserved.
```

```
Scan Devices, Please wait...
Press <Tab> key into User Window!
Serial_Ch0 Master : ST3120026AS
Serial_Ch1 Master : ST3120026AS
```

Figure 3

Step 2:

In the **VT8237 SATA RAID BIOS** utility screen (Figure 4), you can use the UP or DOWN ARROW key to highlight through choices. Highlight an item that you want to execute and press ENTER.

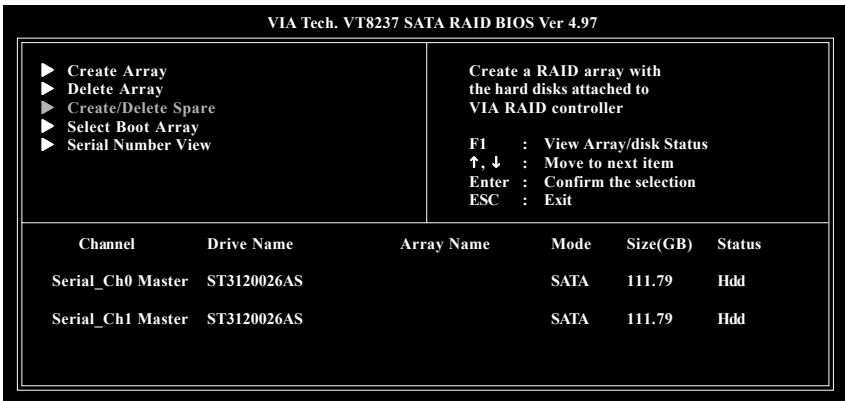

Figure 4



### A. Create Array:

In Main Menu, select **Create Array** and press ENTER, a screen similar to Figure 5 below will appear.

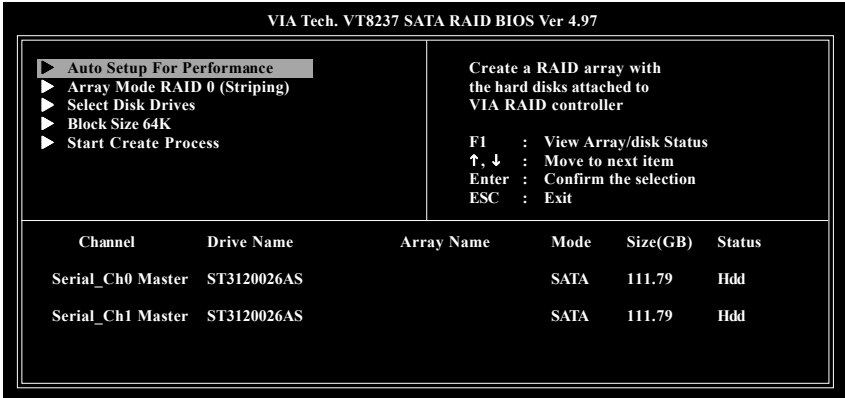

Figure 5

The first step to create a RAID array is to set the RAID mode. Select **Array Mode** and press ENTER. And the RAID mode selection menu will appear (Figure 6). The supported RAID modes include **RAID 0 for performance**, **RAID 1 for data protection**, and **RAID SPAN for capacity**. Use the UP or DOWN ARROW key to select a RAID mode.

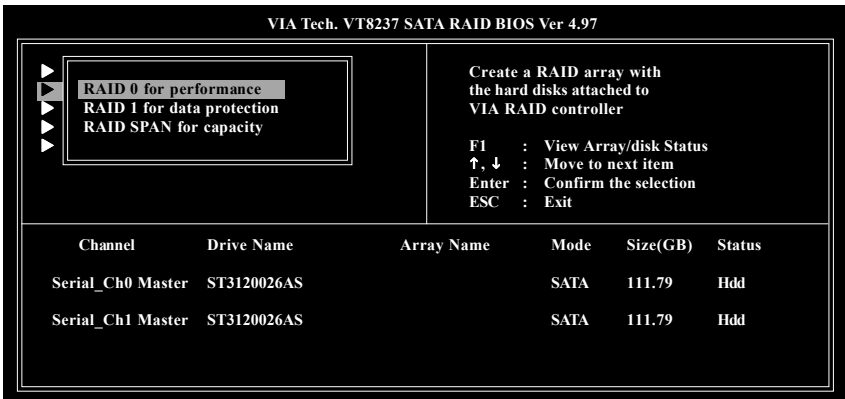

Figure 6

After selecting a RAID mode, you must decide whether you want the RAID array to be configured automatically or manually.

**Auto Setup** allows BIOS to assign the hard drives and create arrays automatically, but it does not duplicate the mirroring drives even if user selects **Create and duplicate for RAID 1**. It is recommended all hard drives are new ones when you want to create an array.

**Select Disk Drives** lets users select the array drives by their requirements. Select the **Select Disk Drives** item and press ENTER, use the ARROW keys to select the target hard drive(s). The selected hard drives will be marked with an asterisk (Figure 7).

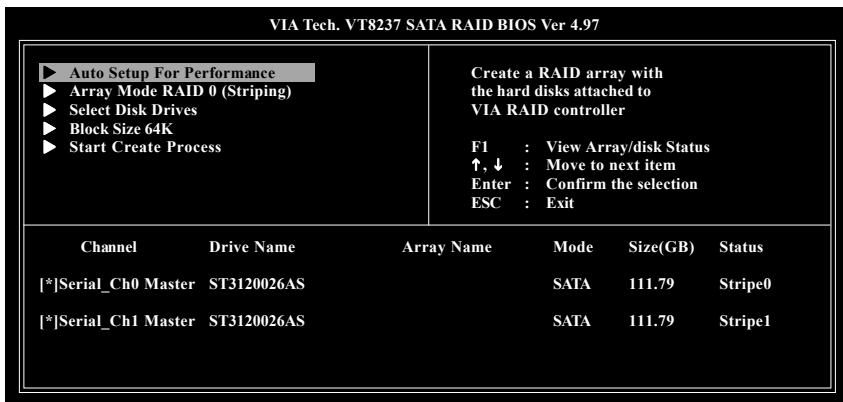

Figure 7

If you select to create RAID 0 array manually, you can specify the block size. Use the UP or DOWN ARROW keys to select **Block Size** and press ENTER. Select the block size from the popup menu. The block size can be set between 4KB to 64KB (Figure 8).

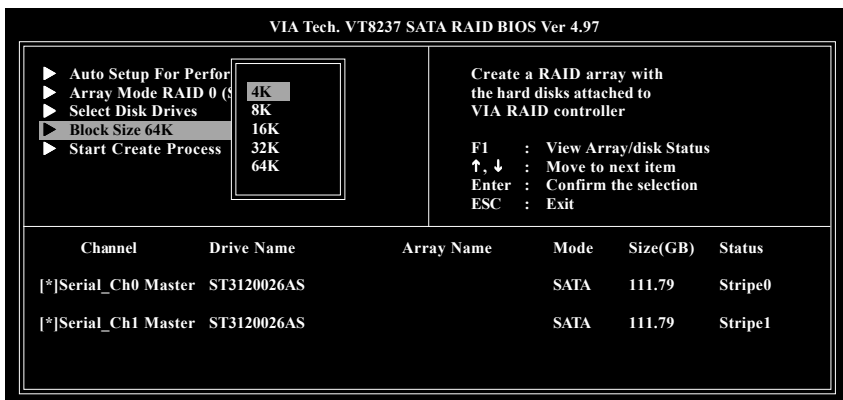

Figure 8

Next, use the ARROW keys to select **Start Create Process** and press ENTER. The prompt "The data on the selected disks will be destroyed. Continue? (Y/N)" will appear. Press Y to confirm or N to abort.

**Important** All existing contents in the hard drive will be destroyed after the array creation.

## B. Delete Array:

If you want to delete an existing array, select **Delete Array** in Main Menu and press ENTER. The channel column will be activated. Select the member of an array that is to be deleted and press ENTER. A warning message will show up, press Y to confirm or press N to cancel (Figure 9).

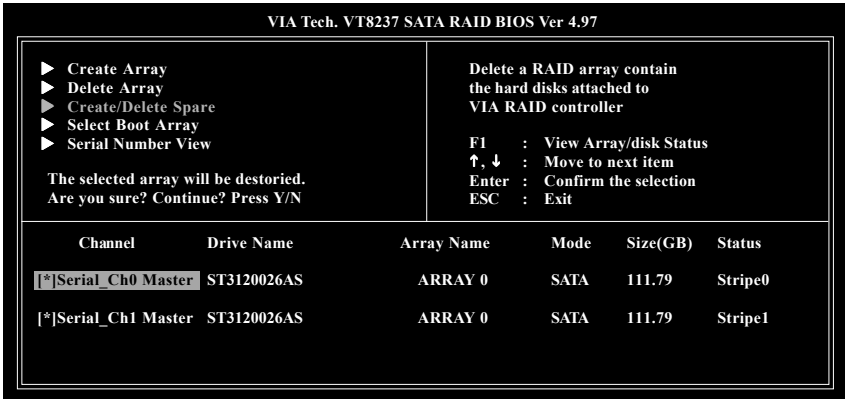

Figure 9

Deleting a disk array will destroy all the data on the disk array except for RAID 1 array(s). When a RAID 1 array is deleted, the data on the two hard drives will be reserved and the two hard drives will become two normal drives.

## C. Select Boot Array:

You can select a disk array as boot device if you want to boot operating system from an array. Boot disk array cannot be selected if the operating system does not boot from the disk array. Highlight the **Select Boot Array** item in Main Menu; press ENTER and the channel column will be activated. Then highlight the target disk array and press ENTER. Press ESC to go back to Main Menu. If you want to cancel the boot array setting, select the disk array that has an asterisk and press ENTER, its boot setting will be canceled (Figure 10).

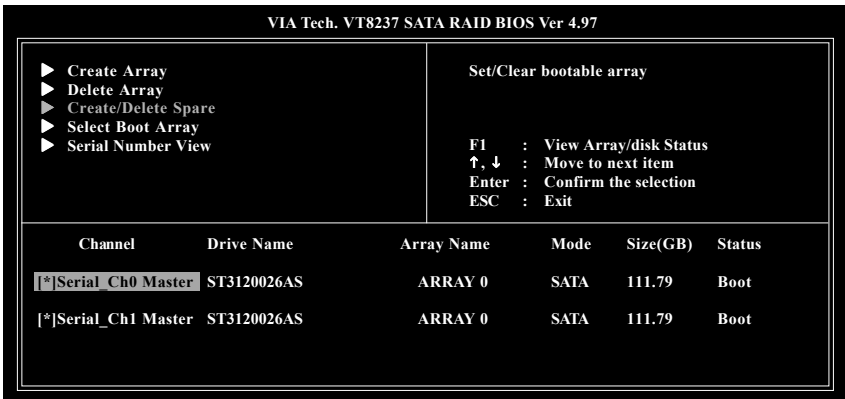

Figure 10

#### D. Serial Number View:

Highlight **Serial Number View** and press ENTER. Use the ARROW keys to select a drive, and the selected drive's serial number can be viewed in the last line. The serial number is assigned by the disk drive manufacturer (Figure 11).

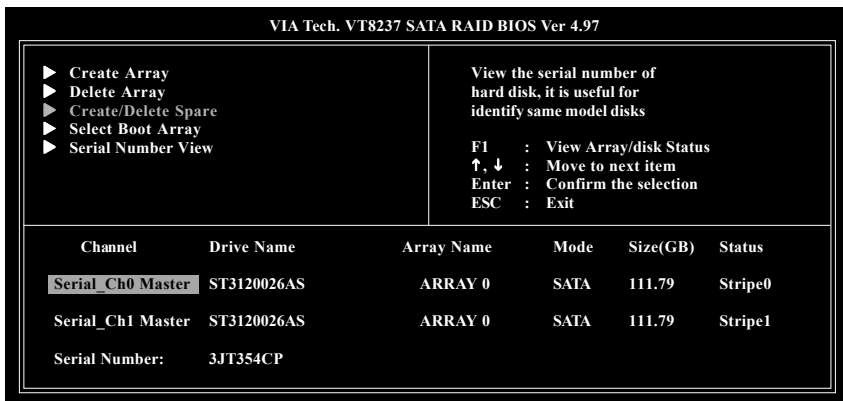

Figure 11

#### E. View Array Status:

Press F1 to show the array status on the lower screen. If there are no disk arrays then nothing will be displayed on the screen (Figure 12).

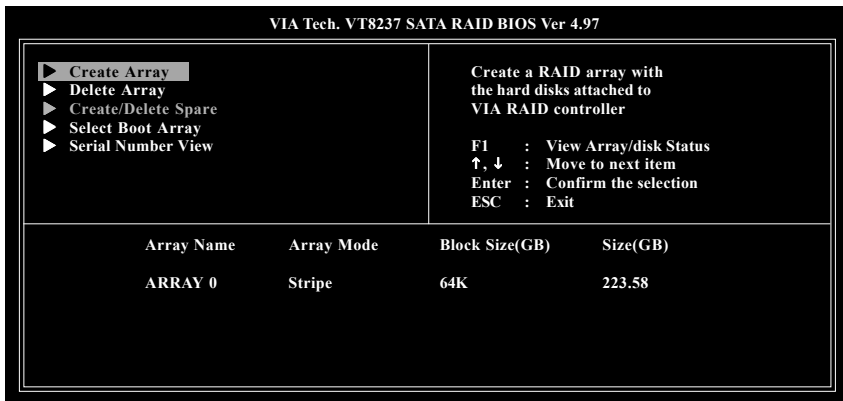

Figure 12

## (4) Making a SATA Driver Disk

To install operating system onto a serial ATA hard disk successfully, you need to install the SATA controller driver during OS installation. Without the driver, the hard disk may not be recognized during the Windows setup process. First of all, copy the driver for the SATA controller from the motherboard driver CD-ROM to a floppy disk. See the instructions below about how to copy the driver in MS-DOS mode<sup>(Note)</sup>. Prepare a startup disk that has CD-ROM support and a blank formatted floppy disk.

Step 1: Insert the prepared startup disk and motherboard driver CD-ROM in your system. Boot from the startup disk. Once at the A:\> prompt, change to the CD-ROM drive (example: D:\>). At the D:\> prompt, type the following two commands. Press ENTER after each command (Figure 13):

```
cd bootdrv
menu
```

```
D:\BOOTDR> cd bootdrv
D:\BOOTDR> menu
```

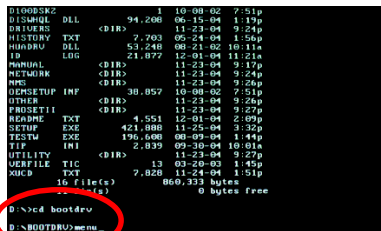

Figure 13

```
1) Intel IAH RAID
2) GIGABYTE
3) S11R03E
4) S11R01D
5) SCS1
6) Promise 20276 ATA
7) Promise 20276 RAID
8) Promise 20265 ATA
9) Promise 20265 ATA(XP)
A) Promise 20265 RAID
B) Promise 20265 RAID(XP)
C) VIA 8237 Series ATA
D) S1114
E) S1114 Raid
0) Exit
```

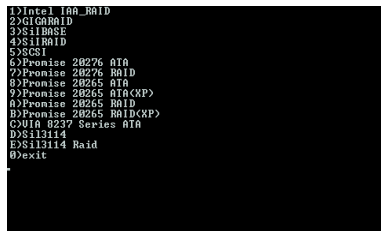

Figure 14

Step 2: When the controller menu (Figure 14) appears, remove the startup disk and insert the blank formatted disk. Select the controller driver by pressing the corresponding letter from the menu.

For example, from the menu in Figure 14, press C to select **VIA 8237 Series ATA** for Windows operating system. Your system will then automatically zip and transfer this driver file to the floppy disk. Press 0 to exit when finished.

(Note) For users without a startup disk:

Use an alternative system and insert the GIGABYTE motherboard driver CD-ROM. From the CD-ROM drive folder, double click the **MENU.exe** file in the **BootDrv** folder (Figure 15). A command prompt window will open similar to that in Figure 14.

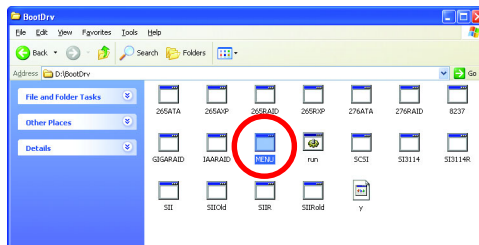

Figure 15

## (5) Installing SATA controller driver during OS installation

Now that you have prepared the SATA driver disk and configured BIOS settings, you are ready to install Windows 2000/XP onto your SATA hard drive with the SATA driver. The following is an example of Windows XP installation.

Step 1: Restart your system to boot from the Windows 2000/XP Setup disk and press F6 as soon as you see the "Press F6 if you need to install a 3rd party SCSI or RAID driver" message (Figure 16). After pressing F6, there will be a few moments of some files being loaded before you see the next screen.

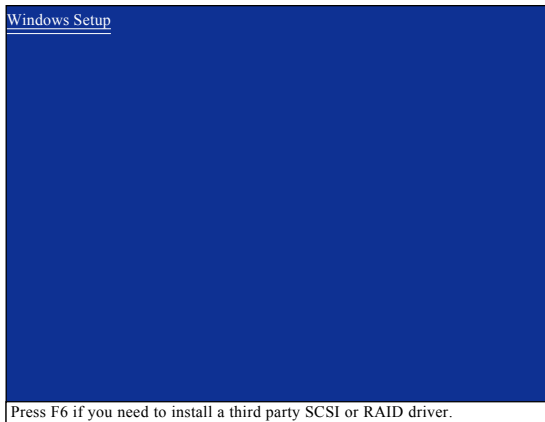

Figure 16

Step 2:

When a screen similar to that below appears, insert the floppy disk containing the SATA driver and press S (Figure 17).

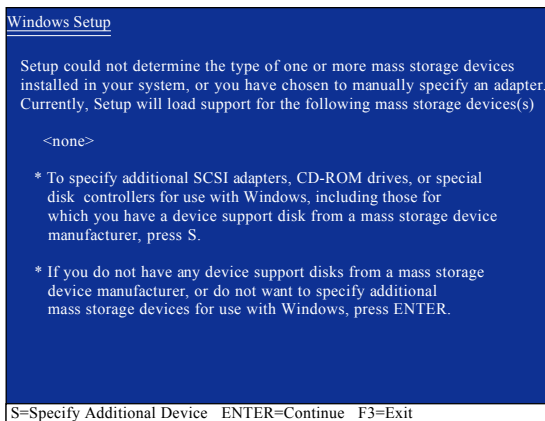

Figure 17

**Step 3:**

If Setup correctly recognizes the driver in the floppy disk, a controller menu similar to Figure 18 below will appear. If you want to install Windows XP, use the ARROW keys to select **VIA V-RAID Controller Series(Windows XP)** and press ENTER. Then it will begin to load the SATA driver from the floppy disk.

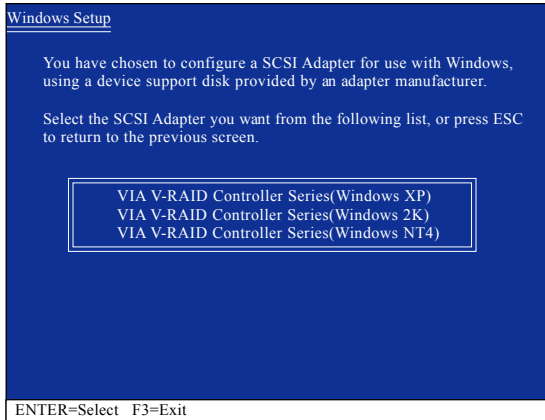

Figure 18



If a message appears saying one or some file(s) cannot be found, please check the floppy disk or copy the correct SATA driver again from the motherboard driver CD.

**Step 4:**

When the screen as shown below appears, press ENTER to continue the SATA driver installation from the floppy disk. The driver installation will be finished in about one minute.

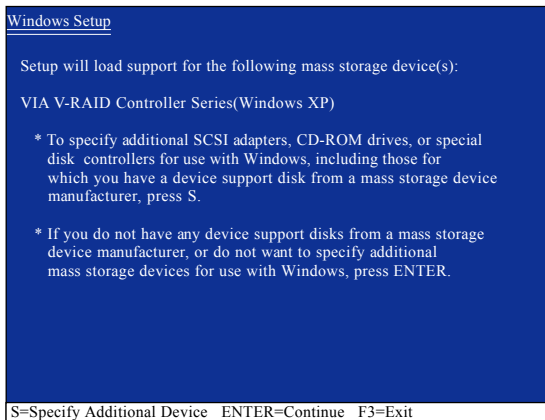

Figure 19

After the SATA controller driver installation is completed, you should see a screen as below. It indicates that you have installed the SATA controller driver successfully. You can proceed with the Windows 2000/XP installation.

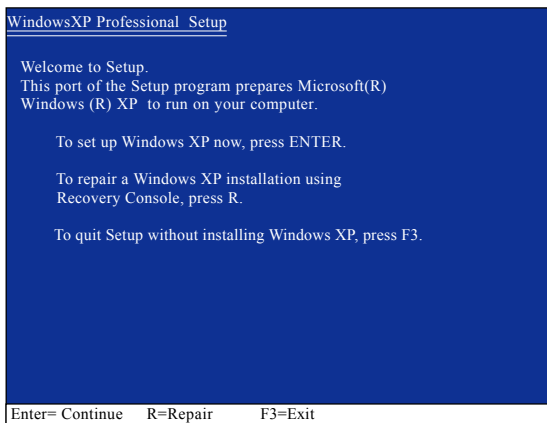

Figure 20

(Note: Each time you add a new hard drive to a RAID array, the RAID driver will have to be installed under Windows once for that hard drive. After that, the driver will not have to be installed.)



## 4-1-5 2 / 4 / 6 Channel Audio Function Introduction

### 2 Channel Audio Setup

We recommend that you use speakers with amplifier to get the best sound effect if the stereo output is applied.

#### STEP 1:

Connect the stereo speakers or earphone to "Line Out."

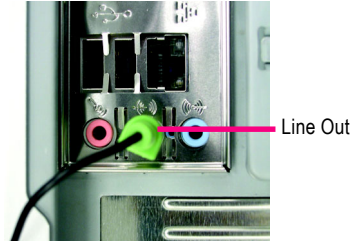

#### STEP 2:

After installing the audio driver, you'll find a VIA Audio Deck icon  on the lower right hand taskbar. Double-click the icon to open the Audio Control Panel.

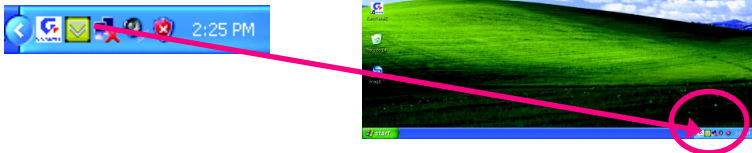

#### STEP 3:

In the Audio Control Panel, click the **Speaker** tab. In the left list, click **2 Channel** button. The 2-channel audio setup is completed.



## 4 Channel Analog Audio Output Mode

### STEP 1:

Connect the front channels to "Line Out,"  
the rear channels to "Line In."

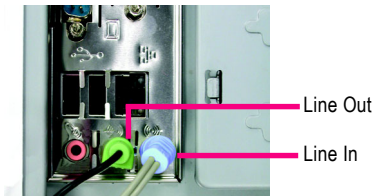

### STEP 2:

After installing the audio driver, you'll find a VIA  
Audio Deck icon  on the lower right hand taskbar.  
Double-click the icon to open the Audio Control  
Panel.

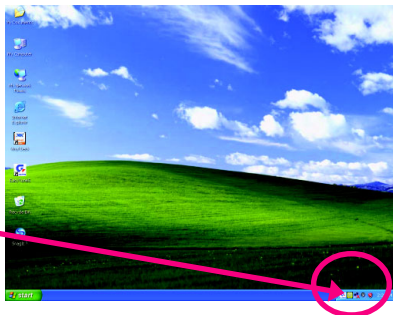

### STEP 3:

In the Audio Control Panel, click the **Speaker** tab  
and select the **4 Channel** check box.



When the **Environmental Modeling** is disable,  
the sound would be performed as stereo mode (2  
Channel output). Please select other settings (ex:  
**Living Room**) for 4 Channel output.

Select the **Enable Environmental  
Modeling** check box.



## Basic 6 Channel Analog Audio Output Mode

Use the back audio panel to connect the audio output without any additional module.

STEP 1:

Connect the front channels to "Line Out", the rear channels to "Line In", and the Center/Subwoofer channels to "MIC In".

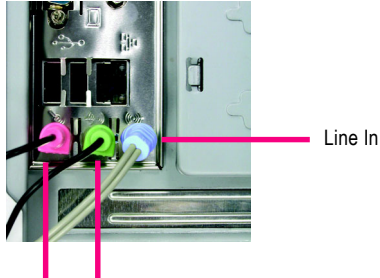

MIC In Line Out

STEP 2:

After installing the audio driver, you'll find a VIA Audio Deck icon on the lower right hand taskbar. Double-click the icon to open the Audio Control Panel.

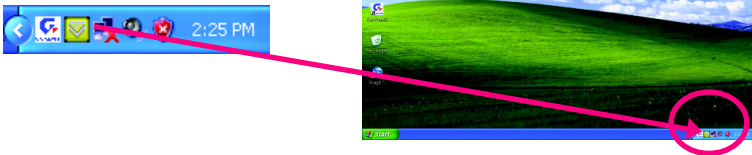

STEP 3:

In the Audio Control Panel, click the **Speaker** tab and select the **6 Channel** check box.



STEP 4:

In the Audio Control Panel, click the **Phone Jack** tab and select the **Enable Smart5.1 Plus (blue jack for side surround and red jack for center/LFE speakers output)** check box.

Enable Smart5.1 Plus (blue jack for side surround and red jack for center/LFE speakers output)



## Advanced 6 Channel Analog Audio Output Mode (using 6-Channel Audio Combo Kit , Optional Device):

**6-Channel Audio Combo Kit** provides S/PDIF output port (optical & coaxial) and SURROUND-Kit (Rear R/L & CEN /Subwoofer)

SURROUND-KIT access analog output to rear channels and Center/Subwoofer channels. It is the best solution if you need 6 channel output, Line In and MIC at the same time. "SURROUND-KIT" is included in the GIGABYTE unique "6-Channel Audio Combo Kit" as picture.

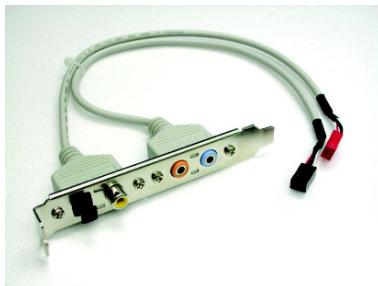

### STEP 1:

Secure the metal bracket of the "6-Channel Audio Combo Kit" to the chassis back panel with a screw.



### STEP 2:

Connect the "SURROUND-KIT" cable to the SUR\_CEN connector on the M/B.

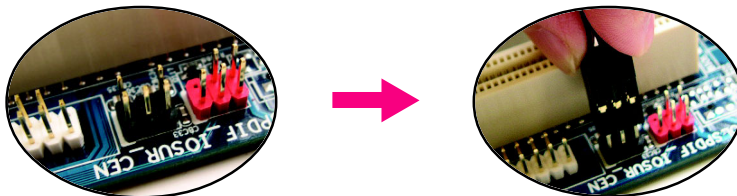

### STEP 3:

Connect the front channels to back audio panel's "Line Out", the rear channels to SURROUND-Kit's REAR R/L, and the Center/Subwoofer channels to SURROUND-Kit's SUB CENTER.

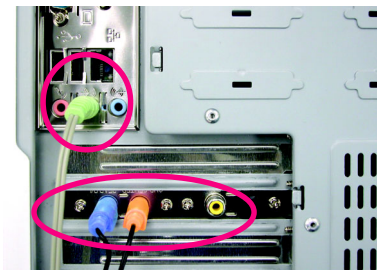

**STEP 4:**

After installing the audio driver, you'll find a SVIA Audio Deck icon  on the lower right hand taskbar. Double-click the icon to open the Audio Control Panel.

**STEP 5:**

In the Audio Control Panel, click the **Speaker** tab and select the **6 Channel** check box.

**STEP 6:**

In the Audio Control Panel, click the **Phone Jack** tab and do not select the **Enable Smart5.1 Plus (blue jack for side surround and red jack for center/LFE speakers output)** check box.

Enable Smart5.1 Plus (blue jack for side surround and red jack for center/LFE speakers output)

**Basic & Advanced 6 Channel Analog Audio Output Mode Notes:**

When the **Environmental Modeling** is disable, the sound would be performed as stereo mode (2 Channel output). Please select other settings (ex: **Living Room**) for 6 Channel output.

Select the **Enable Environmental Modeling** check box.



## 4-2 Troubleshooting

Below is a collection of general asked questions. To check general asked questions based on a specific motherboard model, please log on to GIGABYTE's website.

Question 1: I cannot see some options that were included in previous BIOS after updating BIOS. Why?

Answer: Some advanced options are hidden in new BIOS version. Please press Ctrl and F1 keys after entering BIOS menu and you will be able to see these options.

Questions 2: Why is the light of my keyboard/optical mouse still on after computer shuts down?

Answer: In some boards, a small amount of electricity is kept on standby after computer shuts down and that's why the light is still on.

Question 3: How do I clear CMOS?

Answer: If your board has a Clear CMOS jumper, please refer to the Clear CMOS steps in the manual. If your board doesn't have such jumper, you can take off the on-board battery to leak voltage to clear CMOS. Please refer to the steps below:

Steps:

1. Turn off power.
2. Disconnect the power cord from MB.
3. Take out the battery gently and put it aside for about 1 minute (Or you can use a metal object to connect the positive and negative pins in the battery holder to makethem short for 5 seconds).
4. Re-insert the battery to the battery holder.
5. Connect power cord to MB again and turn on power.
6. Press Del to enter BIOS and load Fail-Safe Defaults(or load Optimized Defaults).
7. Save changes and reboot the system.

Question 4: Why do I still get a weak sound after turning up the speaker to the maximum volume?

Answer: Please make sure the speaker you are using is equipped with an internal amplifier. If not, please change another speaker with power/amplifier and try again later.

Question 5: Sometimes I hear different continuous beeps from computer after system boots up. What do these beeps usually stand for?

Answer: The beep codes below may help you identify the possible computer problems. However, they are only for reference purposes. The situations might differ from case to case.

→ AWARD BIOS Beep Codes

1 short: System boots successfully

2 short: CMOS setting error

1 long 1 short: DRAM or M/B error

1 long 2 short: Monitor or display card error

1 long 3 short: Keyboard error

1 long 9 short: BIOS ROM error

Continuous long beeps: DRAM error

Continuous short beeps: Power error







---

---

---

---

---

---

---

---

---

---

---

---

---

---

---

---

---

---

---

---

---

---

---

---

---

---

---

---

---

---

---

---

---

---

---

---

---

---

---

---

---

---

---

---

---

---

---

---

---

---

---

---

---

---

---

---

---

---

---

---

---

---

---

---

---

---

---

---

---

---

---

---

---

---

---

---

---

---

---



---

---

---

---

---

---

---

---

---

---

---

---

---

---

---

---

---

---

---

---

---

---

---

---

---

---

---

---



## Contact Us

---

- **Taiwan (Headquarters)**

GIGA-BYTE TECHNOLOGY CO., LTD.

Address: No.6, Bau Chiang Road, Hsin-Tien,

Taipei 231, Taiwan

TEL: +886-2-8912-4888

FAX: +886-2-8912-4003

Tech. and Non-Tech. Support (Sales/Marketing) :

<http://ggts.gigabyte.com.tw>

WEB address (English): <http://www.gigabyte.com.tw>

WEB address (Chinese): <http://www.gigabyte.tw>

---

- **U.S.A.**

G.B.T. INC.

TEL: +1-626-854-9338

FAX: +1-626-854-9339

Tech. Support:

<http://rma.gigabyte-usa.com>

Web address: <http://www.gigabyte.us>

---

- **Mexico**

G.B.T Inc (USA)

Tel: +1-626-854-9338 x 215 (Soporte de habla hispano)

FAX: +1-626-854-9339

Correo: [soporte@gigabyte-usa.com](mailto:soporte@gigabyte-usa.com)

Tech. Support:

<http://rma.gigabyte-usa.com>

Web address: <http://www.gigabyte-latam.com>

---

- **Japan**

NIPPON GIGA-BYTE CORPORATION

WEB address : <http://www.gigabyte.co.jp>

---

- **Singapore**

GIGA-BYTE SINGAPORE PTE. LTD.

WEB address : <http://www.gigabyte.com.sg>

---



---

- **China**

NINGBO G.B.T. TECH. TRADING CO., LTD.

WEB address : <http://www.gigabyte.cn>

- **Shanghai**

TEL: +86-21-63410999

FAX: +86-21-63410100

- **Beijing**

TEL: +86-10-62102838

FAX: +86-10-62102848

- **Wuhan**

TEL: +86-27-87851061

FAX: +86-27-87851330

- **GuangZhou**

TEL: +86-20-87540700

FAX: +86-20-87544306 ext. 333

- **Chengdu**

TEL: +86-28-85236930

FAX: +86-28-85256822 ext. 814

- **Xian**

TEL: +86-29-85531943

FAX: +86-29-85539821

- **Shenyang**

TEL: +86-24-83992901

FAX: +86-24-83992909

---

- **India**

GIGABYTE TECHNOLOGY (INDIA) LIMITED

WEB address : <http://www.gigabyte.in>

---

- **Australia**

GIGABYTE TECHNOLOGY PTY. LTD.

WEB address : <http://www.gigabyte.com.au>

---

---

- **Germany**

G.B.T. TECHNOLOGY TRADING GMBH

WEB address : <http://www.gigabyte.de>

---

- **U.K.**

G.B.T. TECH. CO., LTD.

WEB address : <http://www.giga-byte.co.uk>

---

- **The Netherlands**

GIGA-BYTE TECHNOLOGY B.V.

WEB address : <http://www.giga-byte.nl>

---

- **France**

GIGABYTE TECHNOLOGY FRANCE

WEB address : <http://www.gigabyte.fr>

---

- **Italy**

WEB address : <http://www.giga-byte.it>

---

- **Spain**

GIGA-BYTE SPAIN

WEB address : <http://www.giga-byte.es>

---

- **Czech Republic**

Representative Office Of GIGA-BYTE Technology Co., Ltd.  
in CZECH REPUBLIC

WEB address : <http://www.gigabyte.cz>

---

- **Turkey**

Representative Office Of GIGA-BYTE Technology Co., Ltd.  
in TURKEY

WEB address : <http://www.gigabyte.com.tr>

---



---

- **Russia**

Moscow Representative Office Of GIGA-BYTE Technology Co., Ltd.

WEB address : <http://www.gigabyte.ru>

---

- **Latvia**

GIGA-BYTE Latvia

WEB address : <http://www.gigabyte.com.lv>

---

- **Poland**

Office of GIGA-BYTE TECHNOLOGY Co., Ltd. in POLAND

WEB address : <http://www.gigabyte.pl>

---

- **Ukraine**

WEB address : <http://www.gigabyte.kiev.ua>

---

- **Romania**

Representative Office Of GIGA-BYTE Technology Co., Ltd.  
in Romania

WEB address : <http://www.gigabyte.com.ro>

---

- **Serbia & Montenegro**

Representative Office Of GIGA-BYTE Technology Co., Ltd.  
in SERBIA & MONTENEGRO

WEB address : <http://www.gigabyte.co.yu>

---

- **GIGABYTE Global Service System**



To submit a technical or non-technical (Sales/ Marketing) question, please link to :  
<http://gts.gigabyte.com.tw>

Then select your language to enter the system.



关于符合中国《电子信息产品污染控制管理办法》的声明  
 Management Methods on Control of Pollution from Electronic Information Products  
 (China RoHS Declaration)

产品中有毒有害物质或元素的名称及含量  
 Hazardous Substances Table

部件名称 (Parts)	有毒有害物质或元素 (Hazardous Substances)					
	铅 (Pb)	汞 (Hg)	镉 (Cd)	六价铬 (Cr (VI))	多溴联苯 (PBB)	多溴二苯醚 (PBDE)
PCB板 PCB	○	○	○	○	○	○
结构件及风扇 Mechanical parts and Fan	×	○	○	○	○	○
芯片及其他主动零件 Chip and other Active components	×	○	○	○	○	○
连接器 Connectors	×	○	○	○	○	○
被动电子元件 Passive Components	×	○	○	○	○	○
线材 Cables	○	○	○	○	○	○
焊接金属 Soldering metal	○	○	○	○	○	○
助焊剂, 散热膏, 标签及其他耗材 Flux, Solder Paste, Label and other Consumable Materials	○	○	○	○	○	○
○: 表示该有毒有害物质在该部件所有均质材料中的含量均在SJ/T11363-2006标准规定的限量要求以下。 Indicates that this hazardous substance contained in all homogenous materials of this part is below the limit requirement SJ/T 11363-2006						
×: 表示该有毒有害物质至少在该部件的某一均质材料中的含量超出SJ/T11363-2006标准规定的限量要求。 Indicates that this hazardous substance contained in at least one of the homogenous materials of this part is above the limit requirement in SJ/T 11363-2006						
对销售之日的所发售产品, 本表显示我公司供应链的电子信息产品可能包含这些物质。注意: 在所售产品中可能会也可能不会含有所有列出的部件。 This table shows where these substances may be found in the supply chain of our electronic information products, as of the date of the sale of the enclosed products. Note that some of the component types listed above may or may not be a part of the enclosed product.						



## Free Manuals Download Website

<http://myh66.com>

<http://usermanuals.us>

<http://www.somanuals.com>

<http://www.4manuals.cc>

<http://www.manual-lib.com>

<http://www.404manual.com>

<http://www.luxmanual.com>

<http://aubethermostatmanual.com>

Golf course search by state

<http://golfingnear.com>

Email search by domain

<http://emailbydomain.com>

Auto manuals search

<http://auto.somanuals.com>

TV manuals search

<http://tv.somanuals.com>