

DENON

WIRELESS NETWORK MUSIC SYSTEM

S-32

Owner's Manual

Bedienungsanleitung

Manuel de l'Utilisateur

Manuale delle istruzioni

Manual del usuario

Gebruiksaanwijzing

Bruksanvisning

SAFETY PRECAUTIONS

CAUTION
RISK OF ELECTRIC SHOCK
DO NOT OPEN

CAUTION:
TO REDUCE THE RISK OF ELECTRIC SHOCK, DO NOT REMOVE COVER (OR BACK). NO USER-SERVICEABLE PARTS INSIDE. REFER SERVICING TO QUALIFIED SERVICE PERSONNEL.

The lightning flash with arrowhead symbol, within an equilateral triangle, is intended to alert the user to the presence of uninsulated "dangerous voltage" within the product's enclosure that may be of sufficient magnitude to constitute a risk of electric shock to persons.

The exclamation point within an equilateral triangle is intended to alert the user to the presence of important operating and maintenance (servicing) instructions in the literature accompanying the appliance.

WARNING:
TO REDUCE THE RISK OF FIRE OR ELECTRIC SHOCK, DO NOT EXPOSE THIS APPLIANCE TO RAIN OR MOISTURE.

CE 0413 **R&TTE Directive 1999/5/EC**

This product may be operated in the following countries;

AT	BE	CZ	DK	FI
FR	DE	GR	HU	IE
IT	NL	PL	PT	SK
ES	SE	GB	NO	CH

- DECLARATION OF CONFORMITY**
 Hereby, D&M Holdings Inc., Denon Brand Company declares that this product S-32 is in compliance with the essential requirements and other relevant provisions of Directive 1999/5/EC, in conformity with the following standards:
 EN60065, EN55013, EN55020, EN55022, EN55024, EN61000-3-2, EN61000-3-3, EN300328, EN301489-01, EN301489-17 and EN50385
 The declaration of conformity may be consulted to our European representative, DENON EUROPE.
- ÜBEREINSTIMMUNGSERKLÄRUNG**
 Hiermit erklärt D&M Holdings Inc., Denon Brand Company, dass sich das Gerät S-32 in Übereinstimmung mit den grundlegenden Anforderungen und den übrigen einschlägigen Bestimmungen der Richtlinie 1999/5/EG befindet, den folgenden Standards entspricht:
 EN60065, EN55013, EN55020, EN55022, EN55024, EN61000-3-2, EN61000-3-3, EN300328, EN301489-01, EN301489-17 und EN50385
 Wenden Sie sich bei Fragen zur Konformitätserklärung an unseren europäischen Vertreter, DENON EUROPE.
- DECLARATION DE CONFORMITE**
 Par la présente, D&M Holdings Inc., Denon Brand Company déclare que l'appareil S-32 est conforme aux exigences essentielles et aux autres dispositions pertinentes de la directive 1999/5/CE, e conforme alle seguenti normative:
 EN60065, EN55013, EN55020, EN55022, EN55024, EN61000-3-2, EN61000-3-3, EN300328, EN301489-01, EN301489-17 e EN50385.
 La déclaration de conformité pourra être consultée auprès de notre représentant en Europe, DENON EUROPE.
- DICHIARAZIONE DI CONFORMITÀ**
 Con la presente D&M Holdings Inc., Denon Brand Company dichiara che questo S-32 è con-forme ai requisiti essenziali ed alle altre disposizioni pertinenti stabilite dalla direttiva 1999/5/CE, e conforme alle seguenti normative:
 EN60065, EN55013, EN55020, EN55022, EN55024, EN61000-3-2, EN61000-3-3, EN300328, EN301489-01, EN301489-17 e EN50385.
 La dichiarazione di conformità può essere consultata presso il nostro rappresentante europeo, DENON EUROPE.
 QUESTO PRODOTTO E' CONFORME
 AL D.M. 28/08/95 N. 548
- DECLARACIÓN DE CONFORMIDAD**
 Por la presente, D&M Holdings Inc., Denon Brand Company, declara que este S-32 cumple con los requisitos esenciales y otras exigencias relevantes de la Directiva 1999/5/EC, esta conforme con los siguientes estándares:
 EN60065, EN55013, EN55020, EN55022, EN55024, EN61000-3-2, EN61000-3-3, EN300328, EN301489-01, EN301489-17 y EN50385.
 Puede consultar a nuestro representante europeo, DENON EUROPE, acerca de la declaración de conformidad.
- EENVORMIGHEIDSVERKLARING**
 Hierbij verklaart D&M Holdings Inc., Denon Brand Company dat het toestel S-32 in overeenstemming is met de essentiële eisen en de andere relevante bepalingen van richtlijn 1999/5/EG, in overeenstemming is met de volgende normen:
 EN60065, EN55013, EN55020, EN55022, EN55024, EN61000-3-2, EN61000-3-3, EN300328, EN301489-01, EN301489-17 en EN50385.
 De eenvormigheidsverklaring mag worden geconsulteerd aan onze Europese vertegenwoordiger, DENON EUROPE.

DENON EUROPE
 Division of D&M Germany GmbH
 An der Landwehr 19, Nettetal,
 D-41334 Germany

- ÖVERENSSTÄMMELSESI NTY G**
 Denna utrustning är i överensstämmelse med de väsentliga kraven och andra relevanta bestämmelser i Direktiv 1999/5/EC, uppfyller följande standarder:
 EN60065, EN55013, EN55020, EN55022, EN55024, EN61000-3-2, EN61000-3-3, EN300328, EN301489-01, EN301489-17 och EN50385.
 EU-konformitetsintyget kan på begäran fås från DENON EUROPE, vår representant i Europa.

CAUTION:
 To completely disconnect this product from the mains, disconnect the plug from the wall socket outlet.
 The mains plug is used to completely interrupt the power supply to the unit and must be within easy access by the user.

VORSICHT:
 Um dieses Gerät vollständig von der Stromversorgung abzutrennen, ziehen Sie bitte den Stecker aus der Wandsteckdose.
 Der Netzstecker wird verwendet, um die Stromversorgung zum Gerät völlig zu unterbrechen; er muss für den Benutzer gut und einfach zu erreichen sein.

PRECAUTION:
 Pour déconnecter complètement ce produit du courant secteur, débranchez la prise de la prise murale.
 La prise secteur est utilisée pour couper complètement l'alimentation de l'appareil et l'utilisateur doit pouvoir y accéder facilement.







ATTENZIONE:
 Per scollegare completamente questo prodotto dalla rete di alimentazione elettrica, scollegare la spina dalla relativa presa a muro.
 La spina di rete viene utilizzata per interrompere completamente l'alimentazione all'unità e deve essere facilmente accessibile all'utente.

PRECAUCIÓN:
 Para desconectar completamente este producto de la alimentación eléctrica, desconecte el enchufe del enchufe de la pared.
 El enchufe de la alimentación eléctrica se utiliza para interrumpir por completo el suministro de alimentación eléctrica a la unidad y debe de encontrarse en un lugar al que el usuario tenga fácil acceso.

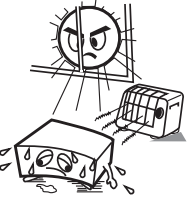
WAARSCHUWING:
 Om de voeding van dit product volledig te onderbreken moet de stekker uit het stopcontact worden getrokken.
 De netstekker wordt gebruikt om de stroomtoevoer naar het toestel volledig te onderbreken en moet voor de gebruiker gemakkelijk bereikbaar zijn.

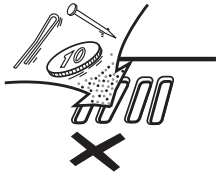
FÖRSIKTIHETSMÅTT:
 Koppla loss stickproppen från eluttaget för att helt skilja produkten från nätet.
 Stickproppen används för att helt bryta strömförsörjningen till apparaten, och den måste vara lättillgänglig för användaren.

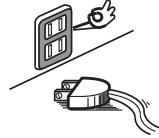
NOTE ON USE / HINWEISE ZUM GEBRAUCH / OBSERVATIONS RELATIVES A L'UTILISATION / NOTE SULL'USO / NOTAS SOBRE EL USO / ALVORENSTE GEBRUIKEN / OBSERVERA ANGÅENDE ANVÄNDNINGEN

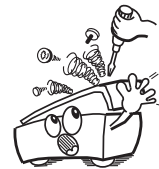
 <ul style="list-style-type: none"> • Avoid high temperatures. Allow for sufficient heat dispersion when installed in a rack. • Vermeiden Sie hohe Temperaturen. Beachten Sie, dass eine ausreichende Belüftung gewährleistet wird, wenn das Gerät auf ein Regal gestellt wird. • Eviter des températures élevées. Tenir compte d'une dispersion de chaleur suffisante lors de l'installation sur une étagère. • Evitate di esporre l'unità a temperature elevate. Assicuratevi che vi sia un'adeguata dispersione del calore quando installate l'unità in un mobile per componenti audio. • Evite altas temperaturas. Permite la suficiente dispersión del calor cuando está instalado en la consola. • Vermijd hoge temperaturen. Zorg er bij installatie in een audiorack voor, dat de door het toestel geproduceerde warmte goed kan worden afgevoerd. • Undvik höga temperaturer. Se till att det finns möjlighet till god värmeavledning vid monteringen i ett rack. 	 <ul style="list-style-type: none"> • Keep the unit free from moisture, water, and dust. • Halten Sie das Gerät von Feuchtigkeit, Wasser und Staub fern. • Protéger l'appareil contre l'humidité, l'eau et la poussière. • Tenete l'unità lontana dall'umidità, dall'acqua e dalla polvere. • Mantenga el equipo libre de humedad, agua y polvo. • Laat geen vochtigheid, water of stof in het apparaat binnendringen. • Utsätt inte apparaten för fukt, vatten och damm. 	 <ul style="list-style-type: none"> • Do not let foreign objects into the unit. • Lassen Sie keine fremden Gegenstände in das Gerät kommen. • Ne pas laisser des objets étrangers dans l'appareil. • Non inserite corpi estranei all'interno dell'unità. • No deje objetos extraños dentro del equipo. • Laat geen vreemde voorwerpen in dit apparaat vallen. • Se till att främmande föremål inte tränger in i apparaten. 	<p>CAUTION:</p> <ul style="list-style-type: none"> • The ventilation should not be impeded by covering the ventilation openings with items, such as newspapers, tablecloths, curtains, etc. • No naked flame sources, such as lighted candles, should be placed on the unit. • Observe and follow local regulations regarding battery disposal. • Do not expose the unit to dripping or splashing fluids. • Do not place objects filled with liquids, such as vases, on the unit. <p>ACHTUNG:</p> <ul style="list-style-type: none"> • Die Belüftung sollte auf keinen Fall durch das Abdecken der Belüftungsöffnungen durch Gegenstände wie beispielsweise Zeitungen, Tischtücher, Vorhänge o. Ä. behindert werden. • Auf dem Gerät sollten keinerlei direkte Feuerquellen wie beispielsweise angezündete Kerzen aufgestellt werden. • Bitte beachten Sie bei der Entsorgung der Batterien die örtlich geltenden Umweltbestimmungen. • Das Gerät sollte keiner tropfenden oder spritzenden Flüssigkeit ausgesetzt werden. • Auf dem Gerät sollten keine mit Flüssigkeit gefüllten Behälter wie beispielsweise Vasen aufgestellt werden.
 <ul style="list-style-type: none"> • Handle the power cord carefully. Hold the plug when unplugging the cord. • Gehen Sie vorsichtig mit dem Netzkabel um. Halten Sie das Kabel am Stecker, wenn Sie den Stecker herausziehen. • Manipuler le cordon d'alimentation avec précaution. Tenir la prise lors du débranchement du cordon. • Maneggiare il cavo di alimentazione con attenzione. Tenete ferma la spina quando scollegate il cavo dalla presa. • Maneje el cordón de energía con cuidado. Sostenga el enchufe cuando desconecte el cordón de energía. • Hanteer het netsnoer voorzichtig. Houd het snoer bij de stekker vast wanneer deze moet worden aan- of losgekoppeld. • Hantera nätkablen varsamt. Håll i kablarna när den kopplas från el-uttaget. 	 <ul style="list-style-type: none"> • Unplug the power cord when not using the unit for long periods of time. • Wenn das Gerät längere Zeit nicht verwendet werden soll, trennen Sie das Netzkabel vom Netzstecker. • Débrancher le cordon d'alimentation lorsque l'appareil n'est pas utilisé pendant de longues périodes. • Scollegate il cavo di alimentazione quando prevedete di non utilizzare l'unità per un lungo periodo di tempo. • Desconecte el cordón de energía cuando no utilice el equipo por mucho tiempo. • Neem altijd het netsnoer uit het stopcontact wanneer het apparaat gedurende een lange periode niet wordt gebruikt. • Koppla loss nätkablen om apparaten inte kommer att användas i lång tid. 	 <ul style="list-style-type: none"> • Do not let insecticides, benzene, and thinner come in contact with the unit. • Lassen Sie das Gerät nicht mit Insektiziden, Benzin oder Verdünnungsmitteln in Berührung kommen. • Ne pas mettre en contact des insecticides, du benzène et un diluant avec l'appareil. • Assicuratevi che l'unità non entri in contatto con insetticidi, benzolo o solventi. • No permita el contacto de insecticidas, gasolina y diluyentes con el equipo. • Voorkom dat insecticiden, benzeen of verfverdunder met dit toestel in contact komen. • Se till att inte insektsmedel på spraybruk, bensen och thinner kommer i kontakt med apparatens hölje. 	<p>ATTENTION:</p> <ul style="list-style-type: none"> • La ventilation ne doit pas être gênée en recouvrant les ouvertures de la ventilation avec des objets tels que journaux, rideaux, tissus, etc. • Aucune flamme nue, par exemple une bougie, ne doit être placée sur l'appareil. • Veillez à respecter les lois en vigueur lorsque vous jetez les piles usagées. • L'appareil ne doit pas être exposé à l'eau ou à l'humidité. • Ne pas poser d'objet contenant du liquide, par exemple un vase, sur l'appareil. <p>ATTENZIONE:</p> <ul style="list-style-type: none"> • Le aperture di ventilazione non devono essere ostruite coprendole con oggetti, quali giornali, tovaglie, tende e così via. • Non posizionate sull'unità fiamme libere, come ad esempio candele accese. • Prestate attenzione agli aspetti legati alla tutela dell'ambiente nello smaltimento delle batterie. • L'apparecchiatura non deve essere esposta a gocciolii o spruzzi. • Non posizionate sull'unità alcun oggetto contenente liquidi, come ad esempio i vasi. <p>PRECAUCIÓN:</p> <ul style="list-style-type: none"> • La ventilación no debe quedar obstruida por haberse cubierto las aperturas con objetos como periódicos, manteles, cortinas, etc. • No debe colocarse sobre el aparato ninguna fuente inflamable sin protección, como velas encendidas. • A la hora de deshacerse de las pilas, respete la normativa para el cuidado del medio ambiente. • No exponer el aparato al goteo o salpicaduras cuando se utilice. • No colocar sobre el aparato objetos llenos de líquido, como jarras.
	 <p>* (For apparatuses with ventilation holes)</p> <ul style="list-style-type: none"> • Do not obstruct the ventilation holes. • Decken Sie den Lüftungsbereich nicht ab. • Ne pas obstruer les trous d'aération. • Non coprite i fori di ventilazione. • No obstruya los orificios de ventilación. • De ventilatieopeningen mogen niet worden geblokkeerd. • Täpp inte till ventilationsöppningarna. 	 <ul style="list-style-type: none"> • Never disassemble or modify the unit in any way. • Versuchen Sie niemals das Gerät auseinander zu nehmen oder zu verändern. • Ne jamais démonter ou modifier l'appareil d'une manière ou d'une autre. • Non smontate né modificate l'unità in alcun modo. • Nunca desarme o modifique el equipo de ninguna manera. • Dit toestel mag niet gedemonteerd of aangepast worden. • Ta inte isär apparaten och försök inte bygga om den. 	<p>WAARSCHUWING:</p> <ul style="list-style-type: none"> • De ventilatie mag niet worden belemmerd door de ventilatieopeningen af te dekken met bijvoorbeeld kranten, een tafelkleed, gordijnen, enz. • Plaats geen open vlammen, bijvoorbeeld een brandende kaars, op het apparaat. • Houd u steeds aan de milieuvorschriften wanneer u gebruikte batterijen wegdoet. • Stel het apparaat niet bloot aan druppels of spatten. • Plaats geen voorwerpen gevuld met water, bijvoorbeeld een vaas, op het apparaat. <p>OBSERVERA:</p> <ul style="list-style-type: none"> • Ventilationen bör inte förhindras genom att täcka för ventilationsöppningarna med föremål såsom tidningar, bordsdukar, gardiner osv. • Inga blottade brandkällor, såsom tända ljus, får placeras på apparaten. • Tänk på miljöaspekterna när du bortskaffar batterier. • Apparaten får inte utsättas för vätska. • Placera inte föremål fyllda med vätska, t.ex. vaser, på apparaten.

A NOTE ABOUT RECYCLING:

This product's packaging materials are recyclable and can be reused. Please dispose of any materials in accordance with the local recycling regulations.

When discarding the unit, comply with local rules or regulations.

Batteries should never be thrown away or incinerated but disposed of in accordance with the local regulations concerning battery disposal.

This product and the supplied accessories, excluding the batteries, constitute the applicable product according to the WEEE directive.



HINWEIS ZUM RECYCLING:

Das Verpackungsmaterial dieses Produktes ist zum Recyceln geeignet und kann wieder verwendet werden. Bitte entsorgen Sie alle Materialien entsprechend der örtlichen Recycling-Vorschriften.

Beachten Sie bei der Entsorgung des Gerätes die örtlichen Vorschriften und Bestimmungen.

Die Batterien dürfen nicht in den Hausmüll geworfen oder verbrannt werden; bitte entsorgen Sie die Batterien gemäß der örtlichen Vorschriften.

Dieses Produkt und das im Lieferumfang enthaltene Zubehör (mit Ausnahme der Batterien!) entsprechen der WEEE-Direktive.

UNE REMARQUE CONCERNANT LE RECYCLAGE:

Les matériaux d'emballage de ce produit sont recyclables et peuvent être réutilisés. Veuillez disposer des matériaux conformément aux lois sur le recyclage en vigueur.

Lorsque vous mettez cet appareil au rebut, respectez les lois ou réglementations en vigueur.

Les piles ne doivent jamais être jetées ou incinérées, mais mises au rebut conformément aux lois en vigueur sur la mise au rebut des piles.

Ce produit et les accessoires inclus, à l'exception des piles, sont des produits conformes à la directive DEEE.

NOTA RELATIVA AL RICICLAGGIO:

I materiali di imballaggio di questo prodotto sono riutilizzabili e riciclabili. Smaltire i materiali conformemente alle normative locali sul riciclaggio.

Per lo smaltimento dell'unità, osservare le normative o le leggi locali in vigore.

Non gettare le batterie, né incenerirle, ma smaltirle conformemente alla normativa locale sui rifiuti chimici.

Questo prodotto e gli accessori inclusi nell'imballaggio sono applicabili alla direttiva RAEE, ad eccezione delle batterie.

ACERCA DEL RECICLAJE:

Los materiales de embalaje de este producto son reciclables y se pueden volver a utilizar. Disponga de estos materiales siguiendo los reglamentos de reciclaje de su localidad.

Cuando se deshaga de la unidad, cumpla con las reglas o reglamentos locales.

Las pilas nunca deberán tirarse ni incinerarse. Deberá disponer de ellas siguiendo los reglamentos de su localidad relacionados con los desperdicios químicos.

Este producto junto con los accesorios empaquetados es el producto aplicable a la directiva RAEE excepto pilas.

EEN AANTEKENING MET BETREKKING TOT DE RECYCLING:

Het inpakmateriaal van dit product is recycleerbaar en kan opnieuw gebruikt worden. Er wordt verzocht om zich van elk afvalmateriaal te ontdoen volgens de plaatselijke voorschriften.

Volg voor het wegdoen van de speler de voorschriften voor de verwijdering van wit- en bruingoed op.

Batterijen mogen nooit worden weggegooid of verbrand, maar moeten volgens de plaatselijke voorschriften betreffende chemisch afval worden verwijderd.

Op dit product en de meegeleverde accessoires, m.u.v. de batterijen is de richtlijn voor afgedankte elektrische en elektronische apparaten (WEEE) van toepassing.

OBSERVERA ANGÅENDE ÅTERVINNING:

Produktens emballage är återvinningsbart och kan återanvändas. Kassera det enligt lokala återvinningsbestämmelser.

När du kasserar enheten ska du göra det i överensstämmelse med lokala regler och bestämmelser.

Batterier får absolut inte kastas i soporna eller brännas. Kassera dem enligt lokala bestämmelser för kemiskt avfall.

Denna apparat och de tillbehör som levereras med den uppfyller gällande WEEE-direktiv, med undantag av batterierna.

1. IMPORTANT NOTICE: DO NOT MODIFY THIS PRODUCT

This product, when installed as indicated in the instructions contained in this manual, meets R&TTE directive requirements. Modification of the product could result in hazardous Radio and EMC radiation.

2. CAUTION

- Separation distance of at least 20 cm must be maintained between the antenna of this product and all persons.
- This product and its antenna must not be co-located or operating in conjunction with any other antenna or transmitter.

1. WICHTIGER HINWEIS: NEHMEN SIE KEINE VERÄNDERUNGEN AN DIESEM PRODUKT VOR

Wenn dieses Produkt entsprechend dieser Bedienungsanleitung aufgebaut wird, entspricht es den Anforderungen der R&TTE-Richtlinie. Veränderungen am Produkt können zu gefährlicher Funk- und EMV-Strahlung führen.

2. VORSICHT

- Zwischen der Antenne dieses Produkts und Personen muss ein Schutzabstand von 20 cm eingehalten werden.
- Dieses Produkt und seine Antenne dürfen nicht neben anderen Antennen oder Sendern aufgestellt oder zusammen mit ihnen verwendet werden.

1. MISE EN GARDE IMPORTANTE : NE JAMAIS MODIFIER CE PRODUIT

Si toutes les consignes indiquées dans ce mode ont été respectées pendant son installation, ce produit est conforme aux directives R&TTE. Toute modification du produit risquerait alors de générer des radiations radio et EMC dangereuses.

2. ATTENTION

- L'antenne de l'appareil devra être située à une distance de 20 cm au moins des personnes.
- Ce produit ainsi que son antenne ne devront en aucun cas être utilisés à proximité d'une autre antenne ou transmetteur.

1. AVVERTENZA IMPORTANTE: NON MODIFICARE QUESTO PRODOTTO

Se installato come indicato nelle istruzioni del presente manuale, questo prodotto soddisfa i requisiti della direttiva R&TTE. Eventuali modifiche apportate al prodotto potrebbero causare pericolose radiazioni radio ed EMC.

2. ATTENZIONE

- È necessario mantenere una distanza minima di 20 cm tra l'antenna di questo prodotto e le persone.
- Questo prodotto e la relativa antenna non devono essere posizionati in prossimità di altre antenne o trasmettitori e non devono essere utilizzati congiuntamente a questi ultimi.

1. NOTA IMPORTANTE: NO MODIFIQUE ESTE PRODUCTO

Este producto, si es instalado de acuerdo con las instrucciones contenidas en este manual, cumple los requisitos de la directiva R&TTE. La modificación del producto puede producir radiación de Radio y EMC peligrosa.

2. PRECAUCIÓN

- Se debe mantener una separación de al menos 20 cm entre la antena del producto y las personas.
- Este producto y su antena no debe instalarse ni utilizarse conjuntamente con otra antena o transmisor.

1. BELANGRIJKE MEDEDELING: BRENG AAN DIT PRODUCT GEEN AANPASSINGEN AAN

Dit product, indien geïnstalleerd volgens de aanwijzingen in deze gebruiksaanwijzing, voldoet aan de vereisten van de R&TTE-richtlijn. Aanpassing van dit product kan gevaarlijke radio- en EMC-straling tot gevolg hebben.

2. LET OP

- Houd tussen antenne en personen altijd een afstand van tenminste 20 cm aan.
- Dit product en zijn antenne mogen niet in de buurt van een andere antenne of zender worden geplaatst of in combinatie daarmee worden gebruikt.

1. VIKTIGT: APPARATEN FÅR INTE MODIFIERAS

Under förutsättning att apparaten installeras enligt anvisningarna i denna bruksanvisning, uppfyller denna kraven i R&TTE-direktivet. Ev. modifiering av apparaten kan resultera i farlig radio- och elektromagnetisk strålning.

2. FÖRSIKTIG

- Se till att det finns ett avstånd på minst 20 cm mellan apparatens antenn och personer i omgivningen.
- Apparaten och dess antenn får inte placeras eller användas i närheten av andra antenner eller sändare.

Contents

Getting Started	
Accessories	1
Cautions on Handling	2
Cautions on Installation	2
About the Remote Control Unit	2
Inserting the Batteries	2
Operating Range of the Remote Control Unit	2
Part Names and Functions	3
Top Panel	3
Front Panel	3
Rear Panel	4
Remote Control Unit	4
Connections	
Preparations	5
Cables Used for Connections	5
Connecting the Playback Components	5
iPod®	5
Connections to Other Devices	5
Antenna Terminals	5, 6
Connection to a Subwoofer	6
Network Audio	6, 7
Connecting the Power Cord	7
Menu Operations	
Operations	8
Menu Map	8
Setup	
SETUP	8
1 Clock	8
2 Network Setting	9 ~ 11
3 Firmware Update	11

Playback	
Preparations	12
Turning the Function ON and OFF	12
Input Source Switching	12
Adjusting the Master Volume	12
Switching the Display	13
Switching the Display's Brightness	13
Listening with Headphones	13
Playing Network Audio	13
Listening to Internet Radio	14
Tuning in Broadcast Stations	14
Listening to PC Music	15
Playing Files Stored on a Computer	15
Listening to iPod	16
iPod® Playback	16
Listening to Music	16
Listening to FM/AM	17
Tuning in Broadcast Stations	17
Presetting Radio Stations (Preset Memory)	17
Naming Preset Broadcast Stations	17
Listening to Preset Stations	17
RDS (Radio Data System)	18
RDS Search	18
PTY Search	19
TP Search	19
Listening to AUX	19
Playing a Portable Audio	19
Favorite	19
Advanced Operation	
Alarm Setting	20
Setting the Sleep Timer	21
Convenient Functions	21
Personal Memory Plus Function	21
Last Function Memory	21
Backup Memory	21
Auto Power On	21
Resetting the Microprocessor	21
Other Information	22, 23
Troubleshooting	24, 25
Specifications	26

Getting Started

Thank you for purchasing this DENON product. To ensure proper operation, please read this owner's manual carefully before using the product. After reading them, be sure to keep them for future reference.

Accessories

Check that the following parts are supplied with the product.

- ① Remote control (RC-1089) 1
- ② R03/AAA batteries 2
- ③ AM loop antenna 1
- ④ FM indoor antenna 1
- ⑤ Rod antenna for wireless LAN 1
- ⑥ Power cord (Cord length: Approx. 2 m) 1
- ⑦ Universal Adapter (3 types) 1 each
- ⑧ Owner's manual 1
- ⑨ Service station list 1

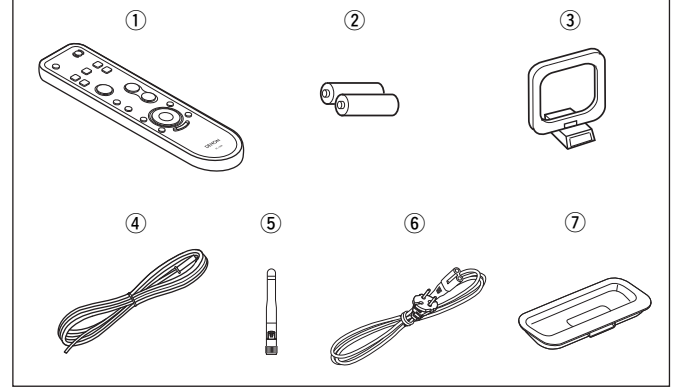

Cautions on Handling

- Before turning the power switch on**
 Check once again that all connections are correct and that there are no problems with the connection cables.
- Power is supplied to some of the circuitry even when the unit is set to the standby mode. When traveling or leaving home for long periods of time, be sure to unplug the power cord from the power outlet.
- About condensation**
 If there is a major difference in temperature between the inside of the unit and the surroundings, condensation (dew) may form on the operating parts inside the unit, causing the unit not to operate properly.
 If this happens, let the unit sit for an hour or two with the power turned off and wait until there is little difference in temperature before using the unit.
- Cautions on using mobile phones**
 Using a mobile phone near this unit may result in noise. If so, move the mobile phone away from this unit when it is in use.
- Moving the unit**
 Turn off the power and unplug the power cord from the power outlet.
 Next, disconnect the connection cables to other system units before moving the unit.
- Note that the illustrations in these instructions may differ from the actual unit for explanation purposes.

Cautions on Installation

Note:
For proper heat dispersal, do not install this unit in a confined space, such as a bookcase or similar enclosure.

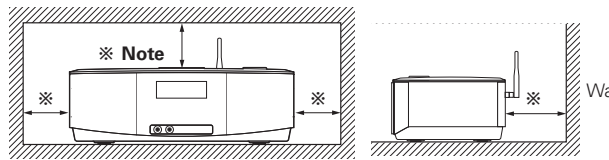

About the Remote Control Unit

Inserting the Batteries

- Slide the rear lid in the direction of the arrow and remove it.
- Load the two batteries properly as indicated by the marks in the battery compartment.

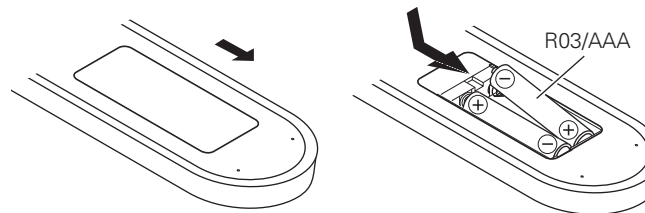

- Put the rear cover back on.

NOTE

- Replace the batteries with new ones if the set does not operate even when the remote control unit is operated close to the unit.
- The supplied batteries are only for verifying operation.
- When inserting the batteries, be sure to do so in the proper direction, following the "⊕" and "⊖" marks in the battery compartment.
- To prevent damage or leakage of battery fluid:
 - Do not use a new battery together with an old one.
 - Do not use two different types of batteries.
 - Do not attempt to charge dry batteries.
 - Do not short-circuit, disassemble, heat or dispose of batteries in flames.
- If the battery fluid should leak, carefully wipe the fluid off the inside of the battery compartment and insert new batteries.
- Remove the batteries from the remote control unit if it will not be in use for long periods.
- When replacing the batteries, have the new batteries ready and insert them as quickly as possible.

Operating Range of the Remote Control Unit

Point the remote control unit at the remote sensor when operating it.

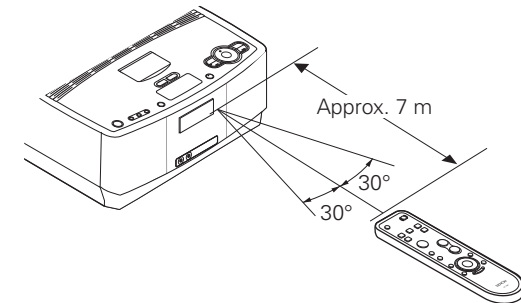

NOTE

The set may function improperly or the remote control unit may not operate if the remote control sensor is exposed to direct sunlight, strong artificial light from an inverter type fluorescent lamp or infrared light.

Part Names and Functions

For buttons not explained here, see the page indicated in parentheses ().

Top Panel

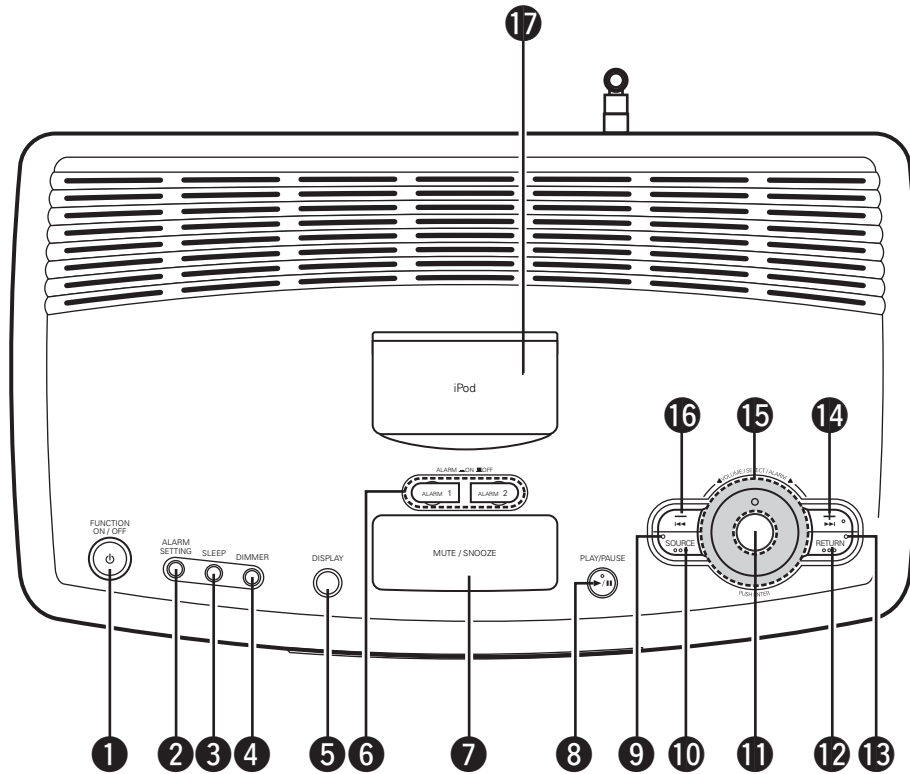

- 1 Power operation button (FUNCTION ON / OFF) (12)
- 2 ALARM SETTING button (20)
- 3 SLEEP button (21)
- 4 DIMMER button (13)
- 5 DISPLAY button (13)
- 6 ALARM1, 2 ON / OFF buttons (20)
- 7 MUTE / SNOOZE button (12, 20)
- 8 PLAY / PAUSE button (▶/||) (16)
- 9 SOURCE indicator (12)
- 10 SOURCE button (8)
- 11 ENTER button (8)
- 12 RETURN button (8)
- 13 RETURN indicator (12)
- 14 Forward-skip / Fast-forwarding button (▶▶|) (15)
- 15 Multi jog dial / Master volume control (8, 12)
- 16 Reverse-skip / Fast-reversing button (|◀◀) (15)
- 17 Dock for iPod (5)

Front Panel

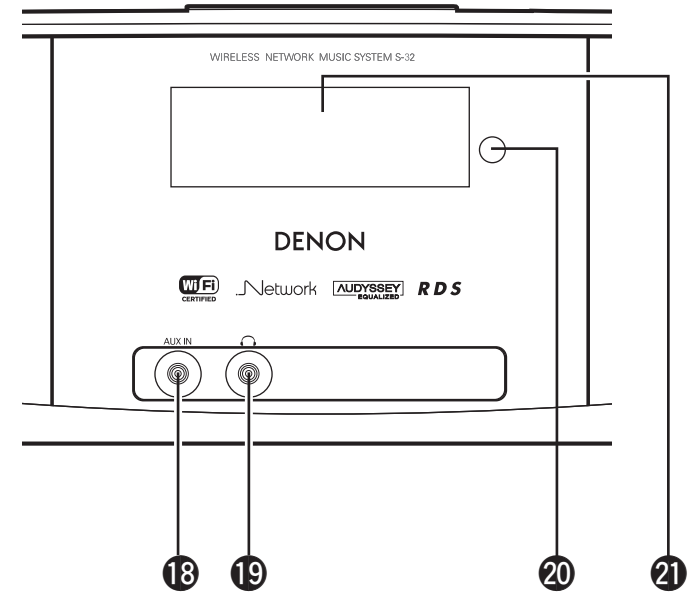

- 18 AUX IN jack (19)
- 19 Headphones jack (⌣) (13)
- 20 Remote control sensor (2)
- 21 Display

Rear Panel

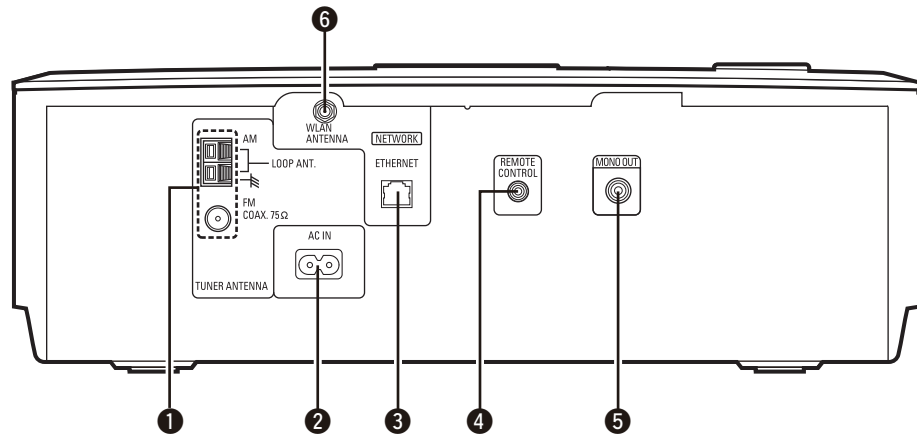

- ❶ FM/AM antenna terminals (TUNER ANTENNA) (5)
- ❷ AC inlet (AC IN) (7)
- ❸ ETHERNET connector (6)
- ❹ REMOTE CONTROL jack
This jack will be used in the future for additional functions.
- ❺ Monaural audio connector (MONO OUT) (6)
- ❻ WLAN ANTENNA terminal (6)

Remote Control Unit

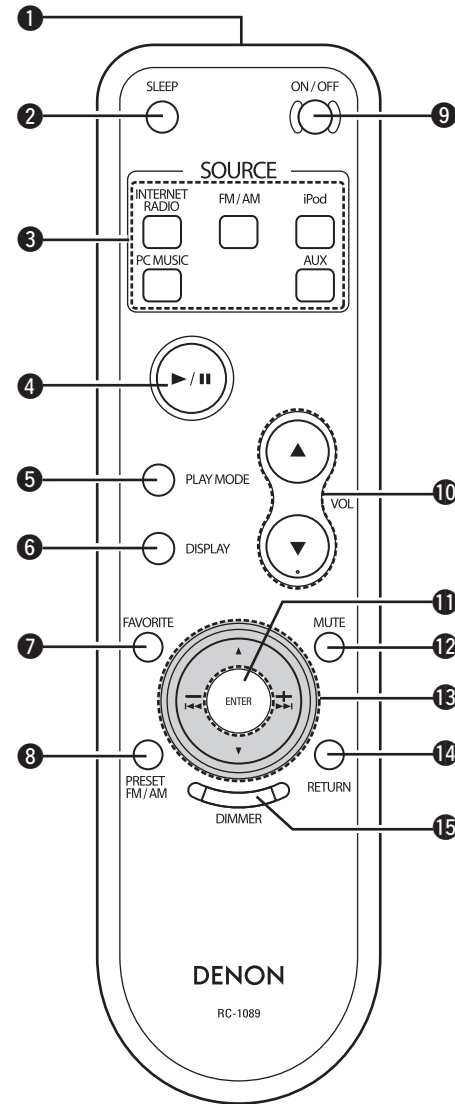

- ❶ Remote control signal transmitter (2)
- ❷ SLEEP button (21)
- ❸ SOURCE select buttons (12)
- ❹ Play / Pause button (▶/⏸) (16)
- ❺ PLAY MODE button (16)
- ❻ DISPLAY button (13)
- ❼ FAVORITE button (19)
- ❽ PRESET FM/AM button (17)
- ❾ Function ON / OFF button (12)
- ❿ Master volume control buttons (VOL) (12)
- ⓫ ENTER button (8)
- ⓬ Muting button (MUTE) (12)
- ⓭ Cursor (△▽) / Skip (◀◀▶▶) / TUNING + - buttons (8, 15, 17)
- ⓮ RETURN button (8)
- ⓯ DIMMER button (13)

Connections

Connections for all compatible audio signal formats are described in these operating instructions. Please select the types of connections suited for the equipment you are connecting. With some types of connections, certain settings must be made on the S-32. For details, refer to the instructions for the respective connection items below.

- NOTE**
- Do not plug in the power cord until all connections have been completed.
 - When making connections, also refer to the owner's manual of the other components.

Preparations

Cables Used for Connections

Select the cables according to the equipment being connected.

Audio cables

Analog connections (Subwoofer)



(Black) Pin - plug cable

Network connections (Wired LAN)



LAN cable

Signal direction

Audio signal:

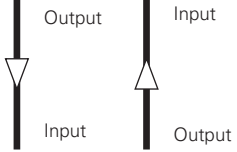

Connecting the Playback Components

iPod®

Open the lid and mount the adapter suited for your iPod onto the S-32's adapter insertion slot.

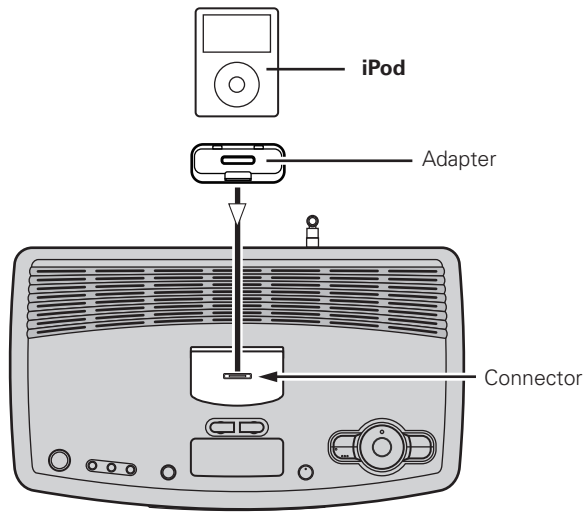

NOTE

Note that leaning the iPod forward or backward when connecting it to or disconnecting it from the dock for iPod may damage the connector.

 Keep the dock for iPod's lid closed when your iPod is not connected to prevent any foreign objects from getting inside.

Stamped indication	iPod connectable to the S-32
mini	iPod mini
Photo 20, 30GB	iPod Photo 30GB/iPod 20GB with color display
Photo 60GB	iPod Photo 60GB/iPod 40GB with color display

Connections to Other Devices

Antenna Terminals

An FM antenna cable plug can be connected directly.

AM/FM

Direction of broadcasting station

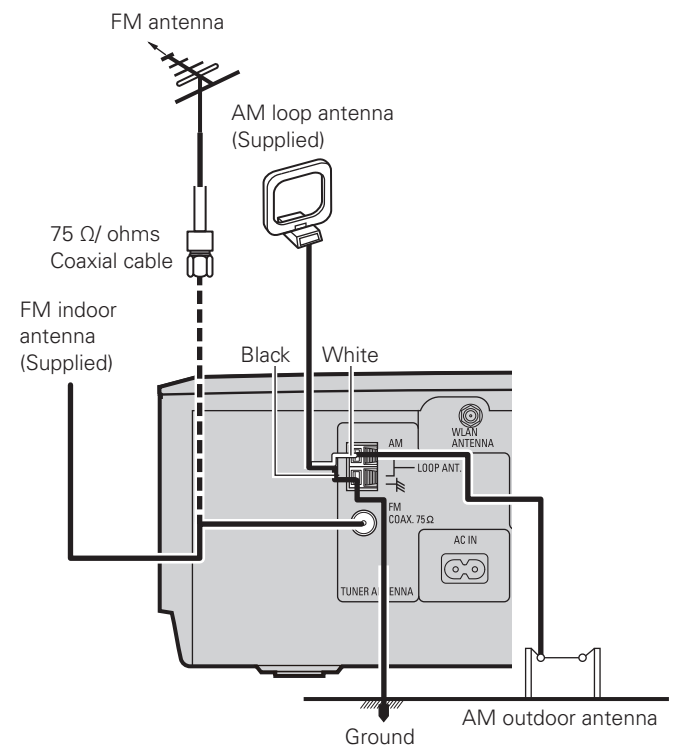

AM loop antenna assembly

- ① Remove the vinyl tie and take out the connection line.
 - ② Connect to the AM antenna terminals.
 - ③ Bend in the reverse direction.
 - ④ Mount
 - a. With the antenna on top any stable surface.
 - b. With the antenna attached to a wall.
- Installation hole Mount on wall, etc.

Connection of AM antennas

1. Push the lever.
2. Insert the conductor.
3. Return the lever.

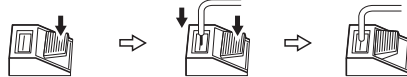

NOTE

- Do not connect two FM antennas simultaneously.
- Even if an external AM antenna is used, do not disconnect the AM loop antenna.
- Make sure the AM loop antenna lead terminals do not touch metal parts of the panel.

Connection to a Subwoofer

Use connected to a subwoofer.

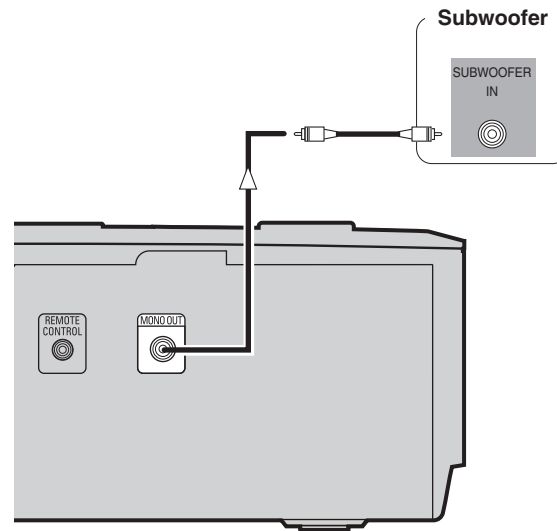

NOTE

When turning the power ON/OFF:
 ON: First turn on the power to the main unit, then turn on the power to the subwoofer.
 OFF: First turn off the power to the subwoofer, then turn off the power to the main unit.

Network Audio

[Wired LAN]

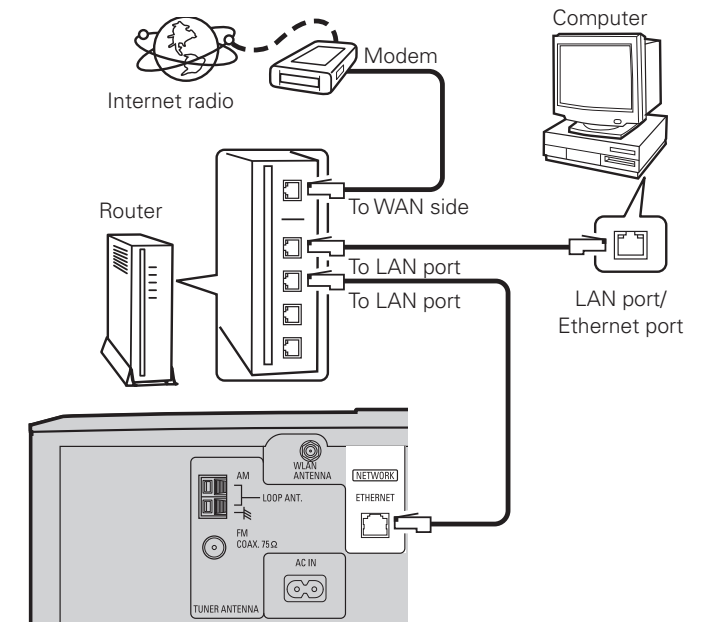

[Wireless LAN]

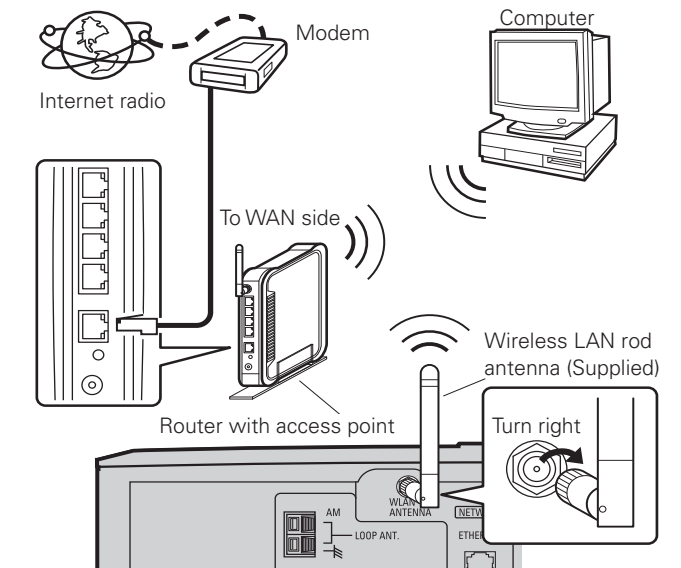

Required System

❑ Broadband Internet Connection

A broadband line connection to the Internet is required in order to use the S-32's Internet radio function.

❑ Modem

This is a device that is connected to the broadband line to communicate with the Internet.

❑ Router

When using the S-32, we recommend you to use a router equipped with the following functions:

- Built-in DHCP (Dynamic Host Configuration Protocol) server
This function automatically assigns IP addresses on the LAN.
- Built-in 100 BASE-TX switch

When connecting multiple devices, we recommend a switching hub with a speed of 100 Mbps or greater.

❑ Ethernet Cable (CAT-5 or greater recommended)

The S-32 does not come with an Ethernet cable. Purchase a cable of the required length.

❑ Computer

A computer with the following specifications is required to operate the music server:

- OS
Windows® XP Service Pack2, Windows Vista
- Software
.NET Framework 1.1, Windows Media Connect (Windows XP), Windows Media Player Ver.11
- Internet browser
Microsoft Internet Explorer 5.01 or later
- LAN port
- 300 MB or more free disk space

※Free space is required to save music files. The following sizes are approximate.

Format	Bit rate	Per minute	Per hour
MP3 / WMA	128 kbps	Approx. 1 MB	Approx. 60 MB
	192 kbps	Approx. 1.5 MB	Approx. 90 MB
MPEG-4 AAC	256 kbps	Approx. 2 MB	Approx. 120 MB
	392 kbps	Approx. 3 MB	Approx. 180 MB
WAV (LPCM)	1400 kbps	Approx. 10 MB	Approx. 600 MB
FLAC	1080 kbps	Approx. 7.7 MB	Approx. 464 MB

(1 MB = 10⁶ bytes)



- Depending on the server, video files may be displayed, but they cannot be played on the S-32.
- For connections to the Internet, contact an ISP (Internet Service Provider) or a computer shop.
- The types of routers that can be used depend on the ISP. Contact an ISP (Internet Service Provider) or a computer shop for details.

NOTE

A contract with an ISP is required to connect to the Internet. No additional contract is needed if you already have a broadband connection to the Internet.

❑ Others

- If you have an ISP contract for a line on which network settings are made manually, make the settings at "Network Setting" (page 9, 10).
- When using a broadband router (DHCP function), the S-32 makes the network settings automatically, so there is no need to make them yourself.
- If connecting the S-32 to a network with no DHCP function, make the settings at "Network Setting" (page 9, 10).
- The S-32 is not compatible with PPPoE. A PPPoE-compatible router is required if you have a contract for a line of the type with which the PPPoE is set.
- Depending on the ISP with which you have your contract, it may be necessary to make proxy server settings to use the Internet radio function. If you made proxy server settings on the computer to connect to the Internet, make the same proxy server settings on the S-32.
- The S-32 uses the DHCP and Auto IP functions to make the network settings automatically.

❑ Ethernet Cable (CAT-5 or greater recommended)

No Ethernet cable is included with the S-32. Procure a cable with the necessary length.

NOTE

Be sure to use a shielded type cable for Ethernet connections. Depending on the connected computer/router, there may be much noise generated from the cable.

Connecting the Power Cord

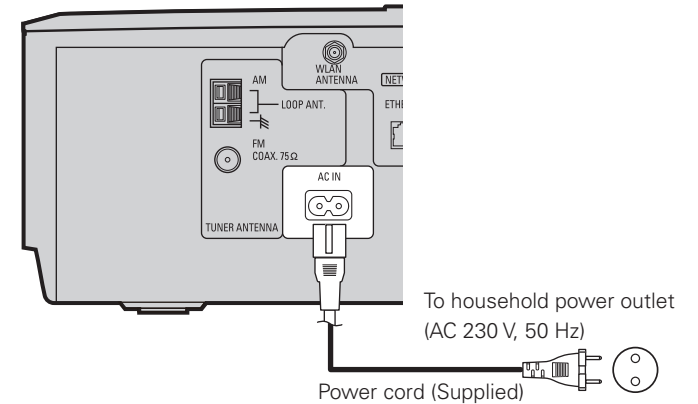

NOTE

- Only use the supplied power cord.
- Be sure the power cord is unplugged from the power outlet before connecting or disconnecting it to the AC inlet.

Protector circuit

The protection circuit will be activated in the following cases:

- When the temperature around the set is extremely high
- When the set is used for long periods of time with a high output and the internal temperature rises

Speaker output is suspended when the protector circuit operates. In this case, remove the power cord, make sure there is adequate ventilation and wait for the main unit to cool down. Afterwards, re-insert the power cord.

If the protection circuit is activated again even though there are no problems with the wiring or the ventilation around the unit, switch off the power and contact a DENON service center.

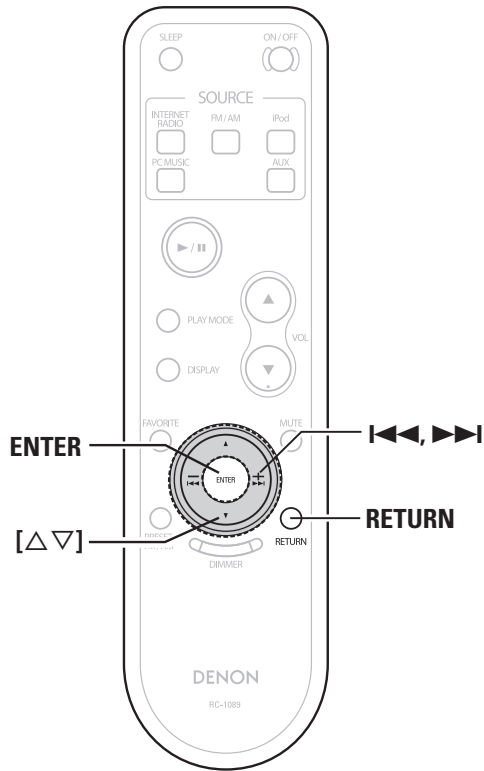
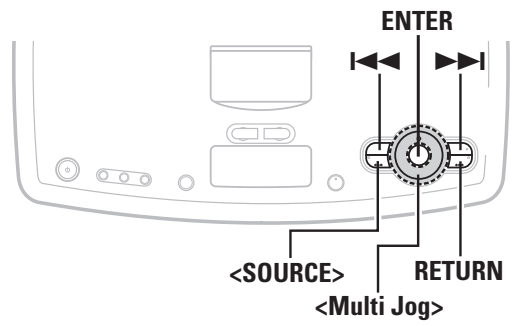

About the button names in these explanations
 < > : Buttons on the main unit
 [] : Buttons on the remote control unit
Button name only:
 Buttons on the main unit and remote control unit

Menu Operations

With the S-32, settings and operations for most functions can be performed by operating while looking at the menu displayed on the display.

Operations

- 1** Press **<SOURCE>**.
The menu is displayed.
- 2** Turn **<Multi Jog>** or press **|<<>>>|** to select "SETUP", then press **ENTER**.
- 3** Turn **<Multi Jog>** or press **[Δ∇]** to select the menu to be set or operated.
※ To return to the previous item, press **RETURN**.
- 4** Press **ENTER** to enter the setting.

Menu Map

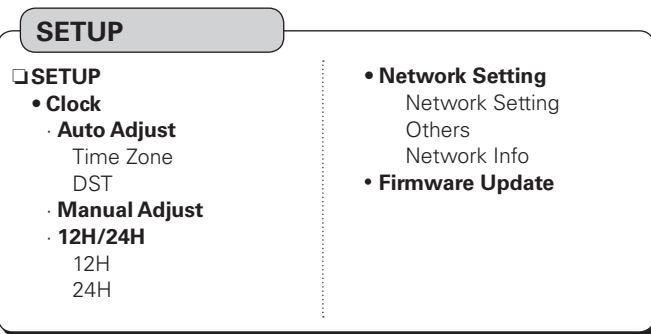

Setup

SETUP

Use the procedures described below to make various settings.

- Menu tree ●

1 Clock

Use this procedure to set the time.

Auto Adjust

Connect to the network to set the current time automatically.

[Selectable items]

Time Zone : Choose the region in which the set is installed in order to correct for the time difference.

DST : Make the daylight saving time setting.

NOTE
 Network connections are required.

Manual Adjust

Set the current time manually.

When setting the time, turn **<Multi Jog>** on the main unit clockwise to move the time forward, counterclockwise to move the time backward.

12H/24H

Choose whether to display the time in the 12-hour or 24-hour mode.

2 Network Setting

Make settings for wired or wireless LAN.

Wired LAN

Make settings for wired LAN.

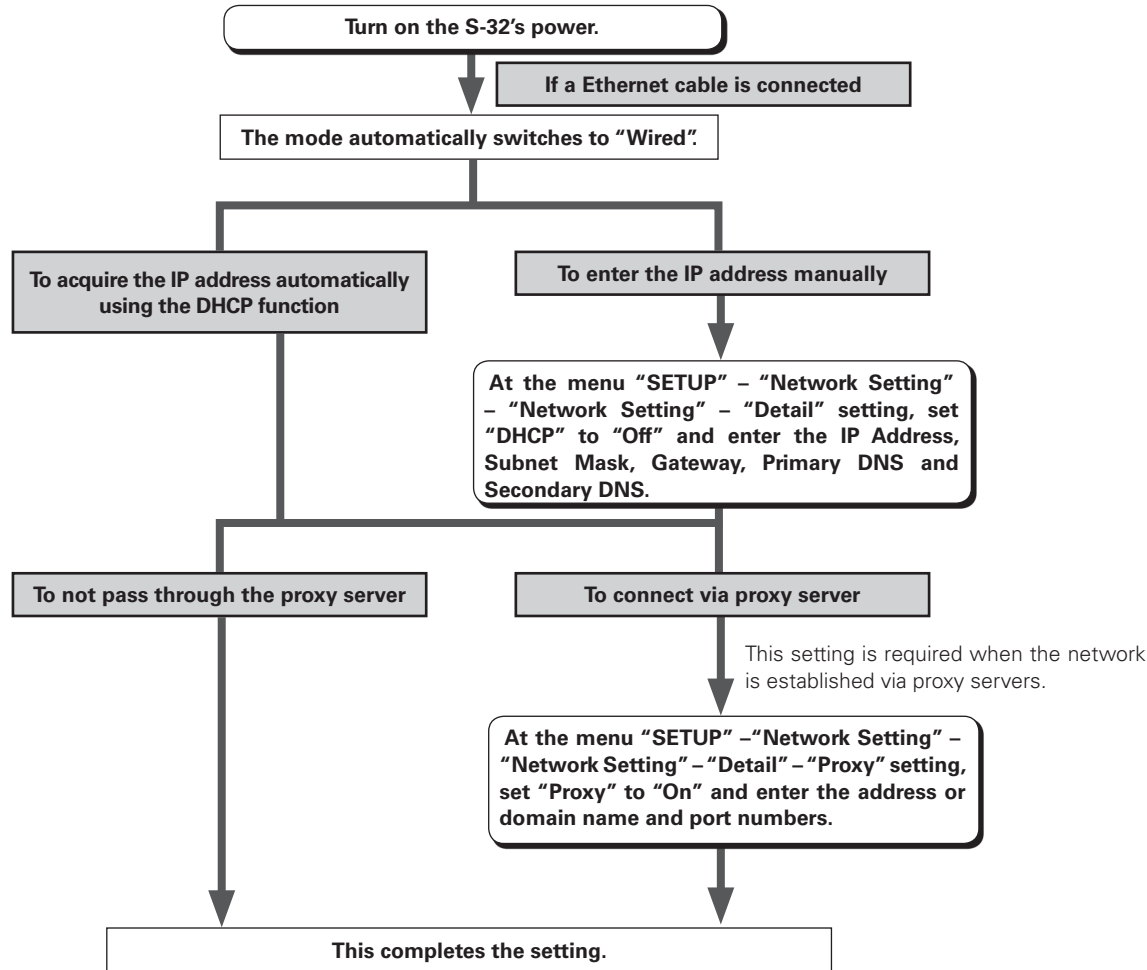

Recheck the connections and settings if you cannot connect to the Internet (☞ page 6).

NOTE Knowledge about networks is required to make the IP Address and Proxy settings. For details, consult a network administrator.

Wireless LAN Settings

Make settings for wireless LAN.

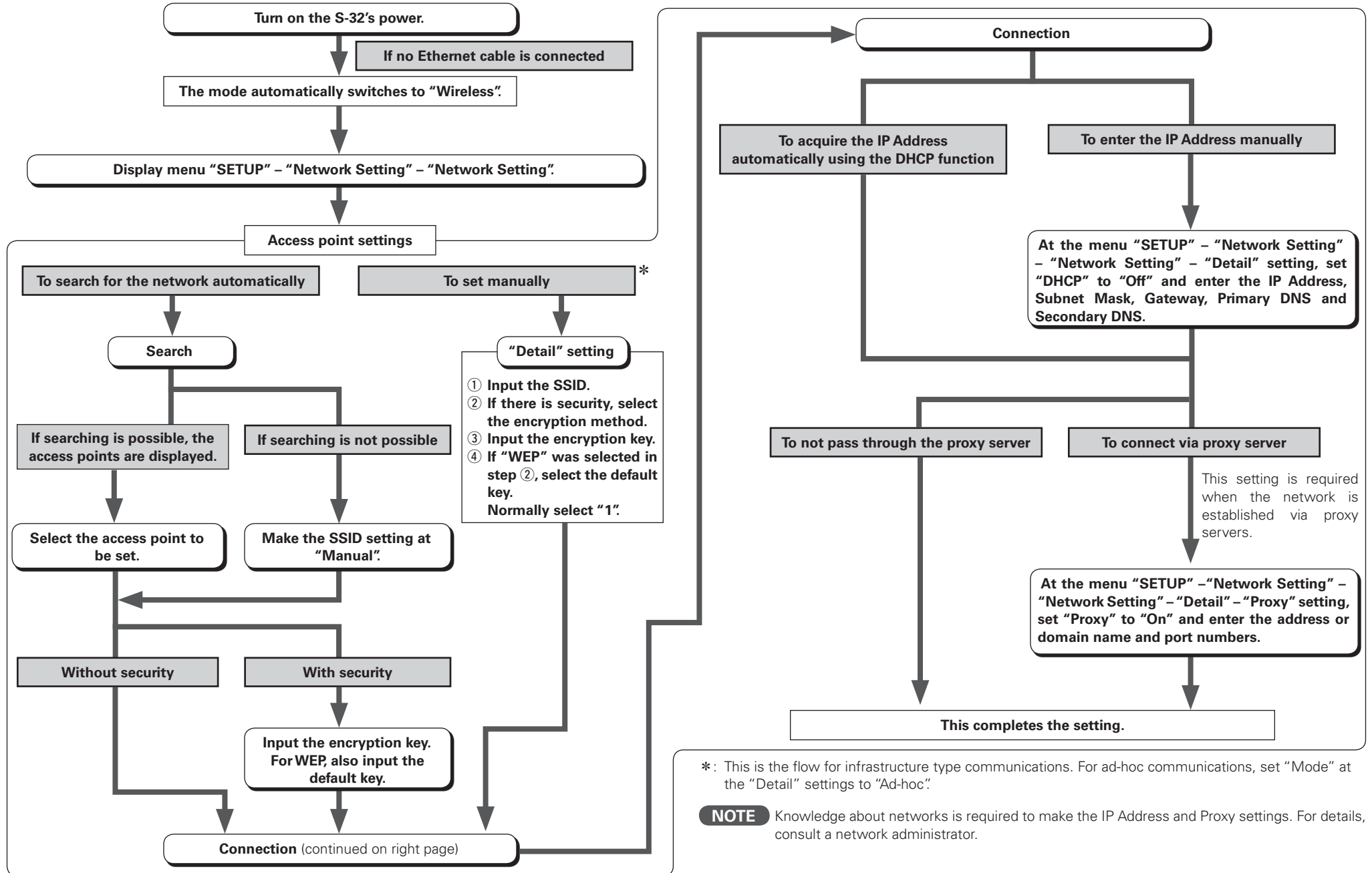

Other

Make setting for computer language environment.

PC Language

Select computer environment language.

[Selectable items]	ara	chi (smp)	chi (trad)	cze	dan		
	dut	eng	fin	fre	ger	gre	heb
	hun	ita	jpn	kor	nor	pol	por
	por (BR)	rus	spa	swe	tur		

Default Language

Select the language you want to display Internet Radio information.

[Selectable items]

English	German	French	Italian
Spanish	Nederlandish	Swedish	

Network Information

Display network information.

[Items to be checked]	Wired or Wireless	SSID
	DHCP= On or Off	IP Address
	MAC Address	

3 Firmware Update

Update the firmware.

Normally there is no need to use this function, aside from the cases described below.

- The Firmware Update function is only used for updating the firmware via the Internet, for example for the purpose of adding functions to the S-32 in the future.
- Information regarding the Firmware Update function will be announced on the DENON web site each time related plans are defined.
- A broadband connection to the Internet is required to use this function (☞ page 9).
- Even with a broadband connection to the Internet, approximately 30 minutes is required for the updating procedure to be completed. Once updating starts, normal operations on the S-32 cannot be performed until updating is completed. Furthermore, updating the firmware may reset the backup data for the parameters, etc., set for the S-32.

NOTE

- Connection to the network and specific settings are required to update the firmware. For details, see page 6, 9.
- Do not turn off the power until updating is completed.

Switching the Display

Press DISPLAY.

During playback, the time is displayed. The time is also displayed when the power is turned on.

Switching the Display's Brightness

Press DIMMER.

The brightness switches each time this is pressed.

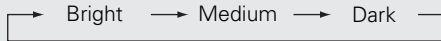

Listening with Headphones

Plug the headphones (sold separately) into .

※ The sound from the speakers is automatically cut off.

NOTE

Be careful not to set the volume too high when using headphones.

Playing Network Audio

This procedure can be used to play Internet radio stations or music stored on a computer.

□ About the Internet radio function

- Internet radio refers to radio broadcasts distributed over the Internet. Internet radio stations from around the world can be tuned in.
- The S-32 is equipped with the following Internet radio functions:
 - Stations can be selected by genre and region.
 - Internet radio stations can be preset.
 - Internet radio stations in MP3 and WMA (Windows Media Audio) format can be listened to.
 - Your favorite radio stations can be registered by accessing an exclusive DENON Internet radio URL from a Web browser on a computer.
 - ※ The function is managed for individual users, so you must provide your MAC or e-mail address.
 - Exclusive URL: <http://www.radiodenon.com>
 - ※ The radio station database service may be suspended without notice.
- The S-32's Internet radio station list is created using a radio station database service (vTuner). This database service provides a list edited and created for the S-32. vTuner services may be discontinued without notice.

□ Music server

- This function lets you play music files and playlists (m3u, wpl) stored on a computer (music server) connected to the S-32 via a network.
- With the S-32's network audio playback function, connection to the server is possible using one of the technologies below.
- Windows Media Player Network Sharing Service
 - Windows Media DRM10

Installing Windows Media Player ver. 11

- ① If Windows XP Service Pack 2 has not yet been installed, either download it free of charge from Microsoft or install it via a Windows update installer.
 - ② Download the latest version of Windows Media Player ver. 11, either directly from Microsoft or using a Windows update installer.
- ※ When using Windows Vista, there is no need to download a new version of Windows Media Player.

[Compatible formats]

	Internet radio	Music server [※]
WMA (Windows Media Audio)	○	○
MP3 (MPEG-1 Audio Layer-3)	○	○
WAV *	-	○
MPEG-4 AAC	-	○*
FLAC (Free Lossless Audio Codec)	-	○

*: Only files that are not protected by copyright can be played on the S-32.

※ Contents downloaded from pay sites on the Internet are copyright protected. Also, files encoded in WMA format when ripped from a CD, etc., on a computer may be copyright protected, depending on the computer's settings.

- The S-32 is compatible with MP3 ID3-Tag (Ver. 2) standards.
- The S-32 is compatible with WMA META tags.

[Playable formats]

	Sampling frequency	Bit rate	Extension
WMA (Windows Media Audio)	32/44.1/48 kHz	48~192 kbps	.wma
MP3 (MPEG-1 Audio Layer-3)	32/44.1/48 kHz	32~320 kbps	.mp3
WAV	32/44.1/48 kHz	-	.wav
MPEG-4 AAC	32/44.1/48 kHz	16~320 kbps	.aac/.m4a/.mp4
FLAC (Free Lossless Audio Codec)	32/44.1/48 kHz	-	.flac

WAV format Quantization bit rate: 16 bits.

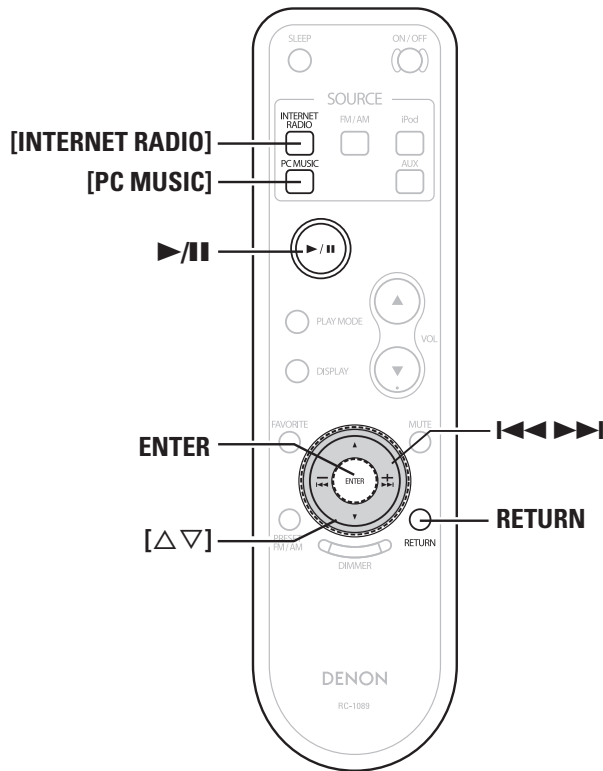
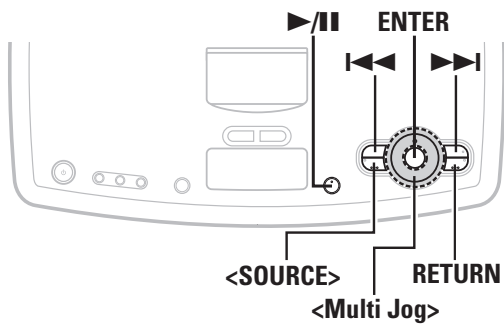

About the button names in these explanations

< > : Buttons on the main unit
 [] : Buttons on the remote control unit

Button name only:

Buttons on the main unit and remote control unit

Listening to Internet Radio



Tuning in Broadcast Stations

- 1** Either turn <Multi Jog> or press |◀◀ ▶▶| after pressing <SOURCE> to select “Internet Radio” then press the ENTER, or press [INTERNET RADIO].
- 2** Either turn <Multi Jog> or press [Δ ∇] to select the item you want to play, then press ENTER.
 The station list is displayed.
 A “♪” mark is indicated in front of stations that can be played.
- 3** Either turn <Multi Jog> or press [Δ ∇] to select the station, then press ENTER.
 Playback starts once buffering reaches “100%.”

To stop

During the play or pause mode, press and hold in ▶/|| for at least 2 seconds.



- Before listening to Internet radio
 - Check the network environment, then turn on the S-32’s power. (“Turning the Function ON and OFF” (page 12), “Network Audio” (page 6).)
 - If settings are required, make the network settings. (“Network Setting” (page 9, 10).)
- There are many Internet radio stations on the Internet, and the quality of the programs they broadcast as well as the bit rate of the tracks varies widely.
 Generally, the higher the bit rate, the higher the sound quality, but depending on the communication lines and server traffic, the music or audio signals being streamed may be interrupted.
 Inversely, lower bit rates mean a lower sound quality but less tendency for the sound to be interrupted.
- “Server Full” or “Connection Down” is displayed if the station is busy or not broadcasting.
- On the S-32, folder and file names can be displayed as titles. Any characters that cannot be displayed are replaced with “.” (period).”

Registering Internet Radio Stations as Your Favorites

Internet Radio stations can be stored in the favorites and played. “Favorite” (page 19)

Listening to PC Music



Playing Files Stored on a Computer

Use this procedure to play music files or playlists.

1 Either turn <Multi Jog> or press **◀◀ ▶▶** after pressing <SOURCE> to select “PC Music” then press **ENTER**, or press [PC MUSIC].

2 Either turn <Multi Jog> or press [**△ ▽**] to select the host name of the computer on which the music file you want to play is located, then press **ENTER**.

3 Either turn <Multi Jog> or press [**△ ▽**] to select the search item or folder, then press **ENTER**.

※ When a folder is selected and **▶||** is pressed, playback of the files in the folder begins.

4 Either turn <Multi Jog> or press [**△ ▽**] to select the file, then press **ENTER**.

※ During playback, press **▶||** to pause. Press **▶||** again to resume playback.

※ Press **RETURN** during playback to return to the previous menu screen.

※ Press **ENTER** during play to change to Artist display or Album display.

Selecting tracks

During playback, either press **◀◀** (reverse track) or **▶▶** (forward track).



- Connections to the required system and specific settings must be made in order to play music files (☞ page 7).
- Before starting, you must launch the computer’s server software and set the files as server contents. For details, see the operating instructions of your server software.

Registering PC Music as Your Favorites

Music files can be stored in the favorites and played. “Favorite” (☞ page 19)

NOTE

- Favorites are erased by overwriting them.
- When the operation described below is performed, the music server’s database is updated and it may no longer be possible to play or registering music files.
 - When you quit the music server and then restart it.
 - When music files are deleted or added on the music server.

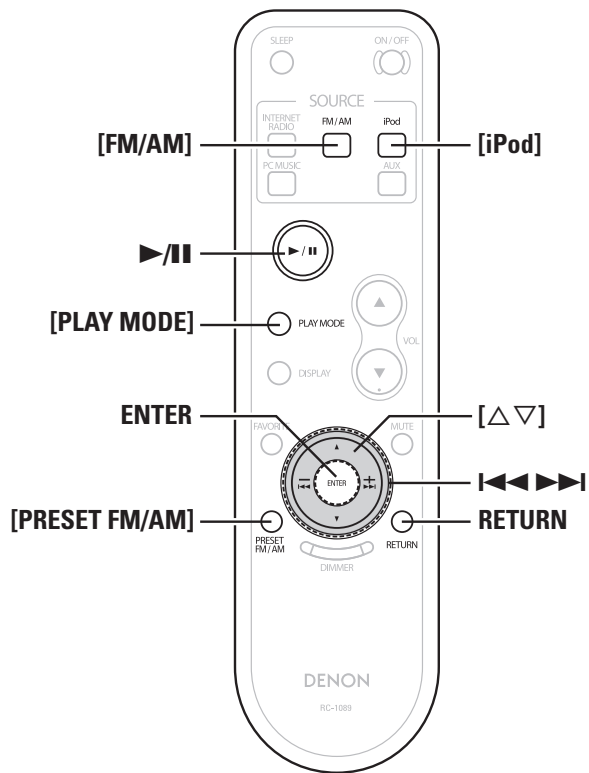
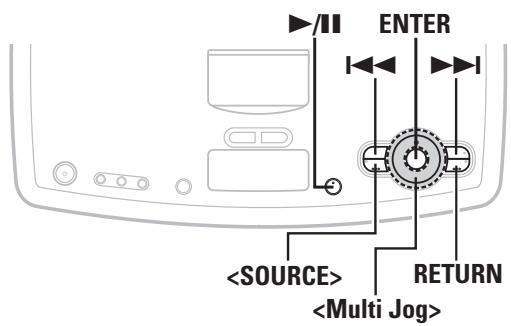

Listening to iPod



iPod® Playback

You can listen to music on an iPod. It is also possible to operate the iPod from the main unit or remote control unit.

Made for iPod iPod is a trademark of Apple Inc., registered in the U.S. and other countries.

※ The iPod may only be used to copy or play contents that are not copyrighted or contents for which copying or playback is legally permitted for your private use as an individual. Be sure to comply with applicable copyright legislation.

NOTE

- DENON will accept no responsibility whatsoever for any loss of iPod data.
- Depending on the type of iPod and the software version, some functions may not operate.

Listening to Music

- 1 Load the iPod on the set.
 - 2 Either turn <Multi Jog> or press <<< >>> after pressing <SOURCE> to select "iPod" then press ENTER, or press [iPod].
 - 3 Press >|||. Playback starts.
- ※ Also read the iPod's operating instructions.
 ※ Press ENTER during play to change to Artist display or Album display.



The mode switches between iPod remote mode and iPod browse mode each time [iPod] is pressed.

Repeat and Random Playback

□ REMOTE mode:

Repeat playback

Control with the iPod main unit.

Random playback

Control with the iPod main unit.

□ BROWSE mode:

Repeat playback

① Press [PLAY MODE].

② Either turn <Multi Jog> or press [Δ ∇] to select "Repeat".

③ Press ENTER to switch the repeat mode between "Off", "Repeat 1" and "Repeat All".

Random playback

① Either turn <Multi Jog> or press [Δ ∇] to select "Random".

② Press ENTER to switch the random mode between "Off", "Song" and "Album".

Remote control and iPod Button Relations

Remote control unit buttons	iPod buttons	Operation on the S-32
>	>	Play the track/Pause the track. ※ Play/Pause in remote mode
<<< >>>	<<< >>>	Play the track from the beginning/ Play the next track.
	<<< >>>	Fast-reverse the track/Fast-forward the track.
Δ, ∇	Click Wheel	Select an item.
ENTER	Select	Enter the selection or plays the track.
iPod	-	Switch between the browse mode and the remote mode.
PLAY MODE	-	Switch the repeat function. Switch the random function. (Browse mode only)

About the button names in these explanations

- < > : Buttons on the main unit
- [] : Buttons on the remote control unit

Button name only:

Buttons on the main unit and remote control unit

Listening to FM/AM



Tuning in Broadcast Stations

- 1 Either turn <Multi Jog> or press **|◀◀ ▶▶|** after pressing <SOURCE> to select “FM or AM” then press **ENTER**, or press **[FM/AM]**.

※ The display changes as follows each time you press a remote control button.

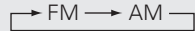

- 2 Press **|◀◀ ▶▶|** to select the reception frequency.

[To tune in automatically (Auto Tuning)]

- 1 Press **[PLAY MODE]**.
- 2 Either turn <Multi Jog> or press **[△▽]** to select “Mode”, then press **ENTER**.
- 3 Either turn <Multi Jog> or press **[△▽]** to select “Auto”, then press **ENTER**.

Auto :

Tuning stops once a broadcast is found.

[To tune in manually (Manual Tuning)]

- 1 Press **[PLAY MODE]**.
- 2 Either turn <Multi Jog> or press **[△▽]** to select “Mode”, then press **ENTER**.
- 3 Either turn <Multi Jog> or press **[△▽]** to select “Manual”, then press **ENTER**.

Automatically Presetting FM Stations (Auto preset)

- 1 Either turn <Multi Jog> or press **|◀◀ ▶▶|** after pressing <SOURCE> to select “FM” then press **ENTER**.
- 2 Press **[PLAY MODE]**.
- 3 Either turn <Multi Jog> or press **[△▽]** to select “Auto Preset”, then press **ENTER**.
Scanning starts and broadcast stations are automatically preset.
- 4 Either turn <Multi Jog> or press **[△▽]** to select “Start”, then press **ENTER**.

※ Press **RETURN** to stop the auto preset operation before it is finished.

Presetting Radio Stations (Preset Memory)

Your favorite broadcast stations can be preset so that you can tune them in easily. Up to 56 stations can be preset.

- 1 Tune in the broadcast station you want to preset.
- 2 Press **[PRESET FM/AM]**.
- 3 Either turn <Multi Jog> or press **[△▽]** to select “Add to Preset”, then press **ENTER**.
Select a number that has not be registered automatically and display it.
- 4 Either turn <Multi Jog> or press **[△▽]** to choose the number to be registered, then press **ENTER**.

NOTE

Preset stations are erased by overwriting them.



To preset other stations, repeat steps 1 to 4.

Naming Preset Broadcast Stations

Names can be registered for AM analog broadcast stations only. Up to 8 characters can be input.

- 1 Press **[PRESET FM/AM]** to select “Add to Preset”, then press **ENTER**.
- 2 Either turn <Multi Jog> or press **[△▽]** to choose the number to be registered.
- 3 Press and hold in **ENTER** for at least 2 seconds.
- 4 Either turn <Multi Jog> or press **[△▽]** to choose the letter to be inserted.
- 5 Use **|◀◀ ▶▶|** to choose the cursor position.
- 6 Once you are finished inputting, press **ENTER**.

Listening to Preset Stations

- 1 Press **[PRESET FM/AM]**.
- 2 Either turn <Multi Jog> or press **[△▽]** or **|◀◀ ▶▶|** to choose the station to be registered, then press **ENTER**.

※ Press **[△▽]** to enable selection of the following preset numbers.



Press **|◀◀ ▶▶|** to enable selection of the following preset numbers.



Listening to FM/AM Stations Registered Your Favorites

FM/AM stations can be stored in the favorites and played.
“Favorite” (📌 page 19)

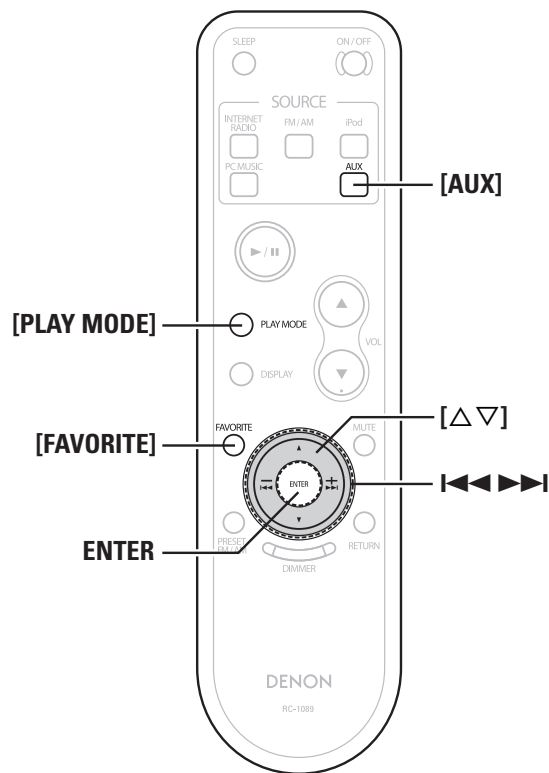
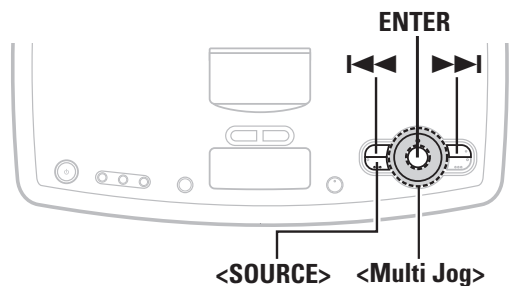

About the button names in these explanations
 < > : Buttons on the main unit
 [] : Buttons on the remote control unit
Button name only:
 Buttons on the main unit and remote control unit

RDS (Radio Data System)

RDS (works only on the FM band) is a broadcasting service which allows a station to send additional information along with the regular radio program signal. The following three types of RDS information can be received with this unit:

- Viewing track information during reception**
 Press **ENTER** while receiving a RDS to display the information of the track currently being broadcast.
 Either turn **<Multi Jog>** or press [Δ∇] to select the information.
 - Canceling track information**
 Press **ENTER** again to return to the previous display.
- ※ Information is only displayed when it is available.

Program Type (PTY)

PTY identifies the type of RDS program. The program types and their displays are as follows:

NEWS	News	WEATHER	Weather
AFFAIRS	Current Affairs	FINANCE	Finance
INFO	Information	CHILDREN	Children's programmes
SPORT	Sports	SOCIAL	Social Affairs
EDUCATE	Education	RELIGION	Religion
DRAMA	Drama	PHONE IN	Phone In
CULTURE	Culture	TRAVEL	Travel
SCIENCE	Science	LEISURE	Leisure
VARIED	Varied	JAZZ	Jazz Music
POP M	Pop Music	COUNTRY	Country Music
ROCK M	Rock Music	NATION M	National Music
EASY M	Easy Listening Music	OLDIES	Oldies Music
LIGHT M	Light Classical	FOLK M	Folk Music
CLASSICS	Serious Classical	DOCUMENT	Documentary
OTHER M	Other Music		

Traffic Program (TP)

TP identifies programs that carry traffic announcements. This allows you to easily find out the latest traffic conditions in your area before leaving home.

Radio Text (RT)

RT allows RDS stations to send text messages that appear on the display.

- When the station currently tuned in is offering a radio text message service, the message appear on the display.
- When the RT mode is turned on while an RDS radio station not offering an RT service is tuned in, "NO TEXT" is displayed on the display, then the mode automatically switches to the PS mode.
- In the same way, the mode automatically switches to the PS mode when the RT service is finished. In this case, the mode automatically switches from the PS mode back to the RT mode when an RT broadcast is resumed.
- The RT mode cannot be set in the AM band or for FM stations not offering RDS broadcasts.

NOTE

The operations described below selecting "RDS Search" will not function in areas in which there are no RDS broadcasts.

RDS Search

Use this function to automatically tune to FM stations that provide the RDS service.

- 1 Set the band to "FM", then press [PLAY MODE].**
 - 2 Either turn <Multi Jog> or press [Δ∇] to select "RDS Search", then press ENTER.**
 Automatically begin the RDS search operation.
- ※ If no RDS station is found, "NO PROGRAM" is displayed.

PTY Search

Use this function to find RDS stations broadcasting a designated program type (PTY).
For a description of each program type, refer to "Program Type (PTY)".

- 1 Set the band to "FM", then press [PLAY MODE].
- 2 Either turn <Multi Jog> or press [$\Delta \nabla$] to select "PTY Search", then press ENTER.
- 3 Either turn <Multi Jog> or press [$\Delta \nabla$] to select "PTY", then press ENTER.
Automatically begin the PTY search operation.
* If no program of the specified type is found, "NO PROGRAM" is displayed.

TP Search

Use this function to find RDS stations broadcasting traffic programs (TP stations).

- 1 Set the band to "FM", then press [PLAY MODE].
- 2 Either turn <Multi Jog> or press [$\Delta \nabla$] to select "TP Search", then press ENTER.
Automatically begin the TP search operation.
* "NO PROGRAM" is displayed when there is no traffic information broadcast station.

Listening to AUX



Playing a Portable Audio

Your portable audio player can be connected to the S-32's AUX IN jack to play tracks on the portable audio player.

- 1 Either turn <Multi Jog> or press |◀◀ ▶▶| after pressing <SOURCE> to select "AUX" then press ENTER, or press [AUX].
- 2 Play the portable audio player.
The Portable Audio are output.
* Also read the portable audio player's operating instructions.

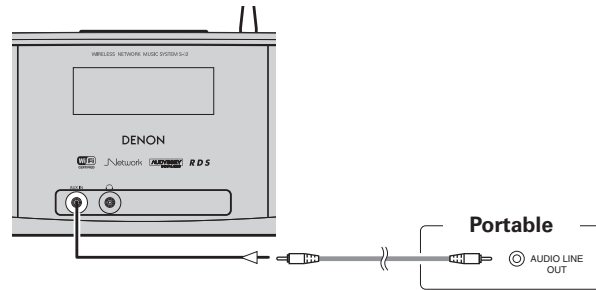

Connect the S-32 and portable audio player using a separately sold mini-stereo audio cable.

Favorite



Your favorite Internet radio stations, PC Music and broadcast stations can be registered in your favorites so that you can tune them in easily. Up to 50 data can be registered.

Registering Radio Stations and PC Music as Your Favorites

- 1 Press [FAVORITE] while the radio station or PC music you want to register is playing.
- 2 Either turn <Multi Jog> or press [$\Delta \nabla$] to select "Add to Favorite", then press ENTER.
"Complete!!" is displayed once registration is finished.



Press and hold in [FAVORITE] for at least 1 second to store in "Favorite".

NOTE

If more than 50 stations are already registered, the oldest data is deleted.

Listening to Radio Stations and PC Music Registered in Your Favorites

- 1 Press [FAVORITE].
- 2 Either turn <Multi Jog> or press [$\Delta \nabla$] to choose the radio station or PC Music to be registered, then press ENTER.

Advanced Operation

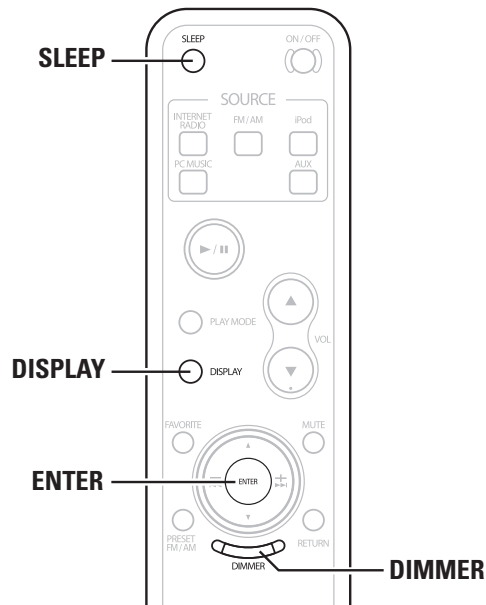
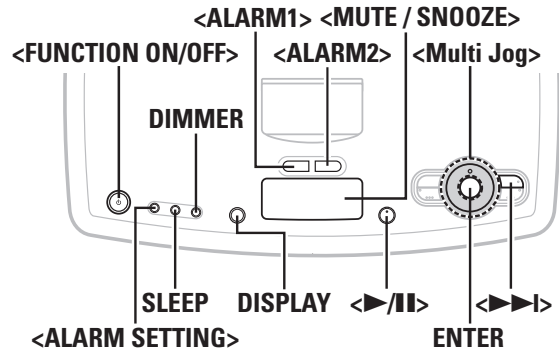

About the button names in these explanations

- < > : Buttons on the main unit
- [] : Buttons on the remote control unit

Button name only:

Buttons on the main unit and remote control unit

Alarm Setting

Set the alarm time, source and volume.

- 1** Press **<ALARM SETTING>** to set the alarm.
- 2** [Alarm number selection]
Turn **<Multi Jog>** to select “ALARM1” or “ALARM2”, then press **ENTER**.
The time display flashes.
- 3** [Alarm time setting]
Select time with **<Multi Jog>**, then press **ENTER** to set.
※ Turn **<Multi Jog>** clockwise to increment the set value, and counter-clockwise to decrement it.
- 4** [Alarm source setting]
Select alarm source with **<Multi Jog>**, then press **ENTER** to set.
- 5** [Alarm volume level setting]
Select alarm volume level with **<Multi Jog>**, and press **ENTER** to set.
- 6** Press **<ALARM1>** or **<ALARM2>**, and set the alarm on.



- When the input source is iPod or PC Music, if music does not play when the alarm on time is reached, a Beep will sound.
- Alarms 1 and 2 operate separately.
- If the set is not operated for 60 minutes after alarm playback starts, playback stops and the power turns off (The Beep sound stops after 5 minutes).
- When you want alarm playback of an iPod recording, set iPod while pausing the track you want to play.

Pausing alarm playback (snooze function)

Press **<MUTE / SNOOZE>** during alarm playback.
Alarm playback resumes 5 minutes after it was stopped.

Stopping alarm playback

Either press **<ALARM1>** or **<ALARM2>** on the main unit to turn the alarm off, or press the main unit's **<FUNCTION ON/OFF>**.

If there is a power failure

When connected to a network

When the power comes back on, the set automatically connects to an SNTP (Simple Network Time Protocol) server and the current time is adjusted automatically. Once the zone, daylight saving time and alarm time have been set, they are stored in the memory, so there is no need to set them again.

When unconnected to a network

When the power comes back on, the clock resumes from the time the power turned off. If the time is way off, turn the power on and reset the current time. If the alarm time has been set, it is stored in the memory, so there is no need to set it again.

Setting the Sleep Timer

Use this function to automatically switch the power to the standby mode after a specific amount of time (minutes).

1 Set the current time (☞ page 8).

2 During playback, use **SLEEP** to select the time.

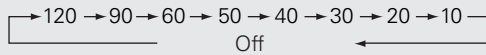

※ After about 5 seconds, the previous display reappears and the timer starts.

3 The power is set to the standby mode after the set amount of time.

Canceling the sleep timer

Press **SLEEP**, select "Off" from the sleep timer time display.

Checking the time remaining until the sleep timer starts

Press **SLEEP**.

Checking the current time

Press **DISPLAY** or hold down **DIMMER** for 2 seconds or more.

The time is displayed.

Convenient Functions

Personal Memory Plus Function

This function sets the settings last selected for the individual input sources.

When you switch to an input source, the settings are automatically set to the ones that were set the last time that input source was used.

Last Function Memory

This stores the settings as they were directly before the standby mode was set.

When the power is turned back on, the settings are restored to as they were directly before the standby mode was set.

Backup Memory

The various settings are backed up for about 1 week, even if the power is turned off or the power cord is disconnected.

Auto Power On

When the power is in the standby mode, the power turns on simply by pressing <▶/||>.

Resetting the Microprocessor

Perform this procedure if the display is abnormal or if operations cannot be performed.

When the microprocessor is reset, all the settings are reset to their default values.

1 Remove the power plug.

2 While pressing <▶▶▶> and <MUTE / SNOOZE> simultaneously, plug the power cord into a power outlet.

3 When "INITIALIZE" is displayed, release your fingers from the two buttons.



When "INITIALIZE" is not displayed in step 3, repeat operations from step 1.

Other Information

Audyssey Dynamic EQ.

Audyssey Dynamic EQ. is a technology that automatically corrects the tonal balance of an audio system when the volume is changed. It is based on psychoacoustic research that better matches to human perception than other loudness compensation that was used before. The tonal balance is adjusted continuously with variation in both program material and volume setting.

Audyssey BassXT

Audyssey BassXT is a solution to extend bass performance to lower frequencies without increasing cabinet size, driver size or weight. BassXT actively monitors the incoming low frequency signal and drives subwoofers to their maximum capability at all volumes, thereby producing deeper bass at all volume levels. This allows the subwoofer to play low bass content when it can and protects it only for the few times when it can't. It is not like simple bass boost or tone control as the system is fully customized for each speaker design by DSP processing and works in real time.

Manufactured under license from Audyssey Laboratories, Inc. U.S. and foreign patents pending.
Audyssey BassXT™ and Audyssey Dynamic EQ™ are trademarks of Audyssey Laboratories, Inc.

About Networks

Windows Media Player Ver.11

This is a media player distributed free of charge by Microsoft Corporation.

It can be used to play playlists created with Windows Media Player Ver. 11 as well as files in such formats as WMA, DRM WMA, MP3 and WAV.

vTuner

This is a free online contents server for Internet radio. Note that usage fees are included in upgrade costs.

For inquiries about this service, visit the vTuner site below.
vTuner website: <http://www.radiodenon.com>

This product is protected by certain intellectual property rights of Nothing Else Matters Software and BridgeCo. Use or distribution of such technology outside of this product is prohibited without a license from Nothing Else Matters Software and BridgeCo or an authorized subsidiary.

DLNA

- DLNA and DLNA CERTIFIED are trademarks and/or service marks of Digital Living Network Alliance.
- Some contents may not be compatible with other DLNA CERTIFIED™ products.

Windows Media DRM

A copyright-protected technology developed by Microsoft.

- Windows Vista and the Windows logo are trademarks of the Microsoft group of companies.
- The PlaysForSure logo, Windows Media and the Windows logo are trademarks or registered trademarks of Microsoft Corporation in the United States and/or other countries.
- Content providers are using the digital rights management technology for Windows Media contained in this device (WM-DRM) to protect the integrity of their content (Secure Content) so that their intellectual property, including copyright, in such content is not misappropriated. This device uses WM-DRM software to play Secure Content (WM-DRM Software). If the security of the WM-DRM Software in this device has been compromised, owners of Secure Content (Secure Content Owners) may request that Microsoft revoke the WM-DRM Software's right to acquire new licenses to copy, display and/or play Secure Content. Revocation does not alter the WM-DRM Software's ability to play unprotected content. A list of revoked WM-DRM Software is sent to your device whenever you download a license for Secure Content from the Internet or from a PC. Microsoft may, in conjunction with such license, also download revocation list onto your device on behalf of Secure Content Owners.

About Wireless LAN

Wi-Fi®

Wi-Fi Certification assures tested and proven interoperability by the Wi-Fi Alliance, a group certifying interoperability among wireless LAN devices.

IEEE 802.11b

This is one wireless LAN standard set by the 802 working group that establishes LAN technology standards at the IEEE (Institute of Electrical and Electronics Engineers) of the United States. It uses the 2.4 GHz band usable freely without a radio frequency license (ISM band), enabling communications at a maximum speed of 11 Mbps.



The value indicated above is the maximum theoretical value for the wireless LAN standard, and does not indicate the actual data transfer rate.

IEEE 802.11g

This is another wireless LAN standard set by the 802 working group that establishes LAN technology standards at the IEEE (Institute of Electrical and Electronics Engineers) of the United States, and is compatible with IEEE 802.11b. It also uses the 2.4 GHz band, but enables communications at a maximum speed of 54 Mbps.



The value indicated above is the maximum theoretical value for the wireless LAN standard, and does not indicate the actual data transfer rate.

Infrastructure Communications

“Infrastructure Communications” refers to networks using wireless LAN access points.

This function can be used to connect to the Internet or a wired LAN via a wireless LAN access point. Wireless LAN access points include wireless broadband routers.

Ad-hoc Communications

Signal transfer through wireless interconnection of computers is referred to as “ad hoc communications.” With such ad hoc communications there is no connection to the Internet. Ad hoc communications are suited for establishing simple temporary networks.

Network Names (SSID: Security Set Identifier)

When forming wireless LAN networks, groups are formed to prevent interference, data theft, etc. This grouping is done by “SSID” or “Security Set Identifiers.” For further security, a WEP key is set and signal transfer is not possible unless the SSID and WEP key match.

WEP Key (Network Key)

This is key information used for encrypting data when conducting data transfer. On the S-32, the same WEP key is used for data encryption and decryption, so the same WEP key must be set on both devices in order for communications to be established between them.

WPA (Wi-Fi Protected Access)

This is a security standard established by the Wi-Fi Alliance. In addition to the conventional SSID (network name) and WEP key (network key), it also uses a user identification function and encrypting protocol for stronger security.

WPA2 (Wi-Fi Protected Access 2)

This is a new version of the WPA established by the Wi-Fi Alliance, compatible with more secure AES encryption.

WPA-PSK/WPA2-PSK (Pre-shared Key)

This is a simple authentication system for mutual authentication when a preset character string matches on the wireless LAN access point and client.

Passphrase

This refers to the code key used for WPA-PSK/WPA2-PSK authentication, a WPA authentication method.

TKIP (Temporal Key Integrity Protocol)

This is a network key used for WPA. The encryption algorithm is RC4, the same as for WEP, but the security level is increased by changing the network key used for encryption for each packet.

AES (Advanced Encryption Standard)

This is a next generation standard encryption method replacing the current DES and 3DES, and because of its high security it is expected to be applied widely to wireless LANs in the future. It uses the “Rijndael” algorithm developed by two Belgian cryptographers to divide the data into blocks of fixed lengths and encrypt each block. It supports data lengths of 128, 192 and 256 bits and key lengths of 128, 192 and 256 bits as well, offering extremely high encryption security.

Troubleshooting

If a problem should arise, first check the following:

1. Are the connections correct?
2. Is the set being operated as described in the owner's manual?
3. Are the other components operating properly?

If this unit does not operate properly, check the items listed in the table below. Should the problem persist, there may be a malfunction.

In this case, disconnect the power immediately and contact your store of purchase.

[General]

Symptom	Cause	Countermeasure	Page
Display not lit and sound not produced when power switch set to on.	<ul style="list-style-type: none"> • Power cord not plugged in securely. 	<ul style="list-style-type: none"> • Plug the power cord into the wall power outlet. 	7
Display lit but sound not produced.	<ul style="list-style-type: none"> • Device you want to play and set input source do not match. • Volume control set to minimum. • MUTING is on. 	<ul style="list-style-type: none"> • Select an appropriate input source. • Turn volume up to suitable level. • Switch off MUTING. 	12 12 12
Display is dim.	<ul style="list-style-type: none"> • Dimmer function is on. 	<ul style="list-style-type: none"> • Turn the dimmer function off by pressing the DIMMER button. 	13

[Remote Control Unit]

Symptom	Cause	Countermeasure	Page
Set does not work properly when remote control unit operated.	<ul style="list-style-type: none"> • Batteries are worn. 	<ul style="list-style-type: none"> • Replace with new batteries. 	2
	<ul style="list-style-type: none"> • You are operating outside of the specified range. 	<ul style="list-style-type: none"> • Operate within the specified range. 	2
	<ul style="list-style-type: none"> • Obstacle between main unit and remote control unit. 	<ul style="list-style-type: none"> • Remove the obstacle. 	2
	<ul style="list-style-type: none"> • The batteries are not inserted in the proper direction, as indicated by the polarity marks in the battery compartment. 	<ul style="list-style-type: none"> • Insert the batteries in the proper direction, following the polarity marks in the battery compartment. 	2
	<ul style="list-style-type: none"> • The set's remote control sensor is exposed to strong light (direct sunlight, inverter type fluorescent bulb light, etc.). 	<ul style="list-style-type: none"> • Move the set to a place in which the remote control sensor will not be exposed to strong light. 	2

[iPod]

Symptom	Cause	Countermeasure	Page
iPod cannot be played.	<ul style="list-style-type: none"> • Input source is not right. 	<ul style="list-style-type: none"> • Select an appropriate input source. 	16
	<ul style="list-style-type: none"> • iPod is not properly mounted in dock for ipod. 	<ul style="list-style-type: none"> • Remount the iPod. 	5

[NET]

Symptom	Cause	Countermeasure	Page
The file names are not displayed properly (".;" etc.).	<ul style="list-style-type: none"> • Characters that cannot be displayed are used. 	<ul style="list-style-type: none"> • This is not a malfunction. On this set, characters that cannot be displayed are replaced with a ". (period)". 	-
Files stored on a computer cannot be played.	<ul style="list-style-type: none"> • Files are stored in a non-compatible format. 	<ul style="list-style-type: none"> • Record in a compatible format. 	13
	<ul style="list-style-type: none"> • You are attempting to play a file that is copyright protected. 	<ul style="list-style-type: none"> • Files that are copyright protected cannot be played on this set. 	13
Internet radio cannot be played.	<ul style="list-style-type: none"> • Ethernet cable is not properly connected or network is disconnected. 	<ul style="list-style-type: none"> • Check the connection status. 	6
	<ul style="list-style-type: none"> • Program is being broadcast in non-compatible format. 	<ul style="list-style-type: none"> • Only Internet radio programs in MP3 and WMA can be played on this set. 	-
	<ul style="list-style-type: none"> • The computer's or router's firewall is activated. 	<ul style="list-style-type: none"> • Check the computer's or router's firewall settings. 	-
	<ul style="list-style-type: none"> • Radio station is not currently broadcasting. • IP address is wrong. 	<ul style="list-style-type: none"> • Choose a radio station that is currently broadcasting. • Check the set's IP address. 	14 9, 10
Server is not found, or it is not possible to connect to the server.	<ul style="list-style-type: none"> • The computer's or router's firewall is activated. 	<ul style="list-style-type: none"> • Check the computer's or router's firewall settings. 	-
	<ul style="list-style-type: none"> • Computer's power is not turned on. 	<ul style="list-style-type: none"> • Turn on the power. 	-
	<ul style="list-style-type: none"> • Server is not running. • Set's IP address is wrong. 	<ul style="list-style-type: none"> • Launch the server. • Check the set's IP address. 	- 9, 10
Cannot connect to preset or favorite radio stations.	<ul style="list-style-type: none"> • Radio station is not currently broadcasting. 	<ul style="list-style-type: none"> • Wait a while before trying again. 	-
	<ul style="list-style-type: none"> • Radio station is not currently in service. 	<ul style="list-style-type: none"> • It is not possible to connect to radio stations that are no longer in service. 	-

Symptom	Cause	Countermeasure	Page
For some radio stations, "Server Full" or "Connection Down" is displayed and station cannot be connected to.	<ul style="list-style-type: none"> Station is congested or not currently broadcasting. 	<ul style="list-style-type: none"> Wait a while before trying again. 	-
Sound is broken during playback.	<ul style="list-style-type: none"> Network's signal transfer speed is slow or communications lines or radio station is congested. 	<ul style="list-style-type: none"> This is not a malfunction. When playing broadcast data with a high bit rate, the sound may be broken, depending on the communications conditions. 	-
Sound quality is poor or played sound is noisy.	<ul style="list-style-type: none"> File being played has a low bit rate. 	<ul style="list-style-type: none"> This is not a malfunction. 	-

[Tuner]

Symptom	Cause	Countermeasure	Page
Continuous noise is heard when receiving FM programs	<ul style="list-style-type: none"> Antenna cable is not properly connected. 	<ul style="list-style-type: none"> Connect the antenna cable properly. Connect an outdoor antenna. 	5 5
Hissing or continuous noise is heard when receiving AM programs	<ul style="list-style-type: none"> This may be noise from a TV or interference from a radio station. 	<ul style="list-style-type: none"> Turn off the TV. Change the position and direction of the AM loop antenna. 	- -

[Wireless LAN]

Symptom	Cause	Countermeasure	Page
Cannot connect to network.	<ul style="list-style-type: none"> The settings of the SSID and network key (WEP) are incorrect. The reception is poor and the signals cannot be received. 	<ul style="list-style-type: none"> Match the network settings with the S-32's settings. 	6
		<ul style="list-style-type: none"> Shorten the distance from the wireless LAN's access point, remove any obstacles and otherwise improve visibility, then try reconnecting. Also install away from microwave ovens and the access points of other networks. 	-
Played sound is interrupted or sound cannot be played.	<ul style="list-style-type: none"> There are multiple networks and the usable channels overlap. 	<ul style="list-style-type: none"> Set the access point's channel settings away from the channels used for other networks. Alternatively, connect using a network cable. 	-
		<ul style="list-style-type: none"> Set the access point's channel settings away from the channels used for other networks. Alternatively, connect using a network cable. 	-

Specifications

Audio section

Power amplifier

Rated output: 10 W + 10 W (4 Ω/ohms, 1 kHz, T.H.D. 10 %)

Tuner section

Reception frequency range: FM: 87.50 MHz ~ 108.00 MHz AM: 522 kHz to 1611 kHz

Receiving sensitivity: FM: 1.5 μV/75 Ω/ohms AM: 20 μV

FM stereo separation: 35 dB (1 kHz)

Clock/Timer section

Clock method: Power line frequency synchronized method (± 30 seconds)

General

Power supply: AC 230 V, 50 Hz

Power consumption: 36 W

0.4 W (standby)

Maximum external dimensions: 360 (W) x 126 (H) x 226 (D) mm
(including system cable)

Weight: 6 kg

Remote control unit (RC-1089)

Remote control method: IR pulse method

Power supply: R03/AAA Type (two batteries)

Maximum external dimensions: 48.5 (W) x 185 (H) x 19 (D) mm

Weight: 105 g (Approx 6 oz) (including batteries)

Wireless LAN

Network type (wireless LAN standards): Conforming to IEEE 802.11b

Conforming to IEEE 802.11g

(Conforming to Wi-Fi®)*

Transfer rate: DS-SS: 11 / 5.5 / 2 / 1 Mbps (Automatic switching)

OFDM: 54 / 48 / 36 / 24 / 18 / 12 / 9 / 6 Mbps (Automatic switching)

Security: SSID (Network name)

WEP key (network key) (64/128 bits)

WPA-PSK (TKIP/AES)

WPA2-PSK (TKIP/AES)

Used frequency range: 2,412 MHz ~ 2,462 MHz

No. of channels: Conforming to IEEE 802.11b : 13 ch (DS-SS) (Of which 1 channel used)

Conforming to IEEE 802.11g : 13 ch (OFDM) (Of which 1 channel used)

* Wi-Fi® conformity indicates tested and proven interoperability by the "Wi-Fi Alliance", a group certifying interoperability among wireless LAN devices.

※ For purposes of improvement, specifications and design are subject to change without notice.

※ This product incorporates copyright protection technology that is protected by method claims of certain U.S. patents and other intellectual property rights owned by Macrovision Corporation and other rights owners. Use of this copyright protection technology must be authorized by Macrovision Corporation, and is intended for home and other limited viewing uses only unless otherwise authorized by Macrovision Corporation. Reverse engineering or disassembly is prohibited.



DENON

www.denon.com

Denon Brand Company, D&M Holdings Inc.
Printed in China 00D 511 4692 008

Free Manuals Download Website

<http://myh66.com>

<http://usermanuals.us>

<http://www.somanuals.com>

<http://www.4manuals.cc>

<http://www.manual-lib.com>

<http://www.404manual.com>

<http://www.luxmanual.com>

<http://aubethermostatmanual.com>

Golf course search by state

<http://golfingnear.com>

Email search by domain

<http://emailbydomain.com>

Auto manuals search

<http://auto.somanuals.com>

TV manuals search

<http://tv.somanuals.com>