

Dell™ Photo All-In-One Printer 922

Owner's Manual

Look Inside For:

- Ordering Supplies
- Getting Started
- Using Your Printer
- Understanding the Software
- Maintenance and Troubleshooting



www.dell.com/supplies | support.dell.com

Ordering Ink Cartridges and Supplies

Your Dell™ Photo All-In-One Printer 922 includes software installed to detect the ink levels in the printer. During a print job, a screen appears on your computer to warn you of low ink levels. You can order ink online at www.dell.com/supplies or by phone.

US	877-INK-2-YOU	Italy	800602705
Australia	1300 303 290	Japan	044-556-3551
Austria	08 20 - 24 05 30 35	Luxembourg	02.713 1590
Belgium	02.713 1590	Mexico	001 866 851 1754
Canada	1-877-501-4803	Netherlands	020 - 674 4881
Chile	1230-020-3947	Norway	231622 64
	800-202874	Portugal	21 4220710
Colombia	01800-9-155676	PRC	800-858-0888
Denmark	3287 5215	Puerto Rico	866 851 1760
Finland	09 2533 1411	Spain	902120385
France	825387247	Sweden	08 587 705 81
Germany	0800 2873355	Switzerland	0848 801 888
Ireland	1850 707 407	UK	0870 907 4574

Your printer has been designed to print using the following ink cartridges.

Item:	Part number:
Black ink cartridge	M4640
Color ink cartridge	M4646
Photo ink cartridge	J4844
Standard yield black ink cartridge	J5566
Standard yield color ink cartridge	J5567

Notes, Notices, and Cautions



NOTE: A NOTE indicates important information that helps you make better use of your printer.



NOTICE: A NOTICE indicates either potential damage to hardware or loss of data and tells you how to avoid the problem.



CAUTION: A CAUTION indicates a potential for property damage, personal injury, or death.

Information in this document is subject to change without notice.

© 2004 Dell Inc. All rights reserved.

Reproduction in any manner whatsoever without the written permission of Dell Inc. is strictly forbidden.

Trademarks used in this text: *Dell*, the *DELL* logo, *Inspiron*, *Dell Precision*, *Dimension*, *OptiPlex*, and *Latitude* are trademarks of Dell Inc.; *Microsoft* and *Windows* are registered trademarks of Microsoft Corporation.

Other trademarks and trade names may be used in this document to refer to either the entities claiming the marks and names or their products. Dell Inc. disclaims any proprietary interest in trademarks and trade names other than its own.

UNITED STATES GOVERNMENT RESTRICTED RIGHTS

This software and documentation are provided with RESTRICTED RIGHTS. Use, duplication or disclosure by the Government is subject to restrictions as set forth in subparagraph (c)(1)(ii) of the Rights in Technical Data and Computer Software clause at DFARS 252.227-7013 and in applicable FAR provisions: Dell Inc., One Dell Way, Round Rock, Texas, 78682, USA.

Contents

1 Getting Started

Understanding the Printer Parts	12
Accessing Your <i>User's Guide</i>	14
Setting Up Your Printer	14
Using the Operator Panel	15
Operator Panel Menus	16
Understanding the Automatic Paper Type Sensor	17
Loading Paper	18
Print Media Guidelines for the Paper Support	19
Placing Your Document on the Scanner Glass	21

2 Using Your Printer

Printing	24
Printing a Document	24
Printing Photos	24
Printing Borderless Photos	25
Printing Other Projects	26
Copying	26
Copying Documents Using the Operator Panel	26
Copying Documents Using Your Computer	27
Copying Photos Using Your Computer	27
Copying Photos Without a Computer	28
Changing Copy Settings	28

Scanning	30
Scanning Photos	30
Scanning Multiple Pages or Images	31
Editing Scanned Text Using Optical Character Recognition (OCR)	31
Saving an Image on Your Computer	32
E-mailing a Scanned Image or Document	32
Enlarging or Reducing Images or Documents	33
Faxing	33
Sending a Fax	34
Installing Microsoft Fax in Windows XP	34
Configuring Microsoft Fax	35
Changing the Fax Configuration	36

3 Understanding the Software

Understanding the Printer Software	38
Using the Dell Printer Solution Center	38
Using the Dell All-In-One Center	39
Using Print Properties	40
Using Dell Picture Studio v2.0	41

4 Ink Cartridge Maintenance

Replacing Ink Cartridges	44
Aligning Ink Cartridges	47
Cleaning the Ink Cartridge Nozzles	48

5 Troubleshooting

Troubleshooting	52
Setup Problems	52
General Problems	55

Error Messages and Lights	57
Improving Print Quality	58
6 Contacting Dell	
Technical Assistance	62
Automated Order-Status Service	62
Contacting Dell	63
7 Appendix	
Limited Warranties and Return Policy	82
Limited Warranty for Dell-Branded Hardware Products (U.S. Only)	82
"Total Satisfaction" Return Policy (U.S. Only)	86
Limited Warranty Terms for Dell-Branded Hardware Products (Canada Only)	88
"Total Satisfaction" Return Policy (Canada Only)	92
Dell Software and Peripherals (Canada Only)	93
1-Year End-User Manufacturer Guarantee (Latin America and the Caribbean Only)	94
Dell Inc. Ink and Toner Cartridges Limited Warranties	97
Ink and Toner Cartridges Limited Warranty (U.S. and Canada Only)	97
Ink and Toner Cartridges Limited Warranty (Latin America Only)	98
Dell Software License Agreement	99
Regulatory Notices	102
NOM Information (Mexico Only)	102
Index	105

CAUTION: SAFETY INSTRUCTIONS

Use the following safety guidelines to help ensure your own personal safety and to help protect your computer and working environment from potential damage.

- Use only the power cable provided with this product or the manufacturer's authorized replacement power cable.
- Connect the power cable to an electrical outlet that is near the product and easily accessible.
- Refer service or repairs, other than those described in the user documentation, to a professional service person.

 **CAUTION: Do not use the fax feature during a lightning storm. Do not set up this product or make any electrical or cabling connections, such as the power cable or telephone, during a lightning storm.**

SECTION 1

Getting Started

Understanding the Printer Parts

Accessing Your User's Guide

Setting Up Your Printer

Using the Operator Panel

Understanding the Automatic Paper Type Sensor

Loading Paper

Understanding the Printer Parts

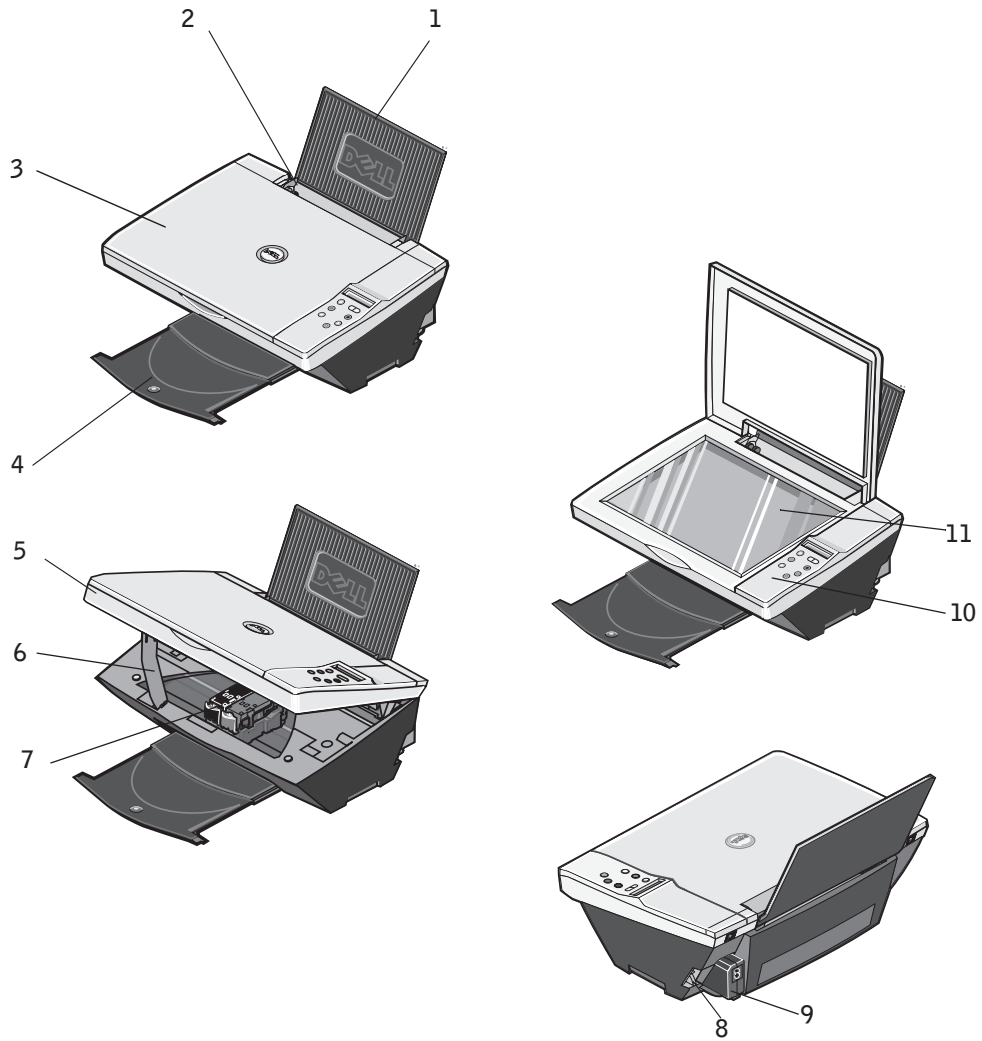

Number:	Part:	Description:
1	Paper support	Part that supports loaded paper.
2	Paper guide	Guide that helps the paper feed into the printer properly.

Number:	Part:	Description:
3	Top cover	Top of printer that holds your document or photo flat while you scan it.
4	Paper exit tray	Tray that holds the paper as it exits the printer. NOTE: Pull the paper exit tray straight out to extend it.
5	Printer unit	Unit you lift to gain access to the ink cartridges.
6	Scanner support	Part under printer unit that keeps the printer open while you change ink cartridges. NOTE: To close the printer for normal operation, lift the printer unit, press the scanner support to the right, and then lower the printer unit until it rests on the main body of the printer.
7	Ink cartridge carrier	Carrier that holds two ink cartridges, one color and the other black or photo (sold separately). For more information on your cartridges, see "Replacing Ink Cartridges" on page 44.
8	USB connector	Slot into which you plug the USB cable (sold separately). The other end of the USB cable plugs into your computer.
9	Power connector	Slot into which you plug the power cable. NOTE: Insert the power cable into the printer before connecting the power cable into the wall outlet.
10	Operator panel	Panel on the printer you use to control copying, faxing, and printing. For more information, see "Using the Operator Panel" on page 15.
11	Scanner glass	Surface on which you place your document or photo face down to copy, fax, or scan it.

Accessing Your *User's Guide*

Click Start→Programs or All Programs →Dell Printers→Dell Photo AIO Printer 922→View Dell User's Guide.



NOTE: You cannot access your User's Guide until you have installed the drivers for your printer.

Setting Up Your Printer



NOTE: The Dell Photo AIO Printer 922 supports Microsoft® Windows® 2000 and Windows XP.

Follow the instructions on your printer *Setup Diagram* to install the hardware and software. If you encounter problems during setup, see "Troubleshooting" on page 51.

You can use the Dell Photo All-In-One Printer 922 to do a variety of things. A few important things to note:

- If your printer is connected to a computer, you can use either the printer operator panel or the printer software to create your projects.
- You *do* need to connect your printer to a computer to scan, print, and fax.
- You *do not* need to connect your printer to a computer to copy.

Using the Operator Panel

The operator panel buttons allow you to scan, copy, and customize documents. The printer is on when the **Power** button illuminates.

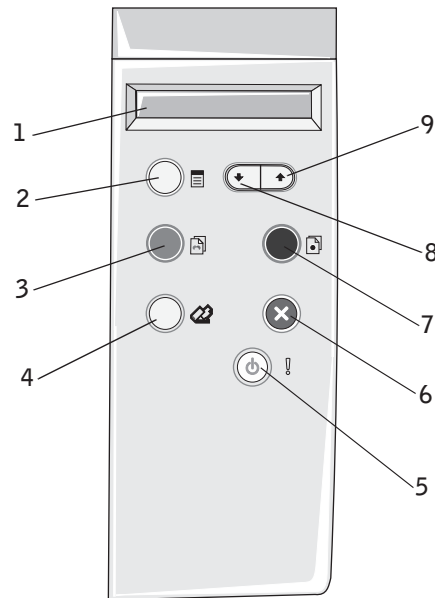

	Use the:	To:
1	Display	<ul style="list-style-type: none"> View the number of copies selected. View settings for Quality, Dark, and Resize. For more information, see "Operator Panel Menus" on page 16.
2	Menu button	<ul style="list-style-type: none"> Scroll through the available menus. Each time you press this button, the next item on the display appears. Select a choice that appears on the display. Feed newly loaded paper.
3	Color Copy button	Make a color copy.
4	Scan button	<p>Start the scanning process and open the Dell All-In-One Center (if your printer is connected to a computer).</p> <p>NOTE: If using your printer without a computer, this button does not function.</p>

	Use the:	To:
5	Power button	Turn your printer on or off.
6	Cancel button	<ul style="list-style-type: none"> • Cancel a scan, print, or copy job in progress. • Cancel a copy job (using only the printer) and eject a page. • Exit a menu and return to the default settings.
7	Black Copy button	Make a black and white copy.
8	Down arrow button	<ul style="list-style-type: none"> • Decrease a number on the display. • Scroll through a list on the display.
9	Up arrow button	<ul style="list-style-type: none"> • Increase a number on the display. • Scroll through a list on the display.

Operator Panel Menus

When you press the **Menu** button, the following menus appear.

From this menu:	You can:
Copies	<ul style="list-style-type: none"> • Press the down arrow button to decrease the number of copies. • Press the up arrow button to increase the number of copies.
Quality	<p>Press the down arrow button or the up arrow button to select one of these quality settings.</p> <ul style="list-style-type: none"> • Draft (Do not select Draft if a photo cartridge is installed.) • Normal • Photo
Dark (Lighter/Darker)	<p>Make a document lighter or darker.</p> <ul style="list-style-type: none"> • Press the down arrow button to make a document lighter (in 25% increments). • Press the up arrow button to make a document darker (in 25% increments).
Resize	<p>Change the size of the image or document.</p> <ul style="list-style-type: none"> • Press the down arrow button to decrease the size of the image or document. • Press the up arrow button to increase the size of the image or document.

Understanding the Automatic Paper Type Sensor

Your printer has an automatic paper type sensor that detects the following paper types:

- Plain
- Transparency
- Glossy/photo
- Coated

If you load one of these paper types, the printer detects the paper type and automatically adjusts the **Quality/Speed** settings.

Paper type	Quality/Speed settings	
	Black and Color Cartridges Installed	Photo and Color Cartridges Installed
Plain	Normal	Photo
Transparency	Normal	Photo
Glossy/photo	Photo	Photo
Coated	Normal	Photo

 **NOTE:** Your printer cannot detect the paper size.

To choose paper size:

- 1 With your document open, click **File→Print**.
- 2 In the **Print** dialog box, click **Preferences** or **Properties** (depending on your program or operating system).
The **Print Properties** screen appears.
- 3 On the **Paper Setup** tab, select the paper size.
- 4 Click **OK**.

Unless you turn off the automatic paper type sensor, it always remains on. To turn off the automatic paper type sensor for a specific print job:

- 1 With your document open, click **File→Print**.
- 2 In the **Print** dialog box, click **Preferences** or **Properties** (depending on your program or operating system).

The **Printing Preferences** screen appears.

- 3 Click the **Quality/Copies** tab.
- 4 Click the **Use my choice** button.
- 5 Select the paper type in the drop-down menu.
- 6 Click **OK**.

To turn off the automatic paper type sensor for all print jobs:

- 1 In *Windows XP*, click **Start**→**Control Panel**→**Printers and Other Hardware**→**Printers and Faxes**.
In *Windows 2000*, click **Start**→**Settings**→**Printers**.
- 2 Right-click the **Printer** icon.
- 3 Click **Printing Preferences**.
- 4 Click the **Quality/Copies** tab, and then click **Paper Type Sensor Options**.
- 5 Click the **Use my choice** button.
- 6 Select the paper type in the drop-down menu.
- 7 Click **OK**.

Loading Paper

- 1 Place the paper against the guide on the right side of the paper support.
- 2 Squeeze and slide the left paper guide to the left edge of the paper.

 **NOTE:** Do not force paper into the printer. The paper should be flat against the paper support surface and the right edge should be flush against the right paper guide.

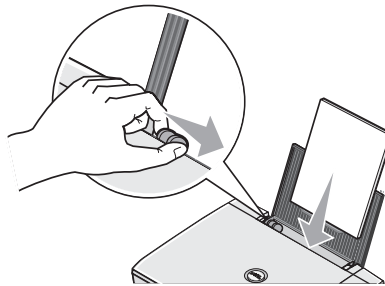

Print Media Guidelines for the Paper Support

Load up to:	Make sure:
100 sheets of plain paper	<ul style="list-style-type: none">• The paper is loaded vertically against the right side of the paper support.• The paper guide rests against the left edge of the paper. <p>NOTE: Load letterhead paper with the top of the letterhead entering the printer first and facing up.</p> <ul style="list-style-type: none">• You select Draft (select Photo if a photo cartridge is installed), Normal, or Photo print quality.
20 sheets of banner paper	<ul style="list-style-type: none">• You remove any paper from the paper support before inserting banner paper.• You place a stack of banner paper on or behind the printer, with only the number of sheets required. <p>NOTE: You must select A4 Banner or Letter Banner paper size in Print Properties. Failure to do so will cause a paper jam. See "Paper Problems" on page 55.</p> <ul style="list-style-type: none">• You load the leading edge of the banner paper into the printer against the right side of the paper support.• You squeeze and slide the paper guide to the left edge of the banner paper.• You use banner paper designed for inkjet printers.

Load up to:	Make sure:
10 envelopes	<ul style="list-style-type: none"> • The print side of the envelopes faces up. • The envelopes are loaded vertically against the right side of the paper support. • The stamp location is in the upper left corner.
<ul style="list-style-type: none"> • The paper guide rests against the left edge of the envelopes. • You print the envelopes with Landscape orientation. • You select the correct envelope size. Select the next biggest size if the exact envelope size is not listed, and set the left and right margins so that your envelope text will be correctly positioned. 	
<p>NOTE: You can load a single envelope into the paper support without removing plain paper.</p>	
25 greeting cards, index cards, postcards, or photo cards	<ul style="list-style-type: none"> • The print side of the cards faces up. • The cards are loaded vertically against the right side of the paper support. • The paper guide rests against the left edge of the cards. • You select Normal or Photo print quality.
25 sheets of photo or glossy paper	<ul style="list-style-type: none"> • The glossy or coated side of the paper faces up. • The paper guide rests against the left edge of the paper. • You select Normal or Photo print quality. • The paper is loaded vertically against the right side of the paper support.
1 iron-on transfer	<ul style="list-style-type: none"> • You follow the loading instructions on the packaging. • The blank side of the transfer faces up. • The paper guide rests against the left edge of the transfer. • You select Normal or Photo print quality.

Load up to:

20
transparencies

Make sure:

- The rough side of the transparencies faces up.
- The paper guide rests against the left edge of the transparencies.

NOTE: You can load a single transparency into the paper support without removing plain paper.

- You select **Normal** or **Photo** print quality.
 - The transparencies are loaded vertically against the right side of the paper support.
-

Placing Your Document on the Scanner Glass

- 1 Open the top cover.

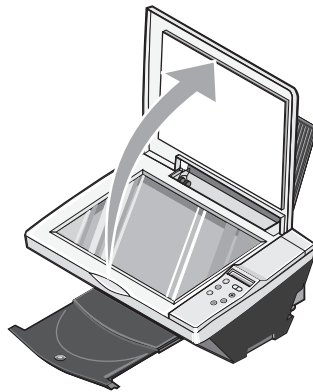

- 2 Place the item you want to copy face down on the scanner glass in the lower right corner.

 **NOTE:** Make sure the upper left corner of the front of the item aligns with the arrow on the printer.

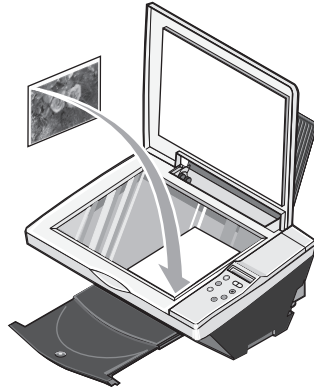

3 Close the top cover.

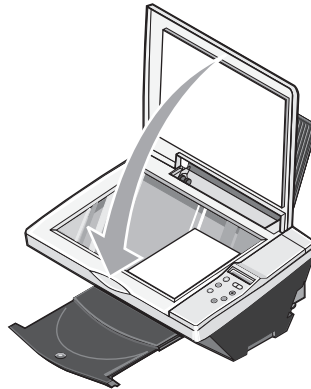

SECTION 2

Using Your Printer

Printing

Copying

Scanning

Faxing

Printing

Printing a Document

- 1 Turn on your computer and printer, and make sure they are connected.
- 2 Load paper with the print side facing up. For more information, see "Loading Paper" on page 18.
- 3 With your document open, click **File→Print**.
- 4 Customize your print settings:
 - a Click **Preferences, Properties, Options, or Setup** (depending on the program or operating system).

The **Print Properties** dialog box appears.
 - b On the **Quality/Copies** tab, select **Quality/Speed**, the paper type, the number of copies, and black and white or color printing.
 - c On the **Paper Setup** tab, select the paper size and orientation.
 - d On the **Print Layout** tab, select the layout and duplexing settings.
 - e To see details about a setting, right-click the setting on the screen, and then select **What's This?**.
 - f After making the changes in **Print Properties**, click **OK** at the bottom of the screen to return to the **Print** dialog box.
- 5 Click **OK** or **Print** (depending on the program or operating system).

Printing Photos

- 1 Load the photo paper with the print (glossy) side facing up. For more information, see "Print Media Guidelines for the Paper Support" on page 19.
- 2 Make sure you have a color cartridge and a photo cartridge (sold separately) installed. For more information, see "Replacing Ink Cartridges" on page 44.
- 3 With your document open, click **File→Print**.
- 4 To customize your print settings, click **Preferences, Properties, Options, or Setup** (depending on the program or operating system).

The **Print Properties** dialog box appears.
- 5 On the **Quality/Copies** tab, select **Photo** and the paper type.

6 On the **Paper Setup** tab, select the paper size and orientation.

 **NOTE:** Photo/glossy or coated paper is recommended for printing photos.

7 On the **Print Layout** tab, select the photo layout.

8 When finished customizing your photo, click **OK**.

9 Click **OK** or **Print** (depending on the program or operating system).

10 To prevent your photos from sticking together or smudging, remove each photo after it exits the printer.

 **NOTE:** Before placing your prints in a nonadhesive photo album or frame, allow sufficient time for the prints to dry thoroughly (12 to 24 hours, depending on the ambient conditions). This maximizes the life of your prints.

Printing Borderless Photos



1 For best results, load photo/glossy paper and make sure the print side is facing up. For more information, see "Print Media Guidelines for the Paper Support" on page 19.

2 Make sure you have a color cartridge and a photo cartridge installed.

3 With your document open, click **File**→**Print**.

4 To customize your print settings, click **Preferences**, **Properties**, **Options**, or **Setup** (depending on the program or operating system).

The **Print Properties** dialog box appears.

5 On the **Print Layout** tab, click **Borderless**.

6 When finished customizing your photo, click **OK**.

- 7 Click **OK** or **Print** (depending on the program or operating system).

Printing Other Projects

The **I Want To** menu provides wizards for creating projects. You may want to print a photo, print on an envelope, print a banner, make a poster, create a booklet, or print a greeting card.

- 1 With your document open, click **File**→**Print**.
- 2 To customize print settings, click **Preferences**, **Properties**, **Options**, or **Setup** (depending on the program or operating system).

The **Print Properties** dialog box appears along with the **I Want To** menu.

- 3 Select one of the available projects or click **See more printing ideas**.
- 4 Follow the instructions on the screen to complete your project.

Copying

To make copies, you can use the printer operator panel or your computer. For easy one-touch color or black and white copies, press **Color Copy** or **Black Copy** on the operator panel.

Copying Documents Using the Operator Panel

- 1 Turn on your printer.
- 2 Load the paper. For more information, see "Loading Paper" on page 18.
- 3 Open the top cover.
- 4 Place the item you want to copy face down on the scanner glass. Make sure the upper left corner of the front of the item aligns with the arrow on the printer. For more information, see "Placing Your Document on the Scanner Glass" on page 21.
- 5 Close the top cover.
- 6 If you want to make more than one copy, press the up arrow on the operator panel to select the number of copies (1-99).
- 7 Change any copy settings. For more information, see "Operator Panel Menus" on page 16.



NOTE: If you are using the Dell software on a computer instead of the operator panel buttons, see "Changing Copy Settings" on page 28.

- 8 On the operator panel, press the **Color Copy** button to create a color copy or press the **Black Copy** button to create a black and white copy.

Copying appears on the display.

Copying Documents Using Your Computer

- 1 Turn on your computer and printer, and make sure they are connected.
- 2 Load the paper. For more information, see "Loading Paper" on page 18.
- 3 Open the top cover.
- 4 Place your document on the scanner glass. Make sure the upper left corner of the front of the item aligns with the arrow on the printer. For more information, see "Placing Your Document on the Scanner Glass" on page 21.
- 5 Close the top cover.
- 6 Click **Start**→**Programs** or **All Programs** →**Dell Printers**→**Dell Photo AIO Printer 922**→**Dell All-In-One Center**.

The **Dell All-In-One Center** appears.

- 7 Select a copy quantity (1-99) and color.
- 8 Click **See More Copy Settings** to:
 - Choose a copy quality.
 - Select the blank paper size.
 - Select the original document size.
 - Lighten or darken your document.

Copying Photos Using Your Computer

- 1 Turn on your computer and printer, and make sure they are connected.
- 2 Load photo paper with the print side facing up. For more information, see "Print Media Guidelines for the Paper Support" on page 19.
- 3 Place your document face down on the scanner glass. Make sure the upper left corner of the front of the item aligns with the arrow on the printer. For more information, see "Placing Your Document on the Scanner Glass" on page 21.
- 4 Click **Start**→**Programs** or **All Programs** →**Dell Printers**→**Dell Photo AIO Printer 922**→**Dell All-In-One Center**.

The **Dell All-In-One Center** appears.

- 5 Click **Preview Now**.
- 6 Adjust the dotted lines to fit around the portion of the image you want to print.
- 7 In the **Copy** section, select **Photo**.
- 8 Select a copy quantity and color.
- 9 To customize your photo, click **See More Copy Settings**.
- 10 When you finish customizing your settings, click **Copy Now**.

Copying Photos Without a Computer

- 1 Load photo paper. For more information, see "Print Media Guidelines for the Paper Support" on page 19.
- 2 Open the top cover.
- 3 Place the photo on the glass.
- 4 Close the top cover.
- 5 Select the copy quality. For more information, see "Operator Panel Menus" on page 16.
- 6 Press the **Color Copy** button.

Changing Copy Settings

- 1 Click **Start**→**Programs** or **All Programs**→**Dell Printers**→**Dell Photo AIO Printer 922**→**Dell All-In-One Center**.

The **Dell All-In-One Center** appears.

- 2 Select a copy quantity and color.
- 3 Click **See More Copy Settings** to:
 - Choose a copy quality.
 - Select the blank paper size.
 - Select the original document size.
 - Lighten or darken your document.
 - Reduce or enlarge your document.
- 4 Click the **Advanced** button to change options such as paper size and quality.

5 To make any changes, click the following tabs.

Click this tab:	To:
Print	<ul style="list-style-type: none">• Select the paper size and type.• Select borderless printing options.• Select the print quality.
Scan	<ul style="list-style-type: none">• Select the color depth and scan resolution.• Auto-crop the scanned image.
Image Enhancements	<ul style="list-style-type: none">• Sharpen your blurry images.• Adjust the brightness of your image.• Adjust the color correction curve (gamma) of your image.
Image Patterns	<ul style="list-style-type: none">• Smooth the conversion of a gray image to a black and white dot pattern (dither).• Remove image patterns from magazines or newspapers (descreen).<ul style="list-style-type: none">– Select whether to process with Best quality or Best speed.• Reduce the background noise on your color document.

6 When you finish customizing your copy settings, click **OK**, and then click **Copy Now**.

Scanning

- 1 Turn on your computer and printer, and make sure they are connected.
- 2 Place the document face down on the scanner glass and make sure the upper left corner of the front of the document aligns with the arrow on the printer. For more information, see "Placing Your Document on the Scanner Glass" on page 21.
- 3 Press **Scan** on the operator panel.
The **Dell All-In-One Center** appears.
- 4 In the **Send scanned image to:** drop-down menu, select a program as your scan destination.
- 5 Customize your scan settings.
- 6 Click **Scan Now** to complete your scan.

Scanning Photos

- 1 Turn on your computer and printer, and make sure they are connected.
- 2 Place the photo face down on the scanner glass and make sure the upper left corner of the front of the photo aligns with the arrow on the printer. For more information, see "Placing Your Document on the Scanner Glass" on page 21.
- 3 Press **Scan** on the operator panel.
The **Dell All-In-One Center** appears.
- 4 Click **Preview Now**.
- 5 Adjust the dotted lines to fit around the portion of the photo you want to scan.
- 6 In the **Send scanned image to:** drop-down menu, select the photo program you want to use.



NOTE: If the program you want to use is not listed, select **Search for more...** in the drop-down menu. On the next screen, click **Add** to locate and add your program to the list.

- 7 Change any settings.
- 8 When you finish customizing your image, click **Scan Now**.

When your document has finished processing, the selected program opens.

Scanning Multiple Pages or Images

- 1 Place the first sheet on the scanner glass and make sure the upper left corner of the front of the sheet aligns with the arrow on the printer. For more information, see "Placing Your Document on the Scanner Glass" on page 21.
- 2 Click **Start**→**Programs** or **All Programs**→**Dell Printers**→**Dell Photo AIO Printer 922**→**Dell All-In-One Center**.
The **Dell All-In-One Center** appears.
- 3 In the **Send scanned image to:** drop-down menu, select the program you want to use. For example, you might want to fax or e-mail multiple pages to someone.
- 4 In the **Scan** section, click **See More Scan Settings**.
- 5 Click the **Advanced** button.
- 6 Click **Display Advanced Scan Settings** to change advanced options.
- 7 On the **Scan** tab, click the **Scan multiple items before output** box.
- 8 Click **OK**.
- 9 When you finish customizing your settings, click **Scan Now**.
After you scan the first page, a prompt appears requesting the next page.
- 10 Place the next sheet on the scanner glass and click **Yes**. Repeat until you finish scanning all pages.
- 11 When finished, click **No**. The program appears with the multiple pages scanned.

Editing Scanned Text Using Optical Character Recognition (OCR)

Optical Character Recognition (OCR) software converts a scanned image into editable text within a word processing program.

NOTE: Japanese customers should use E-Typist OCR software. This software is located on a separate CD.

- 1 Open the top cover.
- 2 Place your document on the scanner glass. Make sure the upper left corner of the front of the document aligns with the arrow on the printer. For more information, see "Placing Your Document on the Scanner Glass" on page 21.
- 3 Close the top cover.
- 4 Click **Start**→**Programs** or **All Programs**→**Dell Printers**→**Dell AIO Printer A922**→**Dell All-In-One Center**.

The **Dell All-In-One Center** appears.

- 5 In the **Send scanned images to:** drop-down menu, select a word processing or text-editing program.
- 6 In the **How will the scan be used?** drop-down menu, select **To edit text (OCR and 300 DPI)**.
- 7 Click **Scan Now**.

The scanned text appears.

Saving an Image on Your Computer

- 1 Click **Start**→**Programs** or **All Programs**→**Dell Printers**→**Dell Photo AIO Printer 922**→**Dell All-In-One Center**.

The **Dell All-In-One Center** appears.

- 2 In the **Creative Tasks** section, click **Save an image on my computer**.
- 3 Follow the instructions on your screen.

E-mailing a Scanned Image or Document

To send scanned images or documents through e-mail:

- 1 Open the top cover.
- 2 Place the photograph or document you want to scan face down on the scanner glass. Make sure the upper left corner of the front of the photograph or document aligns with the arrow on the printer. For more information, see "Placing Your Document on the Scanner Glass" on page 21.
- 3 Close the top cover.
- 4 Click **Start**→**Programs** or **All Programs**→**Dell Printers**→**Dell Photo AIO Printer 922**→**Dell All-In-One Center**.

The **Dell All-In-One Center** appears.

- 5 Click **Preview Now**.
- 6 In the **Creative Tasks** section, click **E-mail an image to a friend**.
- 7 In the **What is being scanned?** menu, make a selection.
- 8 Follow the instructions on the screen to prepare the photograph for e-mail.
- 9 Click **Next**.

- 10 Open your e-mail program, write a note to accompany the attached photo, and then send it.

NOTE: If you have questions about how to do this, consult the Help for your e-mail program.

Enlarging or Reducing Images or Documents

If you are using your printer *with* a computer, you can enlarge or reduce your document between 25-400 percent using the Dell All-In-One Center.

If you are using your printer *without* a computer, you can enlarge or reduce your document by: 25, 50, 100, 150, 200 percent, and Fit-to options using the operator panel.

- 1 Load the paper. For more information, see "Loading Paper" on page 18.
- 2 Place your document on the scanner glass. Make sure the upper left corner of the front of the document aligns with the arrow on the printer. For more information, see "Placing Your Document on the Scanner Glass" on page 21.
- 3 Click **Start**→**Programs** or **All Programs**→**Dell Printers**→**Dell Photo AIO Printer 922**→**Dell All-In-One Center**.

The **Dell All-In-One Center** appears.

- 4 Click **Preview Now**.
- 5 In the **Creative Tasks** section, select **Enlarge or reduce an image**.
- 6 Follow the instructions on the screen to select the size of your new image.
- 7 When you finish customizing your image, click **Print Now**.

Faxing

To use Microsoft Fax, you must have a Windows-based computer equipped with a modem. Before you do anything else, check to see that the Microsoft Fax software is on your computer:

Click **Start**→**Programs** or **All Programs**→**Accessories**→**Communications**.

For Windows XP:

- If you see Fax in the list that appears, you have Microsoft Fax on your computer. Continue with "Configuring Microsoft Fax" on page 35.
- If you do not see Fax in the list that appears, continue with "Installing Microsoft Fax in Windows XP" on page 34.

For Windows 2000, Fax Service Management is automatically installed.

Sending a Fax

You can send single or multiple page faxes.

- 1 Turn on your printer and computer, and make sure they are connected. Make sure your computer modem is connected to an active analog phone line. If you have DSL, you must have a DSL filter installed.
- 2 Place your document on the scanner glass and make sure the upper left corner aligns with the arrow. For more information, see "Placing Your Document on the Scanner Glass" on page 21.
- 3 Click **Start**→**Programs** or **All Programs**→**Dell Printers**→**Dell Photo AIO Printer 922**→**Dell All-In-One Center**.

The **Dell All-In-One Center** appears.

- 4 In the **Creative Tasks** section of the **Dell All-In-One Center** you can either:
 - Click **Fax an image** and follow the instructions on the screen.

NOTE: One of the questions on the screen asks if there is more than one page. If there are multiple pages in your fax, you should choose **Yes, prompt me for each page**.

- In the **Scan or Fax** section, customize your fax job by answering the questions that appear on your screen.
 - If you want to send a single page fax, click **Fax Now**.
 - If you want to send a multiple page fax, click **Advanced**→**Scan multiple items before output**→**OK**.

Installing Microsoft Fax in Windows XP

- 1 Click **Start** →**Settings** →**Control Panel**. Under **Pick a Category**, click **Add or Remove Programs**.

The **Add or Remove Programs** dialog box opens.

- 2 Click **Add/Remove Windows Components**.
- 3 In the **Components** list, click to select the **Fax Services** box.
- 4 Click **Next**.
- 5 Click **Finish**.
- 6 In the **Add or Remove Programs** dialog box, click **Close**.

Configuring Microsoft Fax

To configure for fax:

- 1 Click **Start** → **Programs** or **All Programs** → **Accessories** → **Communications** → **Fax** → **Fax Console** (Windows XP) and **Fax Service Management** (Windows 2000).
- 2 On the **Welcome to Fax Configuration** screen, click **Next**.
- 3 On the **Sender Information** screen, type the information you want to be displayed on your fax cover page, and then click **Next**.
- 4 On the **Select Device for Sending or Receiving Faxes** screen, click the modem that is installed in your computer in the **Please select the fax device** list.
- 5 If you want to disable the sending of faxes, click to clear the **Enable Send** check box.
- 6 Click the **Manual answer** button or **Automatically answer after** (user-defined number of rings) button.
- 7 Click to select the **Enable Receive** check box if you want to receive faxes.
- 8 Click **Next**.
- 9 On the **Transmitting Subscriber Identification (TSID)** screen, type the identification information (usually your fax number and your name or business name) in the **TSID** box. This information will appear in the header area of the faxes you send and identifies your fax machine to the person who receives your faxes.

NOTE: The TSID is mandatory in some areas.

- 10 Click **Next**.

NOTE: Steps 10-13 only occur if you enabled your machine to receive faxes in step 6.

- 11 On the **Called Subscriber Identification (CSID)** screen, type the CSID (appears to confirm that the fax is being sent to the correct recipient) that you want in the **CSID** box.
- 12 Click **Next**.
- 13 On the **Routing Options** screen, click to select the **Print it on** check box if you want each received fax to be automatically printed. When you select this check box, select the **Dell Photo AIO Printer 922** to print the received fax.
- 14 Click to select the **Store a copy in a folder** check box if you want to create an archive copy of each fax. When you select this check box, you are able to specify the storage location for the fax copy.
- 15 Click **Next**.

- 16** Confirm the configuration settings in the **Configuration Summary** list, and then click **Finish**.

You are now ready to send or receive faxes.

Changing the Fax Configuration

- 1** Click **Start** → **Programs** or **All Programs** → **Accessories** → **Communications** → **Fax**, and then click **Fax Console**.
- 2** In Fax Console, click **Configure Fax** on the **Tools** menu to start the Fax Configuration Wizard.

SECTION 3

Understanding the Software

Using the Dell All-In-One Center

Using Print Properties

Using the Dell Printer Solution Center

Using Dell Picture Studio v2.0

Understanding the Printer Software

The printer software includes:

- Dell Printer Solution Center — Provides maintenance and troubleshooting help, basic usage information, and how-to's for creating projects.
- Dell All-In-One Center — Allows you to perform various scan, copy, fax, and print operations with newly scanned and previously saved documents and images.
- Print Properties — Allows you to adjust printer settings.
- Dell Picture Studio v2.0 — Allows you to manage, edit, display, print, and convert photos and other types of images.

Using the Dell Printer Solution Center

Three tabs on the Dell Printer Solution Center provide you with a variety of printing options.

Advanced tab

- **Printing Status** button - Click this button to see your options for displaying printing status information on your screen.
- **About** button - Click this button to view software version information.
- **Networking** button - Click this button to see your networking options.

Maintenance tab

- **Use Color Cartridge for all Black Printing** icon - Click this icon and follow the instructions on the screen to use your color cartridge for black printing.

Contacts tab

- Customer support website - support.dell.com.
- Order ink or supplies - directs you to Dell's cartridge ordering website, www.dell.com/supplies.
- Dell printer Service Tag number - displays your printer Service Tag number.

To access the Dell Printer Solution Center:

Click **Start**→**Programs** or **All Programs**→**Dell Printers**→**Dell Photo AIO Printer 922**→**Dell Printer Solution Center**.

Using the Dell All-In-One Center

The Dell All-In-One Center allows you to:

- Scan, copy, fax, and perform creative tasks.
- Select where you want to send the scanned image.
- Select the quantity and color of your copies.
- Access troubleshooting and maintenance information.
- Preview images you want to print or copy.
- Manage photos (copy them to folders, print them, perform creative copying).

To access the Dell All-In-One Center:

Click **Start**→**Programs** or **All Programs**→**Dell Printers**→**Dell Photo AIO Printer 922**→**Dell All-In-One Center**.

The Dell All-In-One Center includes four main sections: **Scan or Fax**, **Copy**, **Creative Tasks**, and **Preview**.

In this section:	You can:
Scan or Fax	<ul style="list-style-type: none">• Select the program where you want to send the scanned image.• Select the type of image being scanned.• Select how you will use the scan.• Select Fax Now. <p>NOTE: Click See More Scan Settings to view all settings.</p>
Copy	<ul style="list-style-type: none">• Select the quantity and color of your copies.• Select a quality setting for your copies.• Adjust the size of the scanned area.• Lighten or darken your copies (this can also be accomplished using the operator panel).• Enlarge or reduce your copies. <p>NOTE: Click See More Copy Settings to view all settings.</p>

In this section:	You can:
Creative Tasks	Select from a variety of creative ideas. <ul style="list-style-type: none"> • Enlarge or reduce an image. • Repeat an image several times on one page. • Print an image as a multi-page poster. • E-mail an image. • Fax using your computer's modem. • Save an image on your computer. • Edit text found in a scanned document (Optical Character Recognition). • Modify an image with a photo editor.
Preview	<ul style="list-style-type: none"> • Select a portion of the preview image to scan. • View an image of what will be printed or copied.

For more information on using the **Dell All-In-One Center**, see your *User's Guide* on the CD. For more information about the **Dell All-In-One Center**, click **Help** in the Dell All-In-One Center.

Using Print Properties

Print Properties allows you to change the various printer settings. You can change your printer settings in **Print Properties** depending on the type of project you want to create.

To access **Print Properties**:

- 1 With your document open, click **File**→**Print**.
The **Print** dialog box appears.
- 2 In the **Print** dialog box, click **Preferences**, **Properties**, **Options**, or **Setup** (depending on the program or operating system).
The **Print Properties** screen appears.

To access **Print Properties** when a document is not open:

- 1 In Windows XP, click **Start**→**Settings**→**Printers and Faxes**.
In Windows 2000, click **Start**→**Settings**→**Printers**.
- 2 Right-click on the printer icon, and then select **Printer Preferences**.

 **NOTE:** Changes made to the printer settings from the **Printers** folder become the default settings for most programs.

Print Properties Tabs

Print Properties includes three main tabs.

From this tab:	You can change these settings:
Quality/Copies	<p>Quality/Speed — Select Automatic, Draft, Normal, or Photo depending on your desired output quality. Draft is the fastest option but should not be selected if you have a photo cartridge installed.</p> <p>Multiple Copies — Customize how the printer prints several photocopies of a single print job: Collated, Normal, or Print Last Page First.</p> <p>Print Color Images in Black and White — Print your color images in black and white to save the ink in your color ink cartridge.</p> <p>NOTE: You cannot select this setting if you have selected Color Cartridge for all Black Printing.</p> <p>Automatic Image Sharpening — Automatically select the best image sharpening level based on image content.</p>
Paper Setup	<p>Paper Size — Select the size and type of paper.</p> <p>Orientation — Select how the document is arranged on the printed page. You can print using portrait or landscape orientation.</p>
Print Layout	<p>Layout — Select Normal, Banner, Borderless, Mirror, N-up, Poster, or Booklet.</p> <p>Duplexing — Select this to print on both sides of the paper.</p>

Using Dell Picture Studio v2.0

In Dell Picture Studio v2.0, you can explore digital photography and learn how to organize, create, or print photos. There are three components to the Dell Picture Studio:

- Paint Shop Photo Album

Click **Start**→**Programs**→**Dell Picture Studio v2.0**→**Paint Shop Photo Album 4**→**Paint Shop Photo Album**

- Dell Picture Studio Home

Click **Start**→**Programs**→**Dell Picture Studio v2.0**→**Dell Picture Studio Home**

- Dell.Shutterfly.com - Online Print Service
Click **Start**→**Programs**→**Dell Picture Studio v2.0**→**Dell.Shutterfly.com - Online Print Service**

SECTION 4

Ink Cartridge Maintenance

Replacing Ink Cartridges

Aligning Ink Cartridges

Cleaning the Ink Cartridge Nozzles

Replacing Ink Cartridges

CAUTION: Before performing any of the procedures listed in this section, read and follow the "CAUTION: SAFETY INSTRUCTIONS" on page 9.

Dell ink cartridges are available only through Dell. You can order more ink online at www.dell.com/supplies or by phone. To order by phone, see "Ordering Ink Cartridges and Supplies" on page 2.

Dell recommends Dell ink cartridges for your printer. Dell does not provide warranty coverage for problems caused by using accessories, parts, or components not supplied by Dell.

- 1 Turn on your printer.
- 2 Lift the printer unit and position the scanner support between the tabs to keep it open.

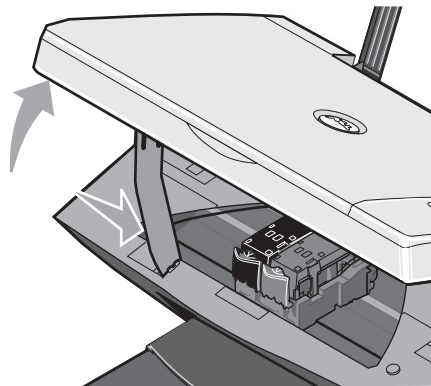

The ink cartridge carrier moves and stops at the loading position unless the printer is busy.

- 3 Press down on the ink cartridge lever to raise each ink cartridge lid.

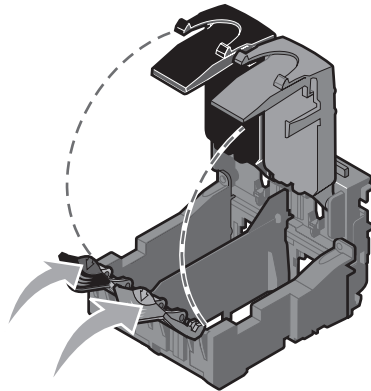

- 4 Remove the old ink cartridges.

photo or black
cartridge

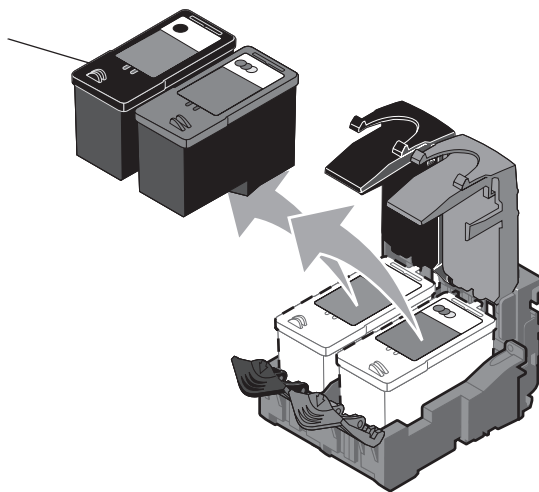

- 5 Store the cartridges in an air-tight container, such as the storage unit you received with your photo cartridge (sold separately), or dispose of them properly.

- 6 If you are installing new ink cartridges, remove the sticker and transparent tape from the back and bottom of each ink cartridge.

 **NOTE:** The illustration below shows a black cartridge and a color cartridge (use for normal printing). For photo printing, use a photo cartridge and a color cartridge.

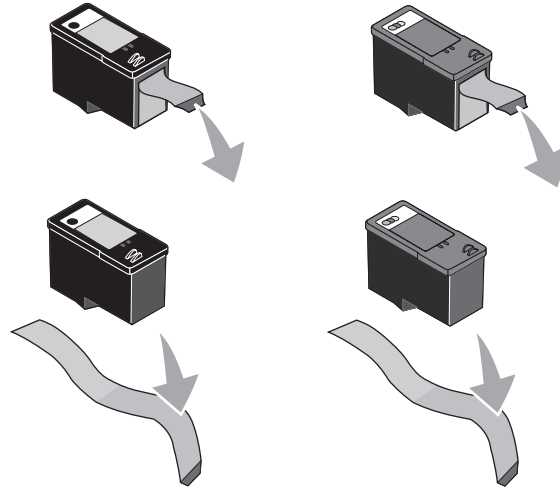

- 7 Insert the new ink cartridges. Make sure the black or photo ink cartridge is secure in the left ink cartridge carrier and the color ink cartridge is secure in the right ink cartridge carrier.

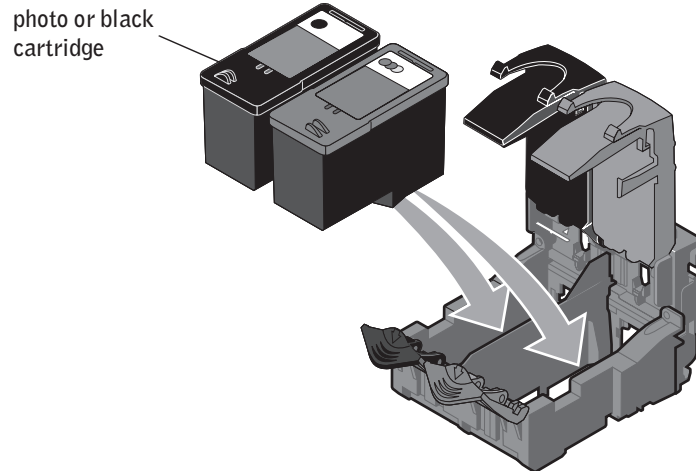

- 8 Snap each lid closed.

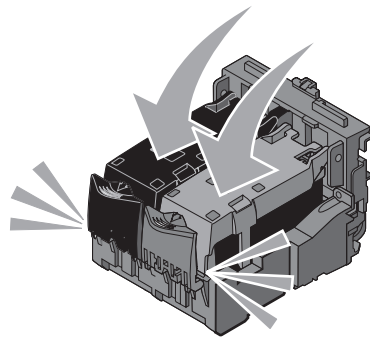

- 9 Lift the printer unit, and hold the scanner support up while lowering the printer unit until it is completely closed.

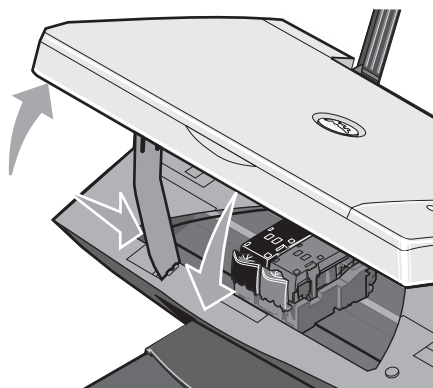

Aligning Ink Cartridges

Your printer automatically aligns the ink cartridges when they are installed or replaced. To verify your ink cartridges are aligned, you can print an alignment page. After you close the printer unit, press the Menu button. The alignment page begins printing. During printing, the operator panel display reads `Alignment Page Printing`. When complete, the message reads `Auto Alignment Complete`. Your ink cartridges are now aligned for optimal print quality.

You may also need to align ink cartridges when characters are not properly formed or are not aligned at the left margin, or when vertical or straight lines appear wavy.

To align the ink cartridges:

- 1 Load plain paper. For more information, see "Loading Paper" on page 18.

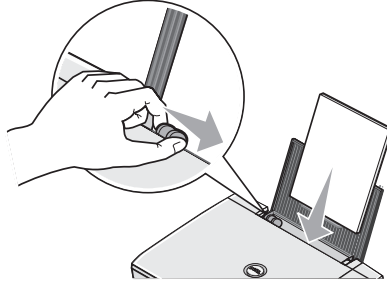

- 2 Click **Start**→**Programs** or **All Programs**→**Dell Printers**→**Dell Photo AIO Printer 922**→**Dell Printer Solution Center**.
- 3 Click the **Maintenance** tab
- 4 Click **Align to fix blurry edges**.
- 5 Click **Print**.

The ink cartridges align when the page prints.

Cleaning the Ink Cartridge Nozzles

You may need to clean the nozzles when:

- White lines appear in graphics or solid black areas.
- Print appears smudged or too dark.
- Colors fade, do not print, or do not print completely.
- Vertical lines appear jagged or edges appear rough.

To clean the ink cartridge nozzles:

- 1 Load the paper. For more information, see "Loading Paper" on page 18.

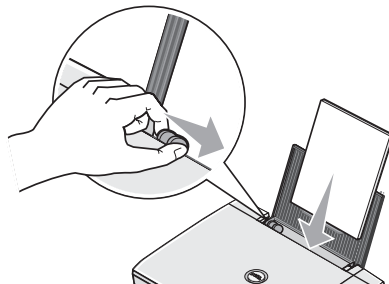

- 2 Click **Start**→**Programs** or **All Programs**→**Dell Printers**→**Dell Photo AIO Printer 922**→**Dell Printer Solution Center**.
- 3 Click the **Maintenance** tab.
- 4 Click **Clean to fix horizontal streaks**.
- 5 Click **Print**.

When the page prints it forces ink through the clogged nozzles to clean them.

- 6 Print your document again to verify the improved print quality.
- 7 If you are not satisfied with the print quality, wipe the ink cartridge nozzles, and then print your document again.

5

SECTION 5

Troubleshooting

Setup Problems

General Problems

Error Messages and Lights

Improving Print Quality

Troubleshooting

Follow these tips when you troubleshoot your printer:

- If the printer does not work, ensure that the printer is properly connected to the electrical outlet and computer, if using a computer.
- If an error message appears on the operator panel display, write down the exact message.

Setup Problems

Computer Problems

VERIFY THAT YOUR PRINTER IS COMPATIBLE WITH YOUR COMPUTER — The Dell Photo AIO Printer 922 supports Windows 2000 and Windows XP.

MAKE SURE YOU TURNED ON BOTH YOUR PRINTER AND YOUR COMPUTER

CHECK THE USB CABLE —

- Ensure that the USB cable is firmly connected to your printer and your computer.
- Shut down the computer, reconnect the USB cable as shown on the setup diagram for your printer, and then restart the computer.

IF THE SOFTWARE INSTALLATION SCREEN DOES NOT APPEAR AUTOMATICALLY, INSTALL THE SOFTWARE MANUALLY —

- 1 Insert the Drivers and Utilities CD.
- 2 Click **Install**.

DETERMINE IF THE PRINTER SOFTWARE IS INSTALLED — Click **Start**→**Programs** or **All Programs**→**Dell Printers**→**Dell Photo AIO Printer 922**. If the **Dell Photo AIO Printer 922** does not appear in the list of programs, the printer software is not installed. Install the printer software. For more information, see "Removing and Reinstalling Software" on page 53

CORRECT COMMUNICATION PROBLEMS BETWEEN THE PRINTER AND THE COMPUTER —

- Remove the USB cable from your printer and your computer. Reconnect the USB cable to your printer and your computer.
- Turn off the printer. Unplug the printer power cable from the electrical outlet. Reconnect the printer power cable into the electrical outlet and turn on the printer.
- Restart your computer.

SET YOUR PRINTER AS THE DEFAULT PRINTER —

Windows XP

- 1** Click **Start**→**Printers and Faxes**.
- 2** Right-click **Dell Photo AIO Printer 922** and select **Set as Default**.

Windows 2000

- 1** Click **Start**→**Settings**→**Printers**.
- 2** Right-click **Dell Photo AIO Printer 922** and select **Set as Default**.

Removing and Reinstalling Software

If your printer does not function properly or communication error messages appear when using your printer, you can remove and reinstall the printer software.

- 1** Click **Start**→**Programs** or **All Programs**→**Dell Printers**→**Dell Photo AIO Printer 922**→**Uninstall Dell AIO Printer 922**.
- 2** Follow the instructions on the screen.
- 3** Restart your computer.
- 4** Insert the **Drivers and Utilities CD**, and then follow the instructions on the screen.

If the installation screen does not appear:

- a** In *Windows XP*, click **Start**→**My Computer**.
In *Windows 2000*, double-click **My Computer** from your desktop.
- b** Double-click the **CD-ROM drive** icon. If necessary, double-click **setup.exe**.
- c** When the printer software installation screen appears, click **Install** or **Install Now**.
- d** Follow the instructions on your screen to complete the installation.

Printer Problems

ENSURE THAT THE PRINTER POWER CABLE IS FIRMLY CONNECTED TO THE PRINTER AND THE ELECTRICAL OUTLET —

DETERMINE IF THE PRINTER HAS BEEN HELD OR PAUSED —

Windows XP

- 1 Click **Start**→**Settings**→**Printers and Faxes**.
- 2 Double-click **Dell Photo AIO Printer 922**, and then click **Printer**.
- 3 Make sure a check mark is not next to **Pause Printing**. If a check mark is next to **Pause Printing**, click it to deselect the option.

Windows 2000

- 1 Click **Start**→**Settings**→**Printers**.
- 2 Double-click **Dell Photo AIO Printer 922**, and then click **Printer**.
- 3 Make sure a check mark is not next to **Pause Printing**. If a check mark is next to **Pause Printing**, click **Pause Printing** to deselect it.

CHECK FOR FLASHING LIGHTS ON THE PRINTER — For more information, see "Error Messages and Lights" on page 57

ENSURE YOU INSTALLED THE INK CARTRIDGES CORRECTLY AND REMOVED THE STICKER AND TAPE FROM EACH CARTRIDGE —

MAKE SURE YOU LOADED THE PAPER CORRECTLY — For more information, see "Loading Paper" on page 18.

General Problems

Fax Problems

MAKE SURE YOU TURNED ON BOTH YOUR PRINTER AND YOUR COMPUTER AND THE USB CABLE IS PROPERLY CONNECTED

ENSURE THE COMPUTER IS CONNECTED TO AN ACTIVE ANALOG PHONE LINE —

Using the fax function requires a phone connection to the fax/modem in your computer.

When using DSL: to fax, make sure you have a DSL filter installed.

Make sure your computer is not connected to the Internet when trying to fax.

WHEN USING AN EXTERNAL MODEM, MAKE SURE IT IS TURNED ON AND IT IS CORRECTLY CONNECTED TO YOUR COMPUTER

Paper Problems

MAKE SURE YOU LOADED THE PAPER CORRECTLY — FOR MORE INFORMATION, SEE "LOADING PAPER" ON PAGE 18.

USE ONLY PAPER RECOMMENDED FOR YOUR PRINTER — FOR MORE INFORMATION, SEE "PRINT MEDIA GUIDELINES FOR THE PAPER SUPPORT" ON PAGE 19.

USE A SMALLER AMOUNT OF PAPER WHEN PRINTING MULTIPLE PAGES — FOR MORE INFORMATION, SEE "PRINT MEDIA GUIDELINES FOR THE PAPER SUPPORT" ON PAGE 19.

MAKE SURE THE PAPER IS NOT WRINKLED, TORN OR DAMAGED

MAKE SURE THE PAPER IS AGAINST THE RIGHT SIDE OF THE PAPER SUPPORT AND THE PAPER GUIDE RESTS AGAINST THE LEFT EDGE OF THE PAPER.

CHECK FOR A PAPER JAM

Using your printer and your computer

- Follow the instructions on the screen for clearing the paper jam.

Using your printer only

If the paper jam is located in the paper support:

- 1 Turn off your printer.
- 2 Firmly grasp the paper and gently pull it from the printer.
- 3 Turn on your printer and print the document again.

If the paper jam is not visible:

- 1 Turn off your printer.
- 2 Lift the printer unit and position the scanner support between the tabs to keep it open.

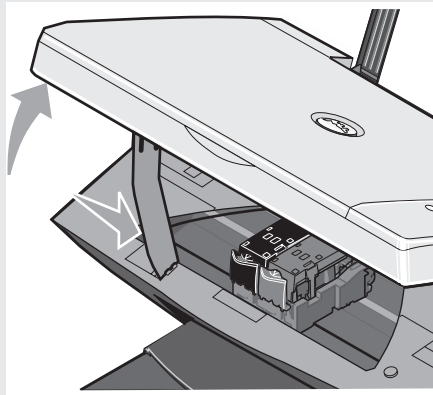

- 3 Gently pull the paper from the printer.
- 4 Close the printer unit, turn on the printer, and print the document again.

Error Messages and Lights

The following error messages can be found on your computer screen or operator panel display.

Error Message:	What it indicates:	Solution:
Blinking Power button	The printer has a paper jam or is out of paper.	If the printer is out of paper, see "Loading Paper" on page 18. If a paper jam exists, see "Paper Problems" on page 55.
Ink Low Alert	The ink cartridge is running low on ink. The Low Ink Alert occurs when your ink cartridges reach levels of 25 percent, 15 percent, and 5 percent remaining.	Replace the ink cartridge. For more information, see "Replacing Ink Cartridges" on page 44.
Reserve tank	An ink cartridge's available ink dot count is zero.	Order a new ink cartridge from Dell and replace the old ink cartridge. To order a new ink cartridge, go to www.dell.com/supplies .
Paper jam	A paper jam exists in the printer.	Clear the paper jam. For more information, see "Check for a paper jam" on page 56.

Error Message:	What it indicates:	Solution:
Paper tray empty	The printer is out of paper.	Load more paper into the printer. For more information, see "Loading Paper" on page 18.
Printhead error	The ink cartridge has a short.	Disconnect and then reconnect the printer power cable. Reinstall the ink cartridges. For more information, see "Replacing Ink Cartridges" on page 44.
Print carrier error	Print carrier error.	Disconnect the printer power cable, check for paper jams, and then reconnect the power cable.
Data error	Data error or incomplete data.	Press the Power button to reset.
Scan carrier error	Scan carrier error.	Turn off the printer, wait a few seconds, and then turn on the printer.
Paper feed error	A paper feed error has occurred.	Press the Power button to reset.
System control error	A paper system control error has occurred.	Press the Power button to reset.

Improving Print Quality

If you are not satisfied with the print quality of your documents, there are several different ways to improve the print quality.

- Use the appropriate paper. For example, use Dell Premium Photo Paper if you are printing photos with a photo ink cartridge.
- Use paper that is a heavier weight, bright white, or coated. Use Dell Premium Photo Paper if you are printing photos.
- Select a higher print quality. To select a higher print quality:

1 With your document open, click **File**→**Print**.

The **Print** dialog box appears.

- 2** Click **Preferences**, **Properties**, or **Options** (depending on your program or operating system).
- 3** On the **Quality/Copies** tab, select **Quality/Speed** and select a higher quality setting.
- 4** Print your document again.
- 5** If the print quality does not improve, try aligning or cleaning the ink cartridges. For more information on aligning, see "Aligning Ink Cartridges" on page 47. For more information on cleaning ink cartridges, see "Cleaning the Ink Cartridge Nozzles" on page 48.

For additional solutions, check your Dell Printer Solution Center or go to support.dell.com.

To access the Dell Printer Solution Center:

- 1** Click **Start**→**Programs** or **All Programs**→**Dell Printers**→**Dell Photo AIO Printer 922**→**Dell Printer Solution Center**.
- 2** Click the **Troubleshooting** tab.

6

SECTION 6

Contacting Dell

Technical Assistance

Automated Order-Status Service

Contacting Dell

Technical Assistance

If you need help with a technical problem, Dell is ready to assist you.

- 1 Call technical support from a telephone near or at the printer so that technical support can assist you with any necessary procedures. When calling Dell, use your Express Service Code to help expedite the routing of your call to the proper support personnel.

The Express Service Code is located on the back panel of the printer near the serial number for the printer.

NOTE: Dell's Express Service Code system may not be available in all countries.

- 2 In the U.S., Business customers should call 1-877-459-7298, and Consumer (Home and Home Office) customers should call 1-800-624-9896.

If you are calling from a different country or are in a different Service area, see "Contacting Dell" on page 63 for your local telephone number.

- 3 Follow the menu prompts in the automated telephone system to speak with a technical support representative.

Automated Order-Status Service

To check on the status of any Dell products that you have ordered, you can go to support.dell.com, or you can call the automated order-status service. A recording prompts you for the information needed to locate and report on your order. See "Contacting Dell" on page 63 for the telephone number to call for your region.

Contacting Dell

To contact Dell electronically, you can access the following websites:

- www.dell.com
- support.dell.com (technical support)
- premiersupport.dell.com (technical support for educational, government, health care, and medium/large business customers, including Premier, Platinum, and Gold customers)

For specific web addresses for your country, find the appropriate country section in the table below.

NOTE: Toll-free numbers are for use within the country for which they are listed.

When you need to contact Dell, use the electronic addresses, telephone numbers, and codes provided in the following table. If you need assistance in determining which codes to use, contact a local or an international operator.

Country (City) International Access Code Country Code City Code	Department Name or Service Area, Website and E-Mail Address	Area Codes, Local Numbers, and Toll-Free Numbers
U.S.A. (Austin, Texas)	Automated Order-Status Service	toll-free: 1-800-433-9014
International Access Code: 011 Country Code: 1	AutoTech (portable and desktop computers)	toll-free: 1-800-247-9362
	Consumer (Home and Home Office)	
	Technical Support	toll-free: 1-800-624-9896
	Customer Service	toll-free: 1-800-624-9897
	DellNet™ Service and Support	toll-free: 1-877-Dellnet (1-877-335-5638)
	Employee Purchase Program (EPP) Customers	toll-free: 1-800-695-8133
	Financial Services website: www.dellfinancialservices.com	
	Financial Services (lease/loans)	toll-free: 1-877-577-3355
	Financial Services (Dell Preferred Accounts [DPA])	toll-free: 1-800-283-2210
	Business	
	Customer Service and Technical Support	toll-free: 1-877-459-7298
	Employee Purchase Program (EPP) Customers	toll-free: 1-800-695-8133
	Printers and Projectors Technical Support	toll-free: 1-877-459-7298
	Public (government, education, and healthcare)	
	Customer Service and Technical Support	toll-free: 1-800-456-3355
	Employee Purchase Program (EPP) Customers	toll-free: 1-800-234-1490
	Dell Sales	toll-free: 1-800-289-3355 or toll-free: 1-800-879-3355
	Dell Outlet Store (Dell refurbished computers)	toll-free: 1-888-798-7561
	Software and Peripherals Sales	toll-free: 1-800-671-3355
	Spare Parts Sales	toll-free: 1-800-357-3355
	Extended Service and Warranty Sales	toll-free: 1-800-247-4618
	Fax	toll-free: 1-800-727-8320
	Dell Services for the Deaf, Hard-of-Hearing, or Speech-Impaired	toll-free: 1-877-DELLTTY (1-877-335-5889)
Anguilla	General Support	toll-free: 800-335-0031
Antigua and Barbuda	General Support	1-800-805-5924

Country (City) International Access Code Country Code City Code	Department Name or Service Area, Website and E-Mail Address	Area Codes, Local Numbers, and Toll-Free Numbers
Argentina (Buenos Aires)	Website: www.dell.com.ar	
International Access Code: 00	Tech Support and Customer Care	toll-free: 0-800-444-0733
Country Code: 54	Sales	0-810-444-3355
City Code: 11	Tech Support Fax	11 4515 7139
	Customer Care Fax	11 4515 7138
Aruba	General Support	toll-free: 800-1578
Australia (Sydney)	E-mail (Australia): au_tech_support@dell.com	
International Access Code: 0011	E-mail (New Zealand): nz_tech_support@dell.com	
Country Code: 61	Home and Small Business	1-300-65-55-33
City Code: 2	Government and Business	toll-free: 1-800-633-559
	Preferred Accounts Division (PAD)	toll-free: 1-800-060-889
	Customer Care	toll-free: 1-800-819-339
	Corporate Sales	toll-free: 1-800-808-385
	Transaction Sales	toll-free: 1-800-808-312
	Fax	toll-free: 1-800-818-341
Austria (Vienna)	Website: support.euro.dell.com	
International Access Code: 900	E-mail: tech_support_central_europe@dell.com	
Country Code: 43	Home/Small Business Sales	0820 240 530 00
City Code: 1	Home/Small Business Fax	0820 240 530 49
	Home/Small Business Customer Care	0820 240 530 14
	Preferred Accounts/Corporate Customer Care	0820 240 530 16
	Home/Small Business Technical Support	0820 240 530 14
	Preferred Accounts/Corporate Technical Support	0660 8779
	Switchboard	0820 240 530 00
Bahamas	General Support	toll-free: 1-866-278-6818
Barbados	General Support	1-800-534-3066

Country (City) International Access Code Country Code City Code	Department Name or Service Area, Website and E-Mail Address	Area Codes, Local Numbers, and Toll-Free Numbers
Belgium (Brussels)	Website: support.euro.dell.com	
International Access Code: 00	E-mail: tech_be@dell.com	
Country Code: 32	E-mail for French Speaking Customers: support.euro.dell.com/be/fr/emaildell/	
City Code: 2	Technical Support	02 481 92 88
	Customer Care	02 481 91 19
	Corporate Sales	02 481 91 00
	Fax	02 481 92 99
	Switchboard	02 481 91 00
Bermuda	General Support	1-800-342-0671
Bolivia	General Support	toll-free: 800-10-0238
Brazil	Website: www.dell.com/br	
International Access Code: 00	Customer Support, Technical Support	0800 90 3355
Country Code: 55	Tech Support Fax	51 481 5470
City Code: 51	Customer Care Fax	51 481 5480
	Sales	0800 90 3390
British Virgin Islands	General Support	toll-free: 1-866-278-6820
Brunei	Customer Technical Support (Penang, Malaysia)	604 633 4966
Country Code: 673	Customer Service (Penang, Malaysia)	604 633 4949
	Transaction Sales (Penang, Malaysia)	604 633 4955
Canada (North York, Ontario)	Online Order Status: www.dell.ca/ostatus	
International Access Code: 011	AutoTech (automated technical support)	toll-free: 1-800-247-9362
	TechFax	toll-free: 1-800-950-1329
	Customer Care (Home Sales/Small Business)	toll-free: 1-800-847-4096
	Customer Care (med./large business, government)	toll-free: 1-800-326-9463
	Technical Support (Home Sales/Small Business)	toll-free: 1-800-847-4096
	Technical Support (med./large bus., government)	toll-free: 1-800-387-5757
	Sales (Home Sales/Small Business)	toll-free: 1-800-387-5752
	Sales (med./large bus., government)	toll-free: 1-800-387-5755
	Spare Parts Sales & Extended Service Sales	1 866 440 3355

Country (City) International Access Code Country Code City Code	Department Name or Service Area, Website and E-Mail Address	Area Codes, Local Numbers, and Toll-Free Numbers
Cayman Islands	General Support	1-800-805-7541
Chile (Santiago) Country Code: 56 City Code: 2	Sales, Customer Support, and Technical Support	toll-free: 1230-020-4823
China (Xiamen) Country Code: 86 City Code: 592	Tech Support website: support.ap.dell.com/china Tech Support E-mail: cn_support@dell.com Tech Support Fax	818 1350
	Home and Small Business Technical Support	toll-free: 800 858 2437
	Corporate Accounts Technical Support	toll-free: 800 858 2333
	Customer Experience	toll-free: 800 858 2060
	Home and Small Business	toll-free: 800 858 2222
	Preferred Accounts Division	toll-free: 800 858 2557
	Large Corporate Accounts GCP	toll-free: 800 858 2055
	Large Corporate Accounts Key Accounts	toll-free: 800 858 2628
	Large Corporate Accounts North	toll-free: 800 858 2999
	Large Corporate Accounts North Government and Education	toll-free: 800 858 2955
	Large Corporate Accounts East	toll-free: 800 858 2020
	Large Corporate Accounts East Government and Education	toll-free: 800 858 2669
	Large Corporate Accounts Queue Team	toll-free: 800 858 2222
	Large Corporate Accounts South	toll-free: 800 858 2355
	Large Corporate Accounts West	toll-free: 800 858 2811
	Large Corporate Accounts Spare Parts	toll-free: 800 858 2621
Colombia	General Support	980-9-15-3978
Costa Rica	General Support	0800-012-0435

Country (City) International Access Code Country Code City Code	Department Name or Service Area, Website and E-Mail Address	Area Codes, Local Numbers, and Toll-Free Numbers
Czech Republic (Prague)	Website: support.euro.dell.com	
International Access Code: 00	E-mail: czech_dell@dell.com	
Country Code: 420	Technical Support	02 2186 27 27
City Code: 2	Customer Care	02 2186 27 11
	Fax	02 2186 27 14
	TechFax	02 2186 27 28
	Switchboard	02 2186 27 11
Denmark (Copenhagen)	Website: support.euro.dell.com	
International Access Code: 00	E-mail Support (portable computers): den_nbk_support@dell.com	
Country Code: 45	E-mail Support (desktop computers): den_support@dell.com	
	E-mail Support (servers): Nordic_server_support@dell.com	
	Technical Support	7023 0182
	Customer Care (Relational)	7023 0184
	Home/Small Business Customer Care	3287 5505
	Switchboard (Relational)	3287 1200
	Fax Switchboard (Relational)	3287 1201
	Switchboard (Home/Small Business)	3287 5000
	Fax Switchboard (Home/Small Business)	3287 5001
Dominica	General Support	toll-free: 1-866-278-6821
Dominican Republic	General Support	1-800-148-0530
Ecuador	General Support	toll-free: 999-119
El Salvador	General Support	01-899-753-0777

Country (City) International Access Code Country Code City Code	Department Name or Service Area, Website and E-Mail Address	Area Codes, Local Numbers, and Toll-Free Numbers
Finland (Helsinki)	Website: support.euro.dell.com	
International Access Code: 990	E-mail: fin_support@dell.com	
Country Code: 358	E-mail Support (servers): Nordic_support@dell.com	
City Code: 9	Technical Support	09 253 313 60
	Technical Support Fax	09 253 313 81
	Relational Customer Care	09 253 313 38
	Home/Small Business Customer Care	09 693 791 94
	Fax	09 253 313 99
	Switchboard	09 253 313 00
France (Paris) (Montpellier)	Website: support.euro.dell.com	
International Access Code: 00	E-mail: support.euro.dell.com/fr/fr/emaildell/	
Country Code: 33	Home and Small Business	
City Codes: (1) (4)	Technical Support	0825 387 270
	Customer Care	0825 823 833
	Switchboard	0825 004 700
	Switchboard (calls from outside of France)	04 99 75 40 00
	Sales	0825 004 700
	Fax	0825 004 701
	Fax (calls from outside of France)	04 99 75 40 01
	Corporate	
	Technical Support	0825 004 719
	Customer Care	0825 338 339
	Switchboard	01 55 94 71 00
	Sales	01 55 94 71 00
	Fax	01 55 94 71 01

Country (City) International Access Code Country Code City Code	Department Name or Service Area, Website and E-Mail Address	Area Codes, Local Numbers, and Toll-Free Numbers
Germany (Langen)	Website: support.euro.dell.com	
International Access Code: 00	E-mail: tech_support_central_europe@dell.com	
Country Code: 49	Technical Support	06103 766-7200
City Code: 6103	Home/Small Business Customer Care	0180-5-224400
	Global Segment Customer Care	06103 766-9570
	Preferred Accounts Customer Care	06103 766-9420
	Large Accounts Customer Care	06103 766-9560
	Public Accounts Customer Care	06103 766-9555
	Switchboard	06103 766-7000
Greece	Website: support.euro.dell.com	
International Access Code: 00	E-mail: support.euro.dell.com/gr/en/emaildell/	
Country Code: 30	Technical Support	080044149518
	Gold Technical Support	08844140083
	Switchboard	2108129800
	Sales	2108129800
	Fax	2108129812
Grenada	General Support	toll-free: 1-866-540-3355
Guatemala	General Support	1-800-999-0136
Guyana	General Support	toll-free: 1-877-270-4609

Country (City) International Access Code Country Code City Code	Department Name or Service Area, Website and E-Mail Address	Area Codes, Local Numbers, and Toll-Free Numbers
Hong Kong	Website: support.ap.dell.com	
International Access Code: 001	E-mail: ap_support@dell.com	
Country Code: 852	Technical Support (Dimension™ and Inspiron™)	2969 3189
	Technical Support (OptiPlex™, Latitude™, and Dell Precision™)	2969 3191
	Technical Support (PowerApp™ and PowerVault™)	2969 3196
	Gold Queue EEC Hotline	2969 3187
	Customer Advocacy	3416 0910
	Large Corporate Accounts	3416 0907
	Global Customer Programs	3416 0908
	Medium Business Division	3416 0912
	Home and Small Business Division	2969 3105
India	Technical Support	1600 33 8045
	Sales	1600 33 8044
Ireland (Cherrywood)	Website: support.euro.dell.com	
International Access Code: 16	E-mail: dell_direct_support@dell.com	
Country Code: 353	Technical Support	1850 543 543
City Code: 1	U.K. Technical Support (dial within U.K. only)	0870 908 0800
	Home User Customer Care	01 204 4014
	Small Business Customer Care	01 204 4014
	U.K. Customer Care (dial within U.K. only)	0870 906 0010
	Corporate Customer Care	1850 200 982
	Corporate Customer Care (dial within U.K. only)	0870 907 4499
	Ireland Sales	01 204 4444
	U.K. Sales (dial within U.K. only)	0870 907 4000
	Fax/SalesFax	01 204 0103
	Switchboard	01 204 4444

Country (City) International Access Code Country Code City Code	Department Name or Service Area, Website and E-Mail Address	Area Codes, Local Numbers, and Toll-Free Numbers
Italy (Milan)	Website: support.euro.dell.com	
International Access Code: 00	E-mail: support.euro.dell.com/it/it/emaildell/	
Country Code: 39	Home and Small Business	
City Code: 02	Technical Support	02 577 826 90
	Customer Care	02 696 821 14
	Fax	02 696 821 13
	Switchboard	02 696 821 12
	Corporate	
	Technical Support	02 577 826 90
	Customer Care	02 577 825 55
	Fax	02 575 035 30
	Switchboard	02 577 821
Jamaica	General Support (dial from within Jamaica only)	1-800-682-3639

Country (City) International Access Code Country Code City Code	Department Name or Service Area, Website and E-Mail Address	Area Codes, Local Numbers, and Toll-Free Numbers
Japan (Kawasaki)	Website: support.jp.dell.com	
International Access Code: 001	Technical Support (servers)	toll-free: 0120-198-498
Country Code: 81	Technical Support outside of Japan (servers)	81-44-556-4162
City Code: 44	Technical Support (Dimension™ and Inspiron™)	toll-free: 0120-198-226
	Technical Support outside of Japan (Dimension and Inspiron)	81-44-520-1435
	Technical Support (Dell Precision™, OptiPlex™, and Latitude™)	toll-free:0120-198-433
	Technical Support outside of Japan (Dell Precision, OptiPlex, and Latitude)	81-44-556-3894
	Technical Support	toll-free: 0120-981-690
	Technical Support outside of Japan (Axim)	81-44-556-3468
	Faxbox Service	044-556-3490
	24-Hour Automated Order Service	044-556-3801
	Customer Care	044-556-4240
	Business Sales Division (up to 400 employees)	044-556-1465
	Preferred Accounts Division Sales (over 400 employees)	044-556-3433
	Large Corporate Accounts Sales (over 3500 employees)	044-556-3430
	Public Sales (government agencies, educational institutions, and medical institutions)	044-556-1469
	Global Segment Japan	044-556-3469
	Individual User	044-556-1760
	Switchboard	044-556-4300
Korea (Seoul)	Technical Support	toll-free: 080-200-3800
International Access Code: 001	Sales	toll-free: 080-200-3600
Country Code: 82	Customer Service (Seoul, Korea)	toll-free: 080-200-3800
City Code: 2	Customer Service (Penang, Malaysia)	604 633 4949
	Fax	2194-6202
	Switchboard	2194-6000

Country (City) International Access Code Country Code City Code	Department Name or Service Area, Website and E-Mail Address	Area Codes, Local Numbers, and Toll-Free Numbers
Latin America	Customer Technical Support (Austin, Texas, U.S.A.)	512 728-4093
	Customer Service (Austin, Texas, U.S.A.)	512 728-3619
	Fax (Technical Support and Customer Service) (Austin, Texas, U.S.A.)	512 728-3883
	Sales (Austin, Texas, U.S.A.)	512 728-4397
	SalesFax (Austin, Texas, U.S.A.)	512 728-4600 or 512 728-3772
Luxembourg	Website: support.euro.dell.com	
International Access Code: 00	E-mail: tech_be@dell.com	
Country Code: 352	Technical Support (Brussels, Belgium)	3420808075
	Home/Small Business Sales (Brussels, Belgium)	toll-free: 080016884
	Corporate Sales (Brussels, Belgium)	02 481 91 00
	Customer Care (Brussels, Belgium)	02 481 91 19
	Fax (Brussels, Belgium)	02 481 92 99
	Switchboard (Brussels, Belgium)	02 481 91 00
Macao	Technical Support	toll-free: 0800 582
Country Code: 853	Customer Service (Penang, Malaysia)	604 633 4949
	Transaction Sales	toll-free: 0800 581
Malaysia (Penang)	Technical Support	toll-free: 1 800 888 298
International Access Code: 00	Customer Service	04 633 4949
Country Code: 60	Transaction Sales	toll-free: 1 800 888 202
City Code: 4	Corporate Sales	toll-free: 1 800 888 213

Country (City) International Access Code Country Code City Code	Department Name or Service Area, Website and E-Mail Address	Area Codes, Local Numbers, and Toll-Free Numbers
Mexico International Access Code: 00 Country Code: 52	Customer Technical Support Sales Customer Service Main	001-877-384-8979 or 001-877-269-3383 50-81-8800 or 01-800-888-3355 001-877-384-8979 or 001-877-269-3383 50-81-8800 or 01-800-888-3355
Montserrat	General Support	toll-free: 1-866-278-6822
Netherlands Antilles	General Support	001-800-882-1519
Netherlands (Amsterdam) International Access Code: 00 Country Code: 31 City Code: 20	Website: support.euro.dell.com E-mail (Technical Support): (Enterprise): nl_server_support@dell.com (Latitude): nl_latitude_support@dell.com (Inspiron): nl_inspiron_support@dell.com (Dimension): nl_dimension_support@dell.com (OptiPlex): nl_optiplex_support@dell.com (Dell Precision): nl_workstation_support@dell.com	
	Technical Support	020 674 45 00
	Technical Support Fax	020 674 47 66
	Home/Small Business Customer Care	020 674 42 00
	Relational Customer Care	020 674 4325
	Home/Small Business Sales	020 674 55 00
	Relational Sales	020 674 50 00
	Home/Small Business Sales Fax	020 674 47 75
	Relational Sales Fax	020 674 47 50
	Switchboard	020 674 50 00
	Switchboard Fax	020 674 47 50

Country (City) International Access Code Country Code City Code	Department Name or Service Area, Website and E-Mail Address	Area Codes, Local Numbers, and Toll-Free Numbers
New Zealand	E-mail (New Zealand): nz_tech_support@dell.com	
International Access Code: 00	E-mail (Australia): au_tech_support@dell.com	
Country Code: 64	Home and Small Business	0800 446 255
	Government and Business	0800 444 617
	Sales	0800 441 567
	Fax	0800 441 566
Nicaragua	General Support	001-800-220-1006
Norway (Lysaker)	Website: support.euro.dell.com	
International Access Code: 00	E-mail Support (portable computers):	
Country Code: 47	nor_nbk_support@dell.com	
	E-mail Support (desktop computers):	
	nor_support@dell.com	
	E-mail Support (servers):	
	nordic_server_support@dell.com	
	Technical Support	671 16882
	Relational Customer Care	671 17514
	Home/Small Business Customer Care	23162298
	Switchboard	671 16800
	Fax Switchboard	671 16865
Panama	General Support	001-800-507-0962
Peru	General Support	0800-50-669
Poland (Warsaw)	Website: support.euro.dell.com	
International Access Code: 011	E-mail: pl_support_tech@dell.com	
Country Code: 48	Customer Service Phone	57 95 700
City Code: 22	Customer Care	57 95 999
	Sales	57 95 999
	Customer Service Fax	57 95 806
	Reception Desk Fax	57 95 998
	Switchboard	57 95 999

Country (City) International Access Code Country Code City Code	Department Name or Service Area, Website and E-Mail Address	Area Codes, Local Numbers, and Toll-Free Numbers
Portugal	Website: support.euro.dell.com	
International Access Code: 00	E-mail: support.euro.dell.com/pt/en/emaildell/	
Country Code: 351	Technical Support	707200149
	Customer Care	800 300 413
	Sales	800 300 410 or 800 300 411 or 800 300 412 or 21 422 07 10
	Fax	21 424 01 12
Puerto Rico	General Support	1-800-805-7545
St. Kitts and Nevis	General Support	toll-free: 1-877-441-4731
St. Lucia	General Support	1-800-882-1521
St. Vincent and the Grenadines	General Support	toll-free: 1-877-270-4609
Singapore (Singapore)	Technical Support	toll-free: 800 6011 051
International Access Code: 005	Customer Service (Penang, Malaysia)	604 633 4949
Country Code: 65	Transaction Sales	toll-free: 800 6011 054
	Corporate Sales	toll-free: 800 6011 053
South Africa (Johannesburg)	Website: support.euro.dell.com	
International Access Code:	E-mail: dell_za_support@dell.com	
09/091	Technical Support	011 709 7710
Country Code: 27	Customer Care	011 709 7707
City Code: 11	Sales	011 709 7700
	Fax	011 706 0495
	Switchboard	011 709 7700
Southeast Asian and Pacific Countries	Customer Technical Support, Customer Service, and Sales (Penang, Malaysia)	604 633 4810

Country (City) International Access Code Country Code City Code	Department Name or Service Area, Website and E-Mail Address	Area Codes, Local Numbers, and Toll-Free Numbers
Spain (Madrid)	Website: support.euro.dell.com	
International Access Code: 00	E-mail: support.euro.dell.com/es/es/emaildell/	
Country Code: 34	Home and Small Business	
City Code: 91	Technical Support	902 100 130
	Customer Care	902 118 540
	Sales	902 118 541
	Switchboard	902 118 541
	Fax	902 118 539
	Corporate	
	Technical Support	902 100 130
	Customer Care	902 118 546
	Switchboard	91 722 92 00
	Fax	91 722 95 83
Sweden (Upplands Vasby)	Website: support.euro.dell.com	
International Access Code: 00	E-mail: swe_support@dell.com	
Country Code: 46	E-mail Support for Latitude and Inspiron: Swe-nbk_kats@dell.com	
City Code: 8	E-mail Support for OptiPlex: Swe_kats@dell.com	
	E-mail Support for Servers: Nordic_server_support@dell.com	
	Technical Support	08 590 05 199
	Relational Customer Care	08 590 05 642
	Home/Small Business Customer Care	08 587 70 527
	Employee Purchase Program (EPP) Support	20 140 14 44
	Fax Technical Support	08 590 05 594
	Sales	08 590 05 185

Country (City) International Access Code Country Code City Code	Department Name or Service Area, Website and E-Mail Address	Area Codes, Local Numbers, and Toll-Free Numbers
Switzerland (Geneva)	Website: support.euro.dell.com	
International Access Code: 00	E-mail: swisstech@dell.com	
Country Code: 41	E-mail for French-speaking HSB and Corporate Customers: support.euro.dell.com/ch/fr/emaildell/	
City Code: 22	Technical Support (Home and Small Business)	0844 811 411
	Technical Support (Corporate)	0844 822 844
	Customer Care (Home and Small Business)	0848 802 202
	Customer Care (Corporate)	0848 821 721
	Fax	022 799 01 90
	Switchboard	022 799 01 01
Taiwan	Technical Support (portable and desktop computers)	toll-free: 00801 86 1011
International Access Code: 002	Technical Support (servers)	toll-free: 0080 60 1256
Country Code: 886	Transaction Sales	toll-free: 0080 651 228
	Corporate Sales	toll-free: 0080 651 227
Thailand	Technical Support	toll-free: 0880 060 07
International Access Code: 001	Customer Service (Penang, Malaysia)	604 633 4949
Country Code: 66	Sales	toll-free: 0880 060 09
Trinidad/Tobago	General Support	1-800-805-8035
Turks and Caicos Islands	General Support	toll-free: 1-866-540-3355

Country (City) International Access Code Country Code City Code	Department Name or Service Area, Website and E-Mail Address	Area Codes, Local Numbers, and Toll-Free Numbers
U.K. (Bracknell)	Website: support.euro.dell.com	
International Access Code: 00	Customer Care website: support.euro.dell.com/uk/en/ECare/Form/Home.asp	
Country Code: 44		
City Code: 1344	E-mail: dell_direct_support@dell.com	
	Technical Support (Corporate/Preferred Accounts/PAD [1000+ employees])	0870 908 0500
	Technical Support (direct/PAD and general)	0870 908 0800
	Global Accounts Customer Care	01344 373 186
	Home and Small Business Customer Care	0870 906 0010
	Corporate Customer Care	01344 373 185
	Preferred Accounts (500–5000 employees) Customer Care	0870 906 0010
	Central Government Customer Care	01344 373 193
	Local Government & Education Customer Care	01344 373 199
	Health Customer Care	01344 373 194
	Home and Small Business Sales	0870 907 4000
	Corporate/Public Sector Sales	01344 860 456
	Home and Small Business Fax	0870 907 4006
Uruguay	General Support	toll-free: 000-413-598-2521
U.S. Virgin Islands	General Support	1-877-673-3355
Venezuela	General Support	8001-3605

SECTION 7

Appendix

Limited Warranties and Return Policy

Dell Inc. Ink and Toner Cartridges Limited Warranties

Dell Software License Agreement

Regulatory Notices

Limited Warranties and Return Policy

Dell-branded hardware products purchased in the U.S. or Canada come with either a 90-day, 1-year, 2-year, 3-year, or 4-year limited warranty. To determine which warranty came with your hardware product(s), see your packing slip or invoice. The following sections describe the limited warranties and return policy for the U.S., the limited warranties and return policy for Canada, and the manufacturer guarantee for Latin America and the Caribbean.

Limited Warranty for Dell-Branded Hardware Products (U.S. Only)

What is covered by this limited warranty?

This limited warranty covers defects in materials and workmanship in your—our end-user customer's—Dell-branded hardware products, including Dell-branded peripheral products.

What is not covered by this limited warranty?

This limited warranty does not cover:

- Software, including the operating system and software added to the Dell-branded hardware products through our factory-integration system, third-party software, or the reloading of software
- Non-Dell-branded and Solution Provider Direct products and accessories
- Problems that result from:
 - External causes such as accident, abuse, misuse, or problems with electrical power
 - Servicing not authorized by Dell
 - Usage that is not in accordance with product instructions
 - Failure to follow the product instructions or failure to perform preventive maintenance
 - Problems caused by using accessories, parts, or components not supplied by Dell
- Products with missing or altered Service Tags or serial numbers
- Products for which Dell has not received payment

THIS WARRANTY GIVES YOU SPECIFIC LEGAL RIGHTS, AND YOU MAY ALSO HAVE OTHER RIGHTS WHICH VARY FROM STATE TO STATE (OR JURISDICTION TO JURISDICTION). DELL'S RESPONSIBILITY FOR MALFUNCTIONS AND DEFECTS IN HARDWARE IS LIMITED TO REPAIR AND REPLACEMENT AS SET FORTH IN THIS WARRANTY STATEMENT. ALL EXPRESS AND IMPLIED WARRANTIES FOR THE PRODUCT, INCLUDING BUT NOT LIMITED TO ANY IMPLIED WARRANTIES AND CONDITIONS OF MERCHANTABILITY AND FITNESS FOR A PARTICULAR PURPOSE, ARE LIMITED IN TIME TO THE TERM OF THE LIMITED WARRANTY PERIOD REFLECTED ON YOUR PACKING SLIP OR INVOICE. NO WARRANTIES, WHETHER EXPRESS OR IMPLIED, WILL APPLY AFTER THE LIMITED WARRANTY PERIOD HAS EXPIRED. SOME STATES DO NOT ALLOW LIMITATIONS ON HOW LONG AN IMPLIED WARRANTY LASTS, SO THIS LIMITATION MAY NOT APPLY TO YOU.

WE DO NOT ACCEPT LIABILITY BEYOND THE REMEDIES PROVIDED FOR IN THIS LIMITED WARRANTY OR FOR CONSEQUENTIAL OR INCIDENTAL DAMAGES, INCLUDING, WITHOUT LIMITATION, ANY LIABILITY FOR THIRD-PARTY CLAIMS AGAINST YOU FOR DAMAGES, FOR PRODUCTS NOT BEING AVAILABLE FOR USE, OR FOR LOST DATA OR LOST SOFTWARE. OUR LIABILITY WILL BE NO MORE THAN THE AMOUNT YOU PAID FOR THE PRODUCT THAT IS THE SUBJECT OF A CLAIM. THIS IS THE MAXIMUM AMOUNT FOR WHICH WE ARE RESPONSIBLE.

SOME STATES DO NOT ALLOW THE EXCLUSION OR LIMITATION OF INCIDENTAL OR CONSEQUENTIAL DAMAGES, SO THE ABOVE LIMITATION OR EXCLUSION MAY NOT APPLY TO YOU.

How long does this limited warranty last?

This limited warranty lasts for the time period indicated on your packing slip or invoice, except for the following Dell-branded hardware:

- Portable computer batteries carry a 1-year limited warranty.
- Projector lamps carry a 90-day limited warranty.
- Memory carries a lifetime limited warranty.
- Monitors carry the longer of either a 3-year limited warranty or the remainder of the warranty for the Dell computer to which the monitor will be connected.

- Other add-on hardware carries the longer of either a 1-year limited warranty for new parts and a 90-day limited warranty for reconditioned parts or, for both new and reconditioned parts, the remainder of the warranty for the Dell computer on which such parts are installed.

The limited warranty on all Dell-branded products begins on the date of the packing slip or invoice. The warranty period is not extended if we repair or replace a warranted product or any parts. Dell may change the availability of limited warranties, at its discretion, but any changes will not be retroactive.

What do I do if I need warranty service?

Before the warranty expires, please call us at the relevant number listed in the following table. Please also have your Dell Service Tag or order number available.

Individual Home Consumers:	U.S. Only
Technical Support	1-800-624-9896
Customer Service	1-800-624-9897
Individual Home Consumers who purchased through an Employee Purchase Program:	
Technical Support and Customer Service	1-800-822-8965
Home and Small Business Commercial Customers:	
Technical Support and Customer Service	1-800-456-3355
Medium, Large, or Global Commercial Customers, Healthcare Customers, and Value-Added Resellers (VARs):	
Technical Support and Customer Service	1-877-459-7298
Government and Education Customers:	
Technical Support and Customer Service	1-877-459-7298
Dell-Branded Memory	1-888-363-5150

What will Dell do?

During the 90 days of the 90-day limited warranty and the first year of all other limited warranties: During the 90 days of the 90-day limited warranty and the first year of all other limited warranties, we will repair any Dell-branded hardware products returned to us that prove to be defective in materials or workmanship. If we are not able to repair the product, we will replace it with a comparable product that is new or refurbished.

When you contact us, we will issue a Return Material Authorization Number for you to include with your return. You must return the products to us in their original or equivalent packaging, prepay shipping charges, and insure the shipment or accept the risk if the product is lost or damaged in shipment. We will return the repaired or replacement products to you. We will pay to ship the repaired or replaced products to you if you use an address in the United States (excluding Puerto Rico and U.S. possessions and territories). Otherwise, we will ship the product to you freight collect.

If we determine that the product is not covered under this warranty, we will notify you and inform you of service alternatives that are available to you on a fee basis.

NOTE: Before you ship the product(s) to us, make sure to back up the data on the hard drive(s) and any other storage device(s) in the product(s). Remove any confidential, proprietary, or personal information and removable media such as floppy disks, CDs, or PC Cards. We are not responsible for any of your confidential, proprietary, or personal information; lost or corrupted data; or damaged or lost removable media.

During the remaining years: For the remaining period of the limited warranty, we will replace any defective part with new or refurbished parts, if we agree that it needs to be replaced. When you contact us, we will require a valid credit card number at the time you request a replacement part, but we will not charge you for the replacement part as long as you return the original part to us within 30 days after we ship the replacement part to you. If we do not receive the original part within 30 days, we will charge to your credit card the then-current standard price for that part.

We will pay to ship the part to you if you use an address in the United States (excluding Puerto Rico and U.S. possessions and territories). Otherwise, we will ship the part freight collect. We will also include a prepaid shipping container with each replacement part for your use in returning the replaced part to us.

NOTE: Before you replace parts, make sure to back up the data on the hard drive(s) and any other storage device(s) in the product(s). We are not responsible for lost or corrupted data.

What if I purchased a service contract?

If your service contract is with Dell, service will be provided to you under the terms of the service agreement. Please refer to that contract for details on how to obtain service.

If you purchased through us a service contract with one of our third-party service providers, please refer to that contract for details on how to obtain service.

How will you fix my product?

We use new and refurbished parts made by various manufacturers in performing warranty repairs and in building replacement parts and systems. Refurbished parts and systems are parts or systems that have been returned to Dell, some of which were never used by a customer. All parts and systems are inspected and tested for quality. Replacement parts and systems are covered for the remaining period of the limited warranty for the product you bought. Dell owns all parts removed from repaired products.

May I transfer the limited warranty?

Limited warranties on systems may be transferred if the current owner transfers ownership of the system and records the transfer with us. The limited warranty on Dell-branded memory may not be transferred. You may record your transfer by going to Dell's website:

- If you are an Individual Home Consumer, go to www.dell.com/us/en/dhs/topics/sbtopic_015_ccare.htm
- If you are a Home Office, Small, Medium, Large, or Global Commercial Customer, go to www.dell.com/us/en/biz/topics/sbtopic_ccare_nav_015_ccare.htm
- If you are a Government, Education, or Healthcare Customer, or an Individual Home Consumer who purchased through an Employee Purchase Program, go to www.dell.com/us/en/pub/topics/sbtopic_015_ccare.htm

If you do not have Internet access, call your customer care representative or call 1-800-624-9897.

"Total Satisfaction" Return Policy (U.S. Only)

We value our relationship with you and want to make sure that you're satisfied with your purchases. That's why we offer a "Total Satisfaction" return policy for most products that you—the end-user customer—purchase directly from Dell. Under this policy, you may return to Dell products that you purchased directly from Dell for a credit or a refund of the purchase price paid, less shipping and handling and applicable return fees as follows:

- **New Hardware Products and Accessories** — Unless you have a separate agreement with Dell, all hardware, accessories, peripherals, parts, and unopened software still in its sealed package, excluding the products listed below, may be returned within twenty-one (21) days from the date on the packing slip or invoice. New PowerEdge™, PowerConnect™ and PowerVault™ products may be returned within thirty (30) days from the date on the packing slip or invoice except that new PowerEdge™ SC servers and n series products purchased from the Small and Medium Business Sales Division may only be returned within fourteen (14) days from the date on the packing slip or invoice. To return applications software or an operating system that has been installed by Dell, you must return the entire computer. A different return policy applies to nondefective products purchased through Dell's Software and Peripherals division by customers of our Small and Medium Business divisions. Those products may be returned within (twenty-one) 21 days from the date on the packing slip or invoice, but a fifteen percent (15%) return fee will be deducted from any refund or credit. The "Total Satisfaction" Return Policy and Software and Peripherals division return policy are not available for Dell | EMC storage products, EMC-branded products, Unisys-branded products, PowerVault™ 160T tape libraries, or enterprise software, non-Dell branded enterprise products, software and/or software licenses purchased under any type of volume purchase agreement or any non-Dell customized hardware and/or software product(s).
- **Reconditioned or Refurbished Dell-Branded Hardware Products and Parts** — All reconditioned or refurbished PowerEdge™, PowerConnect™ and Power Vault™ products may be returned within thirty (30) days from the date on the packing slip or invoice. All other reconditioned or refurbished Dell-branded hardware products and parts may be returned within fourteen (14) days of the date on the packing slip or invoice.

How to Return

To return products, e-mail or call Dell customer service to receive a Credit Return Authorization Number within the return policy period applicable to the product you want to return. You must obtain a Credit Return Authorization Number in order to return the product. See "Contacting Dell" or "Getting Help" in your customer documentation (or www.dell.com/us/en/gen/contact.htm) to find the appropriate contact information for obtaining customer assistance.

You must ship the products to Dell within five (5) days of the date that Dell issues the Credit Return Authorization Number. You must also return the products to Dell in their original packaging, in as-new condition along with any media, documentation, and all other items that were included in the original shipment, prepay shipping charges, and insure the shipment or accept the risk of loss or damage during shipment.

Limited Warranty Terms for Dell-Branded Hardware Products (Canada Only)

What is covered by this limited warranty?

This limited warranty covers defects in materials and workmanship in your—our end-user customer's—Dell-branded hardware products, including Dell-branded peripheral products.

What is not covered by this limited warranty?

This limited warranty does not cover:

- Software, including the operating system and software added to the Dell-branded hardware products through our factory-integration system, or the reloading of the software
- Non-Dell branded and Solution Provider Direct products and accessories
- Problems that result from:
 - External causes such as accident, abuse, misuse, or problems with electrical power
 - Servicing not authorized by Dell
 - Usage that is not in accordance with product instructions
 - Failure to follow the product instructions or failure to perform preventive maintenance
 - Problems caused by using accessories, parts, or components not supplied by Dell
- Products with missing or altered Service Tags or serial numbers
- Products for which Dell has not received payment

THIS WARRANTY GIVES YOU SPECIFIC LEGAL RIGHTS, AND YOU MAY ALSO HAVE OTHER RIGHTS WHICH VARY FROM PROVINCE TO PROVINCE. DELL'S RESPONSIBILITY FOR MALFUNCTIONS AND DEFECTS IN PRODUCT IS LIMITED TO REPAIR AND REPLACEMENT AS SET FORTH IN THIS WARRANTY STATEMENT, FOR THE TERM OF THE WARRANTY PERIOD REFLECTED ON YOUR PACKING SLIP OR INVOICE. EXCEPT FOR THE EXPRESS WARRANTIES CONTAINED IN THIS WARRANTY STATEMENT, DELL DISCLAIMS ALL OTHER WARRANTIES AND CONDITIONS, EXPRESS OR IMPLIED, INCLUDING WITHOUT LIMITATION IMPLIED WARRANTIES AND CONDITIONS OF MERCHANTABILITY AND FITNESS FOR A PARTICULAR PURPOSE, STATUTORY OR OTHERWISE. SOME PROVINCES DO NOT ALLOW THE EXCLUSION OF CERTAIN IMPLIED WARRANTIES OR CONDITIONS, OR LIMITATIONS ON HOW LONG AN IMPLIED WARRANTY OR CONDITION LASTS. THEREFORE, THE FOREGOING EXCLUSIONS AND LIMITATIONS MAY NOT APPLY TO YOU.

WE DO NOT ACCEPT LIABILITY BEYOND THE REMEDIES PROVIDED FOR IN THIS WARRANTY STATEMENT OR FOR SPECIAL, INDIRECT, CONSEQUENTIAL, OR INCIDENTAL DAMAGES, INCLUDING, WITHOUT LIMITATION, ANY LIABILITY FOR THIRD-PARTY CLAIMS AGAINST YOU FOR DAMAGES, FOR PRODUCTS NOT BEING AVAILABLE FOR USE, OR FOR LOST DATA OR LOST SOFTWARE. OUR LIABILITY WILL BE NO MORE THAN THE AMOUNT YOU PAID FOR THE PRODUCT THAT IS THE SUBJECT OF A CLAIM. THIS IS THE MAXIMUM AMOUNT FOR WHICH WE ARE RESPONSIBLE.

SOME PROVINCES DO NOT ALLOW THE EXCLUSION OR LIMITATION OF SPECIAL, INDIRECT, INCIDENTAL, OR CONSEQUENTIAL DAMAGES, SO THE ABOVE LIMITATION OR EXCLUSION MAY NOT APPLY TO YOU.

How long does this limited warranty last?

This limited warranty lasts for the time period indicated on your packing slip or invoice, except that the limited warranty on Dell-branded batteries lasts only 1 year and the limited warranty on the lamps for Dell-branded projectors lasts only 90 days. The limited warranty begins on the date of the packing slip or invoice. The warranty period is not extended if we repair or replace a warranted product or any parts. Dell may change the terms and availability of limited warranties, at its discretion, but any changes will not be retroactive (that is, the warranty terms in place at the time of purchase will apply to your purchase).

What do I do if I need warranty service?

Before the warranty expires, please call us at the relevant number listed in the following table. Please also have your Dell Service Tag or order number available.

Individual Home Consumers; Home Office and Small Business Customers:	Canada Only
Technical Support and Customer Service	1-800-847-4096
Medium, Large, and Global Commercial Customers; Government, Education, and Healthcare Customers; and Value-Added Resellers (VARs):	
Technical Support	1-800-387-5757
Customer Service	1-800-326-9463
Government or Education Customers, or Individual Home Consumers who purchased through an Employee Purchase Program:	
Technical Support	1-800-387-5757
Customer Service	1-800-326-9463 (Extension 8221 for Individual Consumers)
Dell-Branded Memory	1-888-363-5150

What will Dell do?

During the 90 days of the 90-day limited warranty and the first year of all other limited warranties: During the 90 days of the 90-day limited warranty and the first year of all other limited warranties, we will repair any Dell-branded hardware products returned to us that prove to be defective in materials or workmanship. If we are not able to repair the product, we will replace it with a comparable product that is new or refurbished.

When you contact us, we will issue a Return Material Authorization Number for you to include with your return. You must return the products to us in their original or equivalent packaging, prepay shipping charges, and insure the shipment or accept the risk if the product is lost or damaged in shipment. We will return the repaired or replacement products to you. We will pay to ship the repaired or replaced products to you if you use an address in Canada. Otherwise, we will ship the product to you freight collect.

If we determine that the problem is not covered under this warranty, we will notify you and inform you of service alternatives that are available to you on a fee basis.

NOTE: Before you ship the product(s) to us, make sure to back up the data on the hard drive(s) and any other storage device(s) in the product(s). Remove any confidential, proprietary or personal information, removable media, such as floppy disks, CDs, or PC Cards. We are not responsible for any of your confidential, proprietary or personal information; lost or corrupted data; or damaged or lost removable media.

During the remaining years following the first year of all limited warranties: We will replace any defective part with new or refurbished parts, if we agree that it needs to be replaced. When you contact us, we will require a valid credit card number at the time you request a replacement part, but we will not charge you for the replacement part as long as you return the original part to us within days after we ship the replacement part to you. If we do not receive the original part within 30 days, we will charge to your credit card the then-current standard price for that part.

We will pay to ship the part to you if you use an address in Canada. Otherwise, we will ship the part freight collect. We will also include a prepaid shipping container with each replacement part for your use in returning the replaced part to us.

NOTE: Before you replace parts, make sure to back up the data on the hard drive(s) and any other storage device(s) in the product(s). We are not responsible for lost or corrupted data.

What if I purchased a service contract?

If your service contract is with Dell, service will be provided to you under the terms of the service contract. Please refer to that contract for details on how to obtain service. Dell's service contracts can be found online at www.dell.ca or by calling Customer Care at 1-800-847-4096. If you purchased through us a service contract with one of our third-party service providers, please refer to that contract (mailed to you with your packing slip or invoice) for details on how to obtain service.

How will you fix my product?

We use new and refurbished parts made by various manufacturers in performing warranty repairs and in building replacement parts and systems. Refurbished parts and systems are parts or systems that have been returned to Dell, some of which were never used by a customer. All parts and systems are inspected and tested for quality. Replacement parts and systems are covered for the remaining period of the limited warranty for the product you bought. Dell owns all parts removed from repaired products.

May I transfer the limited warranty?

Limited warranties on systems may be transferred if the current owner transfers ownership of the system and records the transfer with us. The limited warranty on Dell-branded memory may not be transferred. You may record your transfer by going to Dell's website:

- For Canada-purchased computers (in-country transfers) and to transfer from one customer to another, go to www.dell.ca/ca/en/gen/topics/segtopic_ccare_nav_013_ccare.htm
- For out-of-country transfers (outside of the original country of purchase), go to www.dell.com/us/en/biz/topics/sbtopic_ccare_nav_016_ccare.htm

If you do not have Internet access, call Dell at 1-800-847-4096 (Home Consumer customers) or 1-800-326-9463 (Corporate Commercial or Government customers).

"Total Satisfaction" Return Policy (Canada Only)

If you are an end-user customer who bought new products directly from Dell, you may return them to Dell up to 30 days after you receive them for a refund or credit of the product purchase price. If you are an end-user customer who bought reconditioned or refurbished products from Dell, you may return them to Dell within 14 days after the date on the packing slip or invoice for a refund or credit of the product purchase price. In either case, the refund or credit will not include any shipping and handling charges shown on your packing slip or invoice and will be subject to a fifteen percent (15%) restocking fee, unless otherwise prohibited by law. If you are an organization that bought the products under a written agreement with Dell, the agreement may contain different terms for the return of products than specified by this policy.

To return products, you must call Dell Customer Service at 1-800-847-4096 to receive a Credit Return Authorization Number. To expedite the process of your refund or credit, Dell expects you to return the products to Dell in their original packaging within 5 days of the date that Dell issues the Credit Return Authorization Number. You must also prepay shipping charges and insure the shipment or accept the risk of loss or damage during shipment. You may return software for a refund or credit only if the sealed package containing the floppy disk(s) or CD(s) is unopened. Returned products must be in as-new condition, and all of the manuals, floppy disk(s), CD(s), power cables, and other items included with a product must be returned with it. For customers who want to return, for refund or credit only, either application or operating system software that has been installed by Dell, the whole system must be returned, along with any media and documentation that may have been included in the original shipment.

The "Total Satisfaction" Return Policy does not apply to Dell | EMC storage products. It also does not apply to products purchased through Dell's Software and Peripherals division. For those products, please instead refer to Dell's Software and Peripheral's then-current return policy (see the following section, "Dell Software and Peripherals [Canada Only]").

Dell Software and Peripherals (Canada Only)

Third-Party Software and Peripherals Products

Similar to other resellers of software and peripherals, Dell does not warrant third-party products. Third-party software and peripheral products are covered by the warranties provided by the original manufacturer or publisher only. Third-party manufacturer warranties vary from product to product. Consult your product documentation for specific warranty information. More information may also be available from the manufacturer or publisher.

While Dell offers a wide selection of software and peripheral products, we do not specifically test or guarantee that all of the products we offer work with any or all of the various models of Dell computers, nor do we test or guarantee all of the products we sell on the hundreds of different brands of computers available today. If you have questions about compatibility, we recommend and encourage you to contact the third-party software and peripheral product manufacturer or publisher directly.

Dell-Branded Peripheral Products

Dell does provide a limited warranty for new Dell-branded peripheral products (products for which Dell is listed as the manufacturer) such as monitors, batteries, memory, docking stations, and projectors. To determine which limited warranty applies to the product you purchased, see the Dell packing slip or invoice and/or the product documentation that accompanied your product. Descriptions of Dell's limited warranties are described in preceding sections.

Return Policy

If you are an end-user customer who bought Dell Software and Peripherals products directly from a Dell company, you may return Dell Software and Peripherals products that are in as-new condition to Dell up to 30 days from the date on the packing slip or invoice for a refund of the product purchase price if already paid. This refund will not include any shipping and handling charges shown on your packing slip or invoice; you are responsible for those.

To return products, you must call Dell Customer Service at 1-800-387-5759 to receive a Credit Return Authorization Number. You must ship the Dell Software and Peripherals products back to Dell in their original manufacturer's packaging (which must be in as-new condition), prepay shipping charges, and insure the shipment or accept the risk of loss or damage during shipment.

To qualify for refund or replacement, returned products must be in as-new condition, software products must be unopened, and all of the manuals, floppy disk(s), CD(s), power cables, and other items included with a product must be returned with it.

1-Year End-User Manufacturer Guarantee (Latin America and the Caribbean Only)

Guarantee

Dell Computer Corporation ("Dell") warrants to the end user in accordance with the following provisions that its branded hardware products, purchased by the end user from a Dell company or an authorized Dell distributor in Latin America or the Caribbean, will be free from defects in materials, workmanship, and design affecting normal use, for a period of 1 year from the original purchase date. Products for which proper claims are made will, at Dell's option, be repaired or replaced at Dell's expense. Dell owns all parts removed from repaired products. Dell uses new and reconditioned parts made by various manufacturers in performing repairs and building replacement products.

Exclusions

This Guarantee does not apply to defects resulting from: improper or inadequate installation, use, or maintenance; actions or modifications by unauthorized third parties or the end user; accidental or willful damage; or normal wear and tear.

Making a Claim

Claims must be made in Latin America or the Caribbean by contacting the Dell point of sale within the guarantee period. The end user must always supply proof of purchase, indicating name and address of the seller, date of purchase, model and serial number, name and address of the customer, and details of symptoms and configuration at the time of malfunction, including peripherals and software used. Otherwise, Dell may refuse the guarantee claim. Upon diagnosis of a warranted defect, Dell will make arrangements and pay for ground freight and insurance to and from Dell's repair/replacement center. The end user must ensure that the defective product is available for collection properly packed in original or equally protective packaging together with the details listed above and the return number provided to the end user by Dell.

Limitation and Statutory Rights

Dell makes no other warranty, guarantee or like statement other than as explicitly stated above, and this Guarantee is given in place of all other guarantees whatsoever, to the fullest extent permitted by law. In the absence of applicable legislation, this Guarantee will be the end user's sole and exclusive remedy against Dell or any of its affiliates, and neither Dell nor any of its affiliates shall be liable for loss of profit or contracts, or any other indirect or consequential loss arising from negligence, breach of contract, or howsoever.

This Guarantee does not impair or affect mandatory statutory rights of the end user against and/or any rights resulting from other contracts concluded by the end user with Dell and/or any other seller.

Dell World Trade LP

One Dell Way, Round Rock, TX 78682, USA

Dell Computadores do Brasil Ltda (CNPJ No. 72.381.189/0001-10)

Avenida Industrial Belgraf, 400
92990-000 - Eldorado do Sul – RS - Brasil

Dell Computer de Chile Ltda

Coyancura 2283, Piso 3- Of.302,
Providencia, Santiago - Chile

Dell Computer de Colombia Corporation

Carrera 7 #115-33 Oficina 603
Bogota, Colombia

Dell Computer de Mexico SA de CV
Paseo de la Reforma 2620 - 11° Piso
Col. Lomas Altas
11950 México, D.F.

Dell Inc. Ink and Toner Cartridges Limited Warranties

The following sections describe the limited warranty for ink and toner cartridges for the U.S., Canada, and Latin America. Refer to the appropriate limited warranty accordingly.

Ink and Toner Cartridges Limited Warranty (U.S. and Canada Only)

Dell Inc. warrants to the original purchaser of genuine Dell-branded toner cartridges that they will be free from defects in material and workmanship for the life of the cartridge and that for genuine Dell-branded ink cartridges they will be free from defects in material and workmanship for two years beginning on the date of invoice. If this product proves defective in either material or workmanship, it will be replaced without charge during the limited warranty period if returned to Dell. You must first call our toll-free number to get your return authorization. In the U.S., call 1-800-822-8965; in Canada, call 1-800-387-5757. If we are not able to replace the product because it has been discontinued or is not available, we will either replace it with a comparable product or reimburse you for the cartridge purchase cost, at Dell's sole option. This limited warranty does not apply to ink or toner cartridges that have been refilled or improperly stored or due to problems resulting from misuse, abuse, accident, neglect, mishandling, incorrect environments, or wear from ordinary use.

THIS WARRANTY GIVES YOU SPECIFIC LEGAL RIGHTS, AND YOU MAY ALSO HAVE OTHER RIGHTS WHICH VARY FROM STATE TO STATE (OR JURISDICTION TO JURISDICTION). DELL'S RESPONSIBILITY FOR MALFUNCTIONS AND DEFECTS IN HARDWARE IS LIMITED TO REPLACEMENT AS SET FORTH IN THIS WARRANTY STATEMENT. FOR CANADIAN CUSTOMERS, EXCEPT FOR THE EXPRESS WARRANTIES CONTAINED IN THIS WARRANTY STATEMENT, DELL DISCLAIMS ALL OTHER WARRANTIES AND CONDITIONS, EXPRESS OR IMPLIED, STATUTORY OR OTHERWISE, FOR THE PRODUCT. FOR U.S. CUSTOMERS, ALL EXPRESS AND IMPLIED WARRANTIES FOR THE PRODUCT, INCLUDING BUT NOT LIMITED TO ANY IMPLIED WARRANTIES AND CONDITIONS OF MERCHANTABILITY AND FITNESS FOR A PARTICULAR PURPOSE ARE LIMITED IN TIME TO THE TERM OF THIS LIMITED WARRANTY. NO WARRANTIES, WHETHER EXPRESS OR IMPLIED, WILL APPLY AFTER THE LIMITED WARRANTY PERIOD HAS EXPIRED. SOME STATES OR JURISDICTIONS DO NOT ALLOW THE EXCLUSION OF CERTAIN IMPLIED WARRANTIES OR CONDITIONS, OR LIMITATIONS ON HOW LONG AN IMPLIED WARRANTY OR CONDITION LASTS, SO THIS LIMITATION MAY NOT APPLY TO YOU. THIS WARRANTY COVERAGE TERMINATES IF YOU SELL OR OTHERWISE TRANSFER THIS PRODUCT TO ANOTHER PARTY.

DELL DOES NOT ACCEPT LIABILITY BEYOND THE REMEDIES PROVIDED FOR IN THIS LIMITED WARRANTY OR FOR SPECIAL, INDIRECT, CONSEQUENTIAL OR INCIDENTAL DAMAGES, INCLUDING, WITHOUT LIMITATION, ANY LIABILITY FOR THIRD-PARTY CLAIMS AGAINST YOU FOR DAMAGES, FOR PRODUCTS NOT BEING AVAILABLE FOR USE, OR FOR LOST DATA OR LOST SOFTWARE. DELL'S LIABILITY WILL BE NO MORE THAN THE AMOUNT YOU PAID FOR THE PRODUCT THAT IS THE SUBJECT OF A CLAIM. THIS IS THE MAXIMUM AMOUNT FOR WHICH DELL IS RESPONSIBLE.

SOME STATES OR JURISDICTIONS DO NOT ALLOW THE EXCLUSION OR LIMITATION OF SPECIAL, INDIRECT, INCIDENTAL OR CONSEQUENTIAL DAMAGES, SO THE ABOVE LIMITATION OR EXCLUSION MAY NOT APPLY TO YOU.

Ink and Toner Cartridges Limited Warranty (Latin America Only)

Dell Inc. warrants to the original purchaser of genuine Dell-branded toner cartridges that the cartridges will be free from defects resulting from material or manufacturing process for the life of the cartridge. For the original purchaser of genuine Dell-branded ink cartridges, Dell warrants that the cartridges will be free from defects resulting from material or manufacturing process for one year beginning from the date of delivery.

If this product presents defects resulting from either material or manufacturing process, it will be replaced without charge during the limited warranty period if returned to Dell.

In order to obtain the necessary information to enable the replacement, call the appropriate toll-free number. In Mexico, call 001-877-533-6230; in Puerto Rico, call 1-877-839-5123. In cases in which either the production of the cartridge has been discontinued or the cartridge is not available, Dell reserves the right, at its sole discretion, to choose between replacing it by a similar product or reimbursing you for the purchase cost.

This limited warranty does not apply to ink or toner cartridges that have been refilled or to defects resulting from misuse, abuse, accident, negligence, mishandling, improper storage or exposure to inappropriate environments.

Dell's liability for the malfunction or defect of hardware after the period of the legal warranty (and specifically the period of the legal warranty of defective products stated in the consumer protections rules), is limited to either the substitution of the product or the reimbursement as stated above. This warranty coverage terminates if you sell or otherwise transfer this product to a third party.

Dell does not accept any additional liability for patrimonial, emotional or any other kind of damage caused to the consumer and/or to a third party, which exceeds the established liability either in this limited warranty or in legal rules that may apply.

Dell Software License Agreement

This is a legal agreement between you, the user, and Dell Products, L.P. ("Dell"). This agreement covers all software that is distributed with the Dell product, for which there is no separate license agreement between you and the manufacturer or owner of the software (collectively the "Software"). By opening or breaking the seal on the Software packet(s), installing or downloading the Software, or using the Software that has been preloaded or is embedded in your computer, you agree to be bound by the terms of this agreement. If you do not agree to these terms, promptly return all Software items (disks, written materials, and packaging) and delete any preloaded or embedded Software.

You may use one copy of the Software on only one computer at a time. If you have multiple licenses for the Software, you may use as many copies at any time as you have licenses.

"Use" means loading the Software in temporary memory or permanent storage on the computer. Installation on a network server solely for distribution to other computers is not "use" if (but only if) you have a separate license for each computer to which the Software is distributed. You must ensure that the number of persons using the Software installed on a network server does not exceed the number of licenses that you have. If the number of users of Software installed on a network server will exceed the number of licenses, you must purchase additional licenses until the number of licenses equals the number of users before allowing additional users to use the Software. If you are a commercial customer of Dell or a Dell affiliate, you hereby grant Dell, or an agent selected by Dell, the right to perform an audit of your use of the Software during normal business hours, you agree to cooperate with Dell in such audit, and you agree to provide Dell with all records reasonably related to your use of the Software. The audit will be limited to verification of your compliance with the terms of this agreement.

The Software is protected by United States copyright laws and international treaties. You may make one copy of the Software solely for backup or archival purposes or transfer it to a single hard disk provided you keep the original solely for backup or archival purposes. You may not rent or lease the Software or copy the written materials accompanying the Software, but you may transfer the Software and all accompanying materials on a permanent basis if you retain no copies and the recipient agrees to the terms hereof. Any transfer must include the most recent update and all prior versions. You may not reverse engineer, decompile or disassemble the Software. If the package accompanying your computer contains compact discs, 3.5" and/or 5.25" disks, you may use only the disks appropriate for your computer. You may not use the disks on another computer or network, or loan, rent, lease, or transfer them to another user except as permitted by this agreement.

Limited Warranty

Dell warrants that the Software disks will be free from defects in materials and workmanship under normal use for ninety (90) days from the date you receive them. This warranty is limited to you and is not transferable. Any implied warranties are limited to ninety (90) days from the date you receive the Software. Some jurisdictions do not allow limits on the duration of an implied warranty, so this limitation may not apply to you. The entire liability of Dell and its suppliers, and your exclusive remedy, shall be (a) return of the price paid for the Software or (b) replacement of any disk not meeting this warranty that is sent with a return authorization number to Dell, at your cost and risk. This limited warranty is void if any disk damage has resulted from accident, abuse, misapplication, or service or modification by someone other than Dell. Any replacement disk is warranted for the remaining original warranty period or thirty (30) days, whichever is longer.

Dell does NOT warrant that the functions of the Software will meet your requirements or that operation of the Software will be uninterrupted or error free. You assume responsibility for selecting the Software to achieve your intended results and for the use and results obtained from the Software.

DELL, ON BEHALF OF ITSELF AND ITS SUPPLIERS, DISCLAIMS ALL OTHER WARRANTIES, EXPRESS OR IMPLIED, INCLUDING, BUT NOT LIMITED TO, IMPLIED WARRANTIES OF MERCHANTABILITY AND FITNESS FOR A PARTICULAR PURPOSE, FOR THE SOFTWARE AND ALL ACCOMPANYING WRITTEN MATERIALS. This limited warranty gives you specific legal rights; you may have others, which vary from jurisdiction to jurisdiction.

IN NO EVENT SHALL DELL OR ITS SUPPLIERS BE LIABLE FOR ANY DAMAGES WHATSOEVER (INCLUDING, WITHOUT LIMITATION, DAMAGES FOR LOSS OF BUSINESS PROFITS, BUSINESS INTERRUPTION, LOSS OF BUSINESS INFORMATION, OR OTHER PECUNIARY LOSS) ARISING OUT OF USE OR INABILITY TO USE THE SOFTWARE, EVEN IF ADVISED OF THE POSSIBILITY OF SUCH DAMAGES. Because some jurisdictions do not allow an exclusion or limitation of liability for consequential or incidental damages, the above limitation may not apply to you.

U.S. Government Restricted Rights

The software and documentation are "commercial items" as that term is defined at 48 C.F.R. 2.101, consisting of "commercial computer software" and "commercial computer software documentation" as such terms are used in 48 C.F.R. 12.212. Consistent with 48 C.F.R. 12.212 and 48 C.F.R. 227.7202-1 through 227.7202-4, all U.S. Government end users acquire the software and documentation with only those rights set forth herein. Contractor/manufacturer is Dell Products, L.P., One Dell Way, Round Rock, Texas 78682.

General

This license is effective until terminated. It will terminate upon the conditions set forth above or if you fail to comply with any of its terms. Upon termination, you agree that the Software and accompanying materials, and all copies thereof, will be destroyed. This agreement is governed by the laws of the State of Texas. Each provision of this agreement is severable. If a provision is found to be unenforceable, this finding does not affect the enforceability of the remaining provisions, terms, or conditions of this agreement. This agreement is binding on successors and assigns. Dell agrees and you agree to waive, to the maximum extent permitted by law, any right to a jury trial with respect to the Software or this agreement. Because this waiver may not be effective in some jurisdictions, this waiver may not apply to you. You acknowledge that you have read this agreement, that you understand it, that you agree to be bound by its terms, and that this is the complete and exclusive statement of the agreement between you and Dell regarding the Software.

Regulatory Notices

Electromagnetic Interference (EMI) is any signal or emission, radiated in free space or conducted along power or signal leads, that endangers the functioning of a radio navigation or other safety service or seriously degrades, obstructs, or repeatedly interrupts a licensed radio communications service. Radio communications services include but are not limited to AM/FM commercial broadcast, television, cellular services, radar, air-traffic control, pager, and Personal Communication Services (PCS). These licensed services, along with unintentional radiators such as digital devices, contribute to the electromagnetic environment.

Electromagnetic Compatibility (EMC) is the ability of items of electronic equipment to function properly together in the electronic environment. While this device has been designed and determined to be compliant with regulatory agency limits for EMI, there is no guarantee that interference will not occur in a particular installation. If this equipment does cause interference with radio communications services, which can be determined by turning the equipment off and on, you are encouraged to try to correct the interference by one or more of the following measures:

- Reorient the receiving antenna.
- Relocate the device with respect to the receiver.
- Move the device away from the receiver.
- Plug the device into a different outlet so that the device and the receiver are on different branch circuits.

If necessary, consult a Dell Technical Support representative or an experienced radio/television technician for additional suggestions.

For additional regulatory information, see the User's Guide on your CD.

NOM Information (Mexico Only)

The following information is provided on the device(s) described in this document in compliance with the requirements of the official Mexican standards (NOM):

Exporter:

Dell Inc.
One Dell Way
Round Rock, TX 78682

Importer: Dell Computer de México, S.A. de C.V.
Paseo de la Reforma 2620 - 11° Piso
Col. Lomas Altas
11950 México, D.F.

Ship to: Dell Computer de México, S.A. de C.V.
al Cuidado de Kuehne & Nagel de México S. de
R.L.
Avenida Soles No. 55
Col. Peñon de los Baños
15520 México, D.F.

Model number: 922

Supply voltage: 100/240 VAC

Frequency: 50/60 Hz

Current consumption: 1.0 A

Output voltage: 30 VDC

Output current: 0.5 A

Index

A

aligning ink cartridges, 47

B

Black Copy button, 16

borderless printing, 25

buttons, operator panel

Black Copy, 16

Cancel, 16

Color Copy, 15

down arrow, 16

Power, 16

Scan, 15

up arrow, 16

C

Cancel button, 16

cards

loading, 20

cartridges, ink

aligning, 47

replacing, 44

cleaning

ink cartridge nozzles, 48

Color Copy button, 15

copies, 26

copying

operator panel, 26

software, 27

D

Dell

contacting, 63

Dell All-In-One Center

accessing, 39

Copy section, 39

Creative Tasks section, 40

Preview section, 40

Scan section, 39

using, 39

Dell Picture Studio v2.0

using, 41

Dell Printer Solution Center

accessing, 38

using, 38

E

e-mail

document, 32

scanned image, 32

envelopes

loading, 20

error message

Blinking Power button, 57

Data error, 58

Ink Low Alert, 57

Paper feed, 58

Paper jam, 57

Paper tray empty, 58

Print carrier, 58

Printhead, 58

Reserve tank, 57

Scan carrier, 58

System control, 58

error messages

Ink Low, 57

Paper jam, 57

Paper Out, 58

error messages and flashing
lights, 57

F

faxing, 33

G

glossy paper

loading, 20

greeting cards

loading, 20

I

- index cards
 - loading, 20
- ink cartridges
 - aligning, 47
 - cleaning, 48
 - replacing, 44
- Ink Low message, 57
- iron-on transfers
 - loading, 20

L

- loading
 - cards, 20
 - envelopes, 20
 - greeting cards, 20
 - index cards, 20
 - iron-on transfers, 20
 - photo cards, 20
 - photo paper, 20
 - postcards, 20
 - transparencies, 21

M

- messages, error
 - Ink Low, 57
 - Paper feed, 58
 - Paper jam, 57
 - Paper out, 58
 - Print carrier, 58
 - Printhead, 58
 - Scan carrier, 58
 - System control, 58
- multiple copies, 41

N

- nozzles, ink cartridge
 - cleaning, 48

O

- operator panel
 - copying with, 26
 - using, 15

P

- paper exit tray, 12
- Paper jam message, 57
- Paper out message, 58
- Paper Setup tab, 41
- paper type sensor, 17
 - turning off, 17
- photo cards
 - loading, 20
- photo paper
 - loading, 20
- photos
 - printing, 24
- postcards
 - loading, 20
- Print Layout tab, 41
- Print Properties
 - accessing, 40
 - Paper Setup tab, 41
 - Print Layout tab, 41
 - Quality/Copies tab, 41
- problems
 - drives, 52

Q

- Quality/Copies tab, 41

S

- safety information, 9
- Scan button, 15
- software
 - Dell All-In-One Center, 39
 - Dell Printer Solution Center, 38
 - Print Properties, 40
 - understanding, 38
- specialty media
 - cards, 20
 - envelopes, 20
 - glossy, 20
 - greeting cards, 20
 - index cards, 20
 - iron-on transfers, 20
 - photo cards, 20
 - photo paper, 20
 - postcards, 20
 - transparencies, 21
- support
 - contacting Dell, 63

T

- troubleshooting
 - ink low message, 57
 - out of paper, 57
 - paper out message, 58

W

warranty, 82

Free Manuals Download Website

<http://myh66.com>

<http://usermanuals.us>

<http://www.somanuals.com>

<http://www.4manuals.cc>

<http://www.manual-lib.com>

<http://www.404manual.com>

<http://www.luxmanual.com>

<http://aubethermostatmanual.com>

Golf course search by state

<http://golfingnear.com>

Email search by domain

<http://emailbydomain.com>

Auto manuals search

<http://auto.somanuals.com>

TV manuals search

<http://tv.somanuals.com>