

Dell™ Laser Printer 1700/1700n

Owner's Manual

Look Inside For:

- Setting Up Your Printer
- Loading Paper
- Network Printing
- Understanding the Software

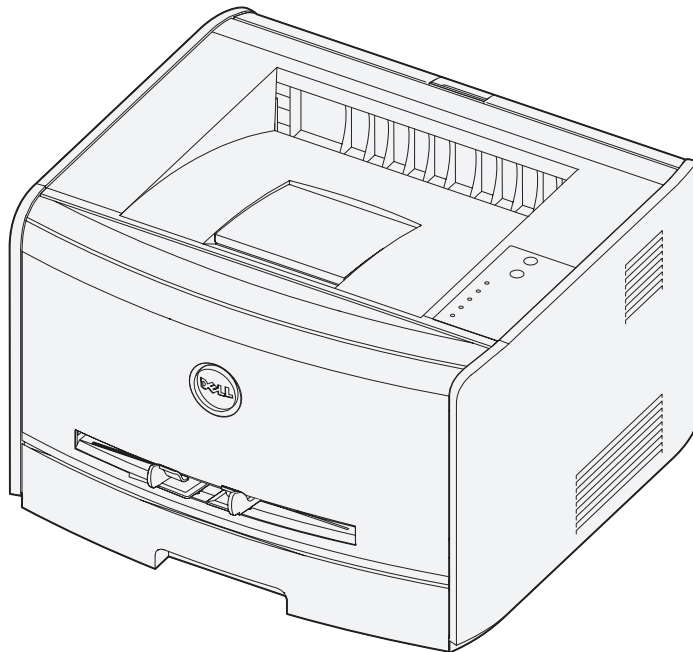

Ordering Supplies

Dell™ toner cartridges are available only through Dell. You can order toner cartridges online at www.dell.com/supplies or by phone.

US	877-INK-2-YOU	Italy	800602705
Australia	1300 303 290	Japan	044-556-3551
Austria	08 20 - 24 05 30 35	Luxembourg	02.713 1590
Belgium	02.713 1590	Mexico	866-851-1754
Canada	1-877-501-4803	Netherlands	020 - 674 4881
Chile	123-0-020-3397 800-20-1385	Norway	231622 64
Colombia	01800-9-155676	Portugal	21 4220710
Denmark	3287 5215	PRC	800-858-0888
Finland	09 2533 1411	Puerto Rico	866-851-1760
France	825387247	Spain	902120385
Germany	0800 2873355	Sweden	08 587 705 81
Ireland	1850 707 407	Switzerland	0848 801 888
		UK	0870 907 4574

 **NOTE:** If your country is not listed, contact your Dell distributor to order supplies.

Dell Laser Printer 1700 Supplies

Supply Item	Part number
3,000 page toner cartridge	00N3769
3,000 page Use and Return toner cartridge	00J3815
6,000 page toner cartridge	00H3730
6,000 page Use and Return toner cartridge	00K3756
Imaging drum	D4283

Dell™ Laser Printer 1700

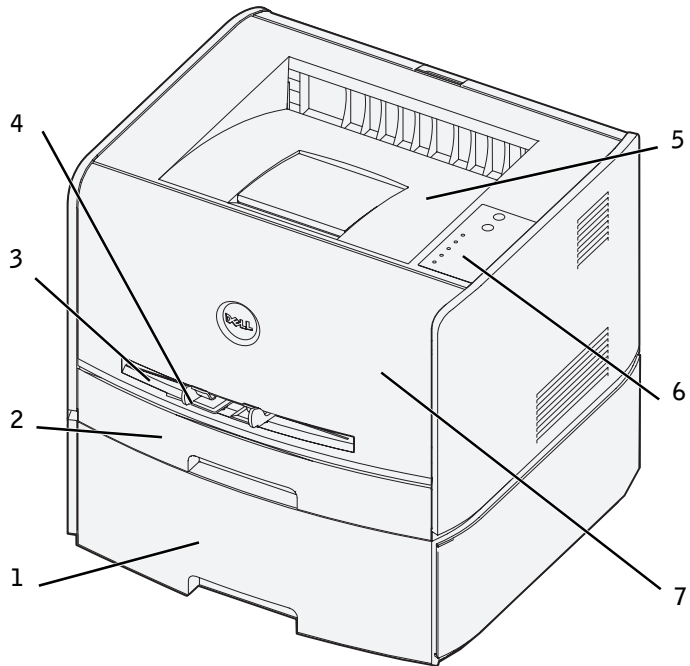

1	Optional 550-sheet tray	5	Output bin
2	250-sheet tray	6	Operator panel
3	Manual feed slot	7	Front cover
4	Paper guide		

Accessing your *User's Guide*

To access your *User's Guide*, click **Start**→**Programs** or **All Programs**→**Dell Printers**→**Dell Laser Printer 1700**→**User's Guide**.

 **NOTE:** You cannot access your *User's Guide* until you have installed the drivers for your printer.

Notes, Notices, and Cautions



NOTE: A NOTE indicates important information that helps you make better use of your printer.



NOTICE: A NOTICE indicates either potential damage to hardware or loss of data and tells you how to avoid the problem.



CAUTION: A CAUTION indicates a potential for property damage, personal injury, or death.

**Information in this document is subject to change without notice.
© 2004 Dell Inc. All rights reserved.**

Reproduction in any manner whatsoever without the written permission of Dell Inc. is strictly forbidden.

Trademarks used in this text: *Dell*, the *DELL* logo, *Inspiron*, *Dell Precision*, *Dimension*, *OptiPlex*, *Latitude*, and *Dell Toner Management System* are trademarks of Dell Inc.; *Intel* and *Pentium* are registered trademarks and *Celeron* is a trademark of Intel Corporation; *Microsoft* and *Windows* are registered trademarks of Microsoft Corporation.

Other trademarks and trade names may be used in this document to refer to either the entities claiming the marks and names or their products. Dell Inc. disclaims any proprietary interest in trademarks and trade names other than its own.

UNITED STATES GOVERNMENT RESTRICTED RIGHTS

This software and documentation are provided with RESTRICTED RIGHTS. Use, duplication or disclosure by the Government is subject to restrictions as set forth in subparagraph (c)(1)(ii) of the Rights in Technical Data and Computer Software clause at DFARS 252.227-7013 and in applicable FAR provisions: Dell Inc., One Dell Way, Round Rock, Texas, 78682, USA.

FCC emissions information

This equipment has been tested and found to comply with the limits for a Class B digital device, pursuant to Part 15 of the FCC rules. Refer to the *Drivers and Utilities* CD for details.

Contents

1 Preparing the Printer

Replacing the Operator Panel Overlay	12
Installing the 550-Sheet Optional Drawer	14
Configuring the Paper Trays	15
Installing an Optional Memory Card	17

2 Loading Paper

Loading the 250-Sheet and 550-Sheet Trays	22
Loading the Manual Feeder	25
Using the Rear Exit	26
Print Media Guidelines	27
Media Types and Sizes	28

3 Setting Up for Local Printing

Local Set-Up	30
Using Windows XP With a USB or Parallel Cable	31
Using Windows 2000 With a USB or Parallel Cable	32
Using Windows NT With a Parallel Cable	33
Using Windows Me With a USB or Parallel Cable	33
Using Windows 98 SE With a USB or Parallel Cable	34

4 Setting Up for Network Printing

Network Set-Up	38
Attach Cables	38
Print and Check the Network Setup Page	39
Run the Installation Software	40

5 Software Overview

Dell™ Toner Management System	44
Status Monitor Center	44
Printing Status Window	44
Printer Supplies Reorder Application	45
Dell Local Printer Settings Utility	45
Set IP Address Utility	45
Dell Printer Software Uninstall	46
Driver Profiler	46
Dell Printer Configuration Web Tool	47

6 Troubleshooting

Basic Problems	50
Replacing the Toner Cartridge	54
Replacing the Imaging Drum	57
Clearing Paper Jams	60

7 Contacting Dell

Technical Assistance	64
Automated Order-Status Service	64
Contacting Dell	65

8 Appendix

Limited Warranties and Return Policy	84
Limited Warranty for Dell-Branded Hardware Products (U.S. Only)	84
"Total Satisfaction" Return Policy (U.S. Only)	87
Limited Warranty Terms for Dell-Branded Hardware Products (Canada Only)	88
"Total Satisfaction" Return Policy (Canada Only)	92
Dell Software and Peripherals (Canada Only)	92
One-Year End-User Manufacturer Guarantee (Latin America and the Caribbean Only)	93
Dell Inc. Ink and Toner Cartridges Limited Warranties	95
Ink and Toner Cartridges Limited Warranty (U.S. and Canada Only)	95
Ink and Toner Cartridges Limited Warranty (Latin America Only)	96
Dell Software License Agreement	97

Index	101
-----------------	-----

CAUTION: SAFETY INFORMATION

Use the following safety guidelines to help ensure your own personal safety and to help protect your system and working environment from potential damage.

- Your product uses a laser.

CAUTION: Use of controls or adjustments or performance of procedures other than those specified herein may result in hazardous radiation exposure.

- Your product uses a printing process that heats the print media, and heat can cause certain media to release emissions. You must understand the section in your operating instructions that discusses the guidelines for selecting appropriate print media to avoid the possibility of harmful emissions.

CAUTION: If your product is *not* marked with this symbol , it *must* be connected to an electrical outlet that is properly grounded.

- The power cord must be connected to an electrical outlet that is near the product and easily accessible.
- Refer service or repairs, other than those described in the operating instructions, to a professional service person.
- This product is designed to meet safety standards with the use of specific Dell-authorized components. The safety features of some parts may not always be obvious. Dell disclaims liability associated with use of non-Dell-authorized components.

SECTION 1

Preparing the Printer

Replacing the Operator Panel Overlay

Installing the 550-Sheet Optional Drawer

Installing an Optional Memory Card

Replacing the Operator Panel Overlay

If you have a non-English operator panel overlay in your printer box and want to use it, follow these steps:

- 1 Open the front cover by pressing the button on the left side of the printer and lowering the cover.

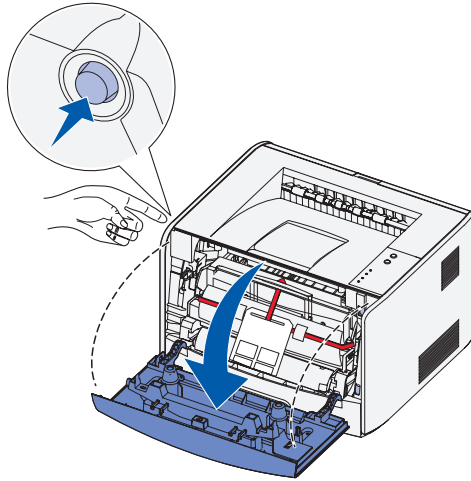

- 2 Remove the English operator panel by pressing the tab and lifting the panel up.

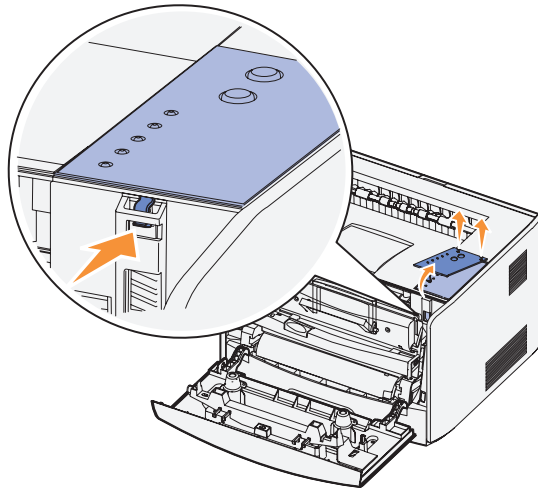

- 3 Snap the non-English operator panel into place.

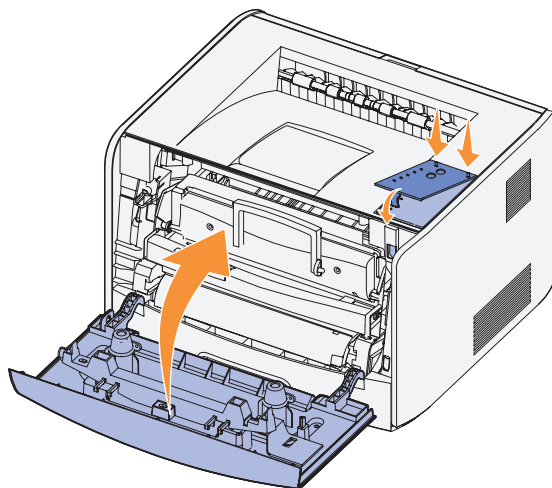

- 4 Close the front cover.

Installing the 550-Sheet Optional Drawer

Your printer supports one optional drawer that lets you load up to 550 sheets of paper.

⚠ CAUTION: If you are installing a 550-sheet drawer after setting up the printer, turn the printer off and unplug the power cord before continuing.

- 1 Unpack the 550-sheet drawer and remove any packing material.
- 2 Place the drawer in the location you have chosen for your printer.

✍ NOTE: If you have optional memory to install, leave clearance on the right side of the printer.

- 3 Align the holes in the printer with the positioning posts on the 550-sheet drawer and lower the printer into place.

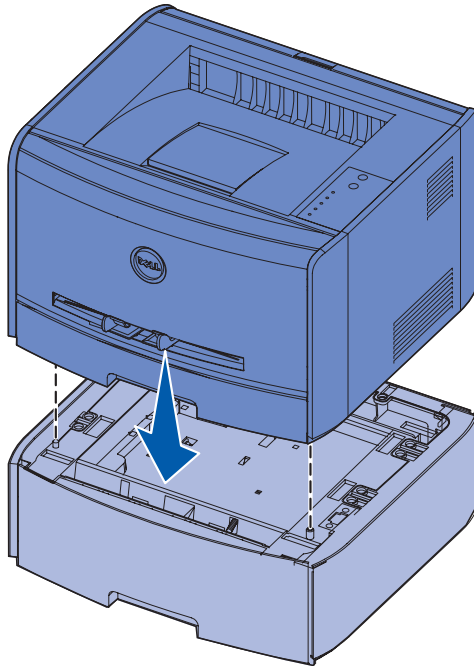

Specifying the media type and size loaded into each tray will help prevent jams. See "Configuring the Paper Trays" on page 15 for more information.

Configuring the Paper Trays

 **NOTE:** You must first install the drivers for your printer before configuring the paper trays. See "Setting Up for Local Printing" on page 29 or "Setting Up for Network Printing" on page 37.

Dell Laser Printer 1700/1700n

- 1 Launch the Dell Local Printer Settings Utility (**Start**→**Programs**→**Dell Printers**→**Dell Laser Printer 1700**→**Dell Local Printer Settings Utility**).
- 2 Select your Dell Laser Printer 1700.
- 3 Click **OK**.
- 4 In the left column, click **Paper**.
- 5 In the right column, go to the Tray 1 section. Specify what size and type of media you loaded into tray 1.
- 6 In the right column, go to the Tray 2 section. Specify what size and type of media you loaded into tray 2.
- 7 On the Menu Bar, click **Actions**→**Apply Settings**.
- 8 Close the utility.

 **NOTE:** If you change the size or type of media loaded into either tray, use the Local Printer Settings Utility to reconfigure the tray.

- 9 To update your printer options, follow the instructions in the table.

Windows XP	<ol style="list-style-type: none">1 Click Start→Control Panel→Printers and Other Hardware→Printers and Faxes.2 Right-click the Dell Laser Printer 1700 icon.3 Click Properties→Installed Options→Ask Printer.4 Click OK→OK. Close the Printers folder.
Windows 2000 Windows NT 4.0	<ol style="list-style-type: none">1 Click Start→Settings→Printers.2 Right-click the Dell Laser Printer 1700 icon.3 Click Properties→Installed Options(or Options)→Ask Printer (or Update Now).4 Click OK→OK. Close the Printers folder.

Windows Me Windows 98 SE	<ol style="list-style-type: none"> 1 Click Start→Settings→Printers. 2 Right-click the Dell Laser Printer 1700 icon. 3 Click Properties→Device (or Features)→Update (or Update Now). 4 Click OK→OK. Close the Printers folder.
-----------------------------	---

If **Update** or **Ask Printer** is unavailable, follow these steps:

- a** In the Available Options list, click **550-sheet tray**.
- b** Click **Add**.
- c** Click **OK**, and then close the Printers folder.

If **Update Now** or **Ask Printer** is unavailable, follow these steps:

- a** In the Options list, find 550-sheet tray.
- b** Change the setting from Not Installed to Installed.
- c** Click **OK**, and then close the Printers folder.

Dell Laser Printer 1700n

Setting the paper size and type for the 1700n printer is done through the Dell Printer Configuration Web Tool.

Use the following steps to change the 1700n printer paper size and type:

- 1** Type your network printer's IP address in your Web browser.



NOTE: If you do not know what your printer's IP address is, print a network setup page, which lists the IP address. For more information, see "Print and Check the Network Setup Page" on page 39.

- 2** When the Printer Status page appears, select **Printer Settings** in the left column.
- 3** Select **Paper Menu** from the Printer Settings page.
- 4** Select **PAPER SIZE**.
- 5** Select the paper size you have in each tray.
- 6** Click **Submit**.
- 7** Select **Printer Settings** in the left column.
- 8** Select **Paper Menu** from the Printer Settings page.
- 9** Select **PAPER TYPE**.

- 10 Select the paper type you have in each tray.
- 11 Click Submit.

Installing an Optional Memory Card

The system board has one connector for an optional memory card. The printer can support up to 128MB (for a total of 160MB for a network printer and 144MB for a non-network printer).

⚠ CAUTION: If you are installing a memory card after setting up the printer, turn the printer off and unplug the power cord before continuing.

- 1 Open the front cover by pressing the button on the left side of the printer and lowering the cover.

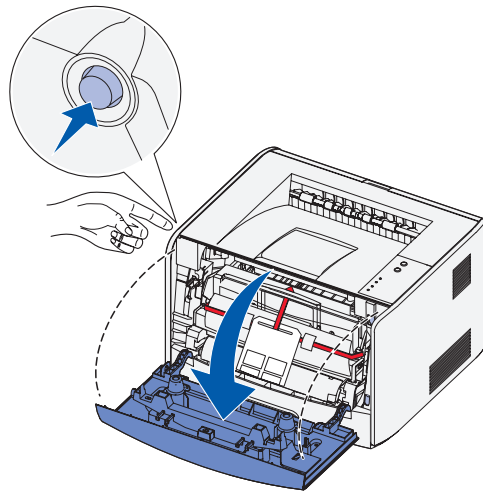

- 2 Open the rear exit.

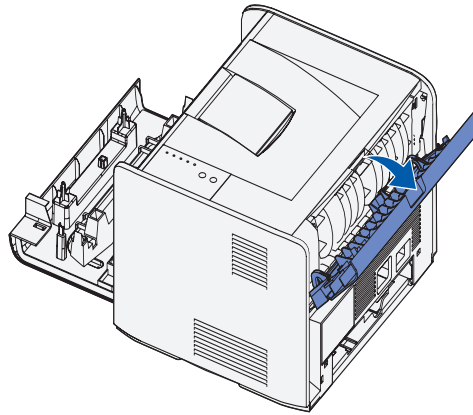

- 3 Open the side cover by pressing the two detents on the front right side of the machine and swinging the cover back.

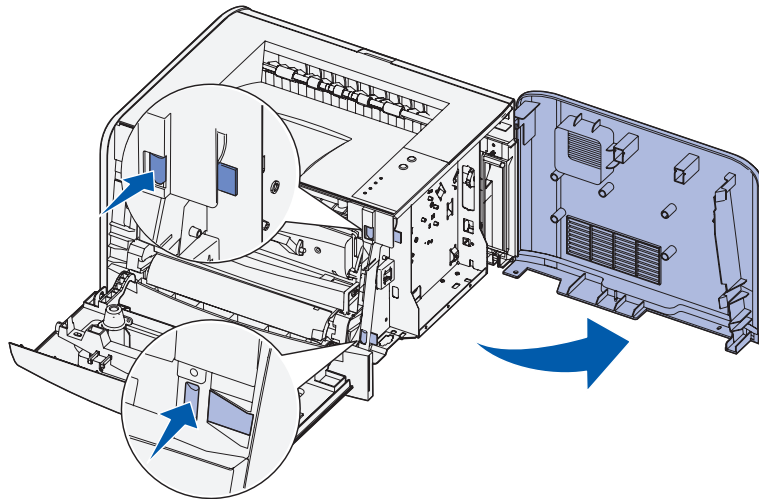

- 4 Push open the latches on both ends of the memory connector.

 **NOTE:** Memory options designed for other printers may not work with your printer.

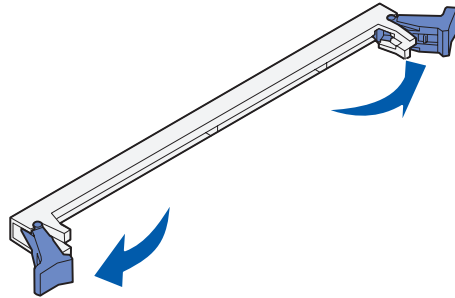

5 Unpack the memory card.

 **NOTICE:** Memory cards are easily damaged by static electricity. Touch something metal, such as the printer frame, before you touch a memory card.

Avoid touching the connection points along the edge of the card.

6 Align the notches on the bottom of the card with the notches on the connector.

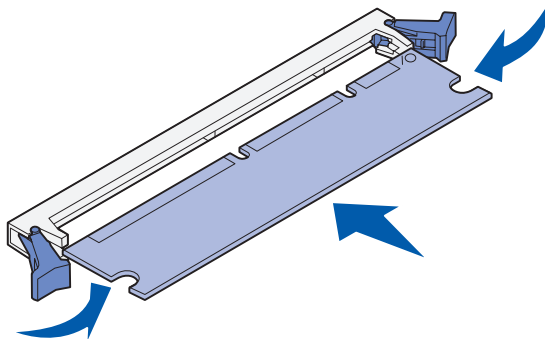

7 Push the memory card firmly into the connector until the latches on either end of the connector *snap* into place.

It may require some force to fully seat the card.

8 Make sure each latch fits over the notch on each end of the card.

9 Close the side cover.

10 Close the rear exit.

11 Close the front cover.

SECTION 2

Loading Paper

Loading the 250-Sheet and 550-Sheet Trays

Loading the Manual Feeder

Using the Rear Exit

Print Media Guidelines

Loading the 250-Sheet and 550-Sheet Trays

Follow these instructions to load paper in the 250-sheet tray and 550-sheet tray.

- 1 Remove the tray.

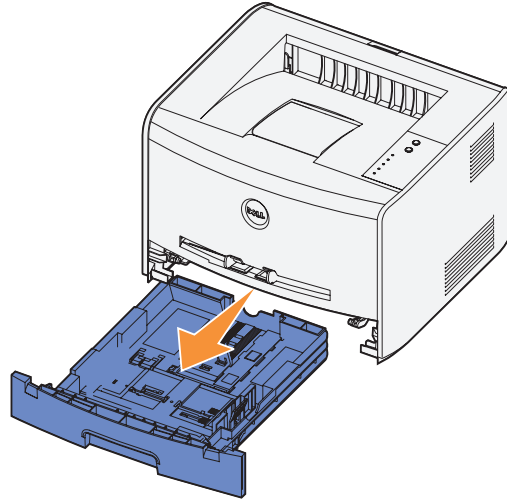

- 2 Prepare a stack of paper for loading by flexing or fanning it back and forth. Straighten the edges on a level surface.

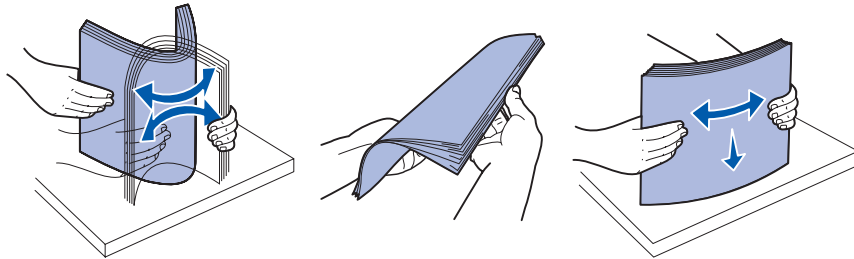

- 3 Load the paper in the tray with the print side facing down.

Make sure the paper is below the max fill line on the side guides. Overloading may cause jams.

- 4 Slide the two side guides and the back guide until they fit snugly against the stack of paper.

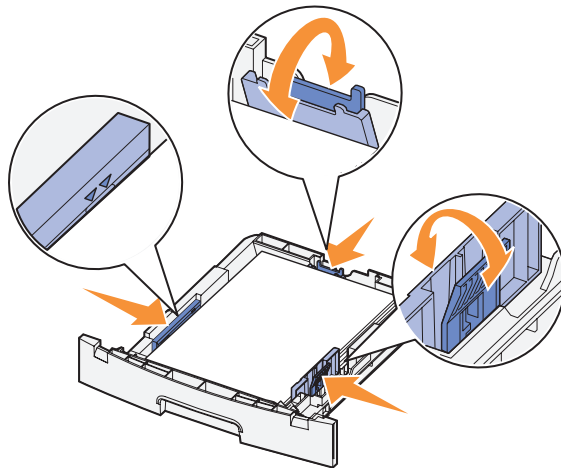

If you are loading legal or folio size paper, press down on the latch at the back of the tray and expand the tray until the extender locks into place.

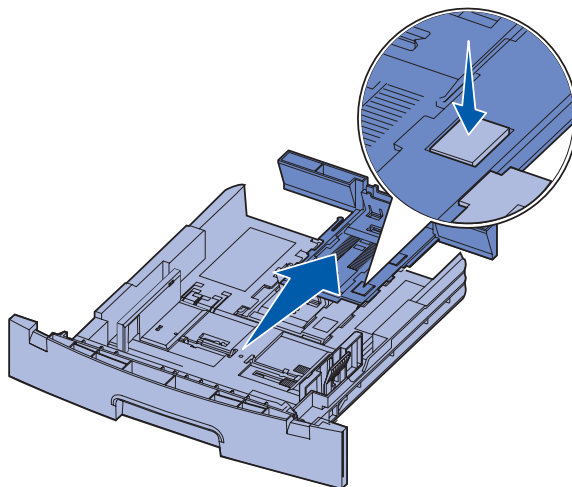

- 5 Insert the tray.

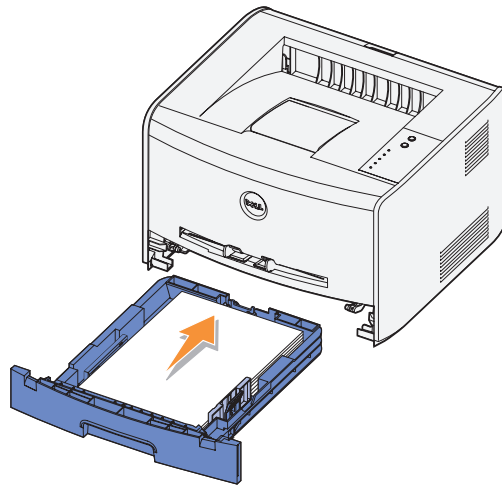

- 6 Extend the paper support on the output bin.

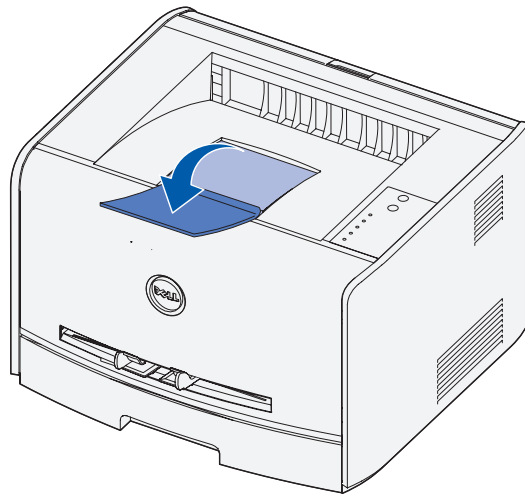

Loading the Manual Feeder

The manual feeder is located at the front of your printer and can only feed one sheet of print media at a time. You can use the manual feeder to make quick runs of paper types or sizes that are not currently loaded in the paper tray.

To load the manual feeder:

- 1 Place a sheet of the selected print media, print side facing up, at the center of the manual feeder, but only to the point where its leading edge can contact the paper guides. Otherwise, the printer will engage the print media too soon and skew the print job.
- 2 Adjust the paper guides to the print media's width.

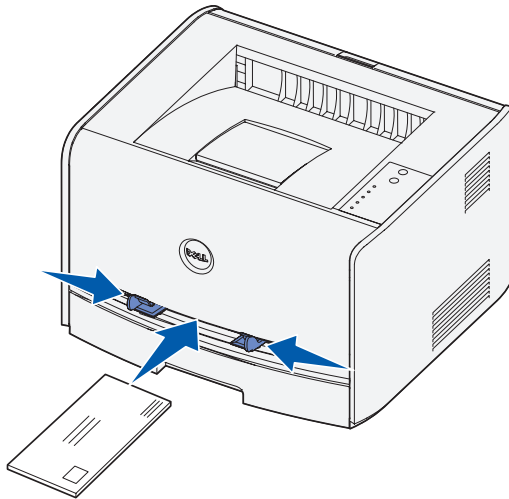

- 3 Hold both sides of the print media close to the manual feeder and push it into the printer until it automatically engages.

There is a brief pause between the time the printer engages the print media and when it feeds into the printer.

NOTICE: Do not force the print media into the feeder. Forcing the media causes jams.

- Insert envelopes with the flap side face down and with the stamp area on the top right side.
- Hold transparencies by the edges and avoid touching the print side. Oils from your fingers that are deposited on the transparency can affect print quality.

- Load letterhead face-up, with the top of the sheet entering the printer first.
- If you experience problems with paper feed, turn the paper around.

Using the Rear Exit

The single-sheet rear exit provides a straight-through paper path to help reduce curling and potential jams. This is especially useful for specialty media, such as transparencies, envelopes, labels, card stock, or index cards.

To use the rear exit, simply open the rear exit door. When the rear exit door is open, all print media comes out the rear exit. When closed, all media is sent to the output bin on top of the printer.

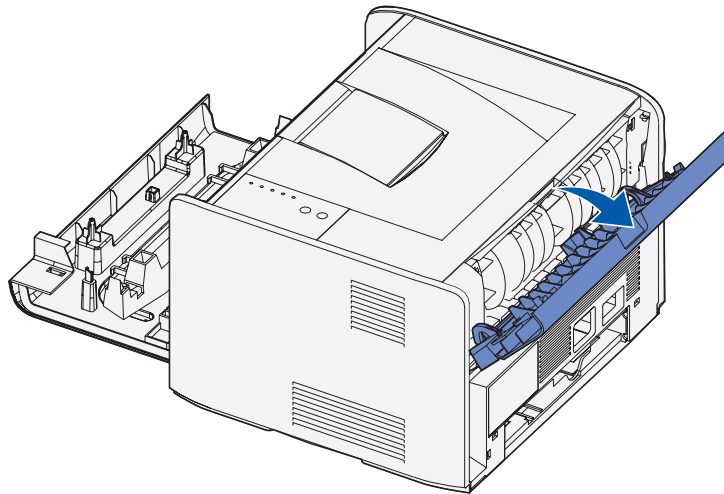

Print Media Guidelines

Selecting the right paper or other media reduces printing problems. For best print quality, try a sample of the paper or specialty media you are considering before buying large quantities.

 **CAUTION: Your product uses a printing process that heats the print media, and heat can cause certain media to release emissions. You must understand the section in your operating instructions that discusses the guidelines for selecting appropriate print media to avoid the possibility of harmful emissions.**

- Use 20 lb (75 g/m²) xerographic paper.
- Use transparencies designed for laser printers.
- Use envelopes made from 24 lb (90 g/m²) bond paper. To reduce paper jams, do not use envelopes that:
 - Have excessive curl
 - Are stuck together
 - Are damaged in any way
 - Contain windows, holes, perforations, cutouts, or embossing
 - Use metal clasps, string ties, or metal folding bars
 - Have postage stamps attached
 - Have any exposed adhesive when the flap is in the sealed position
- Do not use labels that have exposed adhesive on the sheets.
- Do not print a large number of labels continuously.
- Use card stock with a maximum weight of 163 g/m² and a minimum size of 76.2 x 127 mm (3 x 5 in.).

Media Types and Sizes

Media	Size	Weight	Capacity
Paper	A4, A5, B5, letter, legal, executive, folio	17–43 lb (64–163 g/m ²)	Tray 1: 250 sheets (20 lb paper)
		16–43 lb (60–163 g/m ²)	Manual feed: 1 sheet
		16–24 lb (60–90 g/m ²)	Optional 550-sheet tray: 550 sheets (20 lb paper)
Transparencies	A4, letter	N/A	Tray 1: 10 sheets Manual feed: 1 sheet
Envelopes	Monarch (7 3/4), 9, Com-10, C5, B5, DL	24 lb (90 g/m ²)	Tray 1: 10 envelopes Manual feed: 1 envelope
Labels (Paper)	Minimum: 8.3 x 11 in. (210 mm x 279 mm)	17–43 lb (64–163 g/m ²)	Tray 1: 10 sheets Manual feed: 1 sheet
	Maximum: 8.5 x 11.7 in. (216 mm x 297 mm)		
Index Bristol	Minimum: 3 x 5 in. (76.2 x 127 mm)	32–43 lb Index Bristol (120–163 g/m ²)	Tray 1: 10 cards Manual feed: 1 card
	Maximum: 8.5 x 14 in. (216 mm x 356 mm)		

SECTION 3

Setting Up for Local Printing

Local Set-Up

A local printer is a printer attached to one computer using a USB or parallel cable. *If your printer is attached to a network instead of your computer, go to "Setting Up for Network Printing" on page 37.*

Local Set-Up

A printer driver is software that lets your computer communicate with your printer.

If you purchased your Dell printer and computer together, the printer drivers and utilities described in the "Software Overview" on page 43 are automatically installed—you are ready to print!

If you purchased your Dell printer separately, use the *Drivers and Utilities* CD to install all the features described in the "Software Overview" on page 43. Use the following table to find the instructions you need for your operating system.

Computer operating system	Go to...
Windows XP	page 31
Windows 2000	page 32
Windows NT	page 33
Windows Me	page 33
Windows 98 SE	page 34

You need to complete Microsoft's Plug and Play before installing the custom driver from your printer drivers CD.

Using Windows XP With a USB or Parallel Cable



NOTE: Windows XP Professional requires that you have administrative access to install printer drivers on your computer.

When you attached the cable and turned on the printer, the **Found New Hardware Wizard** appeared on your computer screen.

- 1 Insert the *Drivers and Utilities* CD into your computer.

The Wizard automatically searches for an appropriate driver.

- 2 Scroll through the list of drivers until you see `D:\Drivers\Print\win_2kXP\dkaap2da.inf` selected in the Location column (where D is the drive letter of your CD).

- 3 Click **Next**.

The wizard copies all of the necessary files and installs the printer drivers.

- 4 Click **Finish** when the software is installed.

- 5 The *Drivers and Utilities* CD should launch the installation software automatically.

If the CD does not automatically launch, click **Start**→**Run**, type `D:\setup.exe` (where D is the drive letter of your CD), and then click **OK**.

- 6 When the *Drivers and Utilities* CD screen appears, click **Personal Installation - Install the printer for use on this computer only** to install the additional software for your printer.

- 7 Select your printer from the drop-down box.

- 8 Select **Typical Installation (recommended)**, and then click **Install**.

When all of the files are installed on your computer, the Congratulations screen appears.

- 9 Click **Print a Test Page** to verify printer setup.

- 10 Click **Finish** to exit when the test page prints successfully.

Using Windows 2000 With a USB or Parallel Cable

When you attached the cable and turned on the printer, the **Found New Hardware Wizard** appeared on your computer screen.

1 Insert the *Drivers and Utilities* CD, and then click **Next**.

2 Select **Search for a suitable driver**, and then click **Next**.

3 Select **Specify a location only**, and then click **Next**.

4 Browse to the location of the printer driver on the *Drivers and Utilities* CD.

D:\Drivers\Print\Win_2kXP\

Replace D:\ with the letter of your CD-ROM drive (for example, type D:\ where D is the drive letter of your CD).

5 Click **Open**, and then click **OK**.

6 Click **Next** to install the driver that is displayed.

D:\Drivers\Print\Win_2kXP\dkaap2da.inf

7 Click **Finish** when the software is installed.

8 The *Drivers and Utilities* CD should launch the installation software automatically.

If the CD does not automatically launch, click **Start**→**Run**, type **D:\setup.exe** (where D is the drive letter of your CD), and then click **OK**.

9 When the *Drivers and Utilities* CD screen appears, click **Personal Installation - Install the printer for use on this computer only** to install the additional software for your printer.

10 Select your printer from the drop-down box.

11 Select **Typical Installation (recommended)**, and then click **Install**.

When all of the files are installed on your computer, the Congratulations screen appears.

12 Click **Print a Test Page** to verify printer setup.

13 Click **Finish** to exit when the test page prints successfully.

Using Windows NT With a Parallel Cable

 **NOTE:** You need administrative access to install printer drivers on your computer.

- 1 Insert the *Drivers and Utilities* CD.
- 2 When the *Drivers and Utilities* CD screen appears, click **Personal Installation - Install the printer for use on this computer only** to install the additional software for your printer.
- 3 Select your printer from the drop-down box.
- 4 Select **Typical Installation (recommended)**, and then click **Install**.
When all of the files are installed on your computer, the Congratulations screen appears.
- 5 Click **Finish** to exit the *Drivers and Utilities* CD screen.

Using Windows Me With a USB or Parallel Cable

 **NOTE:** Depending on the software and printers already installed on your computer, your screens may vary from those in the instructions.

If you are connecting the printer using a USB cable, you must install both a USB port driver and a custom print driver.

When you attached the cable and turned on the printer and computer, the **Add New Hardware Wizard** screen appeared on your computer screen.

- 1 Insert the *Drivers and Utilities* CD.
If you are using a USB cable, the Wizard automatically searches for the USB driver on the CD and installs it.
If you are using a parallel cable, skip to step 3.
- 2 After the USB port driver is found, click **Finish**.
- 3 Select **Automatic search for the best driver (recommended)**, and then click **Next**.
The wizard searches for a printer driver.
- 4 Select **D:\Drivers\Print\Win_9xme\\dkaag2da.inf** from the list on the screen (where D is the drive letter of your CD), and then click **OK**.
- 5 Click **Next** to install the printer driver.
- 6 Click **Next** to complete installation.

- 7 Use the default printer name (for example, Dell Laser Printer 1700) or type a unique name for your printer, and then click **Next**.
- 8 Click **Yes (recommended)**, and then click **Finish** to print a test page.
- 9 After the test page prints, click **Yes** to close the window.
- 10 Click **Finish** to complete the installation and close the wizard.
- 11 The *Drivers and Utilities* CD should launch the installation software automatically.
If the CD does not automatically launch, click **Start**→**Run**, type **D:\setup.exe** (where D is the drive letter of your CD), and then click **OK**.
- 12 When the *Drivers and Utilities* CD screen appears, click **Personal Installation - Install the printer for use on this computer only** to install the additional software for your printer.
- 13 Select your printer from the drop-down box.
- 14 Select **Typical Installation (recommended)**, and then click **Install**.
When all of the files are installed on your computer, the Congratulations screen appears.
- 15 Click **Finish** to exit the *Drivers and Utilities* CD screen.

Using Windows 98 SE With a USB or Parallel Cable

 **NOTE:** Depending on the software and printers already installed on your computer, your screens may vary from those in the instructions.

If you are connecting the printer using a USB cable, you must install both a USB port driver and a custom print driver.

When you attached the cable and turned on the printer, the **Found New Hardware Wizard** appeared on your computer screen.

- 1 Insert the *Drivers and Utilities* CD, and then click **Next**.
- 2 Select **Search for a suitable driver**, and then click **Next**.
- 3 If you are using a USB cable, select **CD-ROM drive only**, and then click **Next**.
If you are using a parallel cable, skip to step 8.
- 4 After the wizard finds the USB port driver, click **Next**.
- 5 When the USB port driver is installed, click **Finish**.

The wizard prompts you to search for new drivers.

- 6 Click **Next** to search for a printer driver.
- 7 Select **Search for a suitable driver**, and then click **Next**.
- 8 Select **Specify a location only**, and then click **Next**.
- 9 Browse to the location of the printer driver on the *Drivers and Utilities* CD.
D:\Drivers\Print\Win_9xme\<your language folder>\dkaag2da.inf
- 10 Highlight the driver, and then select **to install the updated driver (recommended)**.
- 11 Click **Next**.
- 12 Click **Next** to complete installation.
- 13 Use the default printer name (for example, Dell Laser Printer 1700) or type a unique name for your printer, and then click **Next**.
- 14 Select **Yes** to print a test page, and then click **Finish**.
All the necessary files are installed on your computer.
- 15 After the test page prints, click **Yes** to close the message window.
- 16 Click **Finish** to complete the installation.
- 17 The *Drivers and Utilities* CD should launch the installation software automatically.
If the CD does not automatically launch, click **Start** → **Run**, type **D:\setup.exe** (where D is the drive letter of your CD), and then click **OK**.
- 18 When the *Drivers and Utilities* CD screen appears, click **Personal Installation - Install the printer for use on this computer only** to install the additional software for your printer.
- 19 Select your printer from the drop-down box.
- 20 Select **Typical Installation (recommended)**, and then click **Install**.
When all of the files are installed on your computer, the Congratulations screen appears.
- 21 Click **Finish** to exit the *Drivers and Utilities* CD screen.

SECTION 4

Setting Up for Network Printing

Network Set-Up

Network Set-Up

 **NOTE:** For additional network set-up configurations, refer to your *User's Guide*.

Attach Cables

- 1 Make sure the printer is turned off and unplugged.
- 2 Plug one end of a standard category 5 Unshielded Twisted Pair (UTP) network cable into a LAN drop or hub, and the other end into the Ethernet port (the middle connector) on the back of the printer. The printer automatically adjusts for the network speed.

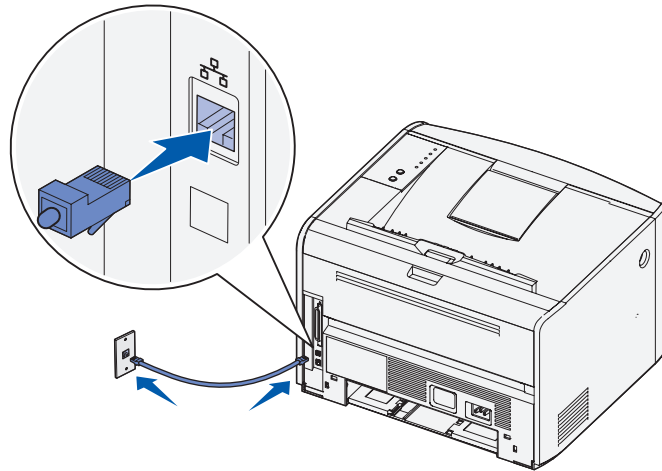

- 3 Plug one end of the printer power cord into the socket at the back of the printer and the other end into a properly grounded outlet.

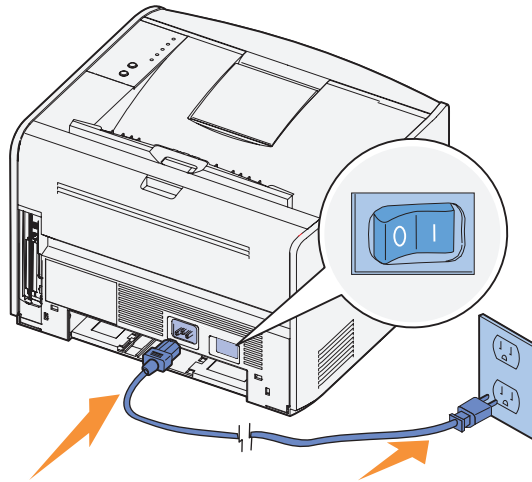

- 4 Turn on the printer.

After the printer completes its internal tests, the **Ready/Data** light comes on.

If the operator panel lights do not come on when the printer is turned on, make sure the power cord is firmly plugged in at the back of the printer and at the electrical outlet.

If the printer is on but nothing prints, or if print jobs are not printing and the **Error** light is on solid, make sure the toner cartridge is installed.

Print and Check the Network Setup Page

- 1 When the **Ready/Data** light is on solid, press and release **Continue** to print a menu settings page and a network setup page.
- 2 Under the Standard Network Card heading on the network setup page, make sure Status is Connected.
If Status is Not Connected:
 - Make sure the Ethernet cable is firmly plugged into the back of the printer.
 - Plug the Ethernet cable into another wall outlet.
- 3 Under the “TCP/IP” heading on the network setup page, make sure the IP address, netmask, and gateway are what you expected.

If you need to change the IP address, run the Set IP Address Utility from the Drivers and Utilities CD.

Run the Installation Software

- 1 Insert the *Drivers and Utilities* CD into your computer.
- 2 The *Drivers and Utilities* CD should launch the installation software automatically.
If the CD does not automatically launch, click **Start**→**Run**, type **D:\setup.exe** (where D is the drive letter of your CD), and then click **OK**.
- 3 When the *Drivers and Utilities* CD screen appears, click **Network Installation - Install the printer for use on a network**.
- 4 For local installation, select **Install printer on this computer**, and then click **Next**.
For remote installation:
 - a Select **Install printer on one or more remote computers**, and then click **Next**.
 - b Enter your Administrator user name and password, and then click **Add**.
 - c Select the clients or servers, and then click **Next**.
- 5 Select the network printer you would like to install. If you do not see your printer listed, click **Update** to refresh the list or click **Add Printer** to add a printer to the network.
If you are setting up a print server, proceed to step 6. A print server is a computer that manages all client print jobs on a network.
If you are setting up a client, skip to step 7. A client is one computer that is directly attached to the printer.
- 6 Select **I am setting up this printer on a server**, and then click **Next**.
- 7 Select your printer from the list. If you would like to change the printer name listed, enter a new name in the Printer Name field.
- 8 If you want other users on the network to access this printer, select **Share this printer with other computers**, and then enter a share name that users will easily identify.
- 9 Click **Next**.
- 10 Select the software and documentation you want to install, and then click **Install**. For more information, see "Software Overview" on page 43.
- 11 When the Congratulations! screen appears, select whether or not to restart your computer, and then click **Finish**.

Use the Dell Printer Configuration Web Tool, also known as the Printer Embedded Web Server, to monitor the status of your network printer without leaving your desk. You can view and/or change the printer configuration settings, monitor toner level, and when it is time to order replacement toner cartridges, just click the Dell supplies link right from your Web browser.

 **NOTE:** The Dell Printer Configuration Web Tool is not available when the printer is locally attached to a print server.

To launch the Dell Printer Configuration Web Tool, type the network printer IP address in your Web browser, and the printer configuration appears on the screen. Refer to your *User's Guide* for more information.

You can set up the Dell Printer Configuration Web Tool to send you an email when the printer needs supplies or intervention.

To set up email alerts:

- 1 Launch the Dell Printer Configuration Web Tool.
- 2 Click **Email Alert Setup**.
- 3 Under **Setup Email Server**, enter the Primary SMTP Gateway and the Reply Address.
- 4 Under **Setup Email Lists and Alerts**, enter your email address or the key operator's email address in the email list box.
- 5 Click **Submit**.

SECTION 5

Software Overview

Dell™ Toner Management System

Dell Local Printer Settings Utility

Set IP Address Utility

Dell Printer Software Uninstall

Driver Profiler

Dell Printer Configuration Web Tool

Use the *Drivers and Utilities* CD that came with your printer to install a combination of software applications, depending on your operating system.

 **NOTE:** If you purchased your printer and computer separately, you must use the *Drivers and Utilities* CD to install these software applications.

Dell™ Toner Management System

Status Monitor Center

 **NOTE:** This application is not available with Windows 98 SE or Me, or when the printer is connected locally to a computer.

Use the Status Monitor Center to manage multiple Status Monitors.

- Double-click a printer name to open its Status Monitor, or select **Run** to open a Status Monitor for a particular printer.
- Select **View** to change the appearance of the list of printers.
- Select **Help** to read the online Help.

Printing Status Window

 **NOTE:** This application is not available with Windows NT, 98 SE, or Me, or when the printer is connected to a network.

The Printing Status window displays the status of the printer (Printer Ready, Printer Offline, and Error-Check Printer) and the name of the job when you send a job to print.

The Printing Status window also displays the level of toner so you can:

- Monitor the toner level for your printer.
- Click **Order Toner** to order replacement toner cartridges.
See "Printer Supplies Reorder Application" on page 45 for more information.

Printer Supplies Reorder Application

 **NOTE:** This application is not available with Windows 98 SE or Me.

The Order Supplies dialog box can be launched from the Printing Status window, the Programs window, or the desktop icon.

You can order toner by phone or from the Web.

- 1 Click **Start**→**Programs** or **All Programs**→**Dell Printers**→**Dell Laser Printer 1700**→**Printer Supplies Reorder Application**. The Order Supplies window appears.
- 2 If ordering from the Web, click **Visit Dell's cartridge ordering web site**.
- 3 If ordering by phone, call the number that appears under the **By Telephone** heading.

Dell Local Printer Settings Utility

 This application is not available when the printer is connected to a network.

Use the Dell Local Printer Settings Utility to change and save printer settings not available from the printer driver. When you change these settings, they remain in effect until you make another selection and apply it, or until you restore the original printer settings (called factory default settings). The settings are organized by menu, much like a printer operator panel.

The Dell Local Printer Settings Utility is installed automatically on your computer when you install the Dell printer driver. Click **Start**→**Programs** or **All Programs**→**Dell Printers**→**Dell Laser Printer 1700**→**Dell Local Printer Settings Utility**. The Dell Local Printer Settings Utility only functions with printers connected directly to the computer.

Set IP Address Utility

 **NOTE:** This application is not available when the printer is connected locally to a computer.

The Set IP Address Utility lets you set up an IP address and other important IP parameters.

Dell Printer Software Uninstall

Use the Uninstall Software Utility to remove any currently installed printer software or printer objects. You can access the Uninstall Software Utility two ways:

- 1** For Windows XP only: Click **Start**→**Control Panel**→**Printers and Other Hardware**→**Printers and Faxes**.
For all others: Click **Start**→**Settings**→**Printers**.
 - a** Select the printer object to uninstall, and then right-click the mouse.
 - b** Select **Dell Software Uninstall**.
 - c** Select the components to uninstall, and then click **Next**.
 - d** Click **Uninstall Now**.
 - e** Click **OK** when the uninstall is complete.
- 2** Click **Start**→**Programs** or **All Programs**→**Dell Printers**→**Dell Laser Printer 1700**.
 - a** Select **Dell Printer Software Uninstall**.
 - b** Select the components to uninstall, and then click **Next**.
 - c** Click **Uninstall Now**.
 - d** Click **OK** when the uninstall is complete.

Driver Profiler

Use the Driver Profiler to create driver profiles that contain custom driver settings. A driver profile can contain a group of saved printer driver settings and other data for things such as:

- Print orientation and N-Up (document settings)
- Installation status of an output tray (printer options)
- User-defined paper sizes (custom papers)
- Simple text and watermarks
- Overlay references
- Font references
- Form associations

Dell Printer Configuration Web Tool

 **NOTE:** This application is not available when the printer is connected locally to a computer.

The Dell Printer Configuration Web Tool, also known as the Printer Embedded Web Server, lets you monitor the status of your network printer without leaving your desk. You can view and/or change the printer configuration settings, monitor toner level, and when it is time to order replacement toner cartridges, just click the Dell supplies link right from your Web browser.

To launch the Dell Printer Configuration Web Tool, type the network printer IP address in your Web browser, and the printer configuration appears on the screen. Refer to your *User's Guide* for more information.

You can set up the Dell Printer Configuration Web Tool to send you an email when the printer needs supplies or intervention.

To set up email alerts:

- 1 Launch the Dell Printer Configuration Web Tool.
- 2 Click **Email Alert Setup**.
- 3 Under **Setup Email Server**, enter the Primary SMTP Gateway and the Reply Address.
- 4 Under **Setup Email Lists and Alerts**, enter your email address or the key operator's email address in the email list box.
- 5 Click **Submit**.

SECTION 6

Troubleshooting

Basic Problems

Replacing the Toner Cartridge

Replacing the Imaging Drum

Clearing Paper Jams

Basic Problems

Use the following tables to find solutions for printing problems you encounter. If you cannot fix the problem, contact Dell at support.dell.com. You may have a printer part that requires cleaning or replacement by a service technician.

Problem	What to do
The print is getting light, but the Toner Low/Replace Drum light is not on.	<ul style="list-style-type: none"> Remove the toner cartridge and gently shake it from side to side to use the remaining toner. Replace the toner cartridge. See “Replacing the Toner Cartridge” on page 54 for more information.

The **Toner Low/Replace Drum** light is on (not blinking).

NOTE: If the light is blinking, see "The Toner Low/Replace Drum light is blinking." on page 51.

- Remove the toner cartridge and gently shake it to use the remaining toner.
- Replace the toner cartridge. See “Replacing the Toner Cartridge” on page 54 for more information.

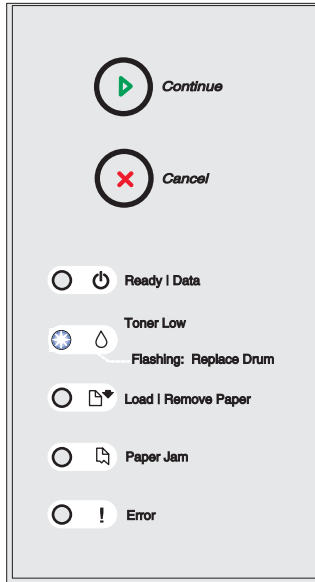

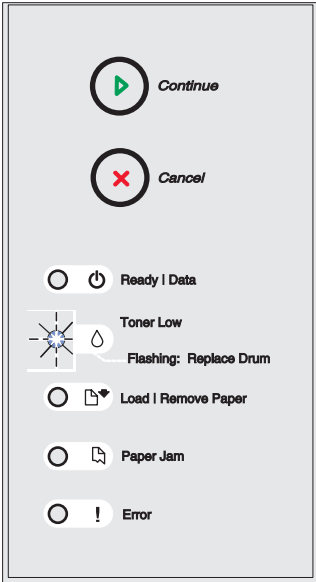
Problem	What to do
<p>The Toner Low/Replace Drum light is blinking.</p>	<p>Replace the Imaging Drum. See “Replacing the Imaging Drum” on page 57 for more information.</p>
 <p>The image shows a printer's control panel with several buttons and indicators. At the top are two large circular buttons: a green play button labeled 'Continue' and a red 'X' button labeled 'Cancel'. Below these are six smaller circular indicators, each with an icon and a label: a power icon for 'Ready Data', a blue starburst icon for 'Toner Low', a red starburst icon for 'Flashing: Replace Drum', a paper icon for 'Load Remove Paper', a paper jam icon for 'Paper Jam', and an exclamation mark icon for 'Error'.</p>	
<p>Pages are blank.</p>	<ul style="list-style-type: none"> • The toner cartridge may be out of toner. Replace the cartridge. See “Replacing the Toner Cartridge” on page 54 for more information. • You may have a software error. Try turning the printer off and back on.
<p>The printer has missing or damaged parts.</p>	<p>Contact Dell at support.dell.com.</p>
<p>The operator panel lights do not come on when the printer is turned on.</p>	<ul style="list-style-type: none"> • Wait to see if the lights come on. This may take a few seconds. • Make sure the power cord is firmly plugged in at the back of the printer and at the electrical outlet.
<p>You cannot close the front cover.</p>	<p>Make sure the toner cartridge is positioned correctly.</p>

Problem	What to do
The printer is on, but nothing prints.	<ul style="list-style-type: none"> • Make sure the toner cartridge is installed. • Make sure the parallel, USB, or network cable is firmly plugged into the connector on the back of the printer. • Press and release Continue to print a menu settings page to determine if the problem is with the printer or the computer. • If you can print a menu settings page, the problem is in the computer or the software program. • If you cannot print a menu settings page, contact Dell at support.dell.com.
The printer is on and the Error light is on.	Make sure the printer cover is closed.

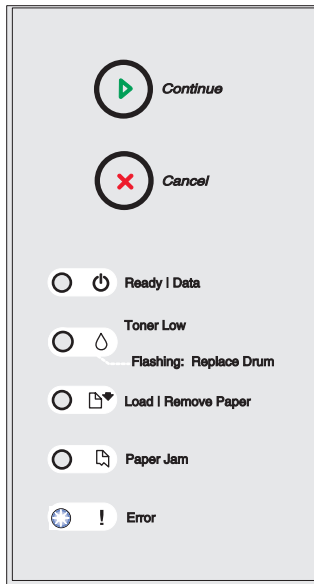

Problem**What to do**

The **Load Paper** light is on, even though there is paper loaded in the 250-sheet or 550-sheet tray.

Make sure the tray is pushed all the way in.

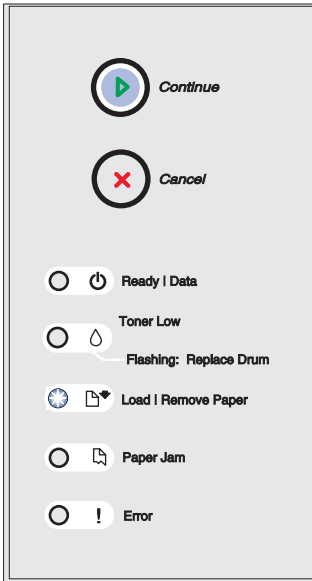

Paper is jammed in the printer.

See “Clearing Paper Jams” on page 60 for more information.

For information on solving print quality problems, refer to your *User’s Guide*.

Replacing the Toner Cartridge

⚠ CAUTION: When replacing a toner cartridge, do not leave the new cartridge exposed to direct light for an extended period of time. Extended light exposure can cause print quality problems.

- 1 Open the front cover by pressing the button on the left side of the printer and lowering the cover.

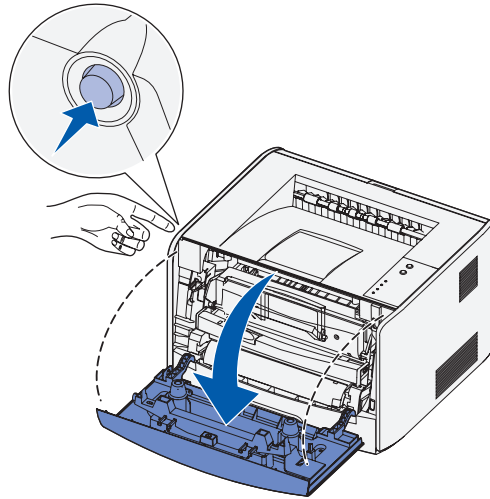

- 2 Remove the toner cartridge:
 - a Press the button on the base of the toner cartridge assembly.

- b** Pull the toner cartridge up and out using the handle.

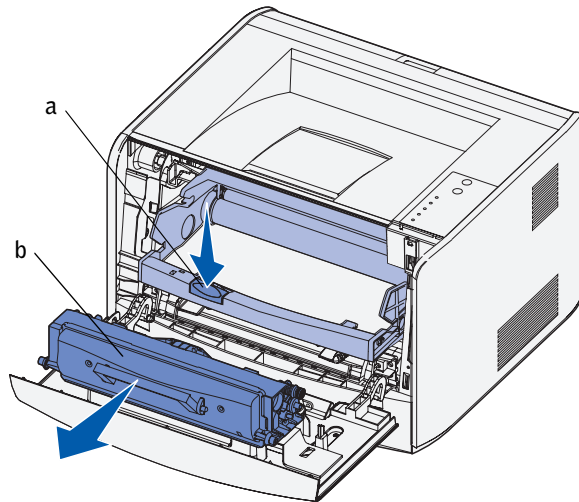

- 3** Unpack the new toner cartridge.
- 4** Rotate the cartridge in all directions to distribute the toner.

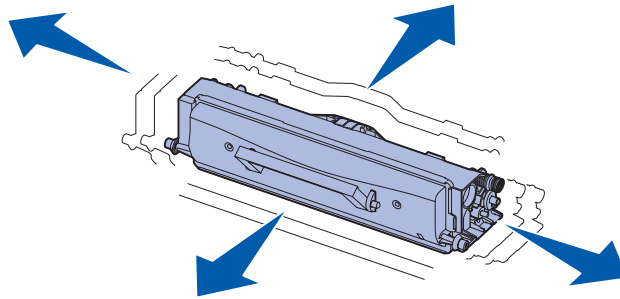

- 5 Install the new toner cartridge by aligning the white rollers on the toner cartridge with the white arrows on the tracks of the imaging drum and pushing the toner cartridge in as far as it will go. The cartridge *clicks* into place when correctly installed.

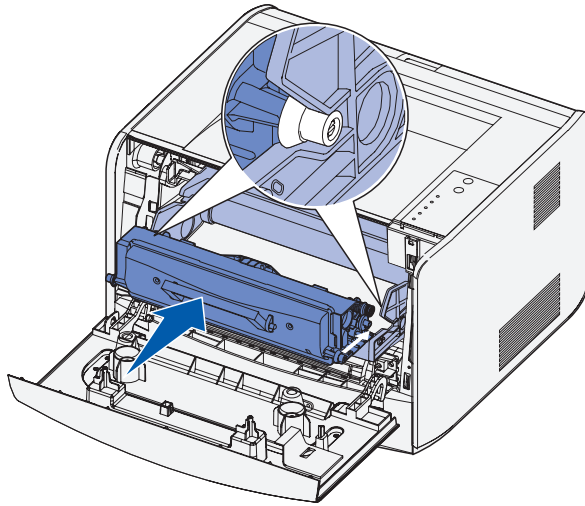

- 6 Close the front cover.

Replacing the Imaging Drum

NOTICE: When replacing an imaging drum, do not leave the toner cartridge or the new imaging drum exposed to direct light for an extended period of time. Extended light exposure can cause print quality problems.

- 1 Open the front cover by pressing the button on the left side of the printer and lowering the cover.

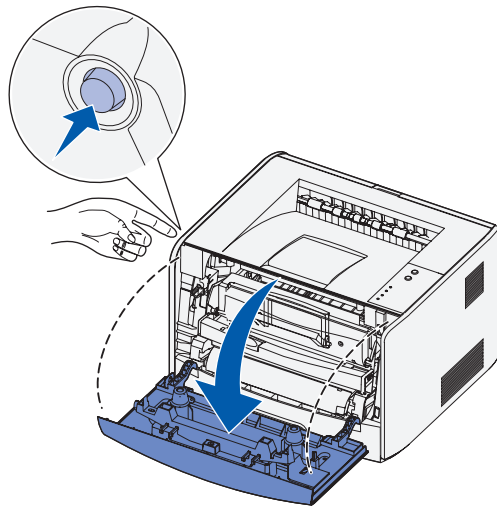

- 2 Pull the toner cartridge assembly out of the printer by pulling on the toner cartridge handle.

 **NOTE:** Do not press the button on the toner cartridge assembly.

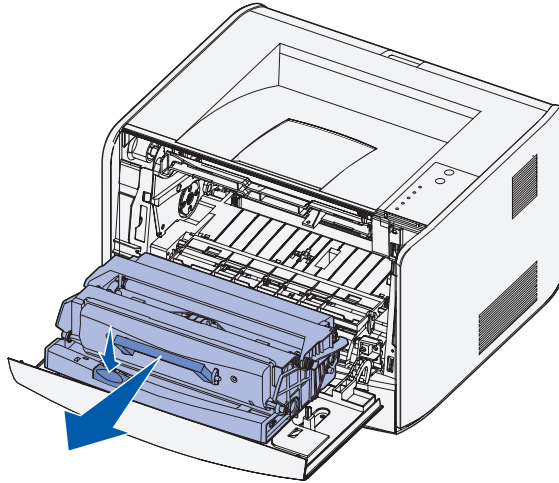

Place the toner cartridge assembly on a flat, clean surface.

- 3** Remove the toner cartridge:
 - a** Press the button on the base of the toner cartridge assembly.
 - b** Pull the toner cartridge up and out using the handle.

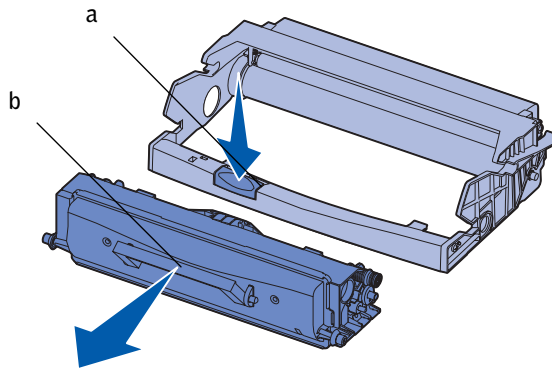

- 4** Unpack the new imaging drum.

- 5 Install the toner cartridge into the new toner cartridge assembly by aligning the white rollers on the toner cartridge with the white arrows on the tracks of the imaging drum and pushing the toner cartridge in as far as it will go. The cartridge *clicks* into place when correctly installed.

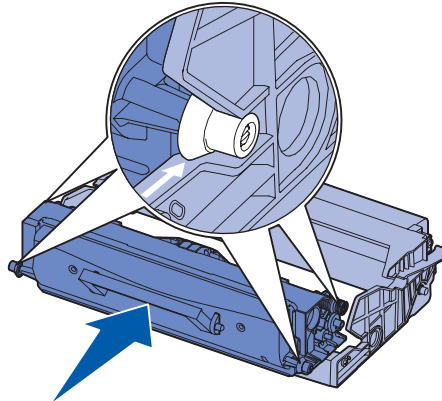

- 6 Install the toner cartridge assembly into the printer by aligning the green arrows on the guides of the toner cartridge assembly with the green arrows on the tracks in the printer and pushing the toner cartridge assembly in as far as it will go.

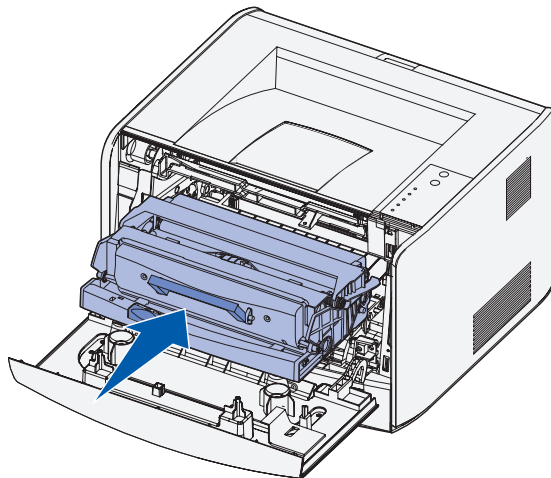

7 After you replace the imaging drum, you should reset the imaging drum's counter. To reset the counter, press and hold the **Cancel** button until all lights flash in sequence.

➡ **NOTICE:** Resetting the imaging drum's counter without replacing the imaging drum may damage your printer and void your warranty.

8 Close the front cover.

Clearing Paper Jams

When a paper jam occurs, the printer stops and the operator panel's **Paper Jam** and **Continue** lights come on. Press and release **Continue** twice quickly to display the specific secondary error paper jam light sequence. Refer to your *User's Guide* for more information.

We recommend that you clear the entire paper path when a paper jam occurs.

To clear a paper jam:

1 If you are feeding paper from a tray, remove the tray, and then remove any jams.

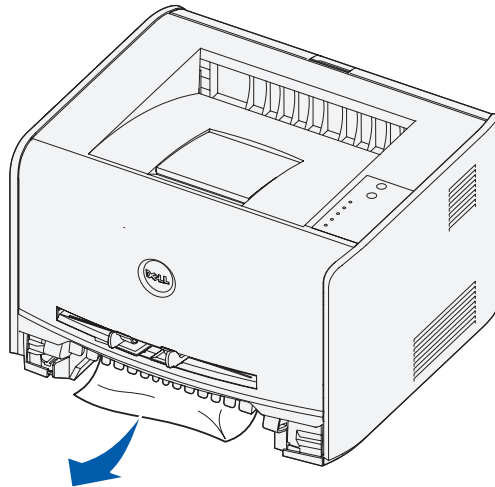

- 2 Open the front cover and remove the toner cartridge assembly.

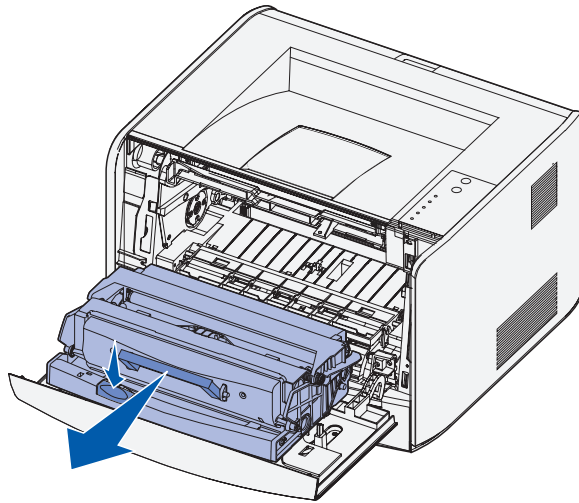

➔ NOTICE: Do not leave the toner cartridge assembly exposed to direct light for an extended period of time. Extended light exposure can cause print quality problems.

- 3 Remove any jams in the area behind the toner cartridge assembly.

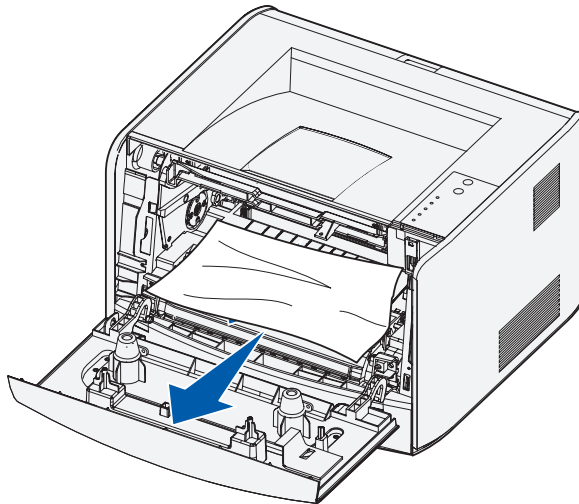

- 4 Lift the flap at the front of the printer and remove any jams beneath the flap.

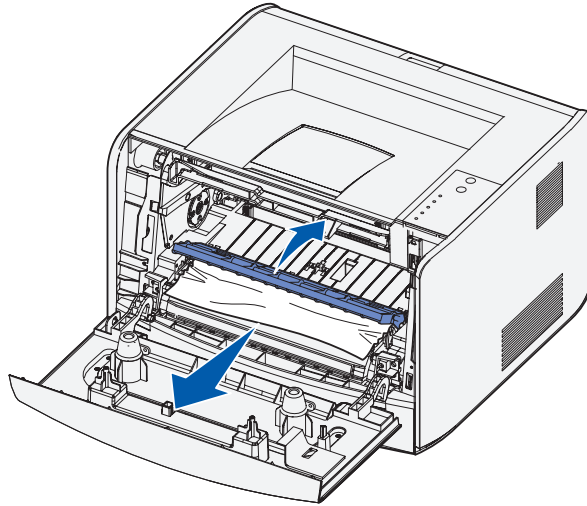

- 5 Open the rear exit and remove any jams.

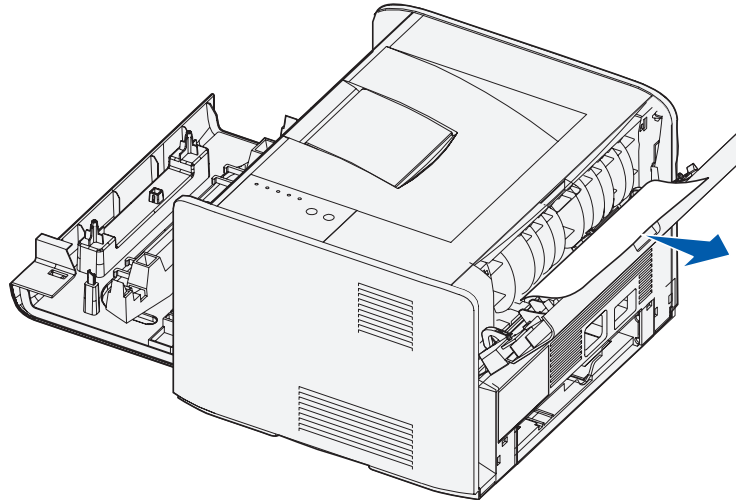

- 6 After you have cleared the jams, reinstall the toner cartridge assembly, make sure all printer covers and trays are closed, and then press **Continue** to resume printing.

 **NOTE:** The printer reprints the pages that caused the paper jam.

SECTION 7

Contacting Dell

Technical Assistance

Automated Order-Status Service

Contacting Dell

Technical Assistance

If you need help with a technical problem, Dell is ready to assist you.

- 1 Call technical support from a telephone near or at the printer so that technical support can assist you with any necessary procedures. When calling Dell, use your Express Service Code to help expedite the routing of your call to the proper support personnel.

The Express Service Code is located under the front cover of your printer.

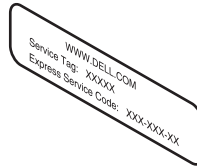

NOTE: Dell's Express Service Code system may not be available in all countries.

- 2 In the U.S., Business customers should call 1-877-459-7298, and Consumer (Home and Home Office) customers should call 1-800-624-9896.

If you are calling from a different country or are in a different Service area, see "Contacting Dell" on page 65 for your local telephone number.

- 3 Follow the menu prompts in the automated telephone system to speak with a technical support representative.

Automated Order-Status Service

To check on the status of any Dell products that you have ordered, you can go to support.dell.com, or you can call the automated order-status service. A recording prompts you for the information needed to locate and report on your order. See "Contacting Dell" on page 65 for the telephone number to call for your region.

Contacting Dell

To contact Dell electronically, you can access the following websites:

- www.dell.com
- support.dell.com (technical support)
- premiersupport.dell.com (technical support for educational, government, healthcare, and medium/large business customers, including Premier, Platinum, and Gold customers)

For specific web addresses for your country, find the appropriate country section in the table below.

NOTE: Toll-free numbers are for use within the country for which they are listed.

When you need to contact Dell, use the electronic addresses, telephone numbers, and codes provided in the following table. If you need assistance in determining which codes to use, contact a local or an international operator.

Country (City) International Access Code Country Code City Code	Department Name or Service Area, Website and E-Mail Address	Area Codes, Local Numbers, and Toll-Free Numbers
U.S.A. (Austin, Texas)	Automated Order-Status Service	toll-free: 1-800-433-9014
International Access Code: 011	AutoTech (portable and desktop computers)	toll-free: 1-800-247-9362
Country Code: 1	Consumer (Home and Home Office)	
	Technical Support	toll-free: 1-800-624-9896
	Customer Service	toll-free: 1-800-624-9897
	DellNet™ Service and Support	toll-free: 1-877-Dellnet (1-877-335-5638)
	Employee Purchase Program (EPP) Customers	toll-free: 1-800-695-8133
	Financial Services website: www.dellfinancialservices.com	
	Financial Services (lease/loans)	toll-free: 1-877-577-3355
	Financial Services (Dell Preferred Accounts [DPA])	toll-free: 1-800-283-2210
	Business	
	Customer Service and Technical Support	toll-free: 1-877-459-7298
	Employee Purchase Program (EPP) Customers	toll-free: 1-800-695-8133
	Projectors Technical Support	toll-free: 1-877-459-7298
	Public (government, education, and healthcare)	
	Customer Service and Technical Support	toll-free: 1-800-456-3355
	Employee Purchase Program (EPP) Customers	toll-free: 1-800-234-1490
	Dell Sales	toll-free: 1-800-289-3355 or toll-free: 1-800-879-3355
	Dell Outlet Store (Dell refurbished computers)	toll-free: 1-888-798-7561
	Software and Peripherals Sales	toll-free: 1-800-671-3355
	Spare Parts Sales	toll-free: 1-800-357-3355
	Extended Service and Warranty Sales	toll-free: 1-800-247-4618
	Fax	toll-free: 1-800-727-8320
	Dell Services for the Deaf, Hard-of-Hearing, or Speech-Impaired	toll-free: 1-877-DELLTY (1-877-335-5889)
Anguilla	General Support	toll-free: 800-335-0031
Antigua and Barbuda	General Support	1-800-805-5924

Country (City) International Access Code Country Code City Code	Department Name or Service Area, Website and E-Mail Address	Area Codes, Local Numbers, and Toll-Free Numbers
Argentina (Buenos Aires)	Website: www.dell.com.ar	
International Access Code: 00	Tech Support and Customer Care	toll-free: 0-800-444-0733
Country Code: 54	Sales	0-810-444-3355
City Code: 11	Tech Support Fax	11 4515 7139
	Customer Care Fax	11 4515 7138
Aruba	General Support	toll-free: 800-1578
Australia (Sydney)	E-mail (Australia): au_tech_support@dell.com	
International Access Code: 0011	E-mail (New Zealand): nz_tech_support@dell.com	
Country Code: 61	Home and Small Business	1-300-65-55-33
City Code: 2	Government and Business	toll-free: 1-800-633-559
	Preferred Accounts Division (PAD)	toll-free: 1-800-060-889
	Customer Care	toll-free: 1-800-819-339
	Corporate Sales	toll-free: 1-800-808-385
	Transaction Sales	toll-free: 1-800-808-312
	Fax	toll-free: 1-800-818-341
Austria (Vienna)	Website: support.euro.dell.com	
International Access Code: 900	E-mail: tech_support_central_europe@dell.com	
Country Code: 43	Home/Small Business Sales	0820 240 530 00
City Code: 1	Home/Small Business Fax	0820 240 530 49
	Home/Small Business Customer Care	0820 240 530 14
	Preferred Accounts/Corporate Customer Care	0820 240 530 16
	Home/Small Business Technical Support	0820 240 530 14
	Preferred Accounts/Corporate Technical Support	0660 8779
	Switchboard	0820 240 530 00
Bahamas	General Support	toll-free: 1-866-278-6818
Barbados	General Support	1-800-534-3066

Country (City) International Access Code Country Code City Code	Department Name or Service Area, Website and E-Mail Address	Area Codes, Local Numbers, and Toll-Free Numbers
Belgium (Brussels) International Access Code: 00 Country Code: 32 City Code: 2	Website: support.euro.dell.com E-mail: tech_be@dell.com E-mail for French Speaking Customers: support.euro.dell.com/be/fr/emaildell/ Technical Support Customer Care Corporate Sales Fax Switchboard	 02 481 92 88 02 481 91 19 02 481 91 00 02 481 92 99 02 481 91 00
Bermuda	General Support	1-800-342-0671
Bolivia	General Support	toll-free: 800-10-0238
Brazil International Access Code: 00 Country Code: 55 City Code: 51	Website: www.dell.com/br Customer Support, Technical Support Tech Support Fax Customer Care Fax Sales	 0800 90 3355 51 481 5470 51 481 5480 0800 90 3390
British Virgin Islands	General Support	toll-free: 1-866-278-6820
Brunei Country Code: 673	Customer Technical Support (Penang, Malaysia) Customer Service (Penang, Malaysia) Transaction Sales (Penang, Malaysia)	 604 633 4966 604 633 4949 604 633 4955
Canada (North York, Ontario) International Access Code: 011	Online Order Status: www.dell.ca/ostatus AutoTech (automated technical support) TechFax Customer Care (Home Sales/Small Business) Customer Care (med./large business, government) Technical Support (Home Sales/Small Business) Technical Support (med./large bus., government) Sales (Home Sales/Small Business) Sales (med./large bus., government) Spare Parts Sales & Extended Service Sales	 toll-free: 1-800-247-9362 toll-free: 1-800-950-1329 toll-free: 1-800-847-4096 toll-free: 1-800-326-9463 toll-free: 1-800-847-4096 toll-free: 1-800-387-5757 toll-free: 1-800-387-5752 toll-free: 1-800-387-5755 1 866 440 3355

Country (City) International Access Code Country Code City Code	Department Name or Service Area, Website and E-Mail Address	Area Codes, Local Numbers, and Toll-Free Numbers
Cayman Islands	General Support	1-800-805-7541
Chile (Santiago) Country Code: 56 City Code: 2	Sales, Customer Support, and Technical Support	toll-free: 1230-020-4823
China (Xiamen) Country Code: 86 City Code: 592	Tech Support website: support.ap.dell.com/china Tech Support E-mail: cn_support@dell.com Tech Support Fax	818 1350
	Home and Small Business Technical Support	toll-free: 800 858 2437
	Corporate Accounts Technical Support	toll-free: 800 858 2333
	Customer Experience	toll-free: 800 858 2060
	Home and Small Business	toll-free: 800 858 2222
	Preferred Accounts Division	toll-free: 800 858 2557
	Large Corporate Accounts GCP	toll-free: 800 858 2055
	Large Corporate Accounts Key Accounts	toll-free: 800 858 2628
	Large Corporate Accounts North	toll-free: 800 858 2999
	Large Corporate Accounts North Government and Education	toll-free: 800 858 2955
	Large Corporate Accounts East	toll-free: 800 858 2020
	Large Corporate Accounts East Government and Education	toll-free: 800 858 2669
	Large Corporate Accounts Queue Team	toll-free: 800 858 2222
	Large Corporate Accounts South	toll-free: 800 858 2355
	Large Corporate Accounts West	toll-free: 800 858 2811
	Large Corporate Accounts Spare Parts	toll-free: 800 858 2621
Colombia	General Support	980-9-15-3978
Costa Rica	General Support	0800-012-0435

Country (City) International Access Code Country Code City Code	Department Name or Service Area, Website and E-Mail Address	Area Codes, Local Numbers, and Toll-Free Numbers
Czech Republic (Prague)	Website: support.euro.dell.com	
International Access Code: 00	E-mail: czech_dell@dell.com	
Country Code: 420	Technical Support	02 2186 27 27
City Code: 2	Customer Care	02 2186 27 11
	Fax	02 2186 27 14
	TechFax	02 2186 27 28
	Switchboard	02 2186 27 11
Denmark (Copenhagen)	Website: support.euro.dell.com	
International Access Code: 00	E-mail Support (portable computers): den_nbk_support@dell.com	
Country Code: 45	E-mail Support (desktop computers): den_support@dell.com	
	E-mail Support (servers): Nordic_server_support@dell.com	
	Technical Support	7023 0182
	Customer Care (Relational)	7023 0184
	Home/Small Business Customer Care	3287 5505
	Switchboard (Relational)	3287 1200
	Fax Switchboard (Relational)	3287 1201
	Switchboard (Home/Small Business)	3287 5000
	Fax Switchboard (Home/Small Business)	3287 5001
Dominica	General Support	toll-free: 1-866-278-6821
Dominican Republic	General Support	1-800-148-0530
Ecuador	General Support	toll-free: 999-119
El Salvador	General Support	01-899-753-0777

Country (City) International Access Code Country Code City Code	Department Name or Service Area, Website and E-Mail Address	Area Codes, Local Numbers, and Toll-Free Numbers
Finland (Helsinki) International Access Code: 990 Country Code: 358 City Code: 9	Website: support.euro.dell.com E-mail: fin_support@dell.com E-mail Support (servers): Nordic_support@dell.com	
	Technical Support	09 253 313 60
	Technical Support Fax	09 253 313 81
	Relational Customer Care	09 253 313 38
	Home/Small Business Customer Care	09 693 791 94
	Fax	09 253 313 99
	Switchboard	09 253 313 00
France (Paris) (Montpellier) International Access Code: 00 Country Code: 33 City Codes: (1) (4)	Website: support.euro.dell.com E-mail: support.euro.dell.com/fr/fr/emaildell/ Home and Small Business	
	Technical Support	0825 387 270
	Customer Care	0825 823 833
	Switchboard	0825 004 700
	Switchboard (calls from outside of France)	04 99 75 40 00
	Sales	0825 004 700
	Fax	0825 004 701
	Fax (calls from outside of France)	04 99 75 40 01
	Corporate	
	Technical Support	0825 004 719
	Customer Care	0825 338 339
	Switchboard	01 55 94 71 00
	Sales	01 55 94 71 00
	Fax	01 55 94 71 01

Country (City) International Access Code Country Code City Code	Department Name or Service Area, Website and E-Mail Address	Area Codes, Local Numbers, and Toll-Free Numbers
Germany (Langen)	Website: support.euro.dell.com	
International Access Code: 00	E-mail: tech_support_central_europe@dell.com	
Country Code: 49	Technical Support	06103 766-7200
City Code: 6103	Home/Small Business Customer Care	0180-5-224400
	Global Segment Customer Care	06103 766-9570
	Preferred Accounts Customer Care	06103 766-9420
	Large Accounts Customer Care	06103 766-9560
	Public Accounts Customer Care	06103 766-9555
	Switchboard	06103 766-7000
Greece	Website: support.euro.dell.com	
International Access Code: 00	E-mail: support.euro.dell.com/gr/en/emailldell/	
Country Code: 30	Technical Support	080044149518
	Gold Technical Support	08844140083
	Switchboard	2108129800
	Sales	2108129800
	Fax	2108129812
Grenada	General Support	toll-free: 1-866-540-3355
Guatemala	General Support	1-800-999-0136
Guyana	General Support	toll-free: 1-877-270-4609

Country (City) International Access Code Country Code City Code	Department Name or Service Area, Website and E-Mail Address	Area Codes, Local Numbers, and Toll-Free Numbers
Hong Kong	Website: support.ap.dell.com	
International Access Code: 001	E-mail: ap_support@dell.com	
Country Code: 852	Technical Support (Dimension™ and Inspiron™)	2969 3189
	Technical Support (OptiPlex™, Latitude™, and Dell Precision™)	2969 3191
	Technical Support (PowerApp™ and PowerVault™)	2969 3196
	Gold Queue EEC Hotline	2969 3187
	Customer Advocacy	3416 0910
	Large Corporate Accounts	3416 0907
	Global Customer Programs	3416 0908
	Medium Business Division	3416 0912
	Home and Small Business Division	2969 3105
India	Technical Support	1600 33 8045
	Sales	1600 33 8044
Ireland (Cherrywood)	Website: support.euro.dell.com	
International Access Code: 16	E-mail: dell_direct_support@dell.com	
Country Code: 353	Technical Support	1850 543 543
City Code: 1	U.K. Technical Support (dial within U.K. only)	0870 908 0800
	Home User Customer Care	01 204 4014
	Small Business Customer Care	01 204 4014
	U.K. Customer Care (dial within U.K. only)	0870 906 0010
	Corporate Customer Care	1850 200 982
	Corporate Customer Care (dial within U.K. only)	0870 907 4499
	Ireland Sales	01 204 4444
	U.K. Sales (dial within U.K. only)	0870 907 4000
	Fax/SalesFax	01 204 0103
	Switchboard	01 204 4444

Country (City) International Access Code Country Code City Code	Department Name or Service Area, Website and E-Mail Address	Area Codes, Local Numbers, and Toll-Free Numbers
Italy (Milan)	Website: support.euro.dell.com	
International Access Code: 00	E-mail: support.euro.dell.com/it/it/emaildell/	
Country Code: 39	Home and Small Business	
City Code: 02	Technical Support	02 577 826 90
	Customer Care	02 696 821 14
	Fax	02 696 821 13
	Switchboard	02 696 821 12
	Corporate	
	Technical Support	02 577 826 90
	Customer Care	02 577 825 55
	Fax	02 575 035 30
	Switchboard	02 577 821
Jamaica	General Support (dial from within Jamaica only)	1-800-682-3639

Country (City) International Access Code Country Code City Code	Department Name or Service Area, Website and E-Mail Address	Area Codes, Local Numbers, and Toll-Free Numbers
Japan (Kawasaki)	Website: support.jp.dell.com	
International Access Code: 001	Technical Support (servers)	toll-free: 0120-198-498
Country Code: 81	Technical Support outside of Japan (servers)	81-44-556-4162
City Code: 44	Technical Support (Dimension™ and Inspiron™)	toll-free: 0120-198-226
	Technical Support outside of Japan (Dimension and Inspiron)	81-44-520-1435
	Technical Support (Dell Precision™, OptiPlex™, and Latitude™)	toll-free:0120-198-433
	Technical Support outside of Japan (Dell Precision, OptiPlex, and Latitude)	81-44-556-3894
	Technical Support (Axim™)	toll-free: 0120-981-690
	Technical Support outside of Japan (Axim)	81-44-556-3468
	Faxbox Service	044-556-3490
	24-Hour Automated Order Service	044-556-3801
	Customer Care	044-556-4240
	Business Sales Division (up to 400 employees)	044-556-1465
	Preferred Accounts Division Sales (over 400 employees)	044-556-3433
	Large Corporate Accounts Sales (over 3500 employees)	044-556-3430
	Public Sales (government agencies, educational institutions, and medical institutions)	044-556-1469
	Global Segment Japan	044-556-3469
	Individual User	044-556-1760
	Switchboard	044-556-4300
Korea (Seoul)	Technical Support	toll-free: 080-200-3800
International Access Code: 001	Sales	toll-free: 080-200-3600
Country Code: 82	Customer Service (Seoul, Korea)	toll-free: 080-200-3800
City Code: 2	Customer Service (Penang, Malaysia)	604 633 4949
	Fax	2194-6202
	Switchboard	2194-6000

Country (City) International Access Code Country Code City Code	Department Name or Service Area, Website and E-Mail Address	Area Codes, Local Numbers, and Toll-Free Numbers
Latin America	Customer Technical Support (Austin, Texas, U.S.A.)	512 728-4093
	Customer Service (Austin, Texas, U.S.A.)	512 728-3619
	Fax (Technical Support and Customer Service) (Austin, Texas, U.S.A.)	512 728-3883
	Sales (Austin, Texas, U.S.A.)	512 728-4397
	SalesFax (Austin, Texas, U.S.A.)	512 728-4600 or 512 728-3772
Luxembourg	Website: support.euro.dell.com	
International Access Code: 00	E-mail: tech_be@dell.com	
Country Code: 352	Technical Support (Brussels, Belgium)	3420808075
	Home/Small Business Sales (Brussels, Belgium)	toll-free: 080016884
	Corporate Sales (Brussels, Belgium)	02 481 91 00
	Customer Care (Brussels, Belgium)	02 481 91 19
	Fax (Brussels, Belgium)	02 481 92 99
	Switchboard (Brussels, Belgium)	02 481 91 00
Macao	Technical Support	toll-free: 0800 582
Country Code: 853	Customer Service (Penang, Malaysia)	604 633 4949
	Transaction Sales	toll-free: 0800 581
Malaysia (Penang)	Technical Support	toll-free: 1 800 888 298
International Access Code: 00	Customer Service	04 633 4949
Country Code: 60	Transaction Sales	toll-free: 1 800 888 202
City Code: 4	Corporate Sales	toll-free: 1 800 888 213

Country (City) International Access Code Country Code City Code	Department Name or Service Area, Website and E-Mail Address	Area Codes, Local Numbers, and Toll-Free Numbers
Mexico International Access Code: 00 Country Code: 52	Customer Technical Support Sales Customer Service Main	001-877-384-8979 or 001-877-269-3383 50-81-8800 or 01-800-888-3355 001-877-384-8979 or 001-877-269-3383 50-81-8800 or 01-800-888-3355
Montserrat	General Support	toll-free: 1-866-278-6822
Netherlands Antilles	General Support	001-800-882-1519
Netherlands (Amsterdam) International Access Code: 00 Country Code: 31 City Code: 20	Website: support.euro.dell.com E-mail (Technical Support): (Enterprise): nl_server_support@dell.com (Latitude): nl_latitude_support@dell.com (Inspiron): nl_inspiron_support@dell.com (Dimension): nl_dimension_support@dell.com (OptiPlex): nl_optiplex_support@dell.com (Dell Precision): nl_workstation_support@dell.com	
	Technical Support	020 674 45 00
	Technical Support Fax	020 674 47 66
	Home/Small Business Customer Care	020 674 42 00
	Relational Customer Care	020 674 4325
	Home/Small Business Sales	020 674 55 00
	Relational Sales	020 674 50 00
	Home/Small Business Sales Fax	020 674 47 75
	Relational Sales Fax	020 674 47 50
	Switchboard	020 674 50 00
	Switchboard Fax	020 674 47 50

Country (City) International Access Code Country Code City Code	Department Name or Service Area, Website and E-Mail Address	Area Codes, Local Numbers, and Toll-Free Numbers
New Zealand	E-mail (New Zealand): nz_tech_support@dell.com	
International Access Code: 00	E-mail (Australia): au_tech_support@dell.com	
Country Code: 64	Home and Small Business	0800 446 255
	Government and Business	0800 444 617
	Sales	0800 441 567
	Fax	0800 441 566
Nicaragua	General Support	001-800-220-1006
Norway (Lysaker)	Website: support.euro.dell.com	
International Access Code: 00	E-mail Support (portable computers):	
Country Code: 47	nor_nbk_support@dell.com	
	E-mail Support (desktop computers):	
	nor_support@dell.com	
	E-mail Support (servers):	
	nordic_server_support@dell.com	
	Technical Support	671 16882
	Relational Customer Care	671 17514
	Home/Small Business Customer Care	23162298
	Switchboard	671 16800
	Fax Switchboard	671 16865
Panama	General Support	001-800-507-0962
Peru	General Support	0800-50-669
Poland (Warsaw)	Website: support.euro.dell.com	
International Access Code: 011	E-mail: pl_support_tech@dell.com	
Country Code: 48	Customer Service Phone	57 95 700
City Code: 22	Customer Care	57 95 999
	Sales	57 95 999
	Customer Service Fax	57 95 806
	Reception Desk Fax	57 95 998
	Switchboard	57 95 999

Country (City) International Access Code Country Code City Code	Department Name or Service Area, Website and E-Mail Address	Area Codes, Local Numbers, and Toll-Free Numbers
Portugal	Website: support.euro.dell.com	
International Access Code: 00	E-mail: support.euro.dell.com/pt/en/emaiddell/	
Country Code: 351	Technical Support	707200149
	Customer Care	800 300 413
	Sales	800 300 410 or 800 300 411 or 800 300 412 or 21 422 07 10
	Fax	21 424 01 12
Puerto Rico	General Support	1-800-805-7545
St. Kitts and Nevis	General Support	toll-free: 1-877-441-4731
St. Lucia	General Support	1-800-882-1521
St. Vincent and the Grenadines	General Support	toll-free: 1-877-270-4609
Singapore (Singapore)	Technical Support	toll-free: 800 6011 051
International Access Code: 005	Customer Service (Penang, Malaysia)	604 633 4949
Country Code: 65	Transaction Sales	toll-free: 800 6011 054
	Corporate Sales	toll-free: 800 6011 053
South Africa (Johannesburg)	Website: support.euro.dell.com	
International Access Code:	E-mail: dell_za_support@dell.com	
09/091	Technical Support	011 709 7710
Country Code: 27	Customer Care	011 709 7707
City Code: 11	Sales	011 709 7700
	Fax	011 706 0495
	Switchboard	011 709 7700
Southeast Asian and Pacific Countries	Customer Technical Support, Customer Service, and Sales (Penang, Malaysia)	604 633 4810

Country (City) International Access Code Country Code City Code	Department Name or Service Area, Website and E-Mail Address	Area Codes, Local Numbers, and Toll-Free Numbers
Spain (Madrid)	Website: support.euro.dell.com	
International Access Code: 00	E-mail: support.euro.dell.com/es/es/emaildell/	
Country Code: 34	Home and Small Business	
City Code: 91	Technical Support	902 100 130
	Customer Care	902 118 540
	Sales	902 118 541
	Switchboard	902 118 541
	Fax	902 118 539
	Corporate	
	Technical Support	902 100 130
	Customer Care	902 118 546
	Switchboard	91 722 92 00
	Fax	91 722 95 83
Sweden (Upplands Vasby)	Website: support.euro.dell.com	
International Access Code: 00	E-mail: swe_support@dell.com	
Country Code: 46	E-mail Support for Latitude and Inspiron: Swe-nbk_kats@dell.com	
City Code: 8	E-mail Support for OptiPlex: Swe_kats@dell.com	
	E-mail Support for Servers: Nordic_server_support@dell.com	
	Technical Support	08 590 05 199
	Relational Customer Care	08 590 05 642
	Home/Small Business Customer Care	08 587 70 527
	Employee Purchase Program (EPP) Support	20 140 14 44
	Fax Technical Support	08 590 05 594
	Sales	08 590 05 185

Country (City) International Access Code Country Code City Code	Department Name or Service Area, Website and E-Mail Address	Area Codes, Local Numbers, and Toll-Free Numbers
Switzerland (Geneva) International Access Code: 00 Country Code: 41 City Code: 22	Website: support.euro.dell.com E-mail: swisstech@dell.com E-mail for French-speaking HSB and Corporate Customers: support.euro.dell.com/ch/fr/emaildell/ Technical Support (Home and Small Business) Technical Support (Corporate) Customer Care (Home and Small Business) Customer Care (Corporate) Fax Switchboard	0844 811 411 0844 822 844 0848 802 202 0848 821 721 022 799 01 90 022 799 01 01
Taiwan International Access Code: 002 Country Code: 886	Technical Support (portable and desktop computers) Technical Support (servers) Transaction Sales Corporate Sales	toll-free: 00801 86 1011 toll-free: 0080 60 1256 toll-free: 0080 651 228 toll-free: 0080 651 227
Thailand International Access Code: 001 Country Code: 66	Technical Support Customer Service (Penang, Malaysia) Sales	toll-free: 0880 060 07 604 633 4949 toll-free: 0880 060 09
Trinidad/Tobago	General Support	1-800-805-8035
Turks and Caicos Islands	General Support	toll-free: 1-866-540-3355

Country (City) International Access Code Country Code City Code	Department Name or Service Area, Website and E-Mail Address	Area Codes, Local Numbers, and Toll-Free Numbers
U.K. (Bracknell)	Website: support.euro.dell.com	
International Access Code: 00	Customer Care website: support.euro.dell.com/uk/en/ECare/Form/Home.asp	
Country Code: 44		
City Code: 1344	E-mail: dell_direct_support@dell.com	
	Technical Support (Corporate/Preferred Accounts/PAD [1000+ employees])	0870 908 0500
	Technical Support (direct/PAD and general)	0870 908 0800
	Global Accounts Customer Care	01344 373 186
	Home and Small Business Customer Care	0870 906 0010
	Corporate Customer Care	01344 373 185
	Preferred Accounts (500–5000 employees) Customer Care	0870 906 0010
	Central Government Customer Care	01344 373 193
	Local Government & Education Customer Care	01344 373 199
	Health Customer Care	01344 373 194
	Home and Small Business Sales	0870 907 4000
	Corporate/Public Sector Sales	01344 860 456
	Home and Small Business Fax	0870 907 4006
Uruguay	General Support	toll-free: 000-413-598-2521
U.S. Virgin Islands	General Support	1-877-673-3355
Venezuela	General Support	8001-3605

SECTION 8

Appendix

Limited Warranties and Return Policy

Dell Inc. Ink and Toner Cartridges Limited Warranties

Dell Software License Agreement

Limited Warranties and Return Policy

Dell-branded hardware products purchased in the U.S. or Canada come with either a 90-day, one-year, two-year, three-year, or four-year limited warranty. To determine which warranty came with your hardware product(s), see your packing slip or invoice. The following sections describe the limited warranties and return policy for the U.S., the limited warranties and return policy for Canada, and the manufacturer guarantee for Latin America and the Caribbean.

Limited Warranty for Dell-Branded Hardware Products (U.S. Only)

What is covered by this limited warranty?

This limited warranty covers defects in materials and workmanship in your—our end-user customer's—Dell-branded hardware products, including Dell-branded peripheral products.

What is not covered by this limited warranty?

This limited warranty does not cover:

- Software, including the operating system and software added to the Dell-branded hardware products through our factory-integration system, third-party software, or the reloading of software
- Non-Dell-branded and Solution Provider Direct products and accessories
- Problems that result from:
 - External causes such as accident, abuse, misuse, or problems with electrical power
 - Servicing not authorized by Dell
 - Usage that is not in accordance with product instructions
 - Failure to follow the product instructions or failure to perform preventive maintenance
 - Problems caused by using accessories, parts, or components not supplied by Dell
- Products with missing or altered service tags or serial numbers
- Products for which we have not received payment

THIS WARRANTY GIVES YOU SPECIFIC LEGAL RIGHTS, AND YOU MAY ALSO HAVE OTHER RIGHTS WHICH VARY FROM STATE TO STATE (OR JURISDICTION TO JURISDICTION). DELL'S RESPONSIBILITY FOR MALFUNCTIONS AND DEFECTS IN HARDWARE IS LIMITED TO REPAIR AND REPLACEMENT AS SET FORTH IN THIS WARRANTY STATEMENT. ALL EXPRESS AND IMPLIED WARRANTIES FOR THE PRODUCT, INCLUDING BUT NOT LIMITED TO ANY IMPLIED WARRANTIES AND CONDITIONS OF MERCHANTABILITY AND FITNESS FOR A PARTICULAR PURPOSE, ARE LIMITED IN TIME TO THE TERM OF THE LIMITED WARRANTY PERIOD REFLECTED ON YOUR PACKING SLIP OR INVOICE. NO WARRANTIES, WHETHER EXPRESS OR IMPLIED, WILL APPLY AFTER THE LIMITED WARRANTY PERIOD HAS EXPIRED. SOME STATES DO NOT ALLOW LIMITATIONS ON HOW LONG AN IMPLIED WARRANTY LASTS, SO THIS LIMITATION MAY NOT APPLY TO YOU.

WE DO NOT ACCEPT LIABILITY BEYOND THE REMEDIES PROVIDED FOR IN THIS LIMITED WARRANTY OR FOR CONSEQUENTIAL OR INCIDENTAL DAMAGES, INCLUDING, WITHOUT LIMITATION, ANY LIABILITY FOR THIRD-PARTY CLAIMS AGAINST YOU FOR DAMAGES, FOR PRODUCTS NOT BEING AVAILABLE FOR USE, OR FOR LOST DATA OR LOST SOFTWARE. OUR LIABILITY WILL BE NO MORE THAN THE AMOUNT YOU PAID FOR THE PRODUCT THAT IS THE SUBJECT OF A CLAIM. THIS IS THE MAXIMUM AMOUNT FOR WHICH WE ARE RESPONSIBLE.

SOME STATES DO NOT ALLOW THE EXCLUSION OR LIMITATION OF INCIDENTAL OR CONSEQUENTIAL DAMAGES, SO THE ABOVE LIMITATION OR EXCLUSION MAY NOT APPLY TO YOU.

How long does this limited warranty last?

This limited warranty lasts for the time period indicated on your packing slip or invoice, except that the limited warranty on Dell-branded batteries lasts only one year and the limited warranty on the lamps for Dell-branded projectors lasts only ninety days. The limited warranty begins on the date of the packing slip or invoice. The warranty period is not extended if we repair or replace a warranted product or any parts. Dell may change the availability of limited warranties, at its discretion, but any changes will not be retroactive.

What do I do if I need warranty service?

Before the warranty expires, please call us at the relevant number listed in the following table. Please also have your Dell service tag number or order number available.

Individual Home Consumers:	U.S. Only
Technical Support	1-800-624-9896
Customer Service	1-800-624-9897
Individual Home Consumers who purchased through an Employee Purchase Program:	
Technical Support and Customer Service	1-800-822-8965
Home and Small Business Commercial Customers:	
Technical Support and Customer Service	1-800-456-3355
Medium, Large, or Global Commercial Customers, Healthcare Customers, and Value Added Resellers (VARs):	
Technical Support and Customer Service	1-877-459-7298
Government and Education Customers:	
Technical Support and Customer Service	1-877-459-7298
Dell-Branded Memory	1-888-363-5150

What will Dell do?

During the 90 days of the 90-day limited warranty and the first year of all other limited warranties: During the 90 days of the 90-day limited warranty and the first year of all other limited warranties, we will repair any Dell-branded hardware products returned to us that prove to be defective in materials or workmanship. If we are not able to repair the product, we will replace it with a comparable product that is new or refurbished.

When you contact us, we will issue a Return Material Authorization Number for you to include with your return. You must return the products to us in their original or equivalent packaging, prepay shipping charges, and insure the shipment or accept the risk if the product is lost or damaged in shipment. We will return the repaired or replacement products to you. We will pay to ship the repaired or replaced products to you if you use an address in the United States (excluding Puerto Rico and U.S. possessions and territories). Otherwise, we will ship the product to you freight collect.

If we determine that the product is not covered under this warranty, we will notify you and inform you of service alternatives that are available to you on a fee basis.

NOTE: Before you ship the product(s) to us, make sure to back up the data on the hard drive(s) and any other storage device(s) in the product(s). Remove any confidential, proprietary, or personal information and removable media such as floppy disks, CDs, or PC Cards. We are not responsible for any of your confidential, proprietary, or personal information; lost or corrupted data; or damaged or lost removable media.

During the remaining years: For the remaining period of the limited warranty, we will replace any defective part with new or refurbished parts, if we agree that it needs to be replaced. When you contact us, we will require a valid credit card number at the time you request a replacement part, but we will not charge you for the replacement part as long as you return the original part to us within thirty days after we ship the replacement part to you. If we do not receive the original part within thirty days, we will charge to your credit card the then-current standard price for that part.

We will pay to ship the part to you if you use an address in the United States (excluding Puerto Rico and U.S. possessions and territories). Otherwise, we will ship the part freight collect. We will also include a prepaid shipping container with each replacement part for your use in returning the replaced part to us.

NOTE: Before you replace parts, make sure to back up the data on the hard drive(s) and any other storage device(s) in the product(s). We are not responsible for lost or corrupted data.

What if I purchased a service contract?

If your service contract is with Dell, service will be provided to you under the terms of the service agreement. Please refer to that contract for details on how to obtain service.

If you purchased through us a service contract with one of our third-party service providers, please refer to that contract for details on how to obtain service.

How will you fix my product?

We use new and refurbished parts made by various manufacturers in performing warranty repairs and in building replacement parts and systems. Refurbished parts and systems are parts or systems that have been returned to Dell, some of which were never used by a customer. All parts and systems are inspected and tested for quality. Replacement parts and systems are covered for the remaining period of the limited warranty for the product you bought. Dell owns all parts removed from repaired products.

What do I do if I am not satisfied?

We pride ourselves on our great customer service. If you are not satisfied with the service you receive under this limited warranty, please let us know. We have found that the best way to resolve issues regarding our limited warranty is to work together. If, after those discussions, you are still not satisfied, we believe arbitration is the most expeditious way to resolve your concerns. Therefore, **ANY CLAIM, DISPUTE, OR CONTROVERSY (WHETHER IN CONTRACT, TORT, OR OTHERWISE, WHETHER PREEXISTING, PRESENT, OR FUTURE, AND INCLUDING STATUTORY, COMMON LAW, INTENTIONAL TORT, AND EQUITABLE CLAIMS) AGAINST DELL** arising from or relating to this limited warranty, its interpretation, or the breach, termination, or validity thereof, the relationships which result from this limited warranty (including, to the full extent permitted by applicable law, relationships with third parties), Dell's advertising, or any related purchase **SHALL BE RESOLVED EXCLUSIVELY AND FINALLY BY BINDING ARBITRATION ADMINISTERED BY THE NATIONAL ARBITRATION FORUM (NAF)** under its Code of Procedure then in effect (available via the Internet at www.arb-forum.com/ or via telephone at 1-800-474-2371). The arbitration will be limited solely to the dispute or controversy between you and Dell. Any award of the arbitrator(s) shall be final and binding on each of the parties, and may be entered as a judgment in any court of competent jurisdiction. Information may be obtained and claims may be filed with the NAF at P.O. Box 50191, Minneapolis, MN 55405. This provision applies only to individual home consumers and consumers who purchased through an employee purchase program. It does not apply to small, medium, large, and global commercial customers or government, education, and healthcare customers.

May I transfer the limited warranty?

Limited warranties on systems may be transferred if the current owner transfers ownership of the system and records the transfer with us. The limited warranty on Dell-branded memory may not be transferred. You may record your transfer by going to Dell's website:

- If you are an Individual Home Consumer, go to www.dell.com/us/en/dhs/topics/sbtopic_015_ccare.htm
- If you are a Home Office, Small, Medium, Large, or Global Commercial Customer, go to www.dell.com/us/en/biz/topics/sbtopic_ccare_nav_015_ccare.htm
- If you are a Government, Education, or Healthcare Customer, or an Individual Home Consumer who purchased through an employee purchase program, go to www.dell.com/us/en/pub/topics/sbtopic_015_ccare.htm

If you do not have Internet access, call your customer care representative or call 1-800-624-9897.

"Total Satisfaction" Return Policy (U.S. Only)

We value our relationship with you and want to make sure that you're satisfied with your purchases. That's why we offer a "Total Satisfaction" return policy for most products that you, the end-user customer, purchase directly from Dell. Under this policy, you may return to Dell products that you purchased directly from Dell for a credit or a refund of the purchase price paid, less shipping and handling and applicable return fees as follows:

- **New Hardware Products and Accessories** - Unless you have a separate agreement with Dell, all hardware, accessories, peripherals, parts, and unopened software still in its sealed package, excluding the products listed below, may be returned within twenty-one (21) days from the date on the packing slip or invoice. New PowerEdge™, PowerConnect™ and PowerVault™ products may be returned within thirty (30) days from the date on the packing slip or invoice except that new PowerEdge™ SC servers and n series products purchased from the Small and Medium Business Sales Division may only be returned within fourteen (14) days from the date on the packing slip or invoice. To return applications software or an operating system that has been installed by Dell, you must return the entire computer. A different return policy applies to nondefective products purchased through Dell's Software and Peripherals division by customers of our Small and Medium Business divisions. Those products may be returned within twenty-one (21) days from the date on the packing slip or invoice, but a fifteen percent (15%) return fee will be deducted from any refund or credit. The "Total Satisfaction" Return Policy and Software and Peripherals division return policy are not available for Dell | EMC storage products, EMC-branded products, Unisys-branded products, PowerVault™, 160T tape libraries, enterprise software, non-Dell branded enterprise products, software and/or software licenses purchased under any type of volume purchase agreement or any non-Dell customized hardware and/or software product(s).
- **Reconditioned or Refurbished Dell-Branded Hardware Products and Parts** - All reconditioned or refurbished PowerEdge™, PowerConnect™ and PowerVault™ products may be returned within thirty (30) days from the date on the packing slip or invoice. All other reconditioned or refurbished Dell-branded hardware products and parts may be returned within fourteen (14) days of the date on the packing slip or invoice.

How to Return

To return products, e-mail or call Dell customer service to receive a Credit Return Authorization Number within the return policy period applicable to the product you want to return. You must obtain a Credit Return Authorization Number in order to return the product. See "Contacting Dell" or "Getting Help" in your customer documentation (or www.dell.com/us/en/gen/contact.htm) to find the appropriate contact information for obtaining customer assistance.

You must ship the products to Dell within five (5) days of the date that Dell issues the Credit Return Authorization Number. You must also return the products to Dell in their original packaging, in as-new condition along with any media, documentation, and all other items that were included in the original shipment, prepay shipping charges, and insure the shipment or accept the risk of loss or damage during shipment.

Limited Warranty Terms for Dell-Branded Hardware Products (Canada Only)

What is covered by this limited warranty?

This limited warranty covers defects in materials and workmanship in your—our end-user customer's—Dell-branded hardware products, including Dell-branded peripheral products.

What is not covered by this limited warranty?

This limited warranty does not cover:

- Software, including the operating system and software added to the Dell-branded hardware products through our factory-integration system, or the reloading of the software
- Non-Dell branded and Solution Provider Direct products and accessories

- Problems that result from:
 - External causes such as accident, abuse, misuse, or problems with electrical power
 - Servicing not authorized by Dell
 - Usage that is not in accordance with product instructions
 - Failure to follow the product instructions or failure to perform preventive maintenance
 - Problems caused by using accessories, parts, or components not supplied by Dell
- Products with missing or altered service tags or serial numbers
- Products for which we have not received payment

THIS WARRANTY GIVES YOU SPECIFIC LEGAL RIGHTS, AND YOU MAY ALSO HAVE OTHER RIGHTS WHICH VARY FROM PROVINCE TO PROVINCE. DELL'S RESPONSIBILITY FOR MALFUNCTIONS AND DEFECTS IN PRODUCT IS LIMITED TO REPAIR AND REPLACEMENT AS SET FORTH IN THIS WARRANTY STATEMENT, FOR THE TERM OF THE WARRANTY PERIOD REFLECTED ON YOUR PACKING SLIP OR INVOICE. EXCEPT FOR THE EXPRESS WARRANTIES CONTAINED IN THIS WARRANTY STATEMENT, DELL DISCLAIMS ALL OTHER WARRANTIES AND CONDITIONS, EXPRESS OR IMPLIED, INCLUDING WITHOUT LIMITATION IMPLIED WARRANTIES AND CONDITIONS OF MERCHANTABILITY AND FITNESS FOR A PARTICULAR PURPOSE, STATUTORY OR OTHERWISE. SOME PROVINCES DO NOT ALLOW THE EXCLUSION OF CERTAIN IMPLIED WARRANTIES OR CONDITIONS, OR LIMITATIONS ON HOW LONG AN IMPLIED WARRANTY OR CONDITION LASTS. THEREFORE, THE FOREGOING EXCLUSIONS AND LIMITATIONS MAY NOT APPLY TO YOU.

WE DO NOT ACCEPT LIABILITY BEYOND THE REMEDIES PROVIDED FOR IN THIS WARRANTY STATEMENT OR FOR SPECIAL, INDIRECT, CONSEQUENTIAL, OR INCIDENTAL DAMAGES, INCLUDING, WITHOUT LIMITATION, ANY LIABILITY FOR THIRD-PARTY CLAIMS AGAINST YOU FOR DAMAGES, FOR PRODUCTS NOT BEING AVAILABLE FOR USE, OR FOR LOST DATA OR LOST SOFTWARE. OUR LIABILITY WILL BE NO MORE THAN THE AMOUNT YOU PAID FOR THE PRODUCT THAT IS THE SUBJECT OF A CLAIM. THIS IS THE MAXIMUM AMOUNT FOR WHICH WE ARE RESPONSIBLE.

SOME PROVINCES DO NOT ALLOW THE EXCLUSION OR LIMITATION OF SPECIAL, INDIRECT, INCIDENTAL, OR CONSEQUENTIAL DAMAGES, SO THE ABOVE LIMITATION OR EXCLUSION MAY NOT APPLY TO YOU.

How long does this limited warranty last?

This limited warranty lasts for the time period indicated on your packing slip or invoice, except that the limited warranty on Dell-branded batteries lasts only one year and the limited warranty on the lamps for Dell-branded projectors lasts only ninety days. The limited warranty begins on the date of the packing slip or invoice. The warranty period is not extended if we repair or replace a warranted product or any parts. Dell may change the terms and availability of limited warranties, at its discretion, but any changes will not be retroactive (that is, the warranty terms in place at the time of purchase will apply to your purchase).

What do I do if I need warranty service?

Before the warranty expires, please call us at the relevant number listed in the following table. Please also have your Dell service tag number or order number available.

Individual Home Consumers; Home Office and Small Business Customers:	Canada Only
Technical Support and Customer Service	1-800-847-4096
Medium, Large, and Global Commercial Customers; Government, Education, and Healthcare Customers; and Value Added Resellers (VARs):	
Technical Support	1-800-387-5757
Customer Service	1-800-326-9463
Government or Education Customers, or Individual Home Consumers who purchased through an Employee Purchase Program:	
Technical Support	1-800-387-5757
Customer Service	1-800-326-9463 (Extension 8221 for Individual Consumers)
Dell-Branded Memory	1-888-363-5150

What will Dell do?

During the 90 days of the 90-day limited warranty and the first year of all other limited warranties: During the 90 days of the 90-day limited warranty and the first year of all other limited warranties, we will repair any Dell-branded hardware products returned to us that prove to be defective in materials or workmanship. If we are not able to repair the product, we will replace it with a comparable product that is new or refurbished.

When you contact us, we will issue a Return Material Authorization Number for you to include with your return. You must return the products to us in their original or equivalent packaging, prepay shipping charges, and insure the shipment or accept the risk if the product is lost or damaged in shipment. We will return the repaired or replacement products to you. We will pay to ship the repaired or replaced products to you if you use an address in Canada. Otherwise, we will ship the product to you freight collect.

If we determine that the problem is not covered under this warranty, we will notify you and inform you of service alternatives that are available to you on a fee basis.

NOTE: Before you ship the product(s) to us, make sure to back up the data on the hard drive(s) and any other storage device(s) in the product(s). Remove any confidential, proprietary or personal information, removable media, such as floppy disks, CDs, or PC Cards. We are not responsible for any of your confidential, proprietary or personal information; lost or corrupted data; or damaged or lost removable media.

During the remaining years following the first year of all limited warranties: We will replace any defective part with new or refurbished parts, if we agree that it needs to be replaced. When you contact us, we will require a valid credit card number at the time you request a replacement part, but we will not charge you for the replacement part as long as you return the original part to us within thirty days after we ship the replacement part to you. If we do not receive the original part within thirty days, we will charge to your credit card the then-current standard price for that part.

We will pay to ship the part to you if you use an address in Canada. Otherwise, we will ship the part freight collect. We will also include a prepaid shipping container with each replacement part for your use in returning the replaced part to us.

NOTE: Before you replace parts, make sure to back up the data on the hard drive(s) and any other storage device(s) in the product(s). We are not responsible for lost or corrupted data.

What if I purchased a service contract?

If your service contract is with Dell, service will be provided to you under the terms of the service contract. Please refer to that contract for details on how to obtain service. Dell's service contracts can be found online at www.dell.ca or by calling Customer Care at 1-800-847-4096. If you purchased through us a service contract with one of our third-party service providers, please refer to that contract (mailed to you with your packing slip or invoice) for details on how to obtain service.

How will you fix my product?

We use new and refurbished parts made by various manufacturers in performing warranty repairs and in building replacement parts and systems. Refurbished parts and systems are parts or systems that have been returned to Dell, some of which were never used by a customer. All parts and systems are inspected and tested for quality. Replacement parts and systems are covered for the remaining period of the limited warranty for the product you bought. Dell owns all parts removed from repaired products.

What do I do if I am not satisfied?

We pride ourselves on our great customer service. If you are not satisfied with the service you receive under this limited warranty, please let us know. We have found that the best way to resolve issues regarding our limited warranty is to work together. If, after those discussions, you are still not satisfied, we believe arbitration is the most expeditious way to resolve your concerns. Therefore, **ANY CLAIM, DISPUTE, OR CONTROVERSY (WHETHER IN CONTRACT, TORT, OR OTHERWISE, WHETHER PREEXISTING, PRESENT OR FUTURE, AND INCLUDING STATUTORY, COMMON LAW, INTENTIONAL TORT, AND EQUITABLE CLAIMS) AGAINST DELL** arising from or relating to this limited warranty, its interpretation, or the breach, termination or validity thereof, the relationships which result from this limited warranty (including, to the full extent permitted by applicable law, relationships with third parties), Dell's advertising, or any related purchase **SHALL BE RESOLVED EXCLUSIVELY AND FINALLY BY BINDING ARBITRATION ADMINISTERED BY THE NATIONAL ARBITRATION FORUM (NAF)** under its Code of Procedure then in effect (available via the Internet at www.arb-forum.com/, or via telephone at 1-800-474-2371). The arbitration will be limited solely to the dispute or controversy between you and Dell. Any award of the arbitrator(s) shall be final and binding on each of the parties, and may be entered as a judgment in any court of competent jurisdiction. Information may be obtained and claims may be filed with the NAF at P.O. Box 50191, Minneapolis, MN 55405.

May I transfer the limited warranty?

Limited warranties on systems may be transferred if the current owner transfers ownership of the system and records the transfer with us. The limited warranty on Dell-branded memory may not be transferred. You may record your transfer by going to Dell's website:

- For Canada-purchased computers (in-country transfers) and to transfer from one customer to another, go to www.dell.ca/ca/en/gen/topics/segtopic_ccare_nav_013_ccare.htm
- For out-of-country transfers (outside of the original country of purchase), go to www.dell.com/us/en/biz/topics/sbtopic_ccare_nav_016_ccare.htm

If you do not have Internet access, call Dell at 1-800-847-4096 (Home Consumer customers) or 1-800-326-9463 (Corporate Commercial or Government customers).

"Total Satisfaction" Return Policy (Canada Only)

If you are an end-user customer who bought new products directly from Dell, you may return them to Dell up to 30 days after you receive them for a refund or credit of the product purchase price. If you are an end-user customer who bought reconditioned or refurbished products from Dell, you may return them to Dell within 14 days after the date on the packing slip or invoice for a refund or credit of the product purchase price. In either case, the refund or credit will not include any shipping and handling charges shown on your packing slip or invoice and will be subject to a fifteen percent (15%) restocking fee, unless otherwise prohibited by law. If you are an organization that bought the products under a written agreement with Dell, the agreement may contain different terms for the return of products than specified by this policy.

To return products, you must call Dell Customer Service at 1-800-847-4096 to receive a Credit Return Authorization Number. To expedite the process of your refund or credit, Dell expects you to return the products to Dell in their original packaging within five days of the date that Dell issues the Credit Return Authorization Number. You must also prepay shipping charges and insure the shipment or accept the risk of loss or damage during shipment. You may return software for a refund or credit only if the sealed package containing the floppy disk(s) or CD(s) is unopened. Returned products must be in as-new condition, and all of the manuals, floppy disk(s), CD(s), power cables, and other items included with a product must be returned with it. For customers who want to return, for refund or credit only, either application or operating system software that has been installed by Dell, the whole system must be returned, along with any media and documentation that may have been included in the original shipment.

The "Total Satisfaction" Return Policy does not apply to Dell | EMC storage products. It also does not apply to products purchased through Dell's Software and Peripherals division. For those products, please instead refer to Dell's Software and Peripheral's then-current return policy (see the following section, "Dell Software and Peripherals (Canada Only)").

Dell Software and Peripherals (Canada Only)

Third-Party Software and Peripherals Products

Similar to other resellers of software and peripherals, Dell does not warrant third-party products. Third-party software and peripheral products are covered by the warranties provided by the original manufacturer or publisher only. Third-party manufacturer warranties vary from product to product. Consult your product documentation for specific warranty information. More information may also be available from the manufacturer or publisher.

While Dell offers a wide selection of software and peripheral products, we do not specifically test or guarantee that all of the products we offer work with any or all of the various models of Dell computers, nor do we test or guarantee all of the products we sell on the hundreds of different brands of computers available today. If you have questions about compatibility, we recommend and encourage you to contact the third-party software and peripheral product manufacturer or publisher directly.

Dell-Branded Peripheral Products

Dell does provide a limited warranty for new Dell-branded peripheral products (products for which Dell is listed as the manufacturer) such as monitors, batteries, memory, docking stations, and projectors). To determine which limited warranty applies to the product you purchased, see the Dell packing slip or invoice and/or the product documentation that accompanied your product. Descriptions of Dell's limited warranties are described in preceding sections.

Return Policy

If you are an end-user customer who bought Dell Software and Peripherals products directly from a Dell company, you may return Dell Software and Peripherals products that are in as-new condition to Dell up to 30 days from the date on the packing slip or invoice for a refund of the product purchase price if already paid. This refund will not include any shipping and handling charges shown on your packing slip or invoice; you are responsible for those.

To return products, you must call Dell Customer Service at 1-800-387-5759 to receive a Credit Return Authorization Number. You must ship the Dell Software and Peripherals products back to Dell in their original manufacturer's packaging (which must be in as-new condition), prepay shipping charges, and insure the shipment or accept the risk of loss or damage during shipment.

To qualify for refund or replacement, returned products must be in as-new condition, software products must be unopened, and all of the manuals, floppy disk(s), CD(s), power cables, and other items included with a product must be returned with it.

One-Year End-User Manufacturer Guarantee (Latin America and the Caribbean Only)

Guarantee

Dell Inc. ("Dell") warrants to the end user in accordance with the following provisions that its branded hardware products, purchased by the end user from a Dell company or an authorized Dell distributor in Latin America or the Caribbean, will be free from defects in materials, workmanship, and design affecting normal use, for a period of one year from the original purchase date. Products for which proper claims are made will, at Dell's option, be repaired or replaced at Dell's expense. Dell owns all parts removed from repaired products. Dell uses new and reconditioned parts made by various manufacturers in performing repairs and building replacement products.

Exclusions

This Guarantee does not apply to defects resulting from: improper or inadequate installation, use, or maintenance; actions or modifications by unauthorized third parties or the end user; accidental or willful damage; or normal wear and tear.

Making a Claim

Claims must be made in Latin America or the Caribbean by contacting the Dell point of sale within the guarantee period. The end user must always supply proof of purchase, indicating name and address of the seller, date of purchase, model and serial number, name and address of the customer, and details of symptoms and configuration at the time of malfunction, including peripherals and software used. Otherwise, Dell may refuse the guarantee claim. Upon diagnosis of a warranted defect, Dell will make arrangements and pay for ground freight and insurance to and from Dell's repair/replacement center. The end user must ensure that the defective product is available for collection properly packed in original or equally protective packaging together with the details listed above and the return number provided to the end user by Dell.

Limitation and Statutory Rights

Dell makes no other warranty, guarantee or like statement other than as explicitly stated above, and this Guarantee is given in place of all other guarantees whatsoever, to the fullest extent permitted by law. In the absence of applicable legislation, this Guarantee will be the end user's sole and exclusive remedy against Dell or any of its affiliates, and neither Dell nor any of its affiliates shall be liable for loss of profit or contracts, or any other indirect or consequential loss arising from negligence, breach of contract, or howsoever.

This Guarantee does not impair or affect mandatory statutory rights of the end user against and/or any rights resulting from other contracts concluded by the end user with Dell and/or any other seller.

Dell World Trade LP

One Dell Way, Round Rock, TX 78682, USA

Dell Computadores do Brasil Ltda (CNPJ No. 72.381.189/0001-10)/

Dell Commercial do Brasil Ltda (CNPJ No. 03 405 822/0001-40)

Avenida Industrial Belgraf, 400

92990-000 - Eldorado do Sul – RS - Brasil

Dell Computer de Chile Ltda

Coyancura 2283, Piso 3- Of.302,

Providencia, Santiago - Chile

Dell Computer de Colombia Corporation

Carrera 7 #115-33 Oficina 603

Bogota, Colombia

Dell Computer de Mexico SA de CV

Paseo de la Reforma 2620 - 11° Piso

Col. Lomas Altas

11950 México, D.F.

Dell Inc. Ink and Toner Cartridges Limited Warranties

The following sections describe the limited warranty for ink and toner cartridges for the U.S., Canada, and Latin America. Refer to the appropriate limited warranty accordingly.

Ink and Toner Cartridges Limited Warranty (U.S. and Canada Only)

Dell Inc. warrants to the original purchaser of genuine Dell-branded toner cartridges that they will be free from defects in material and workmanship for the life of the cartridge and that for genuine Dell-branded ink cartridges they will be free from defects in material and workmanship for two years beginning on the date of invoice. If this product proves defective in either material or workmanship, it will be replaced without charge during the limited warranty period if returned to Dell. You must first call our toll-free number to get your return authorization. In the U.S., call 1-800-822-8965; in Canada, call 1-800-387-5757. If we are not able to replace the product because it has been discontinued or is not available, we will either replace it with a comparable product or reimburse you for the cartridge purchase cost, at Dell's sole option. This limited warranty does not apply to ink or toner cartridges that have been refilled or improperly stored or due to problems resulting from misuse, abuse, accident, neglect, mishandling, incorrect environments, or wear from ordinary use.

THIS WARRANTY GIVES YOU SPECIFIC LEGAL RIGHTS, AND YOU MAY ALSO HAVE OTHER RIGHTS WHICH VARY FROM STATE TO STATE (OR JURISDICTION TO JURISDICTION). DELL'S RESPONSIBILITY FOR MALFUNCTIONS AND DEFECTS IN HARDWARE IS LIMITED TO REPLACEMENT AS SET FORTH IN THIS WARRANTY STATEMENT. FOR CANADIAN CUSTOMERS, EXCEPT FOR THE EXPRESS WARRANTIES CONTAINED IN THIS WARRANTY STATEMENT, DELL DISCLAIMS ALL OTHER WARRANTIES AND CONDITIONS, EXPRESS OR IMPLIED, STATUTORY OR OTHERWISE, FOR THE PRODUCT. FOR U.S. CUSTOMERS, ALL EXPRESS AND IMPLIED WARRANTIES FOR THE PRODUCT, INCLUDING BUT NOT LIMITED TO ANY IMPLIED WARRANTIES AND CONDITIONS OF MERCHANTABILITY AND FITNESS FOR A PARTICULAR PURPOSE ARE LIMITED IN TIME TO THE TERM OF THIS LIMITED WARRANTY. NO WARRANTIES, WHETHER EXPRESS OR IMPLIED, WILL APPLY AFTER THE LIMITED WARRANTY PERIOD HAS EXPIRED. SOME STATES OR JURISDICTIONS DO NOT ALLOW THE EXCLUSION OF CERTAIN IMPLIED WARRANTIES OR CONDITIONS, OR LIMITATIONS ON HOW LONG AN IMPLIED WARRANTY OR CONDITION LASTS, SO THIS LIMITATION MAY NOT APPLY TO YOU. THIS WARRANTY COVERAGE TERMINATES IF YOU SELL OR OTHERWISE TRANSFER THIS PRODUCT TO ANOTHER PARTY.

DELL DOES NOT ACCEPT LIABILITY BEYOND THE REMEDIES PROVIDED FOR IN THIS LIMITED WARRANTY OR FOR SPECIAL, INDIRECT, CONSEQUENTIAL OR INCIDENTAL DAMAGES, INCLUDING, WITHOUT LIMITATION, ANY LIABILITY FOR THIRD-PARTY CLAIMS AGAINST YOU FOR DAMAGES, FOR PRODUCTS NOT BEING AVAILABLE FOR USE, OR FOR LOST DATA OR LOST SOFTWARE. DELL'S LIABILITY WILL BE NO MORE THAN THE AMOUNT YOU PAID FOR THE PRODUCT THAT IS THE SUBJECT OF A CLAIM. THIS IS THE MAXIMUM AMOUNT FOR WHICH DELL IS RESPONSIBLE.

SOME STATES OR JURISDICTIONS DO NOT ALLOW THE EXCLUSION OR LIMITATION OF SPECIAL, INDIRECT, INCIDENTAL OR CONSEQUENTIAL DAMAGES, SO THE ABOVE LIMITATION OR EXCLUSION MAY NOT APPLY TO YOU.

Ink and Toner Cartridges Limited Warranty (Latin America Only)

Dell Inc. warrants to the original purchaser of genuine Dell-branded toner cartridges that the cartridges will be free from defects resulting from material or manufacturing process for the life of the cartridge. For the original purchaser of genuine Dell-branded ink cartridges, Dell warrants that the cartridges will be free from defects resulting from material or manufacturing process for one year beginning from the date of delivery.

If this product presents defects resulting from either material or manufacturing process, it will be replaced without charge during the limited warranty period if returned to Dell.

In order to obtain the necessary information to enable the replacement, call the appropriate toll-free number. In Mexico, call 001-877-533-6230; in Puerto Rico, call 1-877-839-5123. In cases in which either the production of the cartridge has been discontinued or the cartridge is not available, Dell reserves the right, at its sole discretion, to choose between replacing it by a similar product or reimbursing you for the purchase cost.

This limited warranty does not apply to ink or toner cartridges that have been refilled or to defects resulting from misuse, abuse, accident, negligence, mishandling, improper storage or exposure to inappropriate environments.

Dell's liability for the malfunction or defect of hardware after the period of the legal warranty (and specifically the period of the legal warranty of defective products stated in the consumer protections rules), is limited to either the substitution of the product or the reimbursement as stated above. This warranty coverage terminates if you sell or otherwise transfer this product to a third party.

Dell does not accept any additional liability for patrimonial, emotional or any other kind of damage caused to the consumer and/or to a third party, which exceeds the established liability either in this limited warranty or in legal rules that may apply.

Dell Software License Agreement

This is a legal agreement between you, the user, and Dell Products, L.P. ("Dell"). This agreement covers all software that is distributed with the Dell product, for which there is no separate license agreement between you and the manufacturer or owner of the software (collectively the "Software"). By opening or breaking the seal on the Software packet(s), installing or downloading the Software, or using the Software that has been preloaded or is embedded in your computer, you agree to be bound by the terms of this agreement. If you do not agree to these terms, promptly return all Software items (disks, written materials, and packaging) and delete any preloaded or embedded Software.

You may use one copy of the Software on only one computer at a time. If you have multiple licenses for the Software, you may use as many copies at any time as you have licenses. "Use" means loading the Software in temporary memory or permanent storage on the computer. Installation on a network server solely for distribution to other computers is not "use" if (but only if) you have a separate license for each computer to which the Software is distributed. You must ensure that the number of persons using the Software installed on a network server does not exceed the number of licenses that you have. If the number of users of Software installed on a network server will exceed the number of licenses, you must purchase additional licenses until the number of licenses equals the number of users before allowing additional users to use the Software. If you are a commercial customer of Dell or a Dell affiliate, you hereby grant Dell, or an agent selected by Dell, the right to perform an audit of your use of the Software during normal business hours, you agree to cooperate with Dell in such audit, and you agree to provide Dell with all records reasonably related to your use of the Software. The audit will be limited to verification of your compliance with the terms of this agreement.

The Software is protected by United States copyright laws and international treaties. You may make one copy of the Software solely for backup or archival purposes or transfer it to a single hard disk provided you keep the original solely for backup or archival purposes. You may not rent or lease the Software or copy the written materials accompanying the Software, but you may transfer the Software and all accompanying materials on a permanent basis if you retain no copies and the recipient agrees to the terms hereof. Any transfer must include the most recent update and all prior versions. You may not reverse engineer, decompile or disassemble the Software. If the package accompanying your computer contains compact discs, 3.5" and/or 5.25" disks, you may use only the disks appropriate for your computer. You may not use the disks on another computer or network, or loan, rent, lease, or transfer them to another user except as permitted by this agreement.

Limited Warranty

Dell warrants that the Software disks will be free from defects in materials and workmanship under normal use for ninety (90) days from the date you receive them. This warranty is limited to you and is not transferable. Any implied warranties are limited to ninety (90) days from the date you receive the Software. Some jurisdictions do not allow limits on the duration of an implied warranty, so this limitation may not apply to you. The entire liability of Dell and its suppliers, and your exclusive remedy, shall be (a) return of the price paid for the Software or (b) replacement of any disk not meeting this warranty that is sent with a return authorization number to Dell, at your cost and risk. This limited warranty is void if any disk damage has resulted from accident, abuse, misapplication, or service or modification by someone other than Dell. Any replacement disk is warranted for the remaining original warranty period or thirty (30) days, whichever is longer.

Dell does NOT warrant that the functions of the Software will meet your requirements or that operation of the Software will be uninterrupted or error free. You assume responsibility for selecting the Software to achieve your intended results and for the use and results obtained from the Software.

DELL, ON BEHALF OF ITSELF AND ITS SUPPLIERS, DISCLAIMS ALL OTHER WARRANTIES, EXPRESS OR IMPLIED, INCLUDING, BUT NOT LIMITED TO, IMPLIED WARRANTIES OF MERCHANTABILITY AND FITNESS FOR A PARTICULAR PURPOSE, FOR THE SOFTWARE AND ALL ACCOMPANYING WRITTEN MATERIALS. This limited warranty gives you specific legal rights; you may have others, which vary from jurisdiction to jurisdiction.

IN NO EVENT SHALL DELL OR ITS SUPPLIERS BE LIABLE FOR ANY DAMAGES WHATSOEVER (INCLUDING, WITHOUT LIMITATION, DAMAGES FOR LOSS OF BUSINESS PROFITS, BUSINESS INTERRUPTION, LOSS OF BUSINESS INFORMATION, OR OTHER PECUNIARY LOSS) ARISING OUT OF USE OR INABILITY TO USE THE SOFTWARE, EVEN IF ADVISED OF THE POSSIBILITY OF SUCH DAMAGES. Because some jurisdictions do not allow an exclusion or limitation of liability for consequential or incidental damages, the above limitation may not apply to you.

U.S. Government Restricted Rights

The software and documentation are "commercial items" as that term is defined at 48 C.F.R. 2.101, consisting of "commercial computer software" and "commercial computer software documentation" as such terms are used in 48 C.F.R. 12.212. Consistent with 48 C.F.R. 12.212 and 48 C.F.R. 227.7202-1 through 227.7202-4, all U.S. Government end users acquire the software and documentation with only those rights set forth herein. Contractor/manufacturer is Dell Products, L.P., One Dell Way, Round Rock, Texas 78682.

General

This license is effective until terminated. It will terminate upon the conditions set forth above or if you fail to comply with any of its terms. Upon termination, you agree that the Software and accompanying materials, and all copies thereof, will be destroyed. This agreement is governed by the laws of the State of Texas. Each provision of this agreement is severable. If a provision is found to be unenforceable, this finding does not affect the enforceability of the remaining provisions, terms, or conditions of this agreement. This agreement is binding on successors and assigns. Dell agrees and you agree to waive, to the maximum extent permitted by law, any right to a jury trial with respect to the Software or this agreement. Because this waiver may not be effective in some jurisdictions, this waiver may not apply to you. You acknowledge that you have read this agreement, that you understand it, that you agree to be bound by its terms, and that this is the complete and exclusive statement of the agreement between you and Dell regarding the Software.

Index

C

- card stock
 - sizes and weights, 28
- cards, installing, 17
- clearing paper jams, 60
- connect the printer
 - Ethernet cable, 38
 - parallel cable, 30
 - USB cable, 30

D

- Dell
 - contacting, 65
- Dell Toner Management System, 44
- driver profiler, using, 46

E

- envelopes
 - sizes and weights, 28
- Ethernet cable,
 - connecting, 38

I

- imaging drum

- replacing, 57
- installing
 - optional cards, 17
 - optional drawer, 14
 - optional memory, 17
- printer drivers
 - using Windows 2000, 32
 - using Windows 98, 34
 - using Windows Me, 33
 - using Windows NT, 33
 - using Windows XP, 31

J

- jams, 60

L

- labels
 - sizes and weights, 28
- loading paper
 - standard and optional trays, 22
- local printer settings utility,
 - using, 45

M

- media, 28
 - types and sizes, 28

- memory, installing, 17

O

- optional drawer, installing, 14
- ordering supplies, 2

P

- paper
 - jams, 60
 - sizes and weights, 28
- paper jams
 - clearing, 60
- parallel cable, connecting, 30
- photoconductor kit
 - see imaging drum
- print media guidelines, 27
- printer
 - memory, 17
- printer configuration Web tool, using, 47
- printer software uninstall,
 - using, 46
- printer supplies reorder application, using, 45
- printing
 - local, 29

- media guidelines, 27
- menu settings page, 39
- network, 37
- network setup page, 39

S

- set IP address utility, using, 45
- software applications
 - Dell Toner Management System, 44
 - driver profiler, 46
 - local printer settings utility, 45
 - printer supplies reorder application, 45
 - set IP address utility, 45
 - status monitor center, 44
 - uninstall, 46
- status monitor center, using, 44
- supplies, ordering, 2
- support
 - contacting Dell, 65

T

- toner cartridge
 - replacing, 54
- toner, ordering, 2
- transparencies
 - sizes and weights, 28
- trays, loading, 22
- troubleshooting, 50
 - basic problems, 50

- clearing paper jams, 60
- replacing the imaging drum, 57
- replacing the toner cartridge, 54

U

- uninstall software, 46
- USB cable, connecting, 30

W

- warranty, 84
- Web server, using, 47

Free Manuals Download Website

<http://myh66.com>

<http://usermanuals.us>

<http://www.somanuals.com>

<http://www.4manuals.cc>

<http://www.manual-lib.com>

<http://www.404manual.com>

<http://www.luxmanual.com>

<http://aubethermostatmanual.com>

Golf course search by state

<http://golfingnear.com>

Email search by domain

<http://emailbydomain.com>

Auto manuals search

<http://auto.somanuals.com>

TV manuals search

<http://tv.somanuals.com>