

# CRYSTAL AUDIO



## System Series

## Operating Instructions

© 2000 Crystal Audio

## Table of contents

Information about this manual.....	2
Connecting the speakers.....	3
Positioning the speakers.....	4
Adjusting your amplifier for the System Series Speakers.....	5
Precautions.....	5
Specifications.....	6

## Information about this manual

This instruction manual is referred to the following speaker models:

System 2

System 4

System Dipole 4

System Center 4

System 5

System 6

System Center 6

SystemBass twin 7

System 8

SystemBass 10

SystemBass 12R

**Please read this instruction manual before using the System Series Speakers.**

## Connecting the speakers

This section explains how to connect your speakers to your amplifier.

- Before connecting the speakers make sure that your amplifier is turned off.
- Turn off the subwoofer before connecting the input signal cable on its internal amplifier.
- Connect the plus (+) and minus (-) terminals of each speaker to the corresponding plus (+) and minus (-) terminals on the amplifier.
- If a biwire type of connection is used (except System 2, System 5 and System Dipole 4 that have single wire binding posts), the gold plated bridges must be taken off. Unscrew the binding post's screws and pull off the two bridges. Tighten the screws.
- If you use bare speaker wire at the speaker terminals, remove the binding post's screw and place the bare wire into the side opening of the terminal. Then tighten the screw.
- If a banana plug type is used, just push the plug into the binding post's top hole.

Figure 1 shows a typical system connection of two front speakers, two rear speakers, one center speaker and one subwoofer on a AV amplifier for 5.1 channel reproduction.

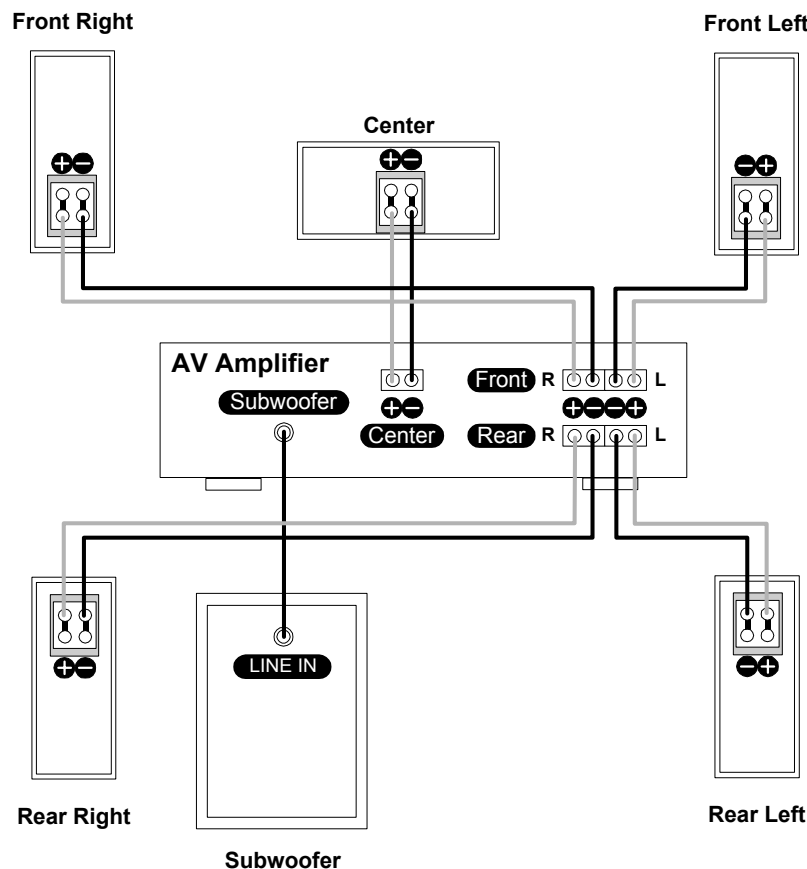

Figure 1. Typical connection of 5.1 channel configuration.

## Positioning the speakers

- Each speaker must have approximately the same distance from the listening position in order to have a better stereo sound image.
- The front speakers must be placed on an imaginary arc that includes the position of the center speaker. Thus, the front speakers and the center speaker will have the same distance from the listening position.
- The center speaker must be placed on top or beneath of the television. If you place it beneath the television, you must give it an angle in order to face the listeners.
- The tweeters of the front and center speakers must be be at the same height with a sitting listener's ear. If needed, bases can be used.
- The rear speakers should be dipoles and are best located to the side of or behind the listening position, at least 0.6m (2 feet) above the listening position.
- The subwoofer must be placed as close as possible to the listening position, e.g. beside or at the back of the couch.

### Note

Carpets, curtains and furniture improve sound quality in the listening room, since they reduce reflections of sound.

Figure 2 shows a typical placement of the speakers in the music-home theater room.

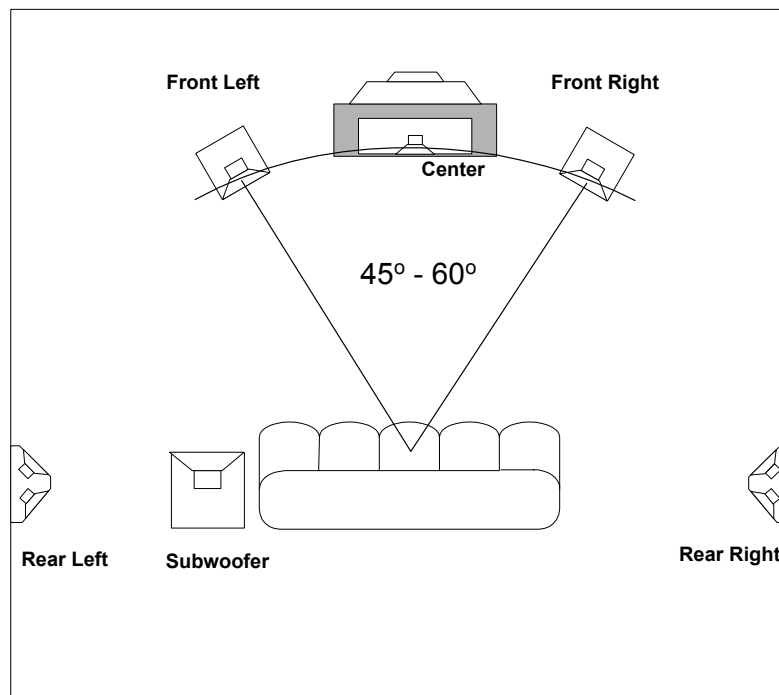

Figure 2.

## Adjusting your amplifier for the System Series

All System Series Speakers are designed for use with subwoofer. The adjustments that must be made on the setup menu of your AV amplifier are:

Speaker	Menu on AV amplifier about the size of the speaker
Front	SMALL
Rear	SMALL
Center	SMALL

Also you must adjust the amplifier so that it recognizes that a subwoofer is present (Subwoofer YES or ON).

These adjustments are very important for the protection of your speakers.

## Precautions

- The AV amplifier you use must be set to SMALL position for all the System Series Speakers (front, rear & center).
- Before operating a subwoofer, make sure that the operating voltage of the local power supply and the subwoofer are identical.
- Before connecting the speakers make sure that your amplifier is turned off.
- Turn off the subwoofer before connecting the input signal cable on its internal amplifier.
- Make sure that you have connected the plus (+) and minus (-) terminals of each speaker to the corresponding plus (+) and minus (-) terminals on the amplifier.
- Make sure that all screws on the binding posts are tight enough, especially if you are using bare speaker wires. A contact between bare speaker wires may cause short-circuit which can damage your equipment.
- Avoid the use of Treble - Bass adjustments and Loudness especially at high level output. Also avoid the use of equalizers. In this way you protect your speakers and you get better sound with less distortion.
- The possibility of damaging your speakers is greater if you use low power amplifiers that operate at their limits especially with the Treble – Bass adjustments at their maximum value.  
Such amplifiers clip very easily, which can destroy your speakers. Tweeters are more vulnerable on this kind of use.  
Therefore, high power amplifiers are more preferable.
- Do not drive each speaker with a continuous wattage exceeding the maximum power indicated on this instruction manual for the specified speaker.

- Use the best speaker and interconnect cables you can afford.
- Do not place the speakers in dusty, humid environment.
- Avoid exposure to direct sunlight.

## Specifications

Model	System 2	System 4	System 6	System 8
Speaker	2 way	2 way	3 way	3 way
Magnetically shielded	v	v	v	v
Woofer 3" aluminum concave	2	4	6	8
Tweeter 1" aluminum dome	-	1	1	1
Tweeter 1" neodymium magnet, ceramic dome	1	-	-	-
Impedance	8	8	6	4
Frequency Response (Hz – kHz)	120-25	110-25	100-25	90-25
Nominal input power in SMALL mode (Watt RMS)	80	100	125	150
Maximum input power (Watt)	160	200	250	300
Sensitivity (dB/2.83V/1m)	91	92	92	92
Enclosure Type :Bass reflex	v	v	v	v
Single Wire Binding Post Gold Plated	v	-	-	-
Biwire Binding Post Gold Plated	-	v	v	v
Dimensions (WxHxD) mm	110x270x80	110x1090x80	110x1210x80	110x1310x105

Model	System 5	System Dipole 4	System Center 4	System Center 6
Speaker	2 way	2 way	2 way	3 way
Magnetically shielded	v	v	v	v
Woofer 3" aluminum concave	8	4	4	6
Tweeter 1" aluminum dome	1	2	1	-
Tweeter 1" neodymium magnet, ceramic dome	-	-	-	1
Impedance	4	8	8	6
Frequency Response (Hz – kHz)	90-25	110-25	110-25	100-25
Nominal input power in SMALL mode (Watt RMS)	150	100	100	125
Maximum input power (Watt)	300	200	200	250
Sensitivity (dB/2.83V/1m)	92	92	92	92
Enclosure Type :Bass reflex	v	v	v	v

Single Wire Binding Post Gold Plated	v	v	-	-
Biwire Binding Post Gold Plated	-	-	v	v
Dimensions (WxHxD) mm	110x270x110 s 220x160x110 c	240x300x120	500x110x80	585x160x108

Model	SystemBass twin 7	SystemBass 10	SystemBass 12R
Active subwoofer	v	v	v
Woofers	2x7"	10"	12"
Impedance	4	4	4
Frequency Response (Hz)	24-160	20-160	19-160
Nominal input power in SMALL mode (Watt RMS)	90	170	200
Sensitivity (dB/2.83V/1m)	92	93	94
Remote controlled, Volume & Frequency control on remote	-	-	v
Enclosure Type :Bass reflex	v	v	v
Auto Power ON/OFF	v	v	v
Dimensions (WxHxD) mm	210x375x420	340x505x435	340x505x455

For System 5 in dimensions box are s stands for satellites and c stands for center.

Specifications are subject to change without notice.

## Free Manuals Download Website

<http://myh66.com>

<http://usermanuals.us>

<http://www.somanuals.com>

<http://www.4manuals.cc>

<http://www.manual-lib.com>

<http://www.404manual.com>

<http://www.luxmanual.com>

<http://aubethermostatmanual.com>

Golf course search by state

<http://golfingnear.com>

Email search by domain

<http://emailbydomain.com>

Auto manuals search

<http://auto.somanuals.com>

TV manuals search

<http://tv.somanuals.com>