



# Installation, Start-Up and Service Instructions

## CONTENTS

	Page
<b>SAFETY CONSIDERATIONS</b> .....	1
<b>INTRODUCTION</b> .....	1
<b>INSTALLATION</b> .....	1-58
<b>Step 1 — Inspection</b> .....	1
<b>Step 2 — Install Roof Curb</b> .....	1
• STAND-ALONE APPLICATIONS	
• COUPLED APPLICATIONS	
<b>Step 3 — Rigging and Handling</b> .....	45
• MOUNTING THE UNIT INDOORS	
<b>Step 4 — Installing ERV Transitions</b> .....	47
• ERV UNIT COUPLED WITH A 3 TO 12 1/2 TON HVAC UNIT	
<b>Step 5 — Make Electrical Connections</b> .....	47
• POWER SUPPLY	
• ELECTRICAL CONNECTIONS	
<b>START-UP</b> .....	59-75
<b>Unit Preparation</b> .....	59
<b>Internal Wiring</b> .....	59
<b>Rain Hoods</b> .....	59
<b>Energy Recovery Wheel</b> .....	59
• DRIVE BELT	
• AIR SEALS	
<b>Blower Rotation</b> .....	59
<b>Airflow Settings and Adjustments</b> .....	59
• FACTORY SETTING	
• CURVE SELECTION	
• ADJUST THE ERV BLOWER SPEED	
• MEASURE MOTOR VOLTAGE, AMPERAGE AND FAN RPM	
• BELT MAINTENANCE	
<b>Variable Air Volume Option</b> .....	74
<b>Operating Sequence</b> .....	74
• OCCUPIED MODE	
• UNOCCUPIED MODE	
<b>SERVICE</b> .....	75-78
<b>Removing Wheel Segments for Cleaning   (62M170-950 Units)</b> .....	75
<b>Removing and Installing Non-Segmented   Wheel for Cleaning (62M040 Units)</b> .....	75
<b>Removing and Installing Non-Segmented   Wheel for Cleaning (62M075,120 Units)</b> .....	76
<b>Installing Wheel Segments (62M170-950 Units)</b> .....	76
<b>Wheel Drive Motor and Pulley Replacement</b> .....	77
<b>Belt Replacement</b> .....	77
<b>MAINTENANCE</b> .....	78,79
<b>START UP CHECKLIST</b> .....	CL-1

## SAFETY CONSIDERATIONS

Installation and servicing of air-conditioning equipment can be hazardous due to system pressure and electrical components. Only trained and qualified service personnel should install, repair, or service air-conditioning equipment.

Untrained personnel can perform the basic maintenance functions of cleaning coils and filters and replacing filters. All other operations should be performed by trained service personnel. When working on air-conditioning equipment, observe precautions in the literature, tags and labels attached to the unit, and other safety precautions that may apply.

Follow all safety codes. Wear safety glasses and work gloves. These instructions describe how to install, start up, and service 62M energy recovery ventilator units.

### **▲ WARNING**

Electrical shock can cause personal injury and death. Shut off all power to this equipment during installation. There may be more than one disconnect switch. Tag all disconnect locations to alert others not to restore power until work is completed.

## INTRODUCTION

The 62M energy recovery ventilator (ERV) units recover energy from building exhaust air and pre-condition ventilation air. All ERV units are available in either vertical discharge (through the bottom) or horizontal discharge configuration.

The 62MB and MC vertical discharge units are used when a stand-alone ERV unit is required.

The 62MD and ME horizontal discharge unit can be used as a stand-alone unit, or can also be coupled with a Carrier rooftop unit.

## INSTALLATION

**Step 1 — Inspection** — Inspect the unit; file a claim with the shipping company if the unit is damaged. Check the packing list to ensure that the correct items have been received and notify your Carrier representative of any discrepancy.

### **Step 2 — Install Roof Curb**

**STAND-ALONE APPLICATIONS** — The ERV unit can be installed without being coupled with a Carrier rooftop unit. The ERV units can be installed in one of three stand-alone applications: down discharge, horizontal discharge, or a combination of both down discharge and horizontal discharge.

When installing a stand-alone ERV unit refer to Fig. 1-45 and, complete the following:

Locate the Roof Curb — Prior to locating the roof curb consider the structural support required for the rooftop system and, the duct drop location in relation to the joists. Allow sufficient space for service, clearance, and locations of vents or other sources of air.

### **⚠ WARNING**

Cover roof opening if installation of the ERV unit will not be immediate. Failure to cover roof opening could result in water damage and/or serious personal injury.

**Assemble the Roof Curb** — Connect the curb side and the curb end. See Fig. 1. Insert the tabs on the curb end into the slots on the curb sides. Press firmly until the pieces lock into place. It may be necessary to exert additional force to the top of the curb to lock the pieces in place. Ensure the curb pieces are locked together prior to proceeding.

Repeat for all corners of the roof curb.

**Prepare Roof Curb Location** — Cut a hole in the roof for duct openings. See Fig. 2-5 for duct opening dimensions. Frame the opening to provide adequate structural support.

**Install Deck Pans and Duct Supports** — The roof curb may have a duct support and deck pans, depending on the model and application. Determine which end of the roof curb will be the duct end.

Install the deck pans on the roof curb with the insulation side facing up toward the ERV base. Install the duct support between the supply and return openings.

**Set the Roof Curb** — Fit the roof curb assembly by measuring across the corners of the curb to ensure a square fit. Set the roof curb over the roof opening. Level the curb by placing shims under the bottom flange of the curb. Secure the curb in place by welding or fastening the curb to the roof.

### **⚠ WARNING**

Cover the roof curb if installation of the ERV unit will not be immediate. Failure to cover the roof curb could result in water damage and/or serious personal injury.

**Install Ductwork** — Ductwork will be installed in the roof curb for vertical discharge and stand-alone applications. The duct will hang from the top of the curb. See Fig. 45 for stand-alone application airflow.

**NOTE:** Ductwork must be installed before the ERV unit is set in place.

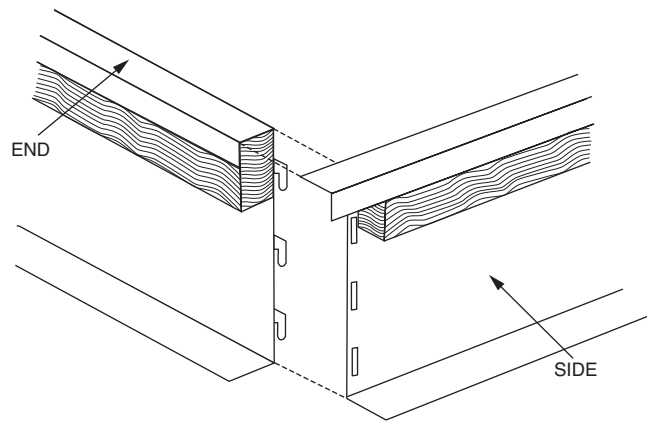
Refer to Fig. 2-5 to determine the duct size required. Provide field manufactured duct and place into the supply and return openings in the curb.

**Install Gaskets** — The ERV roof curbs come with a gasketing package to provide a seal between the ERV unit and the top perimeter of the roof curb. Install the gasket around the top perimeter of the curb and around the supply and return opening.

**NOTE:** Some stand-alone curbs will not have duct openings). Gasket strips must fit tightly together, leaving no gaps for leakage.

**IMPORTANT:** Gasket installation is critical for water integrity. Improperly installed gaskets can result in air or water leaks, leading to poor unit performance.

**Install Roofing Materials** — Insulate and add a cant strip to the roof curb. Follow suggested and acceptable roofing practices



**Fig. 1 — Assembling the Roof Curb**

for applying roofing materials. The roofing material should extend up to the wood nailer and be secured under the counter-flashing. Follow all local, national, and industry roofing standards. Refer to Fig. 6 for roofing recommendations.

**COUPLED APPLICATIONS** — The ERV unit can be installed directly coupled to a Carrier rooftop unit. The connection between the ERV and HVAC (Heating, Ventilation, and Air Conditioning) unit is made with the use of a transition. In a coupled rooftop application there is a separate roof curb for the HVAC curb and a separate roof curb for the ERV unit. See Fig. 4 and 5 for roof curb dimensions.

**Locate the Roof Curb** — Prior to locating the roof curb consider the structural support required for the rooftop system and, the duct drop location in relation to the joists. Allow sufficient space for service, clearance, and locations of vents or other sources of air. Refer to the rooftop installation instructions for more information regarding location considerations.

**Assemble the Roof Curb** — Connect the curb side and the curb end. Insert the tabs on the curb end into the slots on the curb sides. Press firmly until the pieces lock in to place. It may be necessary to exert additional force to the top of the curb to lock the pieces in place. Ensure the curb pieces are locked together prior to proceeding.

Repeat for other corners of the roof curb.

**NOTE:** If lifting or moving the roof curb assembly hammer the tabs over 90 degrees.

**Install Deck Pans and Duct Supports** — The roof curb may have a duct support and deck pans, depending on the model and application. Refer to Fig. 2-5. Determine which end of the roof curb will be the duct end.

Install the deck pans on the roof curb with the insulation side facing up toward the ERV base. Install the duct support between the supply and return openings.

**Install Locator Pieces** — Some ERV roof curbs (62MA-CRB-14MC and 62MB-CRB-14MC) will include locator pieces, which are to be attached to the ERV roof curb section. The locator pieces will help the installer ensure that the ERV and HVAC unit roof curbs are positioned properly. Attach the 2 side locator pieces to the ERV roof curb. Install the cover panel over the 2 sides and fasten in place.

**Set the Roof Curb** — Fit the roof curb assembly by measuring across the corners of the curb to ensure a square fit. Set the roof curb over the roof opening. Level the curb by placing shims under the bottom flange of the curb. Secure the curb in place by welding or fastening the curb to the roof.

**IMPORTANT:** The ERV roof curb must be set in precisely the correct location relative to the rooftop roof curb for the transitions to connect properly. See Fig. 7-44 for location dimensions.

**Install Ductwork** — Ductwork will be installed in the roof curb for vertical, coupled applications. The duct will hang from the top of the curb.

**NOTE:** Ductwork must be installed before the rooftop unit is set in place.

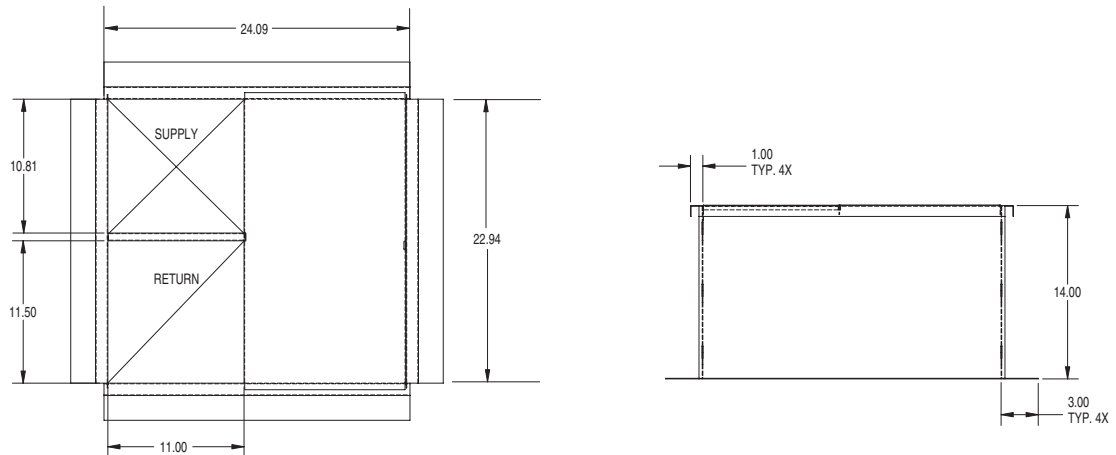
**NOTE:** Ductwork must be installed before the ERV unit is set in place.

Refer to Fig. 2 and 3 to determine the duct size required. Provide field manufactured duct and place into the supply and return openings in the curb.

**Install Gaskets** — The ERV roof curbs come with a gasketing package to provide a seal between the ERV unit and the top perimeter of the roof curb. Install the gasket around the top perimeter of the curb and around the supply and return opening. (Some stand-alone curbs will not have duct openings.) Gasket strips must fit tightly together, leaving no gaps for leakage.

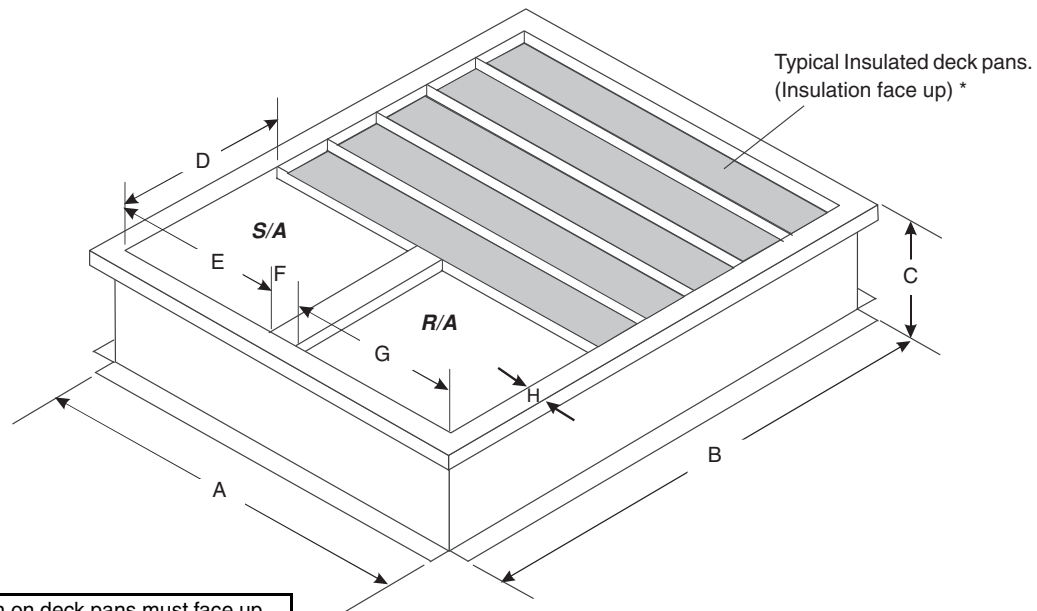
**IMPORTANT:** Gasket installation is critical for water integrity. Improperly installed gaskets can result in air or water leaks, leading to poor unit performance.

**Install Roofing Materials** — Insulate and add a cant strip to the roof curb. Follow suggested and acceptable roofing procedures for applying roofing materials. The roofing material should extend up to the wood nailer and be secured under the counter flashing. Follow all local, national, and industry roofing standards. Refer to Fig. 5 for roofing recommendations.



- NOTES:**
1. All dimensions are in inches.
  2. Roof curb shipped unassembled.

**Fig. 2 — Roof Curb — 62M040 for Stand-Alone Applications**



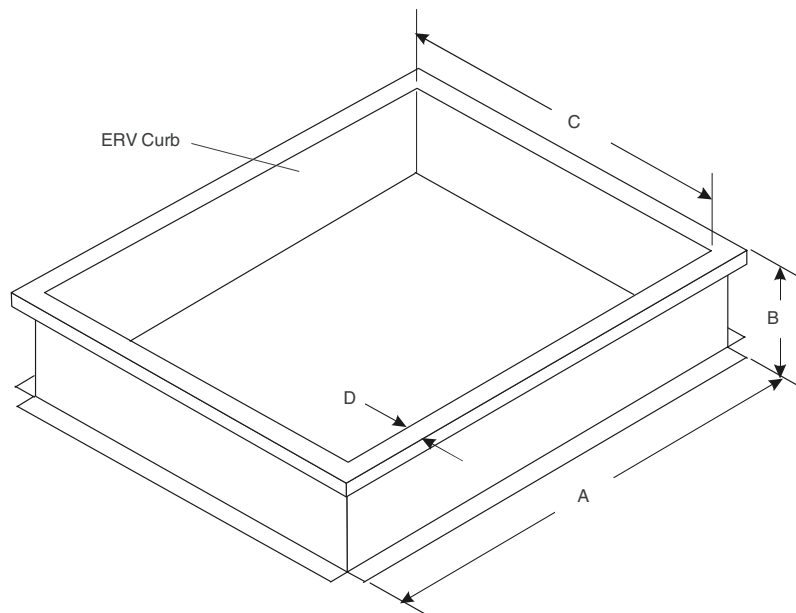
LEGEND  
 R/A — Return Air  
 S/A — Supply Air

**\*IMPORTANT:** Insulation on deck pans must face up.

NOTE: Roof curb shipped unassembled.

62M UNIT SIZE	CURB PART NO.	DIMENSIONS (in.)									
		A	B	C	D	E	F	G	H	Duct Sizes	
										Return	Supply
075,120	62M-A-CRB-14S	27	30.5	14	14	11.3	1	14.7	1.5	13.75 x 14.38	13.75 x 11
170-285	62M-B-CRB-14S	45.5	49.63	14	17.5	19.5	2	24	1.75	17 x 23.5	17 x 19
330-640	62M-C-CRB-14S	55.41	60.34	14	24.84	23.41	2	30	—	24.5 x 29.5	24.5 x 23
750,950	62M-D-CRB-14S	86.25	95.7	14	32.5	42.13	2	42.13	—	32 x 41.75	32 x 41.75

**Fig. 3 — Roof Curb — 62M075-950 for Vertical Stand-Alone Applications**

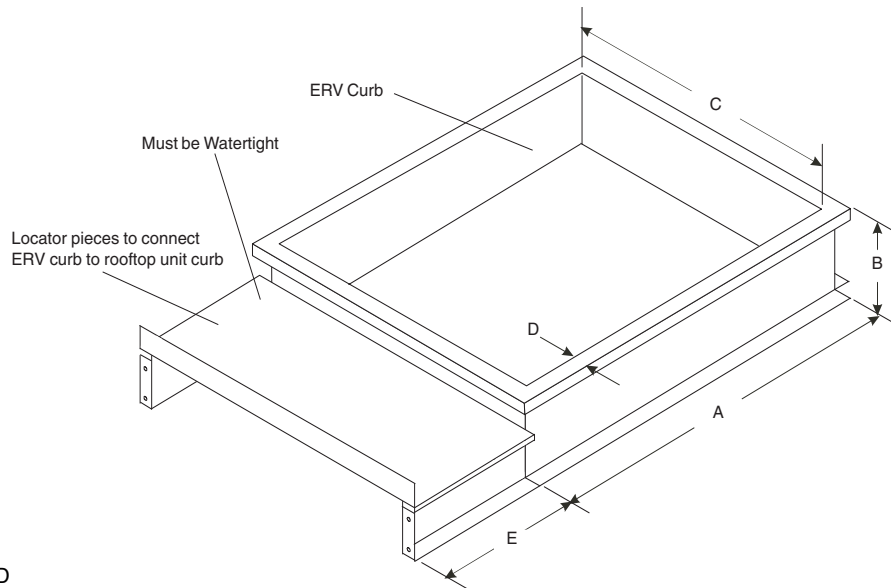


LEGEND  
 ERV — Energy Recovery Ventilator  
 NOTE: Roof curb shipped unassembled.

62M UNIT SIZE	CURB PART NO.	DIMENSIONS (in.)			
		A	B	C	D
075,120*	62M-A-CRB-14S	27	30.5	14	1.5
170-285†	62M-B-CRB-14S	49.63	14	45.5	1.75
330-640	62M-C-CRB-14M	60.34	14	55.41	1.75
750,950	62M-D-CRB-14M	95.7	14	86.25	1.75

\*62M075,120 curb is shipped with deckpans insulation and duct supports which may be discarded.  
 †62M170-285 curb is shipped with deck pans and insulation.

**Fig. 4 — Roof Curb — 62M075-950 for Horizontal Stand-Alone Applications or Units Coupled with Rooftop Units 15 Tons and Above**



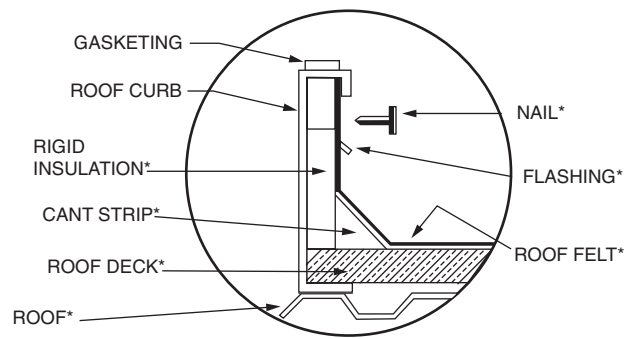
**LEGEND**

**ERV** — Energy Recovery Ventilator

NOTE: Roof curb shipped unassembled.

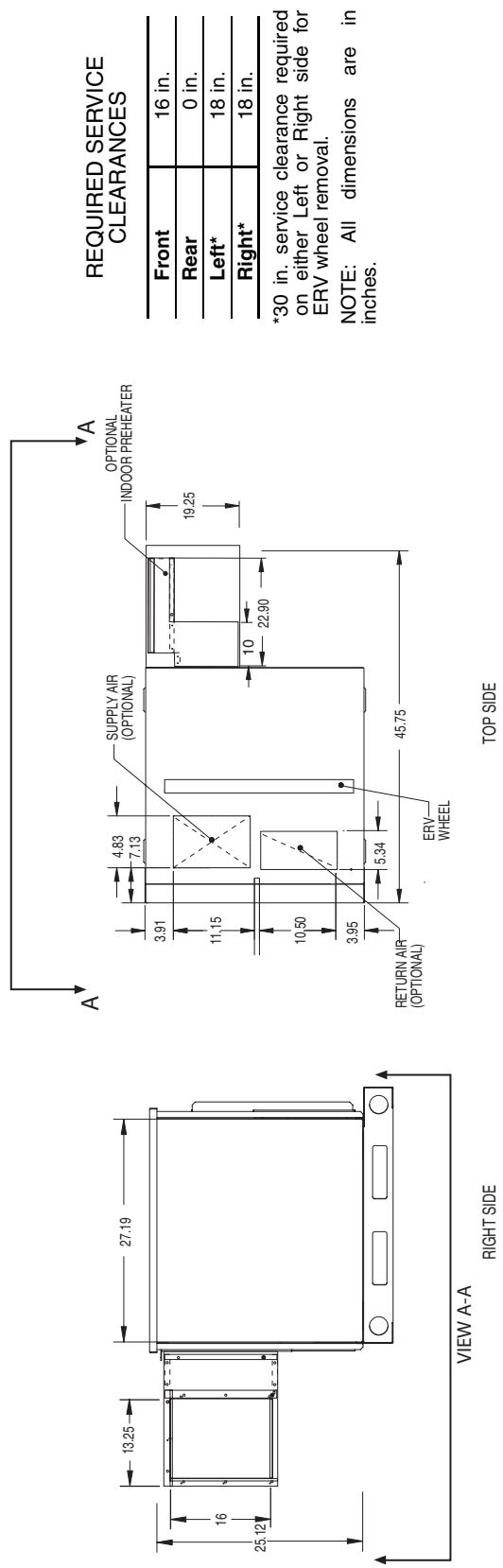
62M UNIT SIZE	CURB PART NO.	DIMENSIONS (in.)				
		A	B	C	D	E
075,120	62M-A-CRB-14MC	30.5	14	27	1.5	19.81
170-285	62M-B-CRB-14MC	49.63	14	45.5	1.75	37.81

**Fig. 5 — Roof Curb — 62M075-285 Units 3 to 12<sup>1</sup>/<sub>2</sub> Ton Rooftop Units**



\*Field provided.

**Fig. 6 — Roofing Materials — Recommendation**

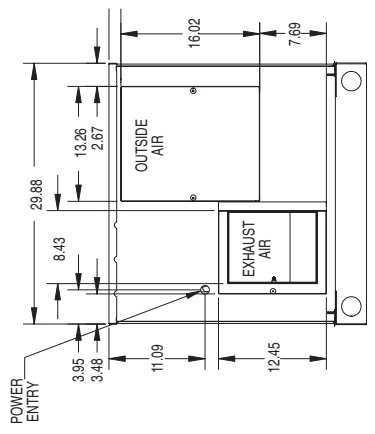


**REQUIRED SERVICE CLEARANCES**

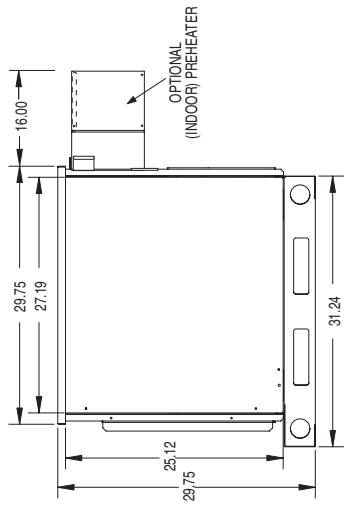
<b>Front</b>	16 in.
<b>Rear</b>	0 in.
<b>Left*</b>	18 in.
<b>Right*</b>	18 in.

\*30 in. service clearance required on either Left or Right side for ERV wheel removal.  
NOTE: All dimensions are in inches.

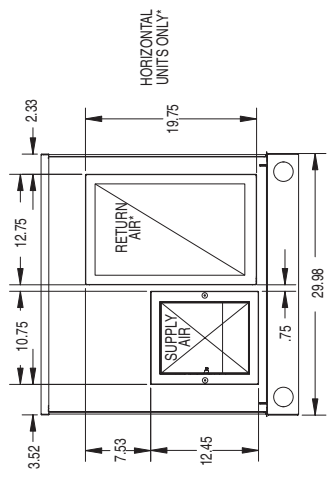
VIEW A-A RIGHT SIDE  
TOP SIDE



FRONT SIDE



LEFT SIDE



REAR SIDE

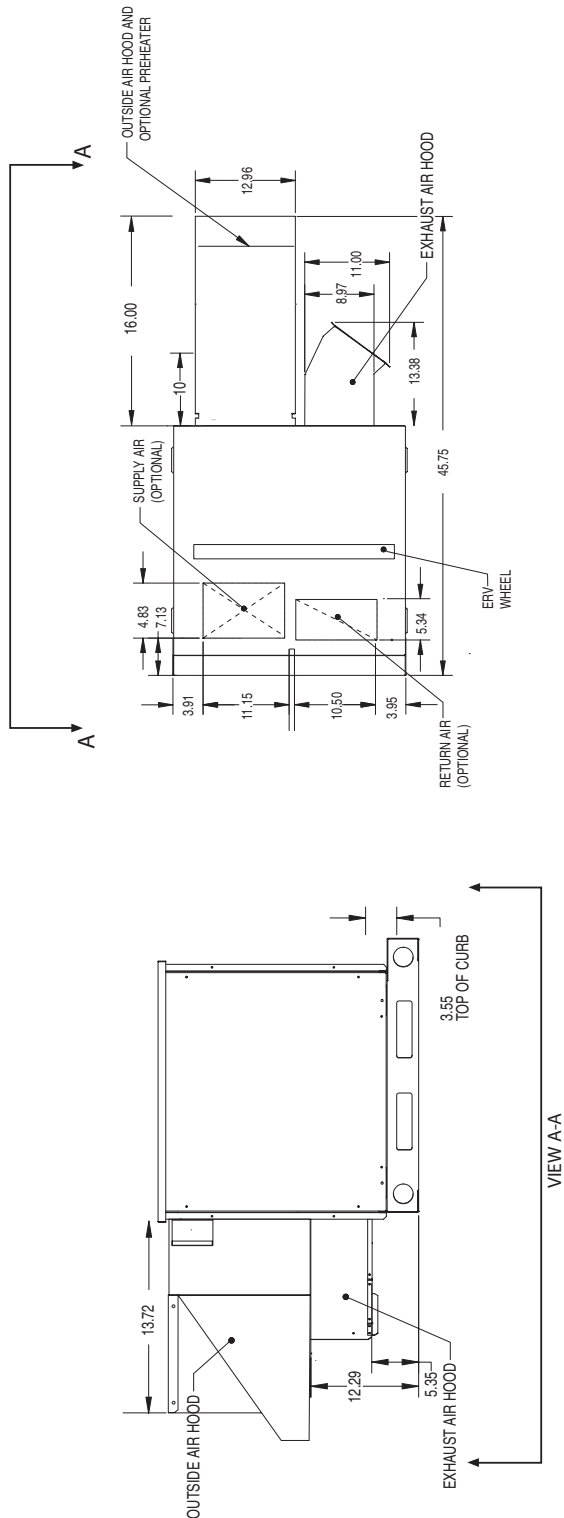
**Fig. 7 — 62MB, MC040 Indoor Unit Dimensions**

**REQUIRED SERVICE CLEARANCES**

<b>Front</b>	27.5 in.
<b>Rear</b>	10 in.
<b>Left*</b>	20 in.
<b>Right*</b>	20 in.

\*30 in. service clearance required on either Left or Right side for ERV wheel removal.

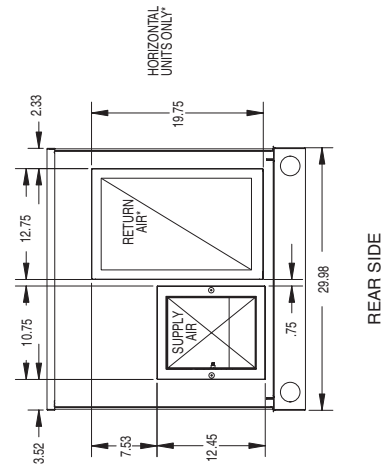
NOTE: All dimensions are in inches.



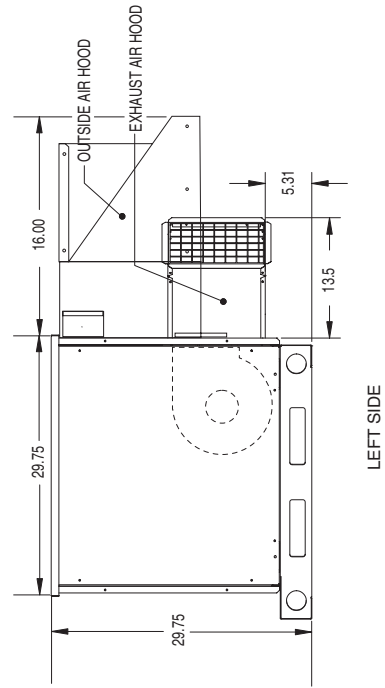
VIEW A-A

RIGHT SIDE

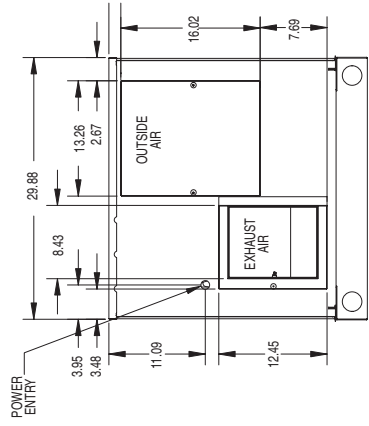
TOP SIDE



REAR SIDE

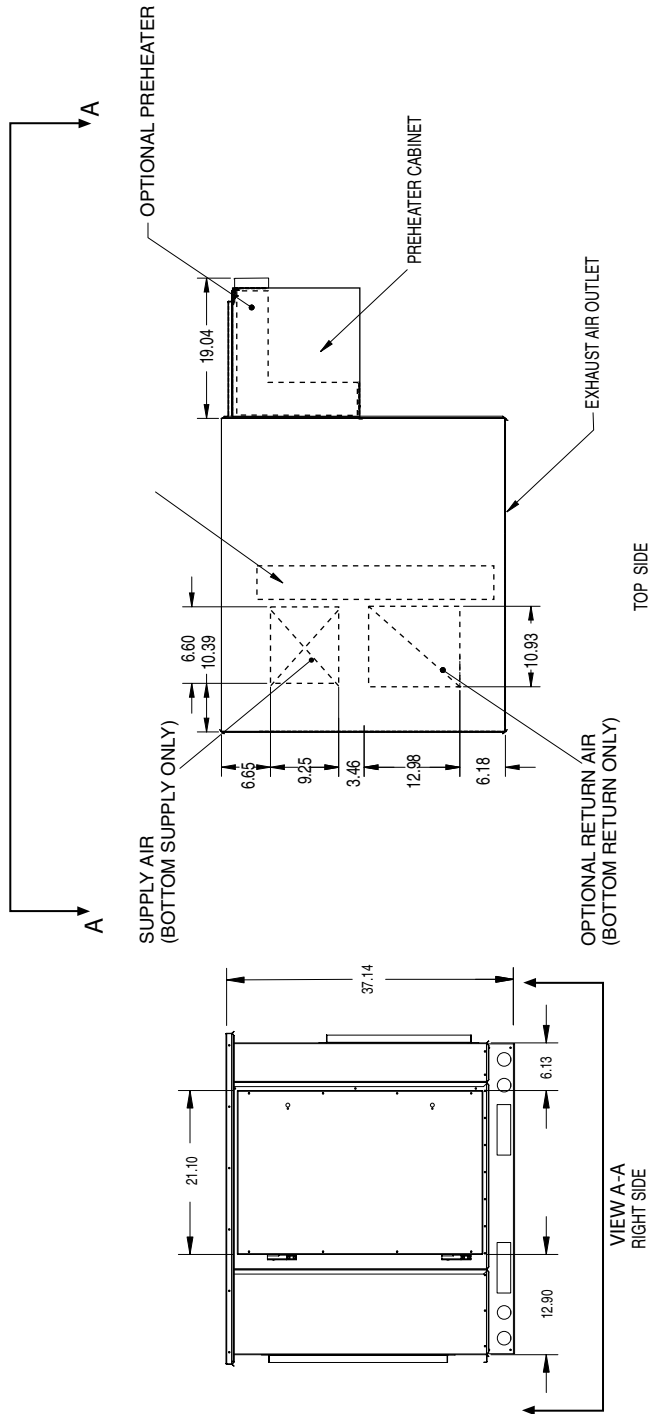


LEFT SIDE



FRONT SIDE

**Fig. 8 — 62MD, ME040 Outdoor Unit Dimensions**

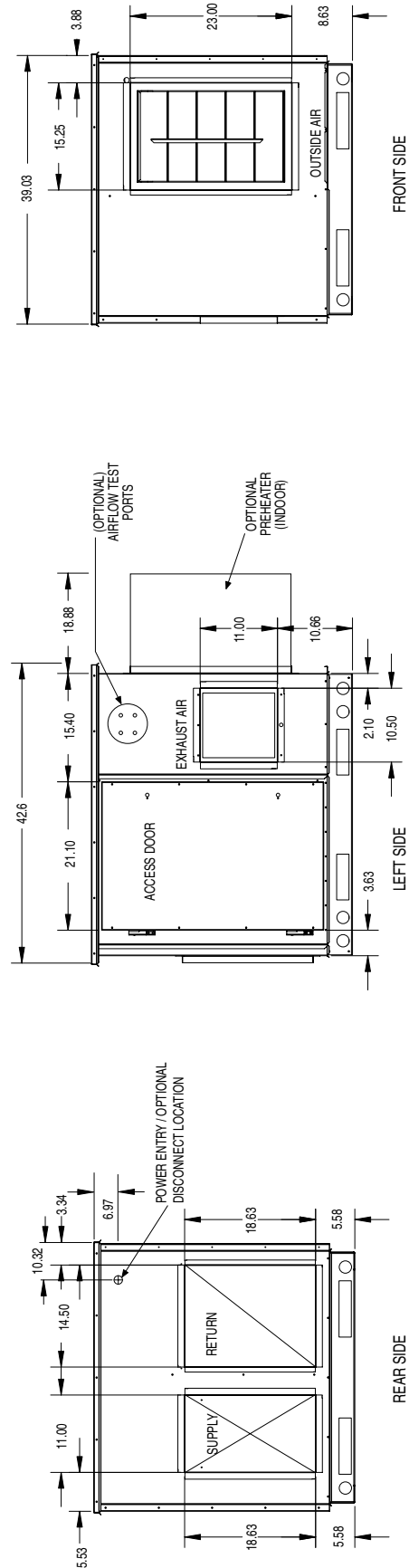


**REQUIRED SERVICE CLEARANCES**

Front	31 in.
Rear	0 in.
Left	24 in.
Right*	39 in.

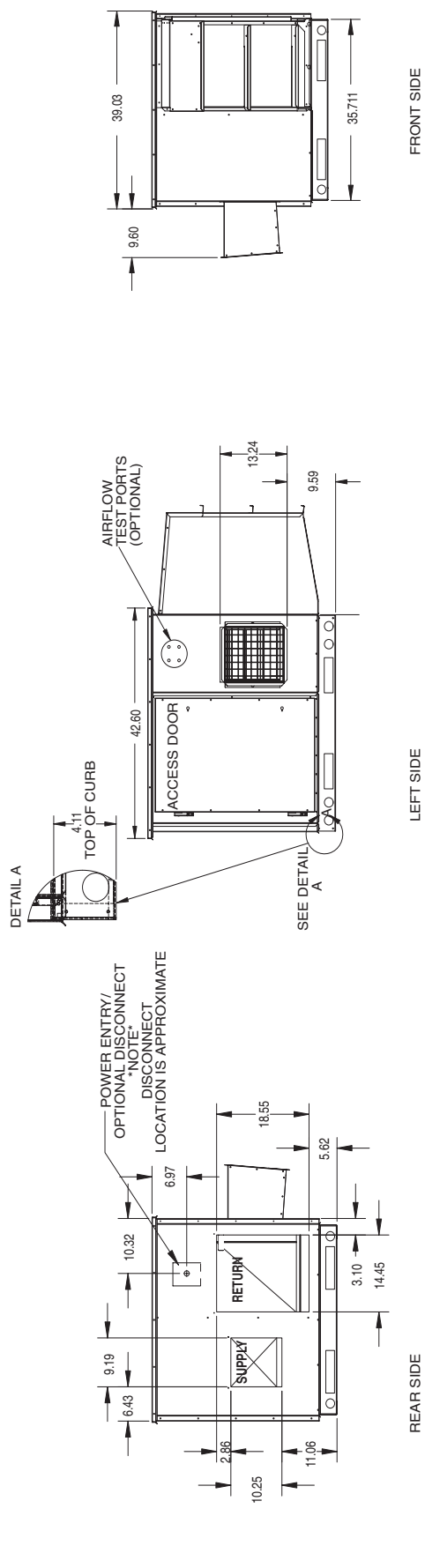
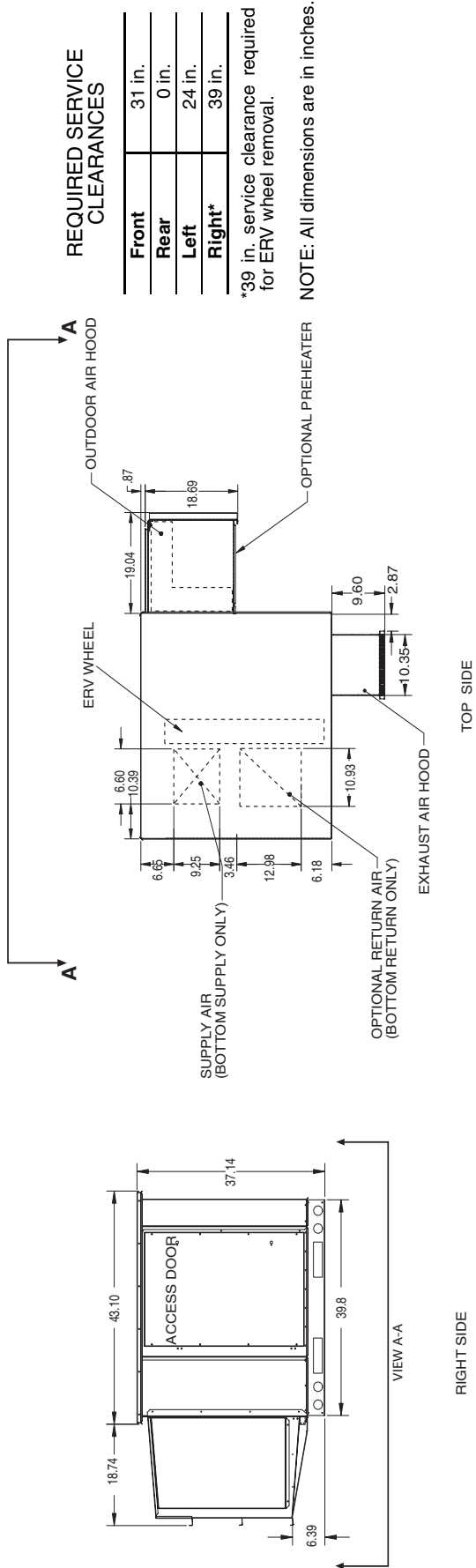
\*39 in. service clearance required for ERV wheel removal.

NOTE: All dimensions are in inches.

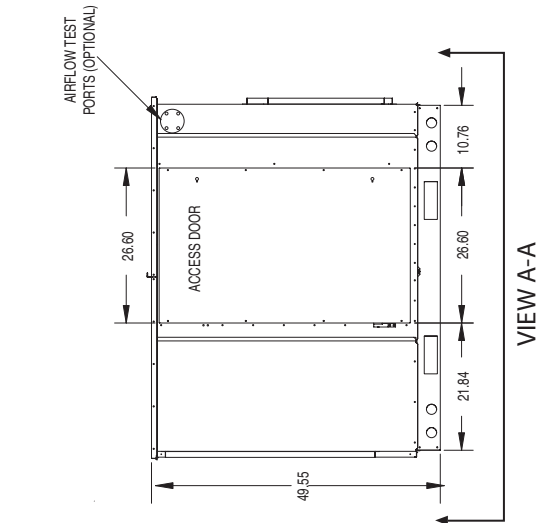


**Fig. 9 — 62MB, MC075, 120 Indoor Unit Dimensions**



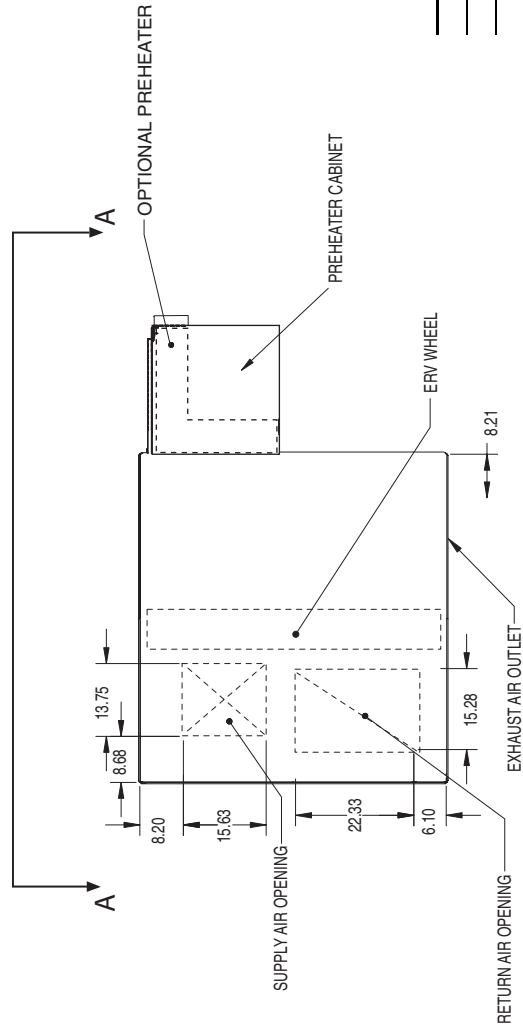


**Fig. 10 — 62MD, ME075, 120 Outdoor Unit Dimensions**



VIEW A-A

RIGHT SIDE



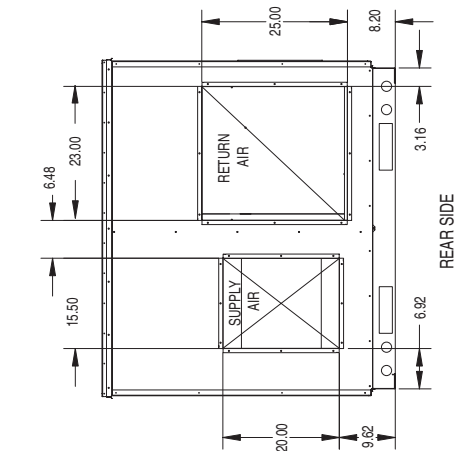
TOP SIDE

**REQUIRED SERVICE CLEARANCES**

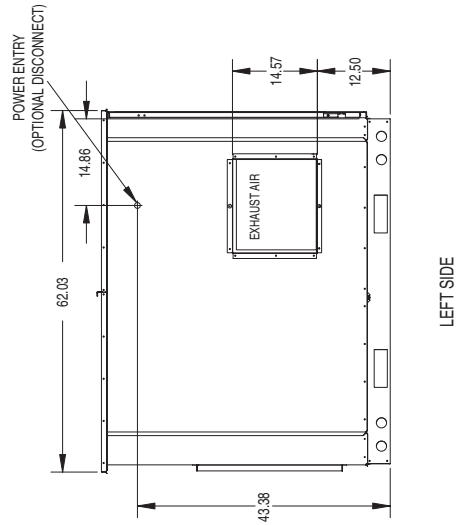
<b>Front</b>	39 in.
<b>Rear</b>	0 in.
<b>Left</b>	32 in.
<b>Right*</b>	55 in.

\*55 in. service clearance required for ERV wheel removal.

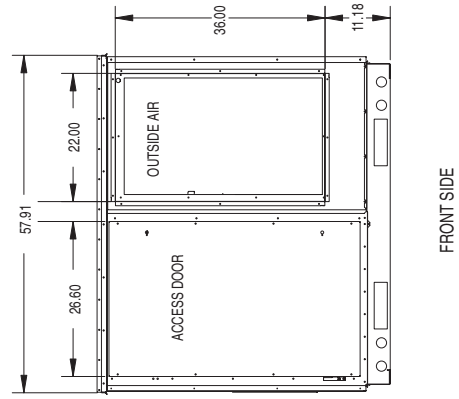
NOTE: All dimensions are in inches.



REAR SIDE

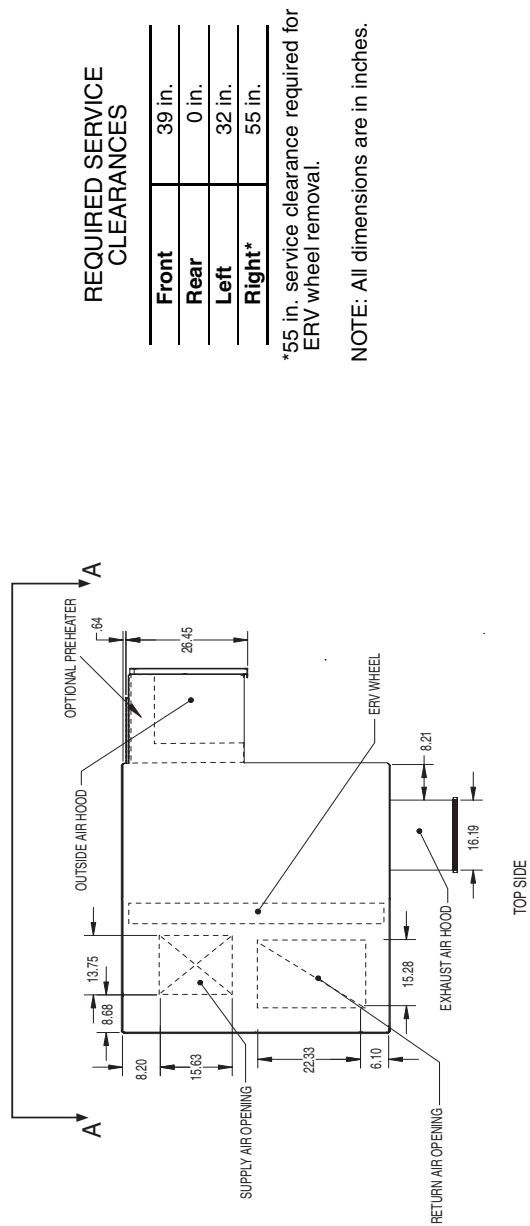


LEFT SIDE



FRONT SIDE

**Fig. 11 — 62MB, MC170-285 Indoor Unit Dimensions**

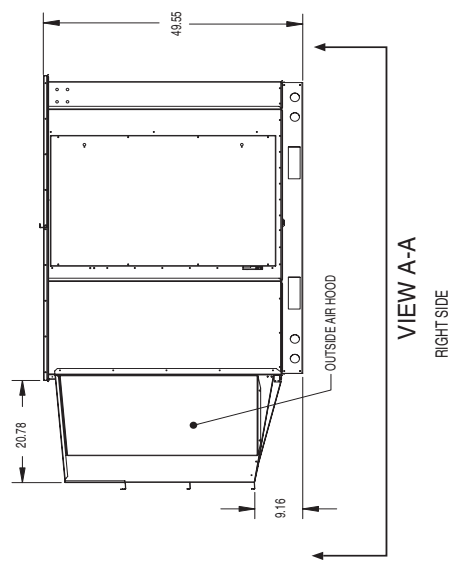


**REQUIRED SERVICE CLEARANCES**

<b>Front</b>	39 in.
<b>Rear</b>	0 in.
<b>Left</b>	32 in.
<b>Right*</b>	55 in.

\*55 in. service clearance required for ERV wheel removal.

NOTE: All dimensions are in inches.



TOP SIDE

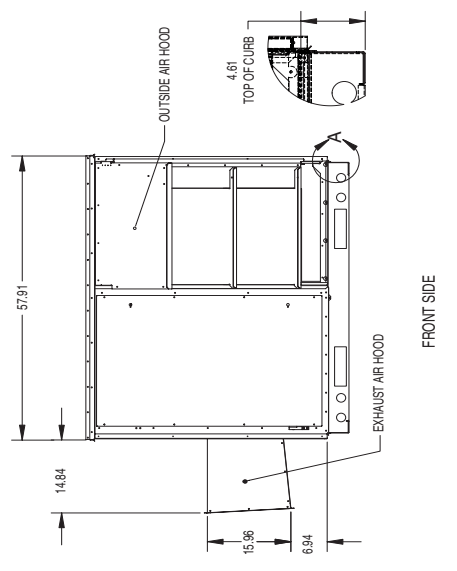
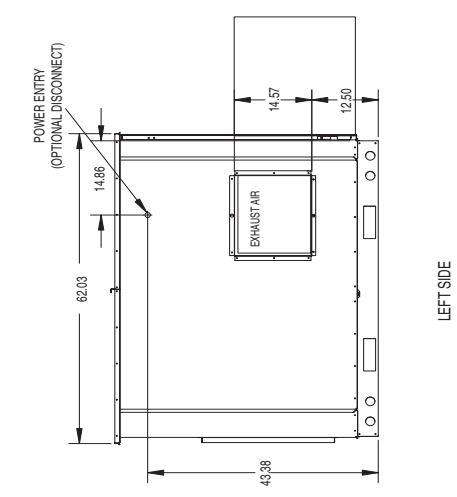
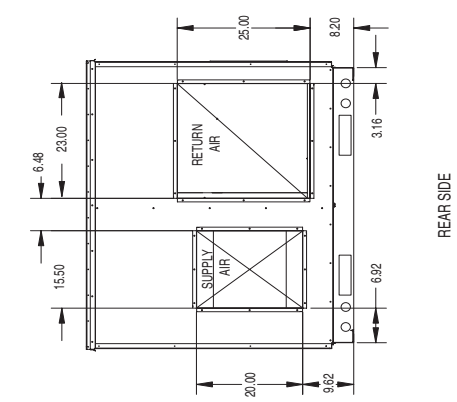
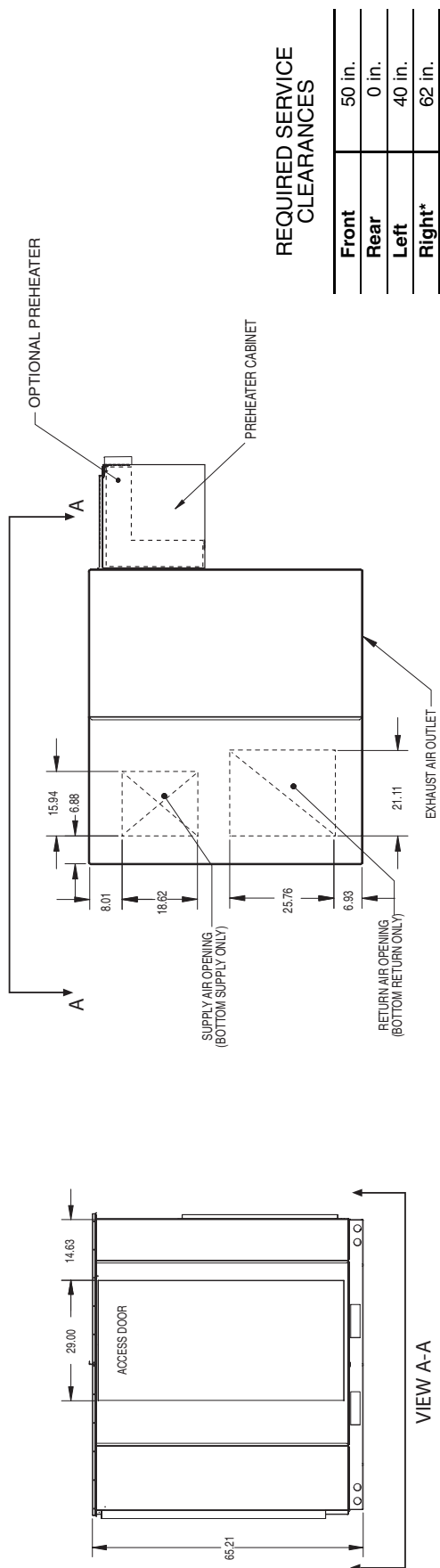


Fig. 12 — 62MD, ME170-285 Outdoor Unit Dimensions



**REQUIRED SERVICE CLEARANCES**

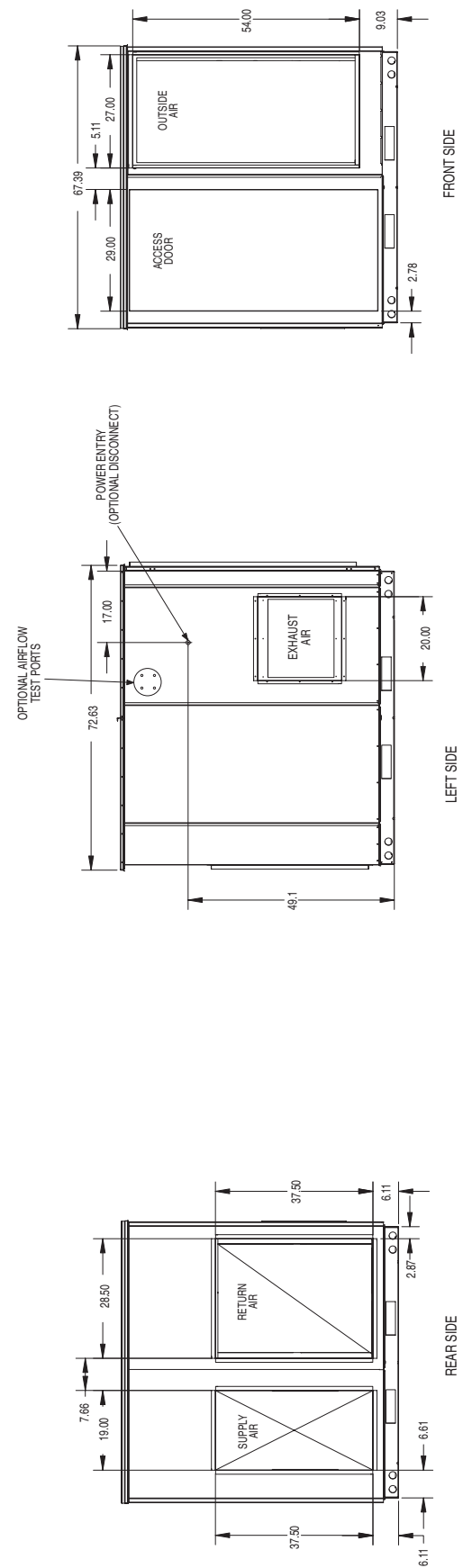
<b>Front</b>	50 in.
<b>Rear</b>	0 in.
<b>Left</b>	40 in.
<b>Right*</b>	62 in.

\*62 in. service clearance required for ERV wheel removal.

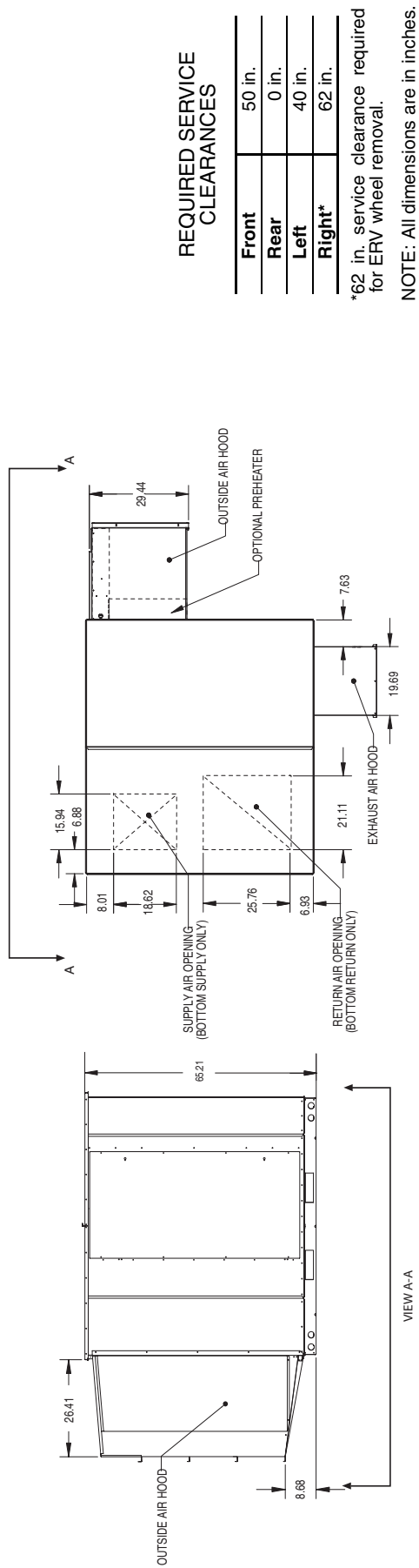
NOTE: All dimensions are in inches.

TOP SIDE

RIGHT SIDE



**Fig. 13 — 62MB, MC330-640 Indoor Unit Dimensions**

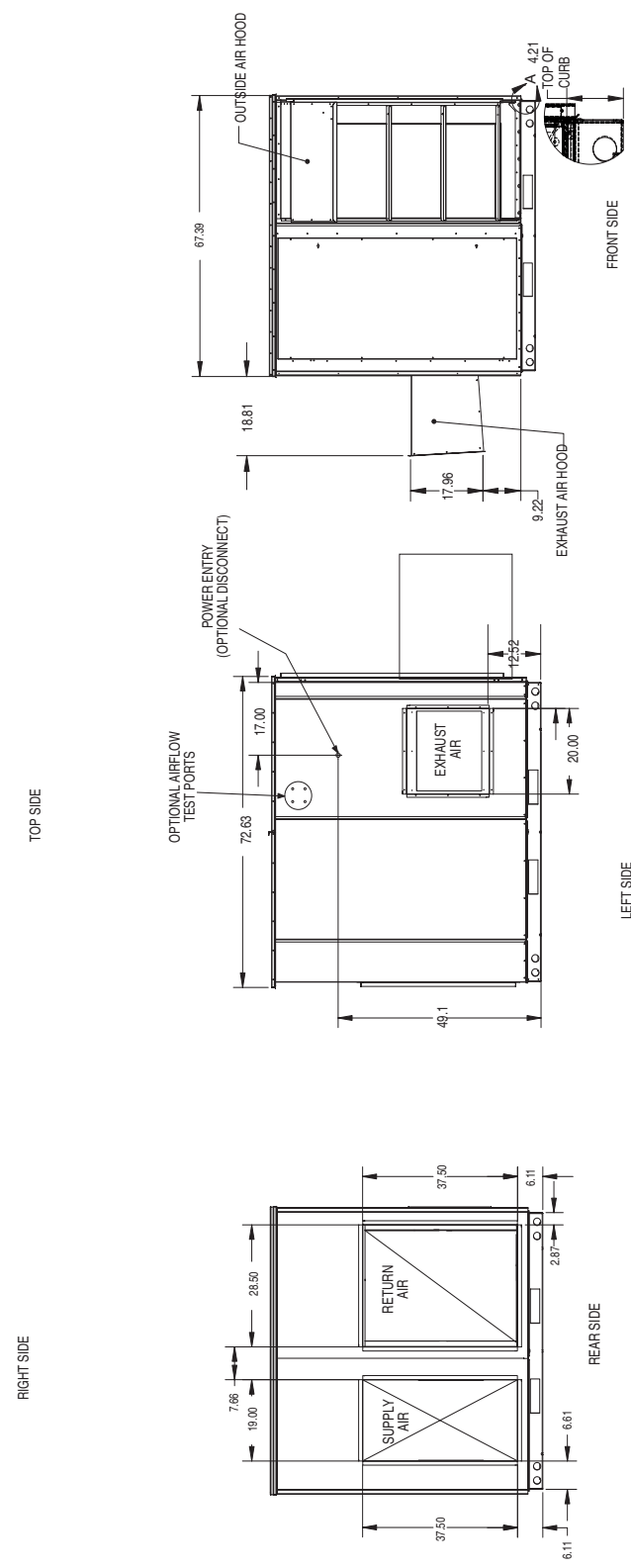


**REQUIRED SERVICE CLEARANCES**

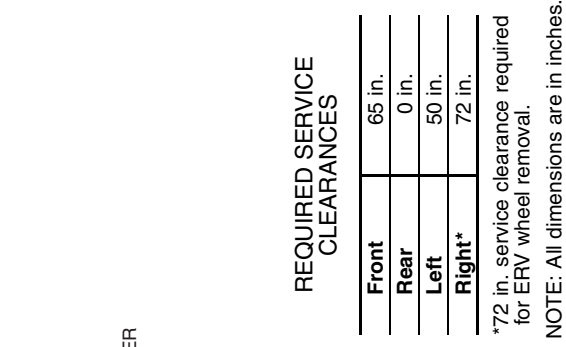
<b>Front</b>	50 in.
<b>Rear</b>	0 in.
<b>Left</b>	40 in.
<b>Right*</b>	62 in.

\*62 in. service clearance required for ERV wheel removal.

NOTE: All dimensions are in inches.



**Fig. 14 — 62MD, ME330-640 Outdoor Unit Dimensions**

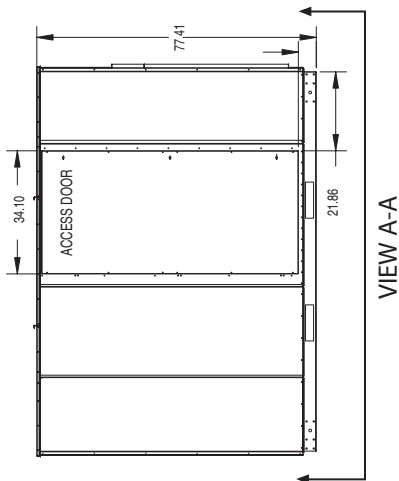


**REQUIRED SERVICE CLEARANCES**

<b>Front</b>	65 in.
<b>Rear</b>	0 in.
<b>Left</b>	50 in.
<b>Right*</b>	72 in.

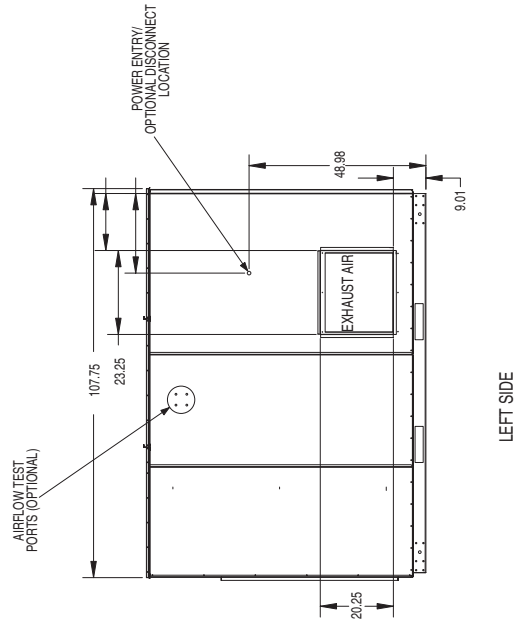
\*72 in. service clearance required for ERV wheel removal.

NOTE: All dimensions are in inches.

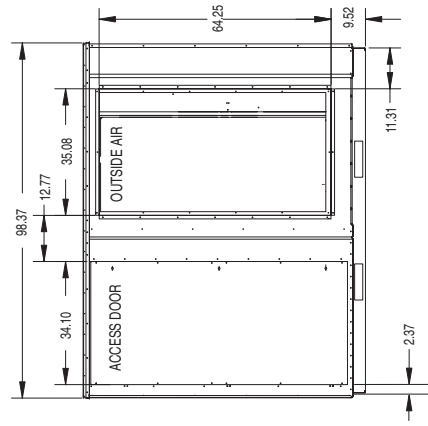


RIGHT SIDE

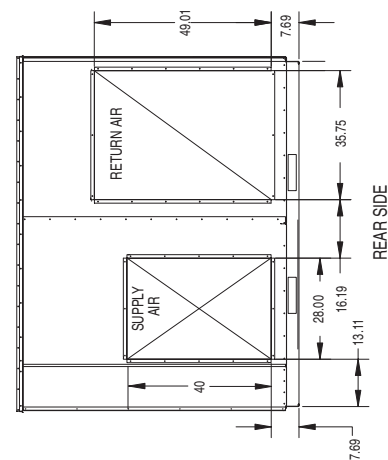
TOP SIDE



LEFT SIDE

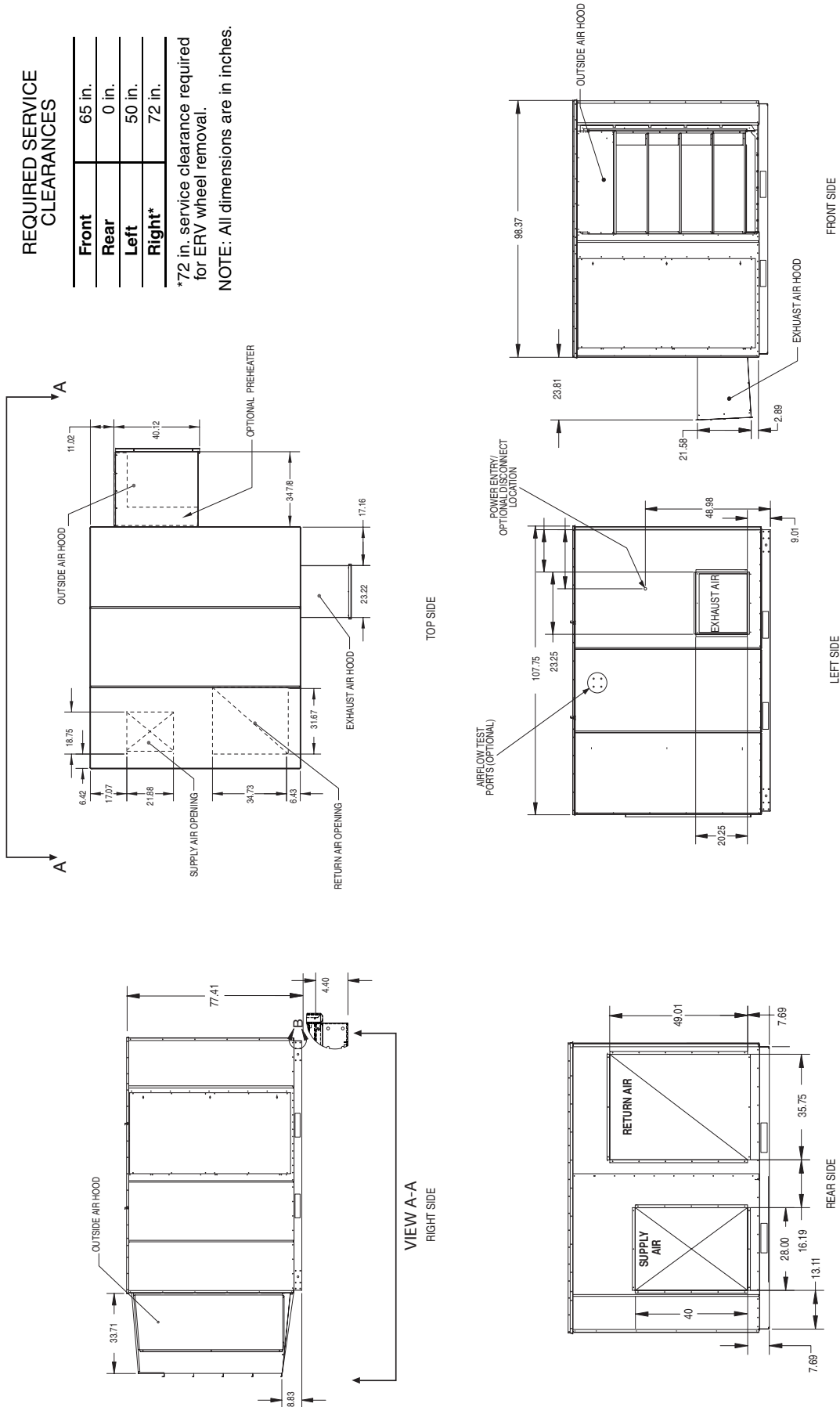


FRONT SIDE



REAR SIDE

**Fig. 15 — 62MB, MC750, 950 Indoor Unit Dimensions**

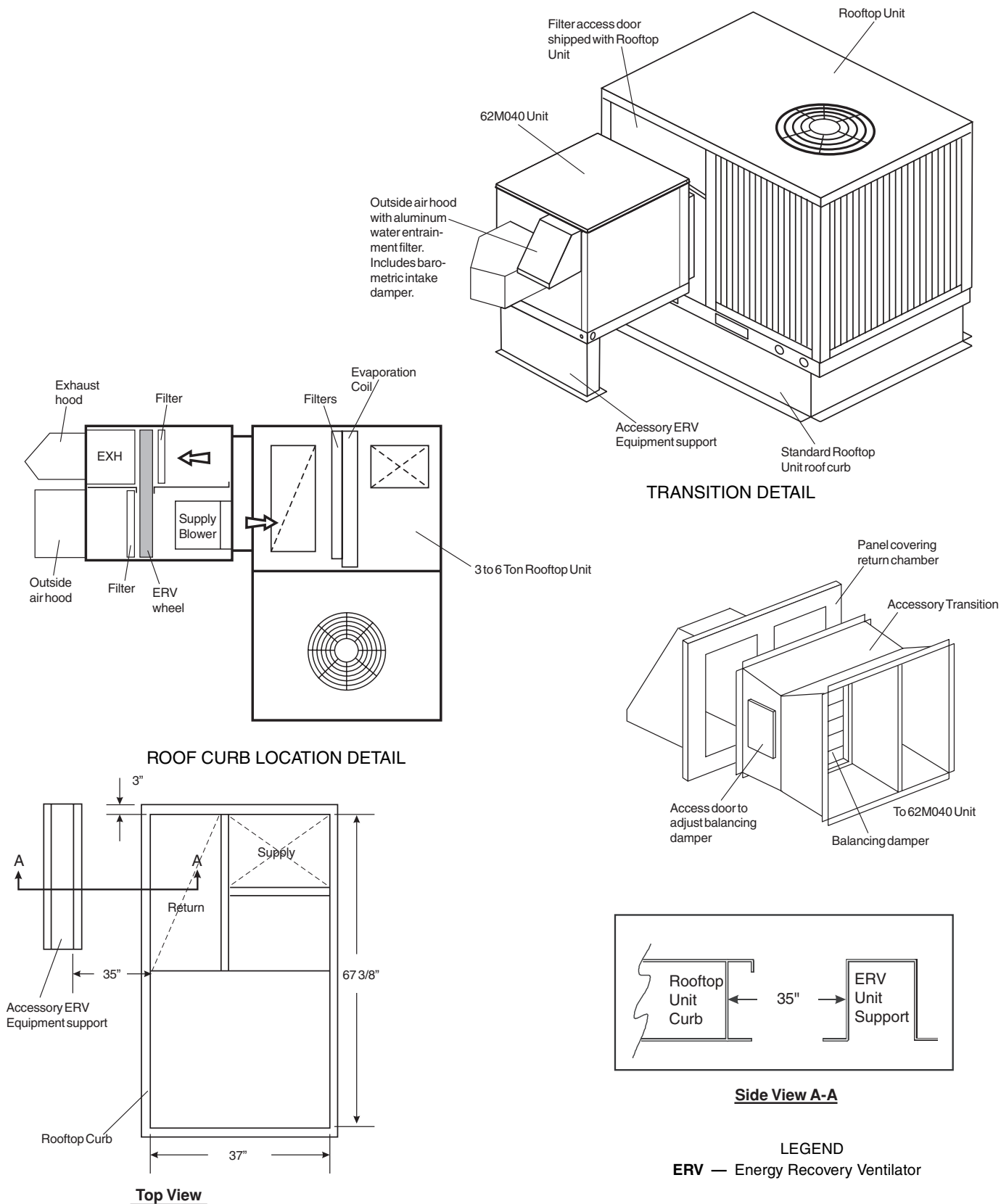


**REQUIRED SERVICE CLEARANCES**

<b>Front</b>	65 in.
<b>Rear</b>	0 in.
<b>Left</b>	50 in.
<b>Right*</b>	72 in.

\*72 in. service clearance required for ERV wheel removal.  
 NOTE: All dimensions are in inches.

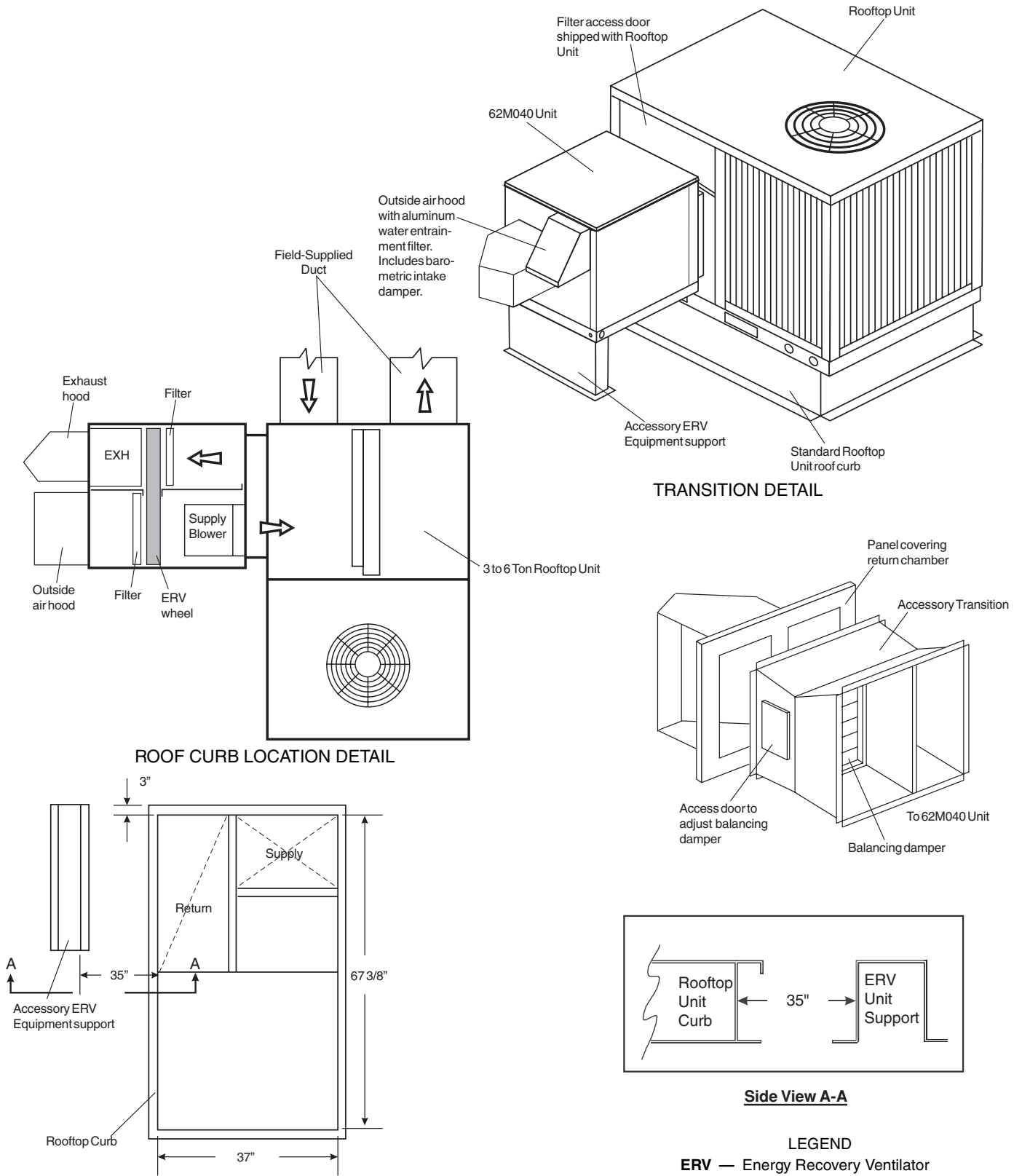
**Fig. 16 — 62MD, ME750,950 Outdoor Unit Dimensions**



ROOFTOP UNIT MODEL	ROOFTOP SIZE	TRANSITION P/N	ROOFTOP ECONOMIZER	ERV EQUIPMENT SUPPORT P/N
48/50HJ,TJ,TM	004-007	62M-AATR-HJ36-D	62MA-900---004	62MA-900---001

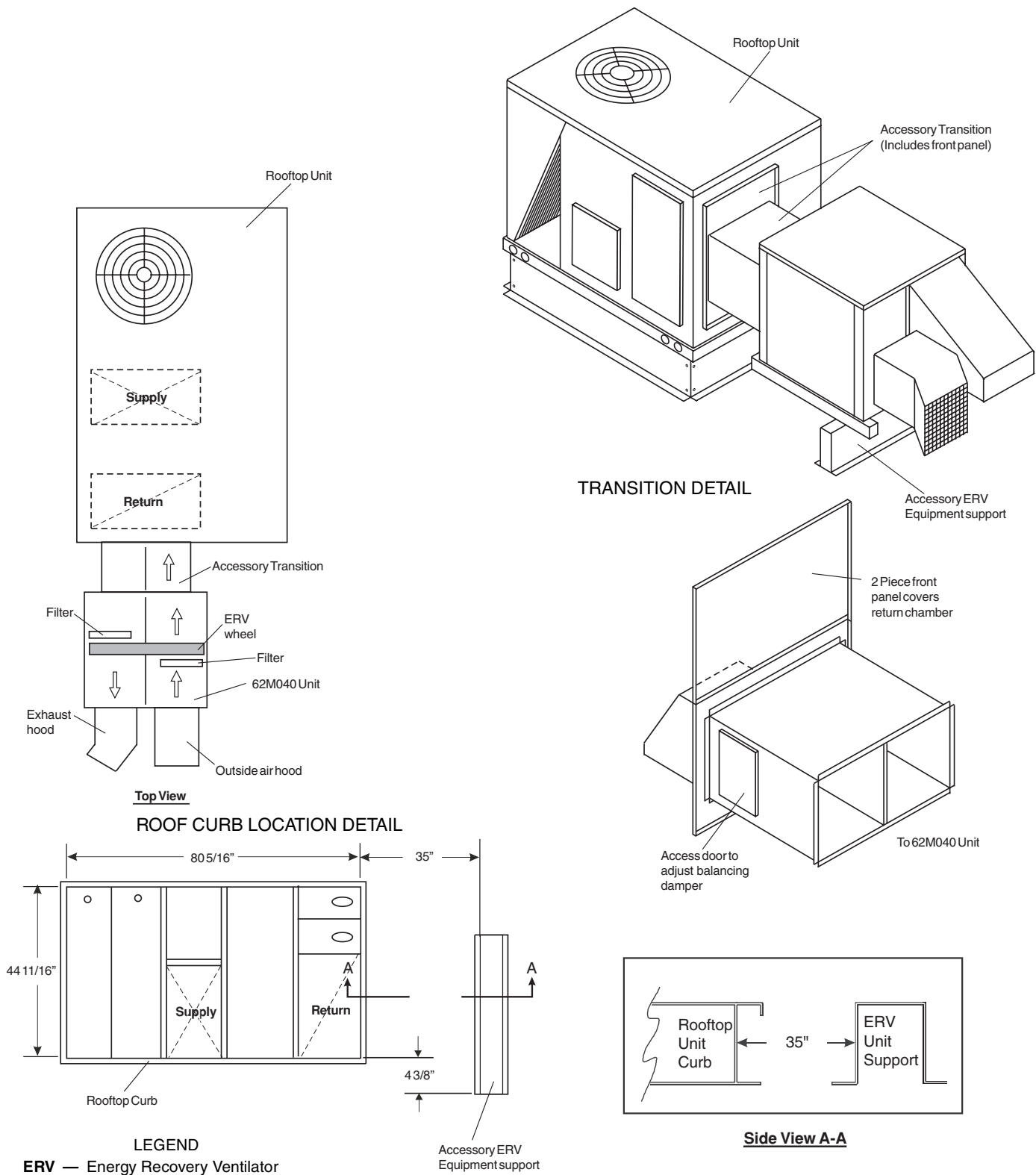
**Fig. 17 — 62MD,ME040 Coupled with Carrier 48/50HJ,TJ,TM004-007 Vertical Discharge Rooftop Unit**





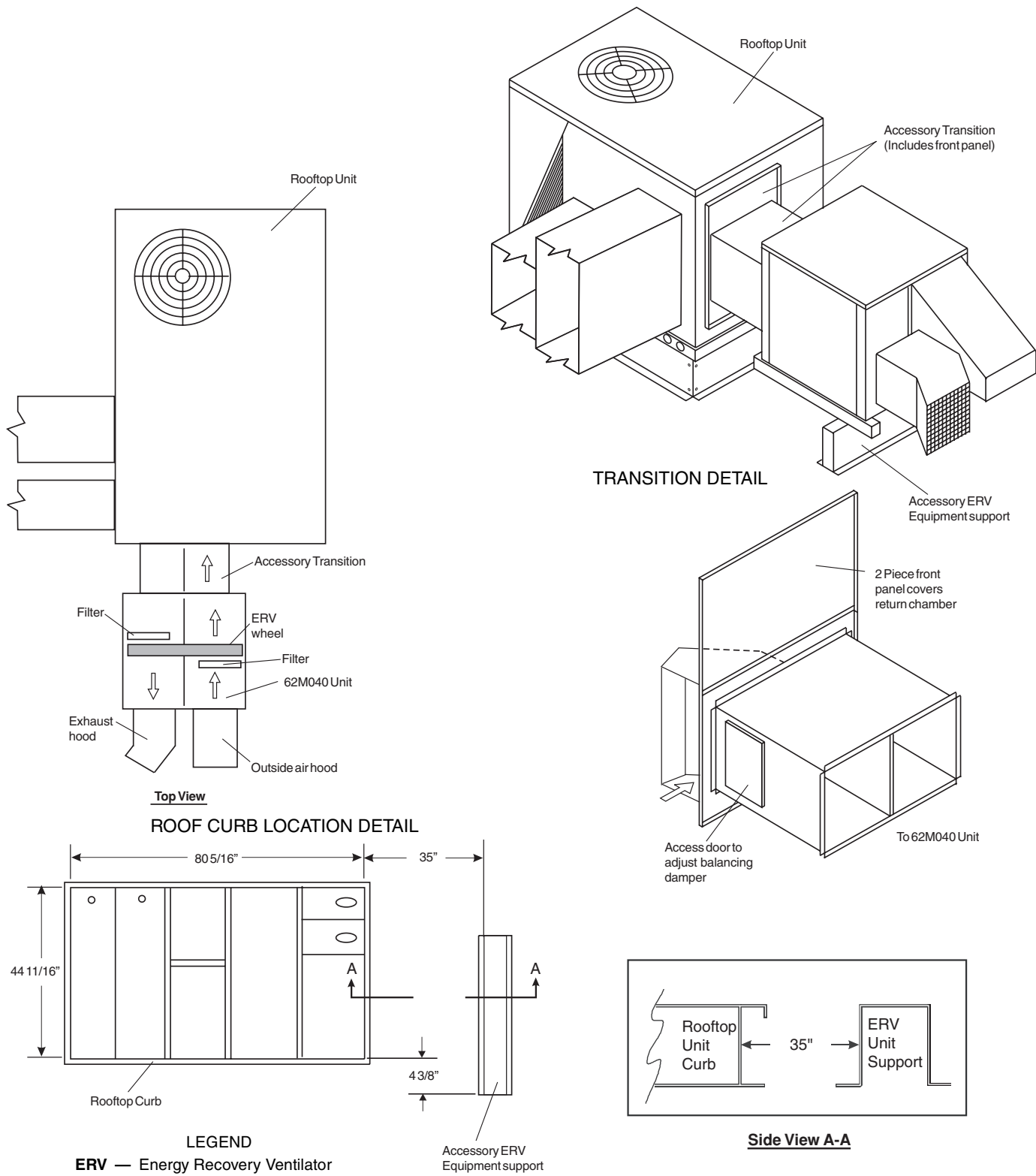
ROOFTOP UNIT MODEL	ROOFTOP SIZE	TRANSITION P/N	ROOFTOP ECONOMIZER	ERV EQUIPMENT SUPPORT P/N
48/50HJ,TJ,TM	004-007	62M-AATR-HJ36-D	62MA-900--008	62MA-900--001

**Fig. 18 — 62MD,ME040 Coupled with Carrier 48/50HJ,TJ,TM004-007 Horizontal Discharge Rooftop Unit**



**Fig. 19 — 62MD,ME040 Coupled with Carrier 48/50PG03-07 Vertical Discharge Rooftop Unit**

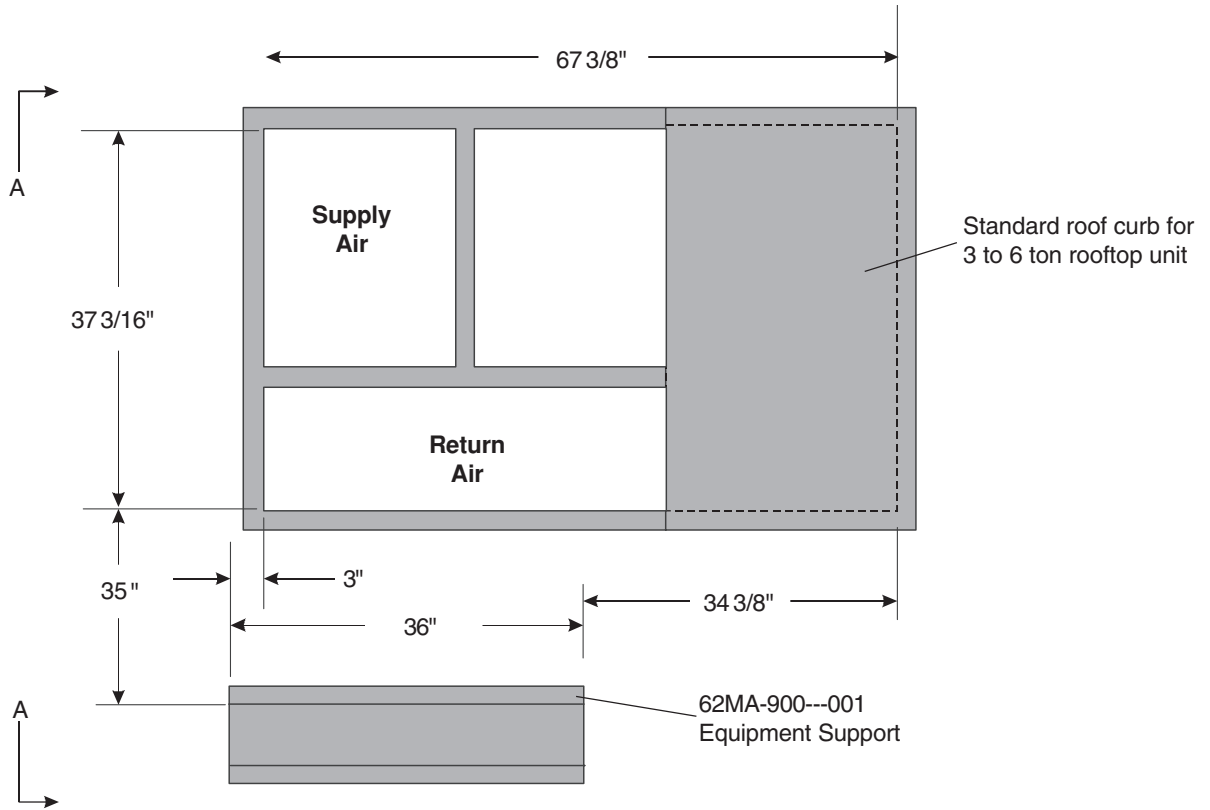
ROOFTOP UNIT MODEL	ROOFTOP SIZE	TRANSITION P/N	ERV EQUIPMENT SUPPORT P/N
48/50PG	03-07	62M-AATR-HJ36-D	62MA-900--001



ROOFTOP UNIT MODEL	ROOFTOP SIZE	TRANSITION P/N	ERV EQUIPMENT SUPPORT P/N
48/50PG	03-07	62M-AATR-HJ36-D	62MA-900---001

**Fig. 20 — 62MD,ME040 Coupled with Carrier 48/50PG03-07 Horizontal Discharge Rooftop Unit**

ROOF CURB LAYOUT  
TOP VIEW



"A-A" SIDE VIEW

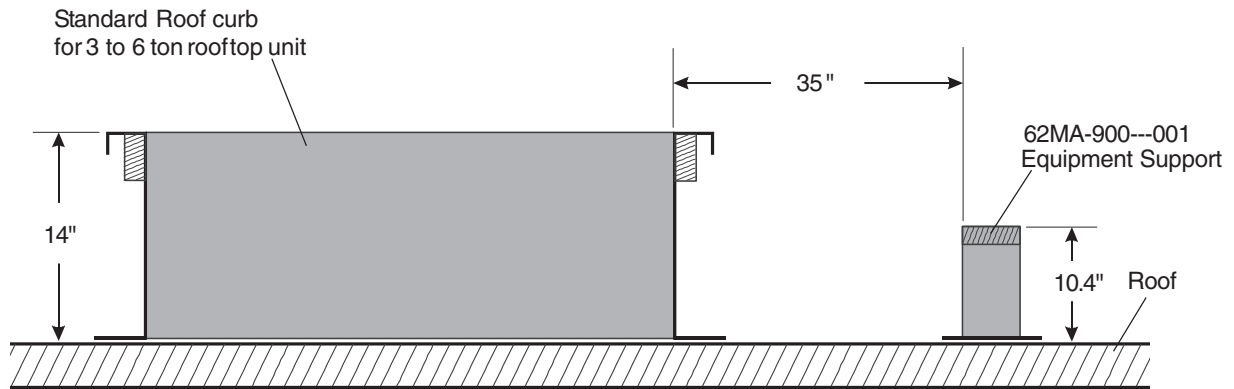
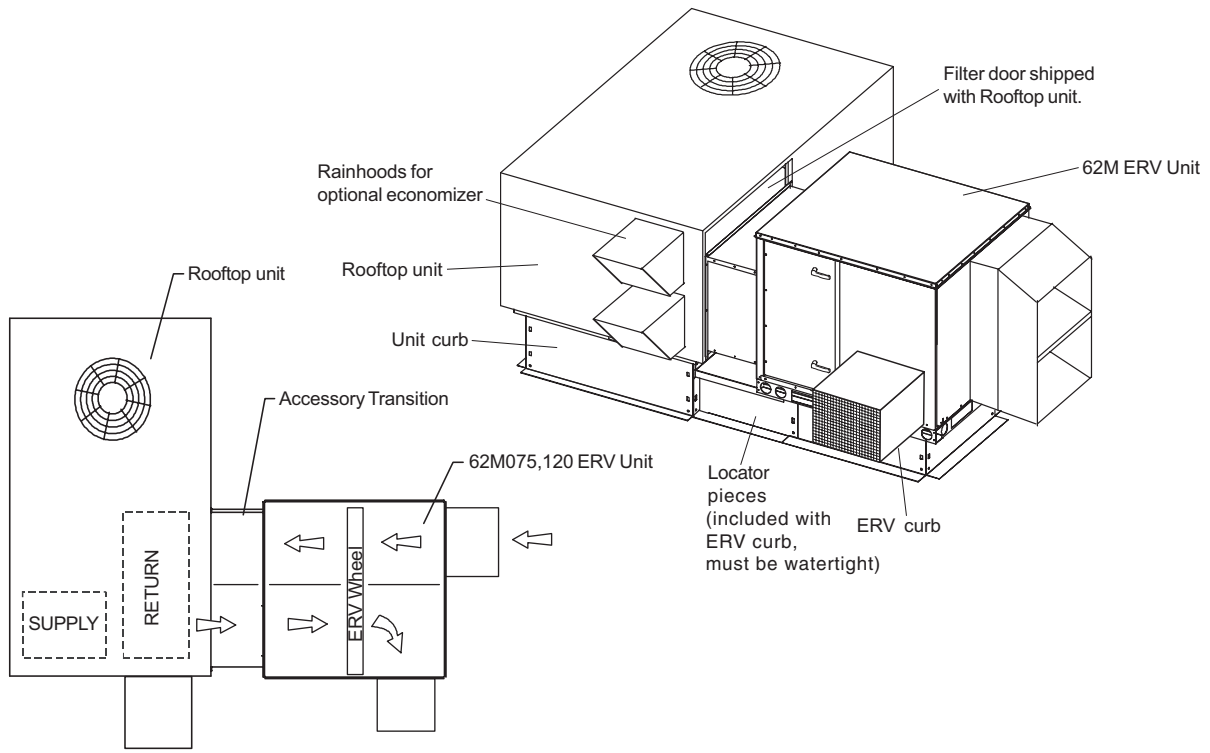
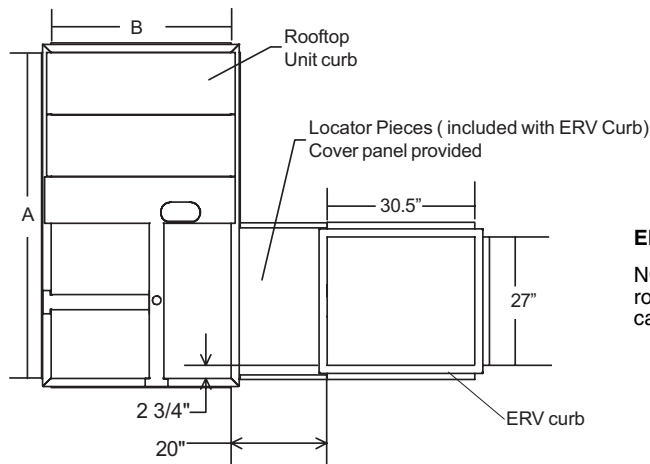


Fig. 21 — 62MD,ME040 Coupled with Carrier 48/50HJ,TJ,TM004-007 Rooftop Unit



ROOF CURB LOCATION DETAIL

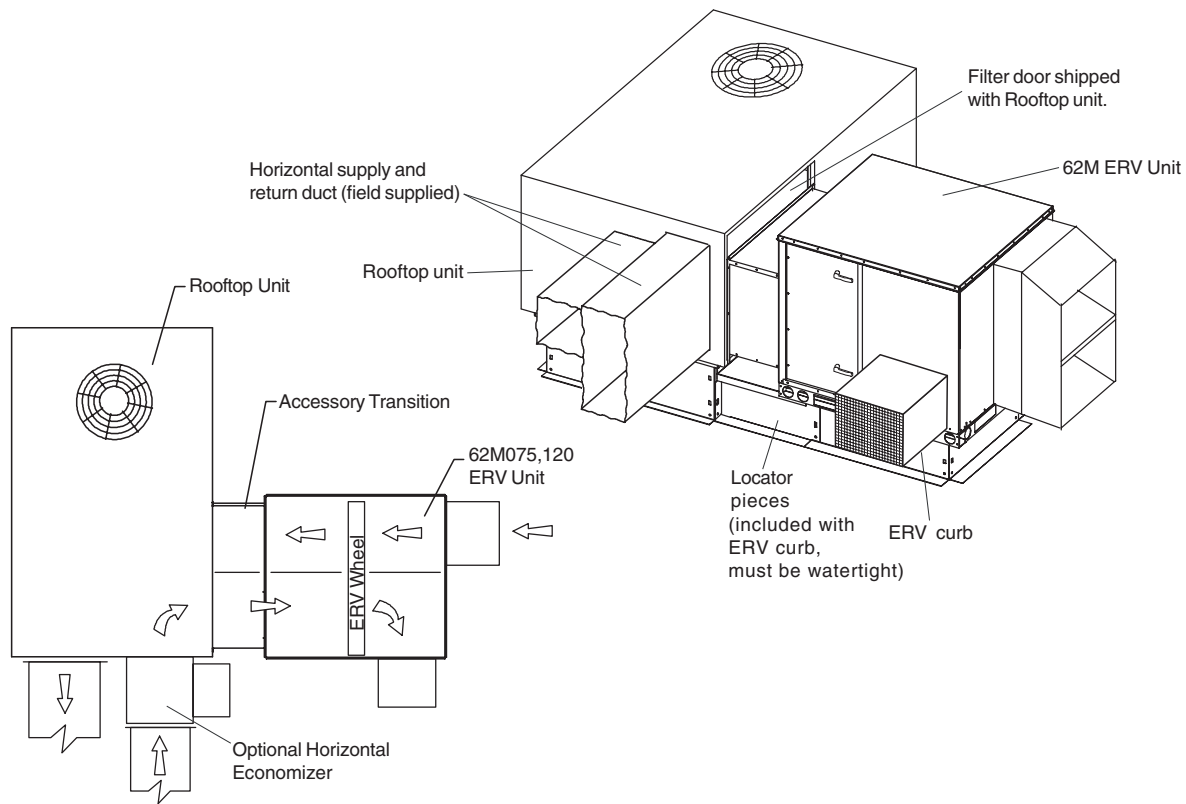


LEGEND  
**ERV** — Energy Recovery Ventilator

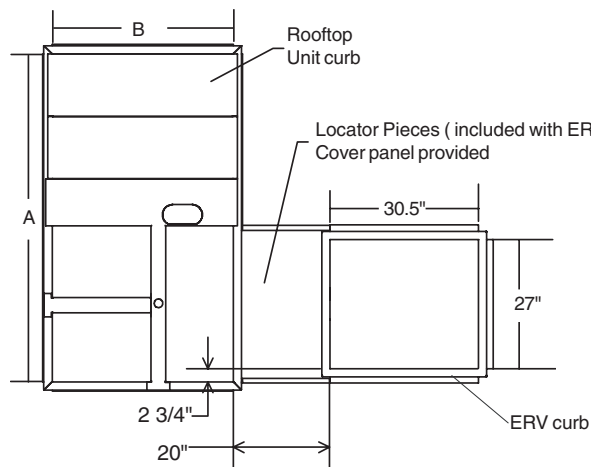
NOTE: When using a 62M ERV unit coupled with a Carrier rooftop unit, the rooftop factory or field-installed economizer cannot be used. Use the 62M economizer instead.

ROOFTOP UNIT MODEL	ROOFTOP SIZE	TRANSITION P/N	ERV CURB P/N	ROOFTOP ECONOMIZER	DIMENSIONS (in.)	
					A	B
48/50HJ,TF,TJ,TM	004-007	62M-ATR-HJ36-D	62M-A-CRB-14MC	62MA-900--004	67 <sup>3</sup> / <sub>8</sub>	37 <sup>3</sup> / <sub>16</sub>
	008,009	62M-ATR-HJ78-D	62M-A-CRB-14MC	62MA-900--005	78 <sup>1</sup> / <sub>4</sub>	50
	012,014	62M-ATR-HJ1012-D	62M-A-CRB-14MC	62MA-900--006	78 <sup>1</sup> / <sub>4</sub>	50

Fig. 22 — 62MD,ME075,120 Coupled with Carrier 48/50HJ,TF,TJ,TM004-014 Vertical Discharge Rooftop Unit



ROOF CURB LOCATION DETAIL



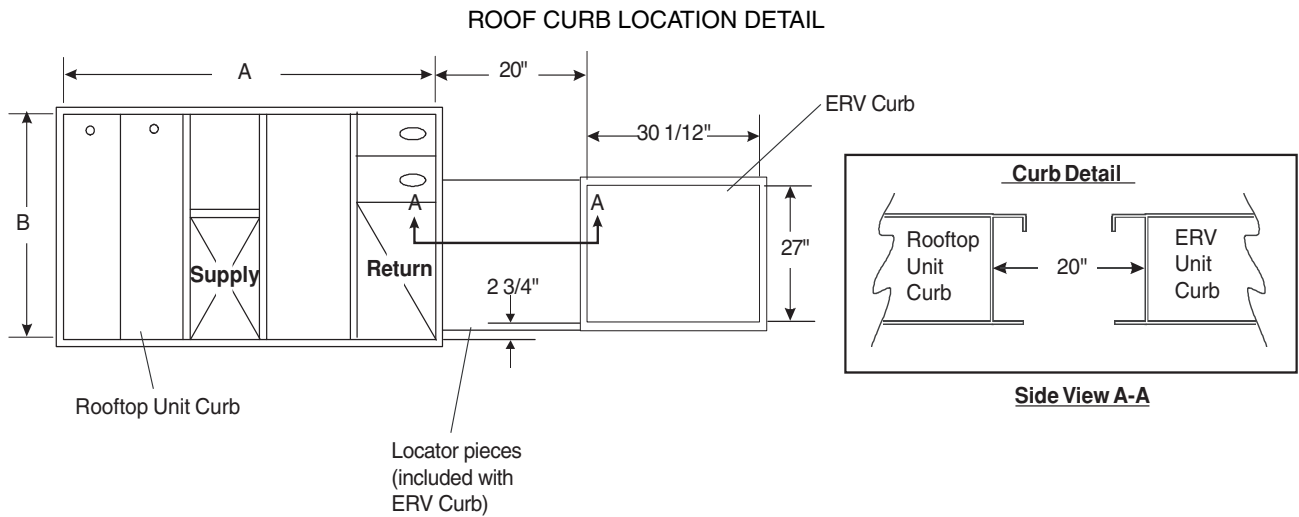
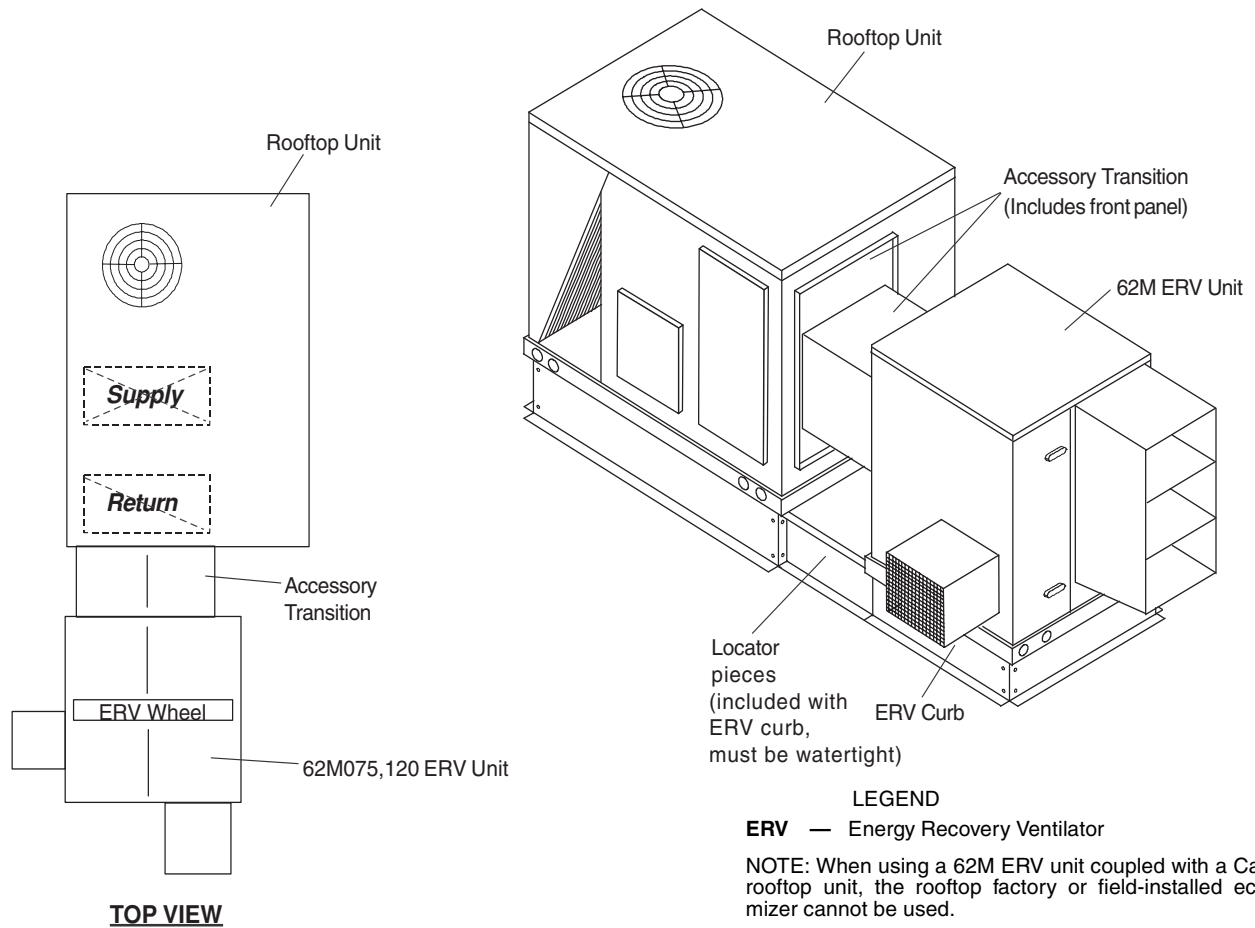
LEGEND

**ERV** — Energy Recovery Ventilator

NOTE: When using a 62M ERV unit coupled with a Carrier rooftop unit, the rooftop factory or field-installed economizer cannot be used. Use the 62M economizer instead.

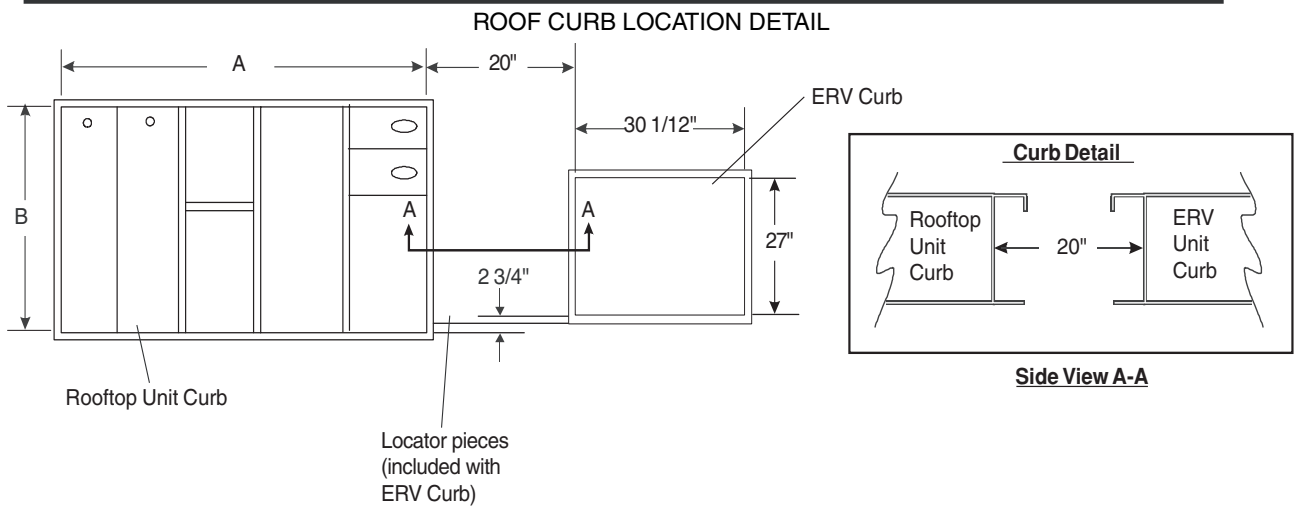
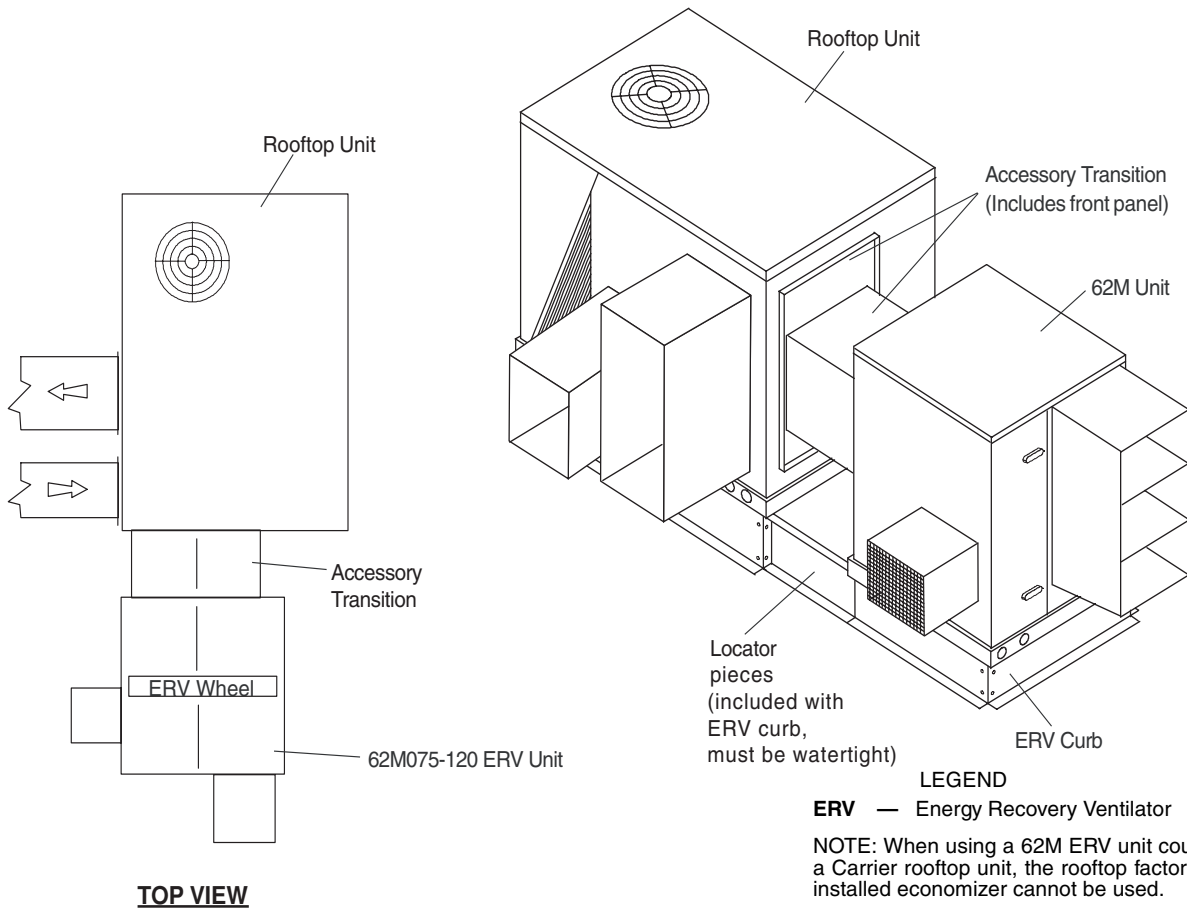
ROOFTOP UNIT MODEL	ROOFTOP SIZE	TRANSITION P/N	ERV CURB P/N	ROOFTOP ECONOMIZER	DIMENSIONS (in.)	
					A	B
48/50HJ,TF,TJ,TM	004,007	62M-ATR-HJ36-H	62M-A-CRB-14MC	62MA-900---008	67 <sup>3</sup> / <sub>8</sub>	37 <sup>3</sup> / <sub>16</sub>
	008,009	62M-ATR-HJ78-H	62M-A-CRB-14MC	62MA-900---009	78 <sup>1</sup> / <sub>4</sub>	50
	012,014	62M-ATR-HJ1012-H	62M-A-CRB-14MC	62MA-900---010	78 <sup>1</sup> / <sub>4</sub>	50

Fig. 23 — 62MD,ME075,120 Coupled with Carrier 48/50HJ,TF,TJ,TM004-014 Horizontal Discharge Rooftop Unit



ROOFTOP MODEL	ROOFTOP SIZE	62M TRANSITION	ERV CURB	DIMENSIONS (in.)	
				A	B
48/50PG	03-07	62M-ATR-PG26-D	62M-A-CRB-14MC	80 <sup>5</sup> / <sub>16</sub>	44 <sup>11</sup> / <sub>16</sub>
	08-14	62M-ATR-PG712-D	62M-A-CRB-14MC	92 <sup>3</sup> / <sub>4</sub>	53 <sup>15</sup> / <sub>16</sub>

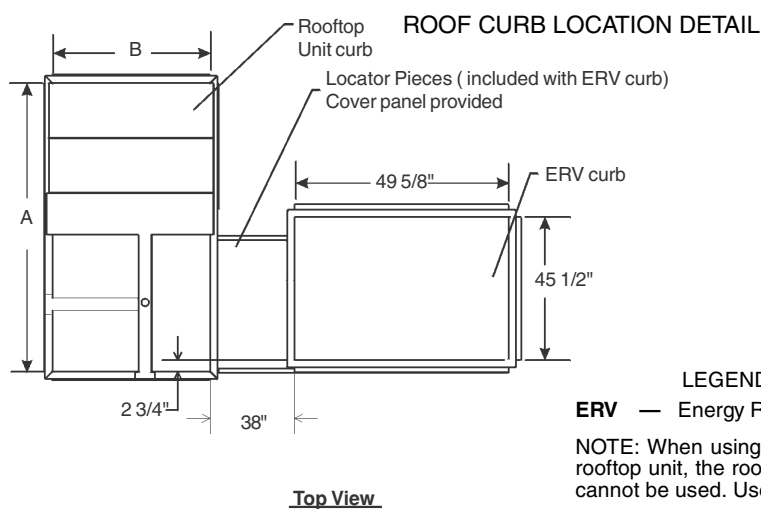
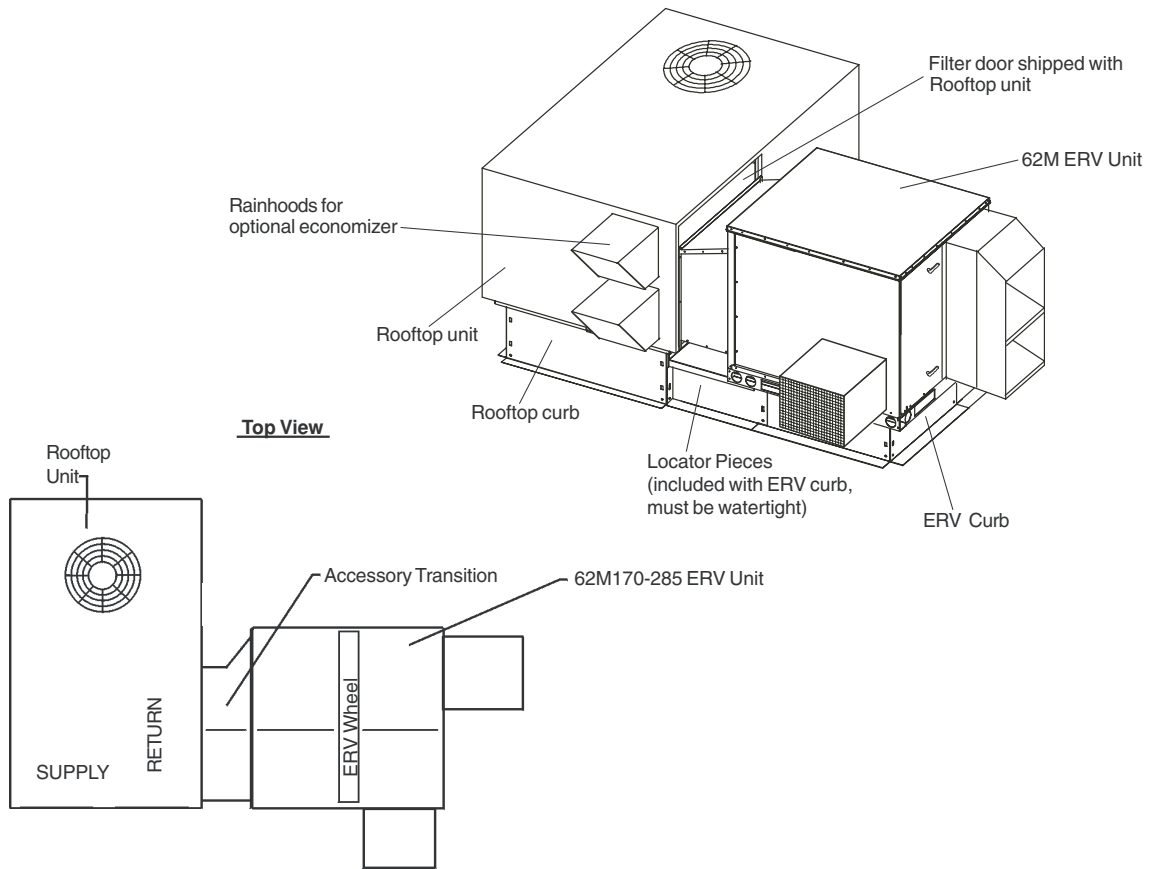
**Fig. 24 — 62MD,ME075,120 Coupled with Carrier 48/50PG03-14 Vertical Discharge Rooftop Unit**



ROOFTOP MODEL	ROOFTOP SIZE	62M TRANSITION	ERV CURB	DIMENSIONS (in.)	
				A	B
48/50PG	03-07	62M-ATR-PG26-H	62M-A-CRB-14MC	80 <sup>5</sup> / <sub>16</sub>	44 <sup>11</sup> / <sub>16</sub>
	08-14	62M-ATR-PG712-H	62M-A-CRB-14MC	92 <sup>3</sup> / <sub>4</sub>	53 <sup>15</sup> / <sub>16</sub>

**Fig. 25 — 62MD,ME075,120 Coupled with Carrier 48/50PG03-14 Horizontal Discharge Rooftop Unit**





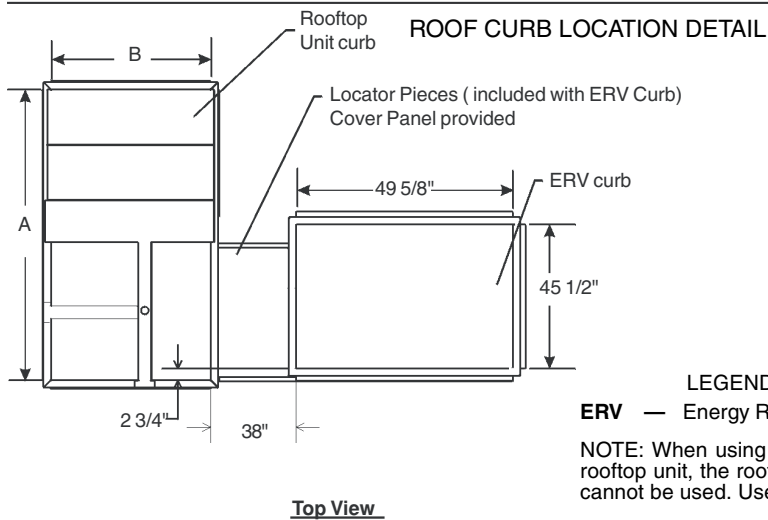
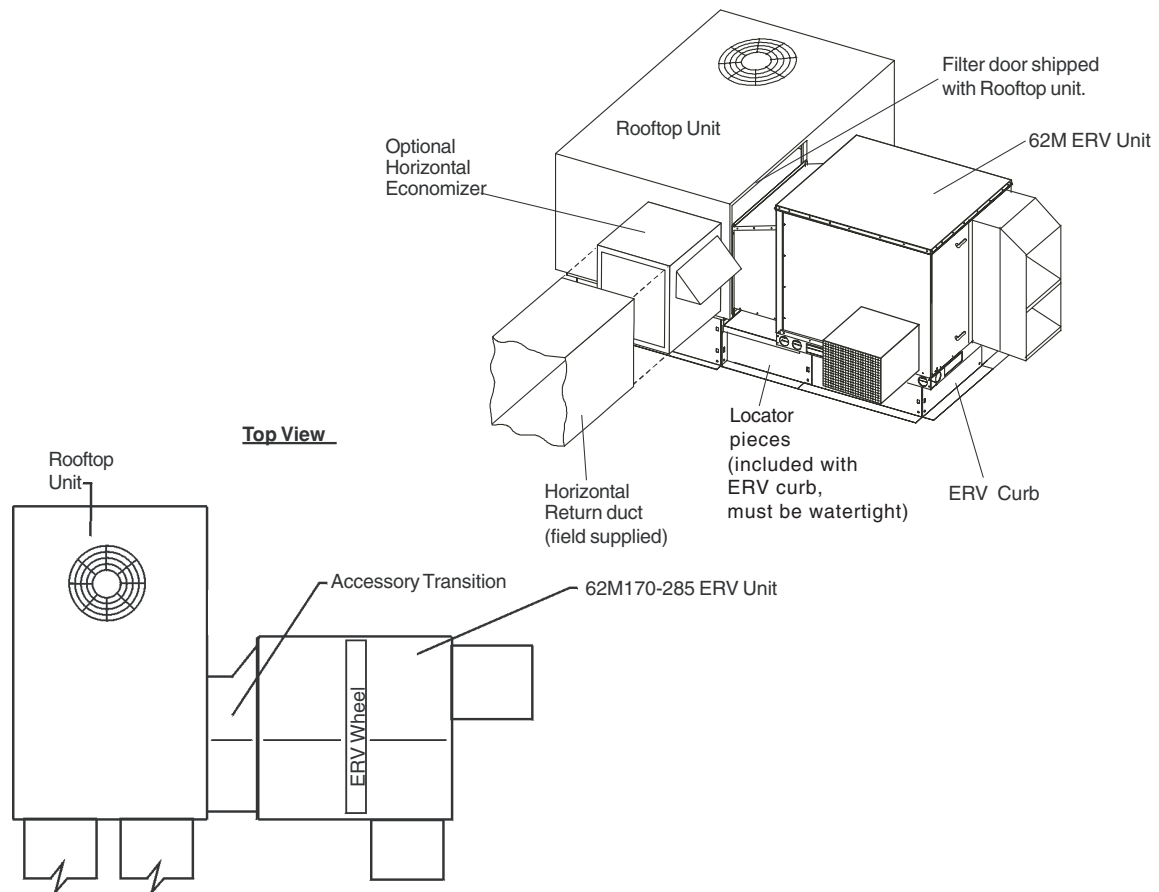
**LEGEND**

**ERV** — Energy Recovery Ventilator

**NOTE:** When using a 62M ERV unit coupled with a Carrier rooftop unit, the rooftop factory or field-installed economizer cannot be used. Use the 62M economizer instead.

ROOFTOP UNIT MODEL	ROOFTOP SIZE	TRANSITION P/N	ERV CURB P/N	ROOFTOP ECONOMIZER	DIMENSIONS (in.)	
					A	B
48/50HJ,TF,TJ,TM	004-007	62M-BTR-HJ36-D	62M-B-CRB-14MC	62MA-900---004	67 <sup>3</sup> / <sub>8</sub>	37 <sup>3</sup> / <sub>16</sub>
	008,009	62M-BTR-HJ78-D	62M-B-CRB-14MC	62MA-900---005	78 <sup>1</sup> / <sub>4</sub>	50
	012,014	62M-BTR-HJ1012-D	62M-B-CRB-14MC	62MA-900---006	78 <sup>1</sup> / <sub>4</sub>	50

**Fig. 26 — 62MD,ME170-285 Coupled with Carrier 48/50HJ,TF,TJ,TM004-014 Vertical Discharge Rooftop Unit**



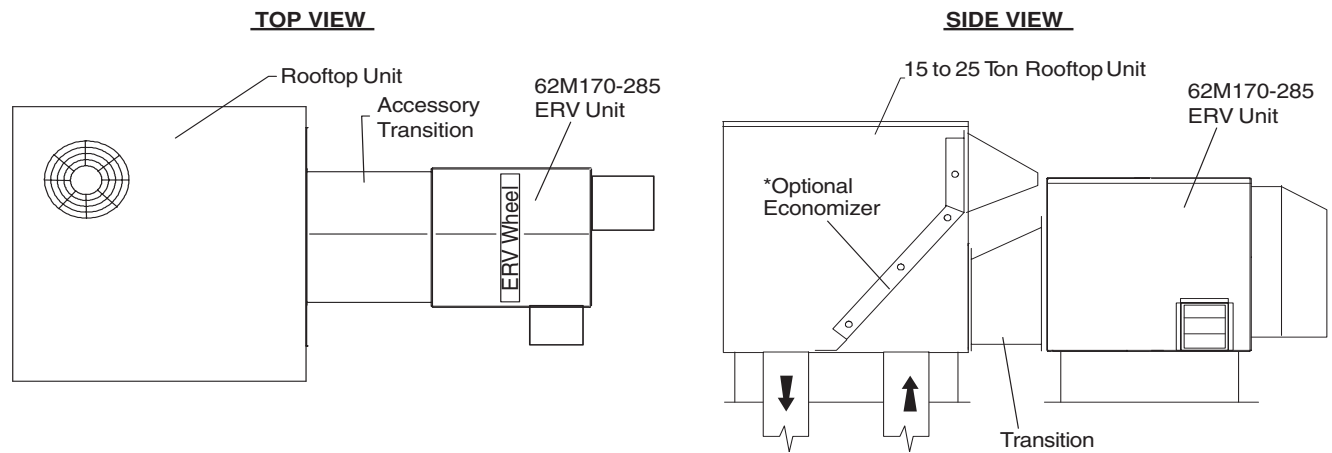
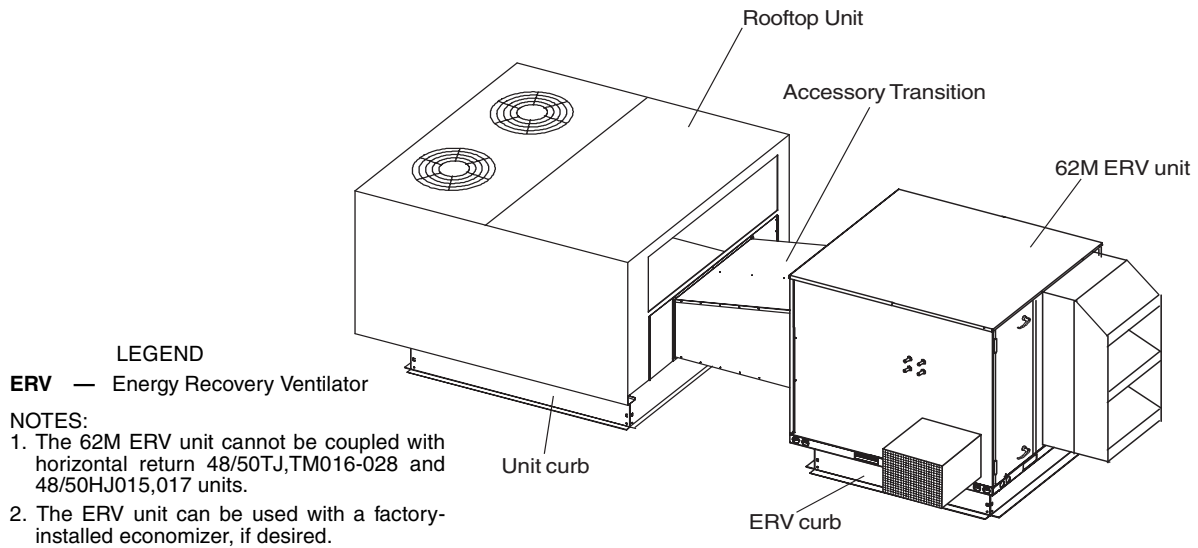
**LEGEND**

**ERV** — Energy Recovery Ventilator

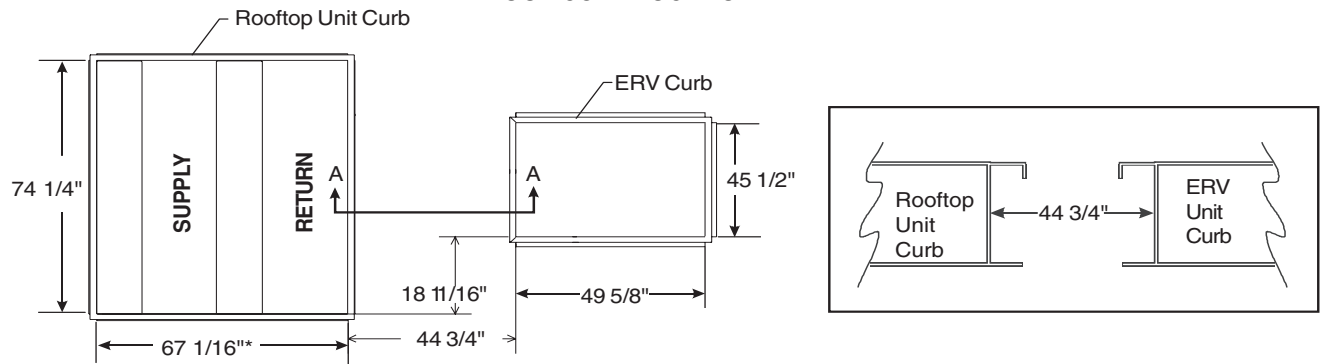
NOTE: When using a 62M ERV unit coupled with a Carrier rooftop unit, the rooftop factory or field-installed economizer cannot be used. Use the 62M economizer instead.

ROOFTOP UNIT MODEL	ROOFTOP SIZE	TRANSITION P/N	ERV CURB P/N	ROOFTOP ECONOMIZER	DIMENSIONS (in.)	
					A	B
48/50HJ,TF,TJ,TM	004-007	62M-BTR-HJ36-H	62M-B-CRB-14MC	62MA-900---008	67 <sup>3</sup> / <sub>8</sub>	37 <sup>3</sup> / <sub>16</sub>
	008,009	62M-BTR-HJ78-H	62M-B-CRB-14MC	62MA-900---009	78 <sup>1</sup> / <sub>4</sub>	50
	012,014	62M-BTR-HJ1012-H	62M-B-CRB-14MC	62MA-900---010	78 <sup>1</sup> / <sub>4</sub>	50

**Fig. 27 — 62MD,ME170-285 Coupled with Carrier 48/50HJ,TF,TJ,TM004-014 Horizontal Discharge Rooftop Unit**



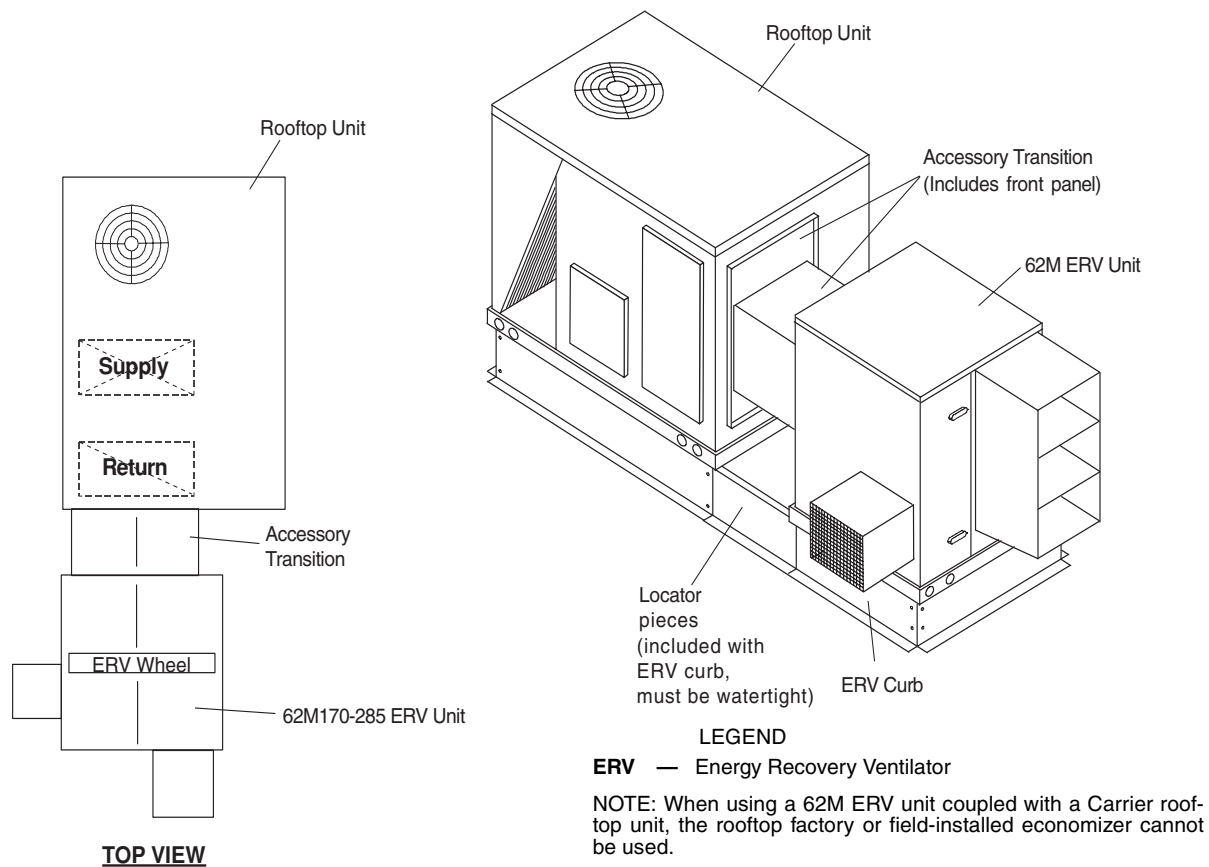
**ROOF CURB LOCATION DETAIL**



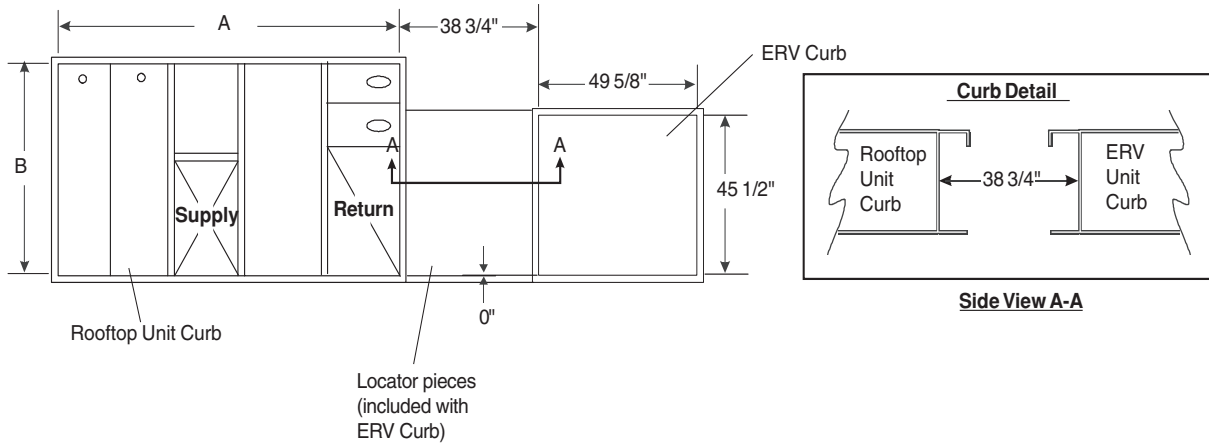
\*Length is 89<sup>1</sup>/<sub>16</sub>" for 48/50TM028 units.

ROOFTOP UNIT MODEL	ROOFTOP SIZE	TRANSITION P/N	ERV CURB P/N
48/50TJ, TM	016-028	62M-BTR-HJ1525-D	62M-B-CRB-14S
48/50HJ	015,017	62M-BTR-HJ1525-D	62M-B-CRB-14S

**Fig. 28 — 62MD, ME170-285 Coupled with Carrier 48/50TJ, TM016-028 and 48/50HJ015,017 Vertical Discharge Rooftop Unit**

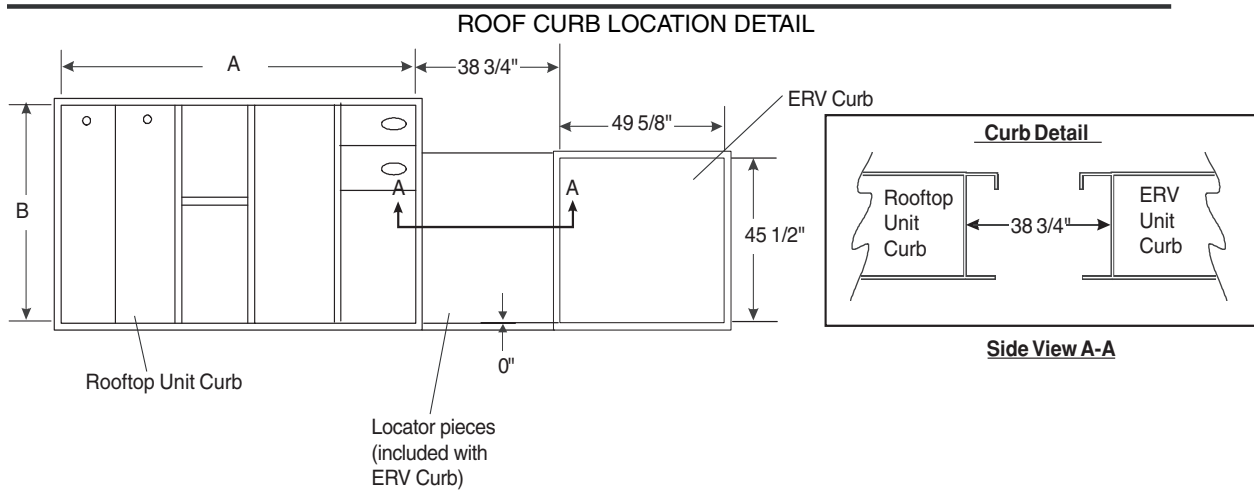
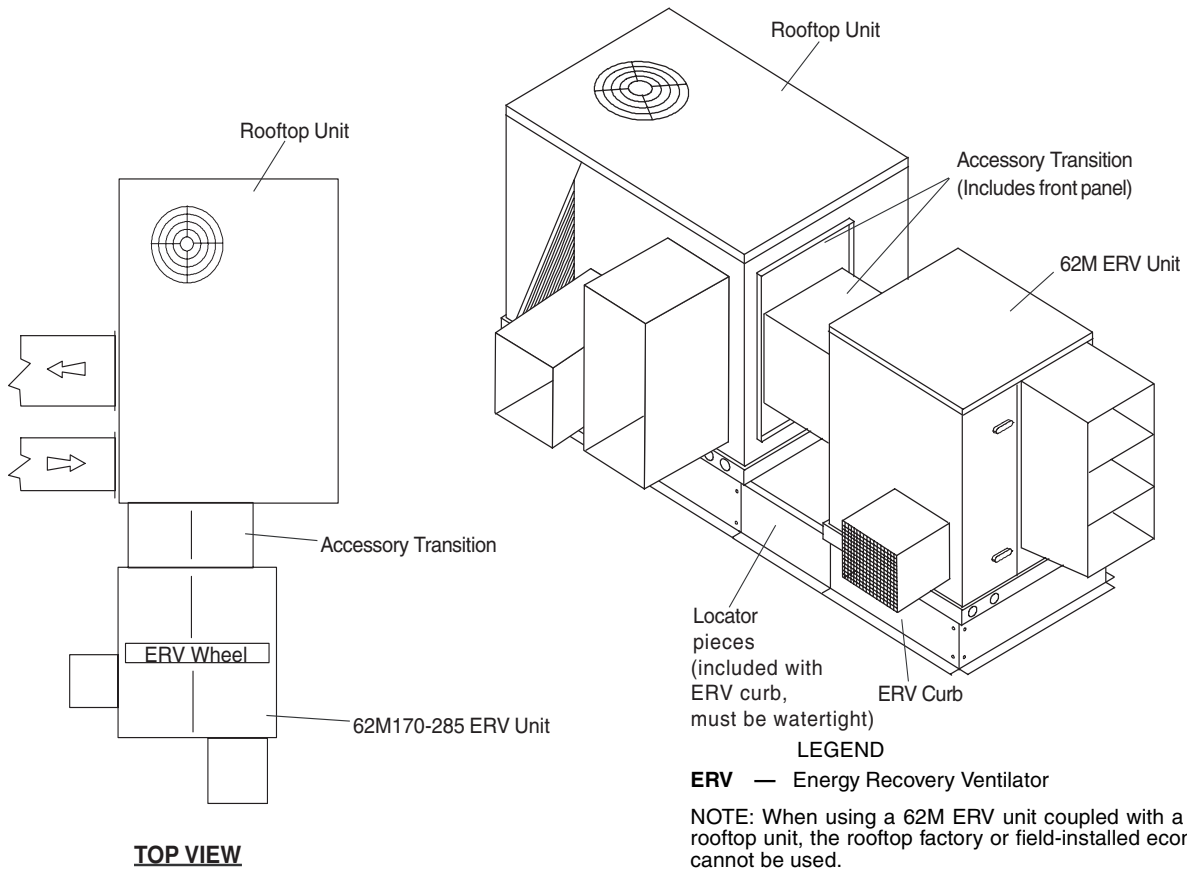


**ROOF CURB LOCATION DETAIL**



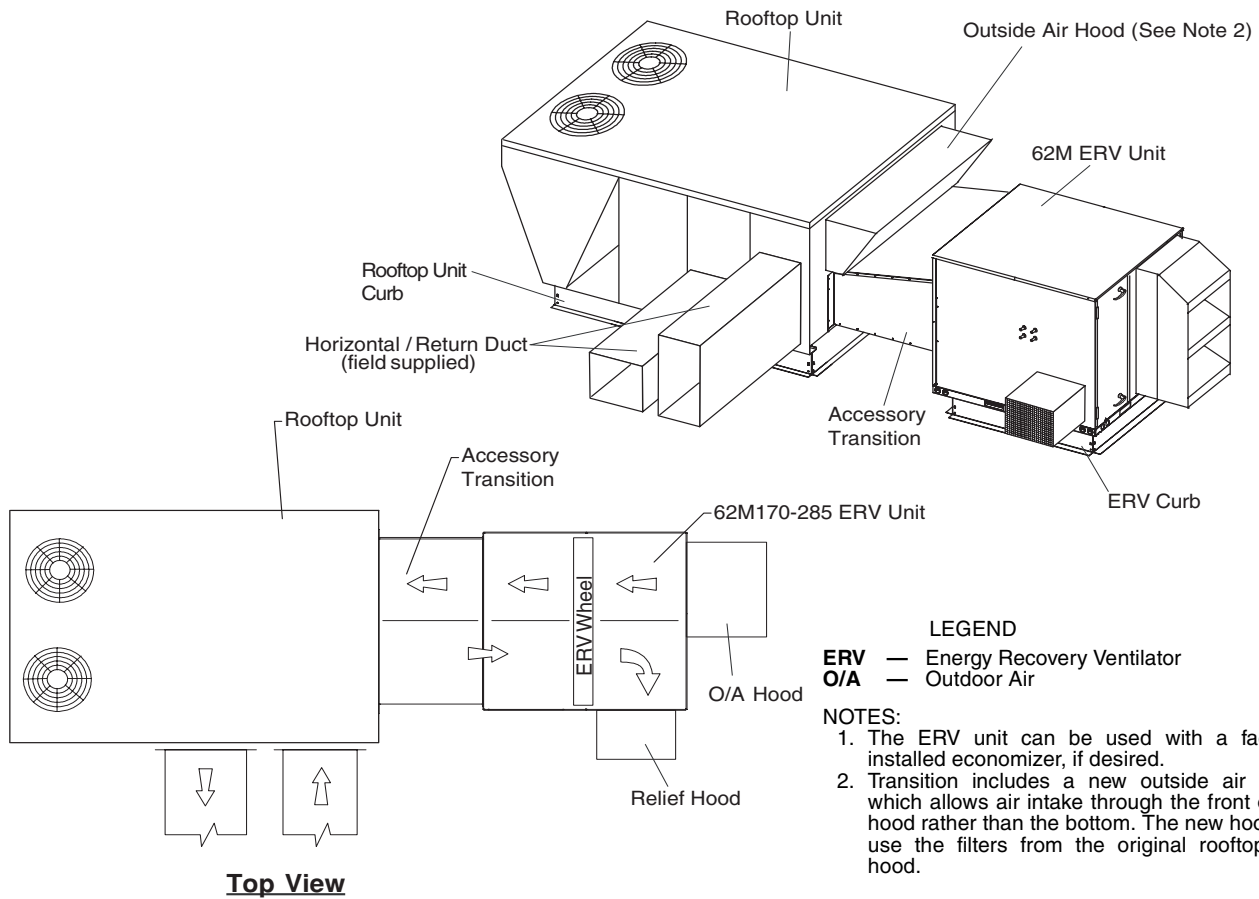
ROOFTOP MODEL	ROOFTOP SIZE	62M TRANSITION	ERV CURB	DIMENSIONS (in.)	
				A	B
48/50PG	03-07	62M-BTR-PG26-D	62M-A-CRB-14MC	80 <sup>5</sup> / <sub>16</sub>	44 <sup>11</sup> / <sub>16</sub>
	08-14	62M-BTR-PG712-D	62M-A-CRB-14MC	92 <sup>3</sup> / <sub>4</sub>	53 <sup>15</sup> / <sub>16</sub>

**Fig. 29 — 62MD,ME170-285 Coupled with Carrier 48/50PG03-14 Vertical Discharge Rooftop Unit**

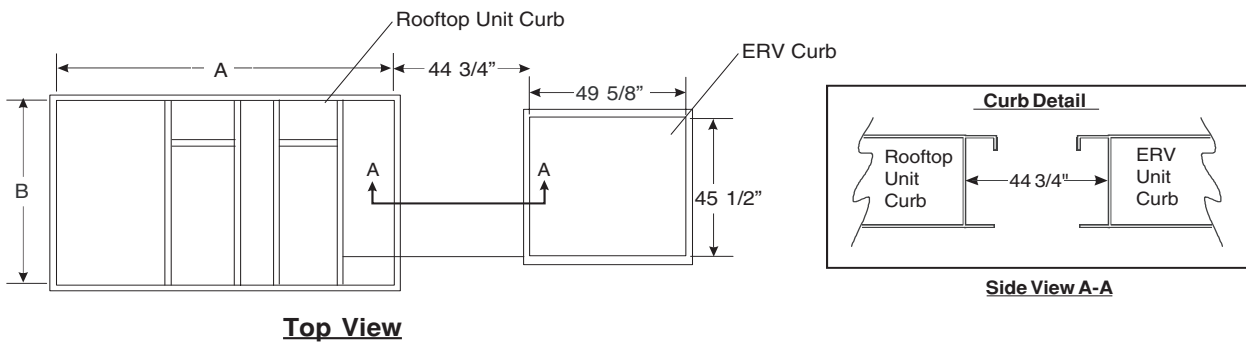


ROOFTOP MODEL	ROOFTOP SIZE	62M TRANSITION	ERV CURB	DIMENSIONS (in.)	
				A	B
48/50PG	03-07	62M-BTR-PG26-H	62M-B-CRB-14MC	80 <sup>5</sup> / <sub>16</sub>	44 <sup>11</sup> / <sub>16</sub>
	08-14	62M-BTR-PG712-H	62M-B-CRB-14MC	92 <sup>3</sup> / <sub>4</sub>	53 <sup>15</sup> / <sub>16</sub>

**Fig. 30 — 62MD,ME170-285 Coupled with Carrier 48/50PG03-14 Horizontal Discharge Rooftop Unit**

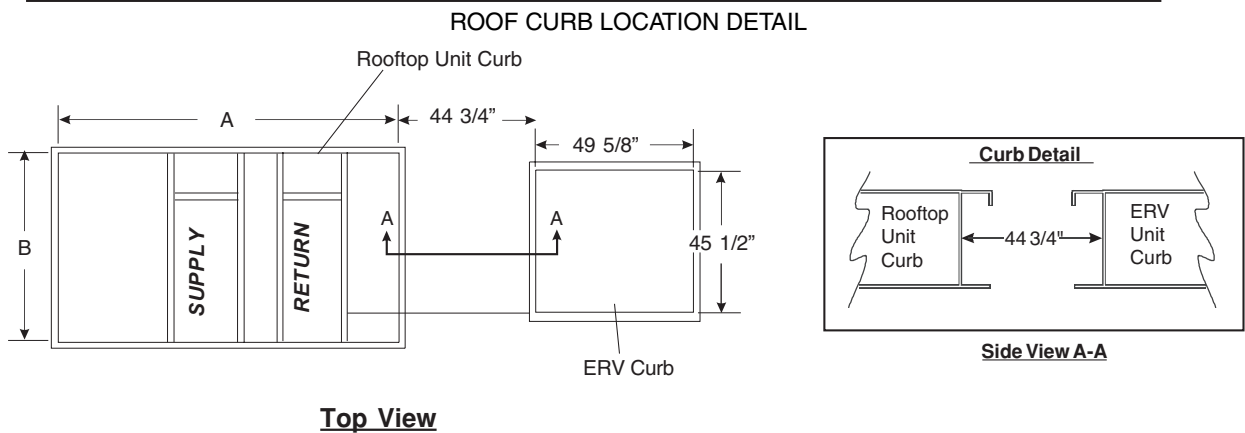
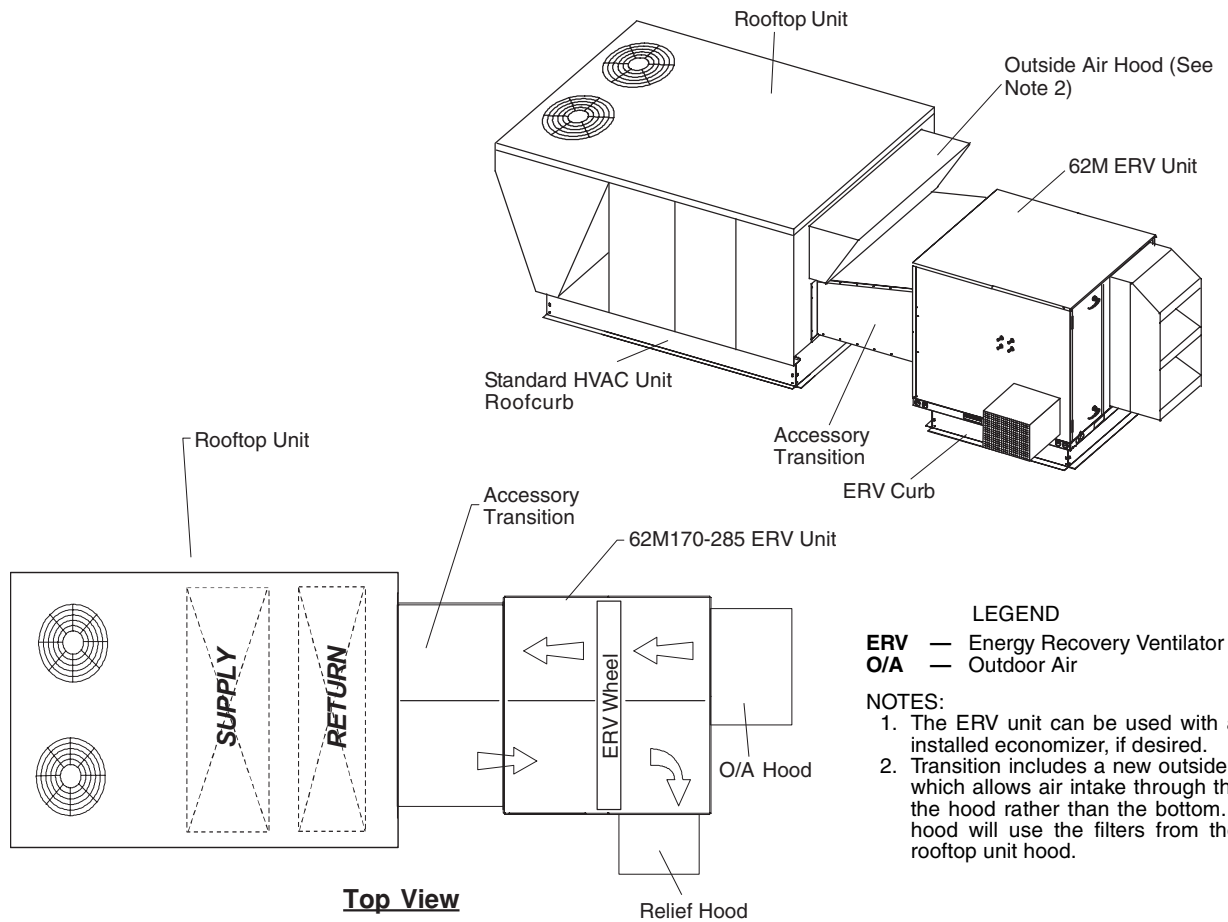


**ROOF CURB LOCATION DETAIL**



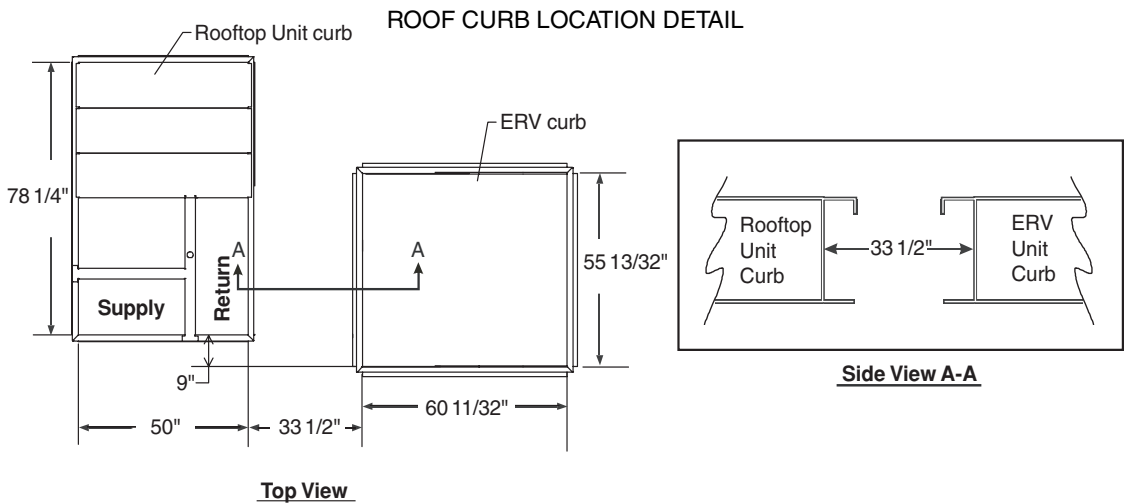
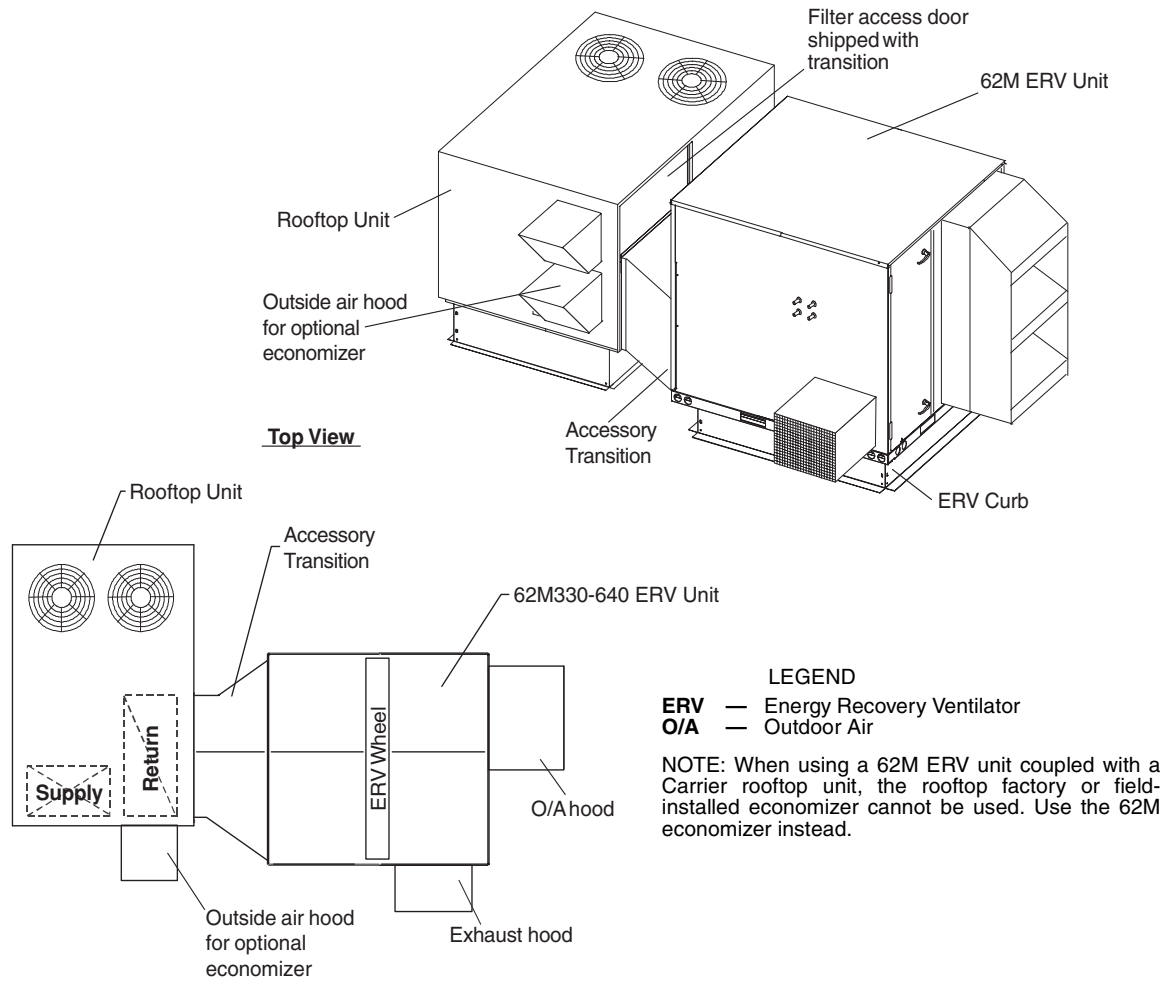
ROOFTOP MODEL	ROOFTOP SIZE	62M TRANSITION	ERV CURB	DIMENSIONS (in.)	
				A	B
48/50PG	20-28	62M-BTR-HG1525-H	62M-B-CRB-14MC	114.4	78.6
48/50HJ	020-028	62M-BTR-HG1525-H	62M-B-CRB-14MC	114.4	78.6

**Fig. 31 — 62MD,ME170-285 Coupled with Carrier 48/50PG20-28 and 48/50HJ020-028 Horizontal Discharge Rooftop Unit**



ROOFTOP MODEL	ROOFTOP SIZE	62M TRANSITION	ERV CURB	DIMENSIONS (in.)	
				A	B
48/50PG	20-28	62M-BTR-HG1525-D	62M-B-CRB-14MC	114.4	78.6
48/50HJ	020-028	62M-BTR-HG1525-D	62M-B-CRB-14MC	114.4	78.6

**Fig. 32 — 62MD,ME170-285 Coupled with Carrier 48/50PG20-28 and 48/50HJ020-028 Vertical Discharge Rooftop Unit**



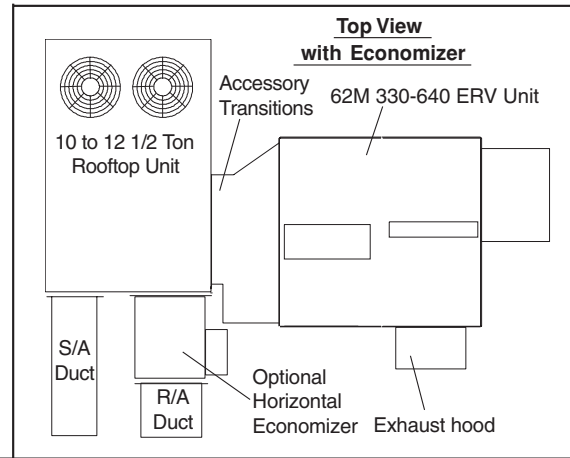
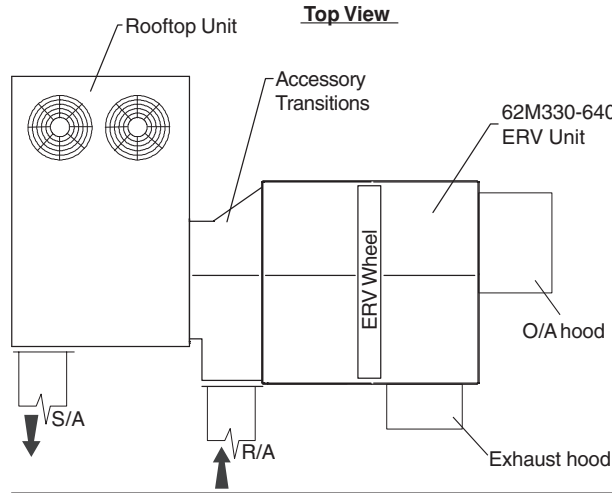
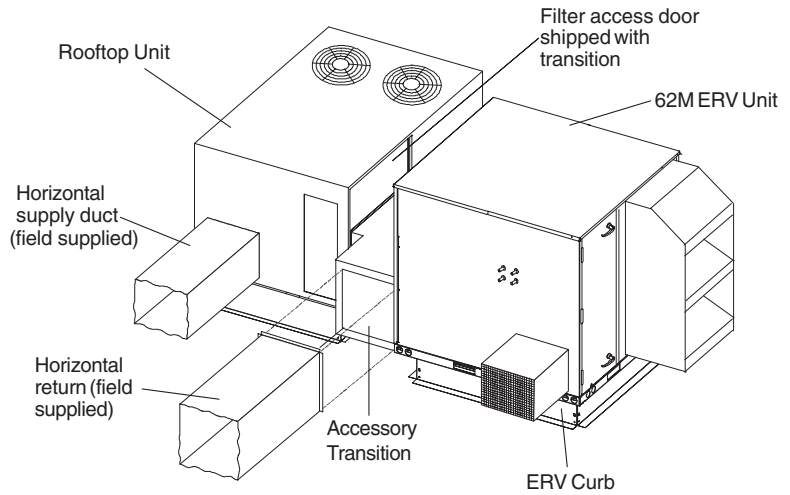
ROOFTOP UNIT MODEL	ROOFTOP SIZE	TRANSITION P/N	ERV CURB P/N	ROOFTOP ECONOMIZER
48/50HJ,TF,TJ,TM	012,014	62M-CTR-HJ1012-D	62M-C-CRB-14M	62MA-900---006

**Fig. 33 — 62MD,ME330-640 Coupled with Carrier 48/50HJ,TF,TJ,TM012,014 Vertical Discharge Rooftop Unit**

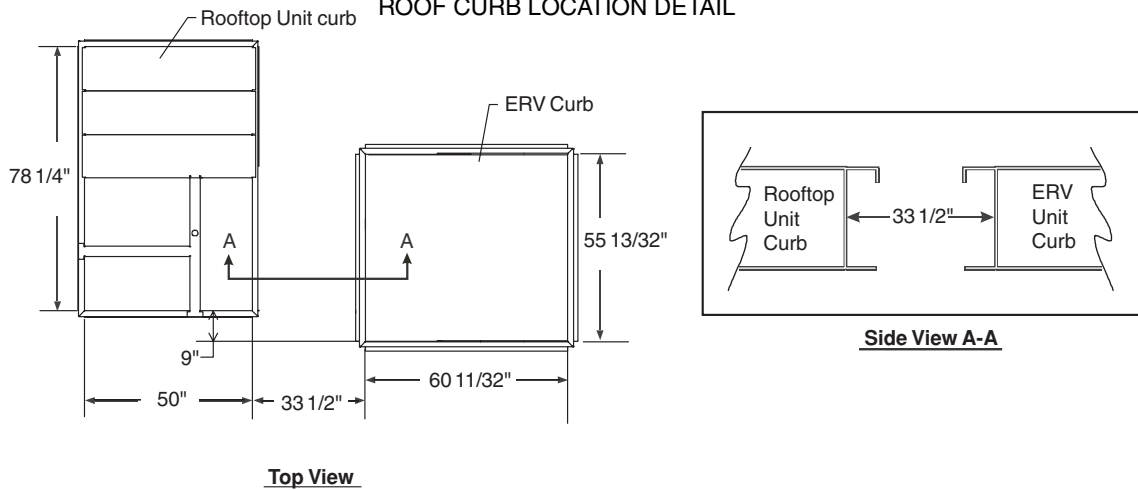


- LEGEND**  
**ERV** — Energy Recovery Ventilator  
**O/A** — Outdoor Air  
**R/A** — Return Air  
**S/A** — Supply Air

NOTE: When using a 62M ERV unit coupled with a Carrier rooftop unit, the rooftop factory or field-installed economizer cannot be used. Use the 62M economizer instead.



**ROOF CURB LOCATION DETAIL**



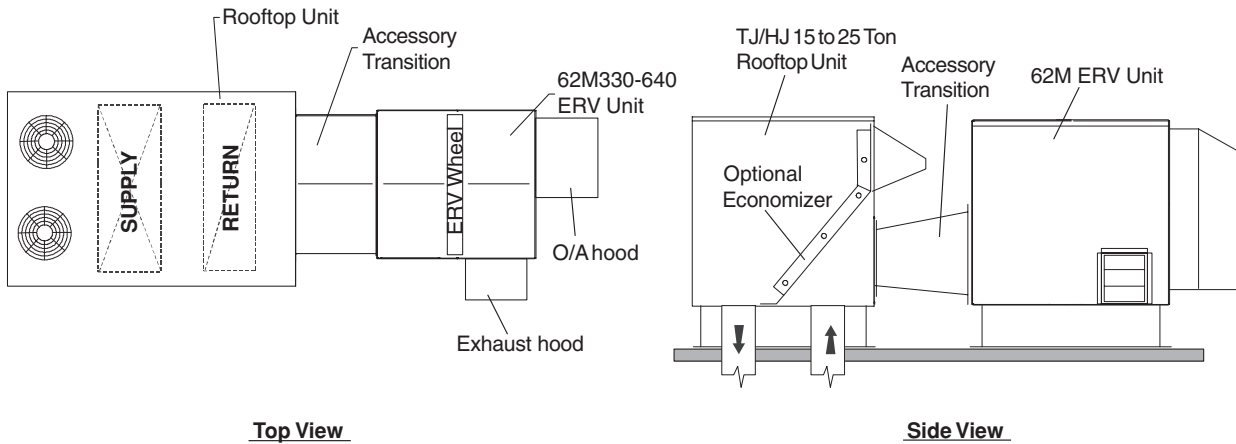
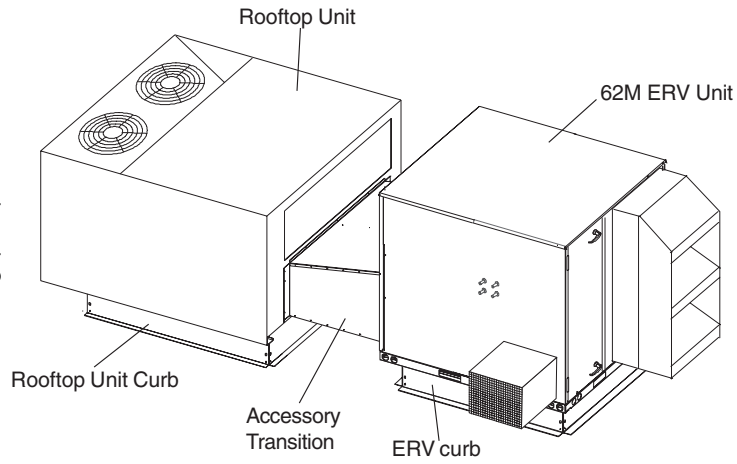
ROOFTOP UNIT MODEL	ROOFTOP SIZE	TRANSITION P/N	ERV CURB P/N	ROOFTOP ECONOMIZER
48/50HJ,TF,TJ,TM Without Economizer	012,014	62M-CTR-HJ1012-H	62M-C-CRB-14M	—
48/50HJ,TF,TJ,TM With Economizer	012,014	62M-CTR-HJ1012-HEC	62M-C-CRB-14M	62MA-900---010

Fig. 34 — 62MD,ME330-640 Coupled with Carrier 48/50HJ,TF,TJ,TM012,014 Horizontal Discharge Rooftop Unit

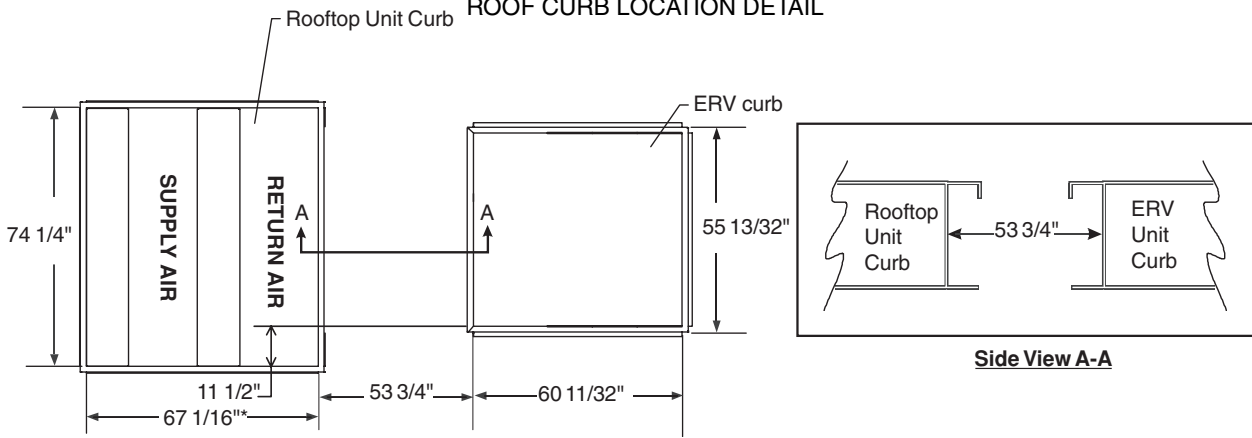
**LEGEND**  
**ERV** — Energy Recovery Ventilator  
**O/A** — Outdoor Air

**NOTES:**

1. The ERV unit can be used with a factory-installed economizer, if desired.
2. The ERV cannot be coupled with a horizontal return 48/50TJ, TM or HJ 15 to 25 ton rooftop unit.



**ROOF CURB LOCATION DETAIL**

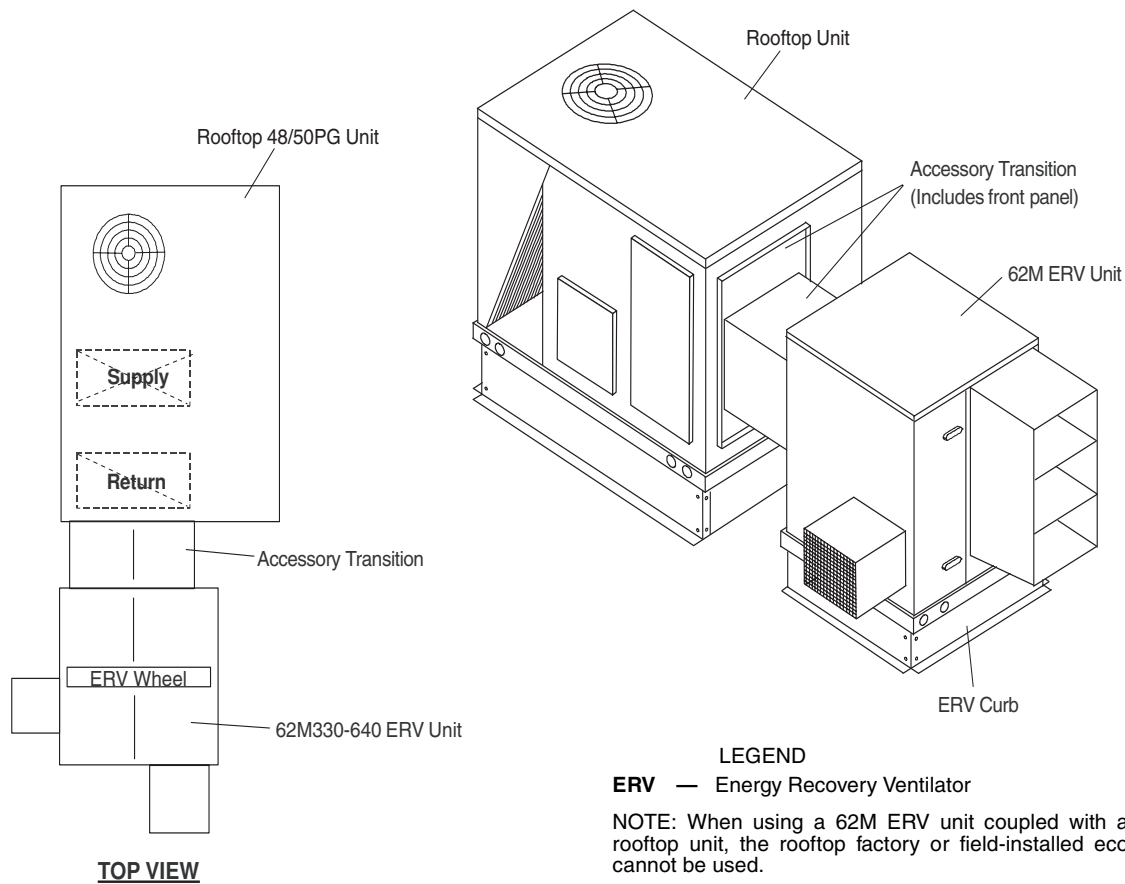


**Top View**

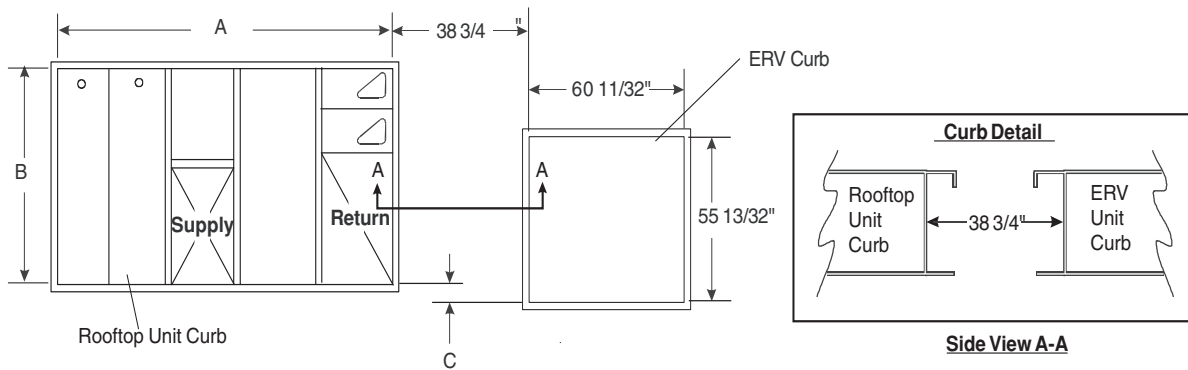
\*Length is 89<sup>1</sup>/<sub>16</sub>” for 48/50TM028 units.

ROOFTOP UNIT MODEL	ROOFTOP SIZE	TRANSITION P/N	ERV CURB P/N
48/50TJ, TM	016-028	62M-BTR-HJ1525-D	62M-B-CRB-14S
48/50HJ	015,017	62M-BTR-HJ1525-D	62M-B-CRB-14S

**Fig. 35 — 62MD,ME330-640 Coupled with Carrier 48/50TJ, TM016-028 and 48/50HJ015,017 Vertical Discharge Rooftop Unit**

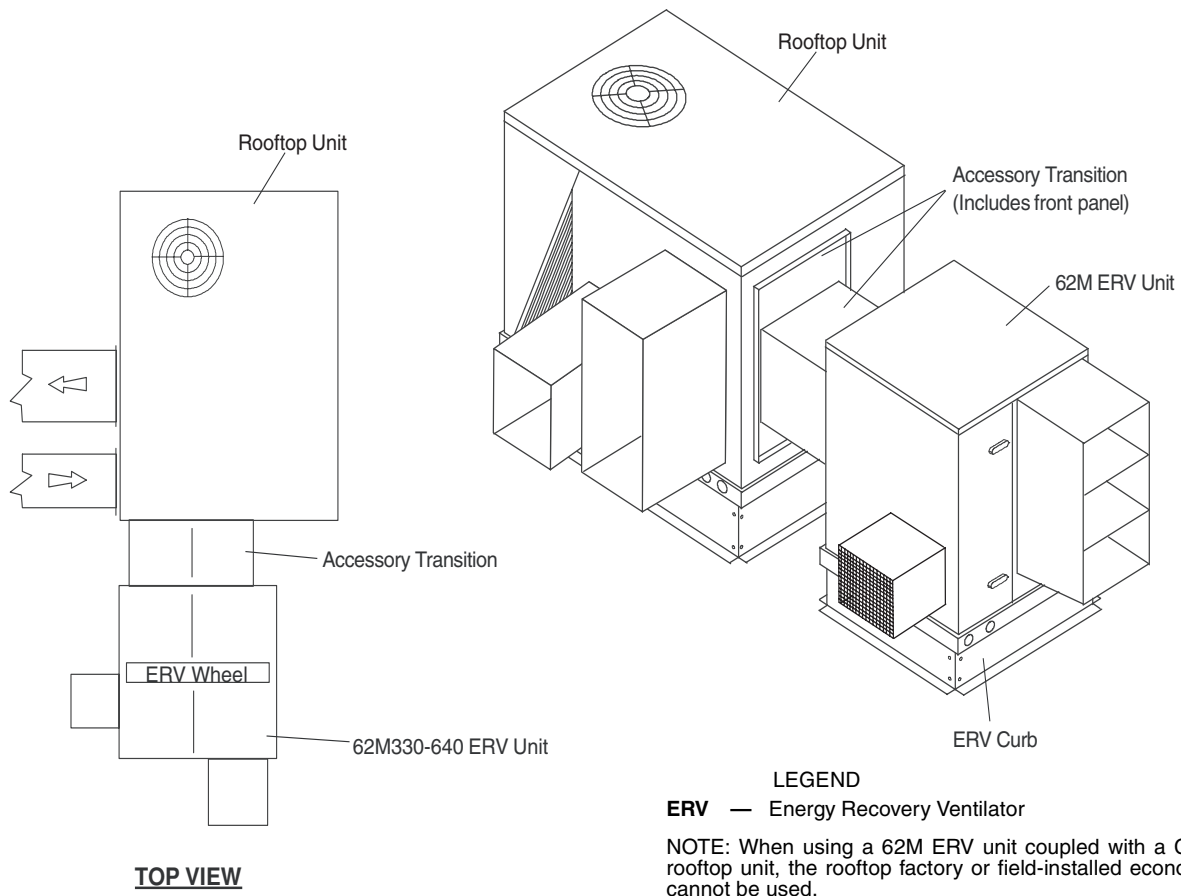


**ROOF CURB LOCATION DETAIL**



ROOFTOP UNIT MODEL	ROOFTOP SIZE	62M TRANSITION	ERV CURB	DIMENSIONS (in.)		
				A	B	C
48/50PG	08-14	62M-CTR-PG712-D	62M-C-CRB-14M	92 <sup>3</sup> / <sub>4</sub>	53 <sup>15</sup> / <sub>16</sub>	10

**Fig. 36 — 62MD,ME330-640 Coupled with Carrier 48/50PG08-14 Vertical Discharge Rooftop Unit**

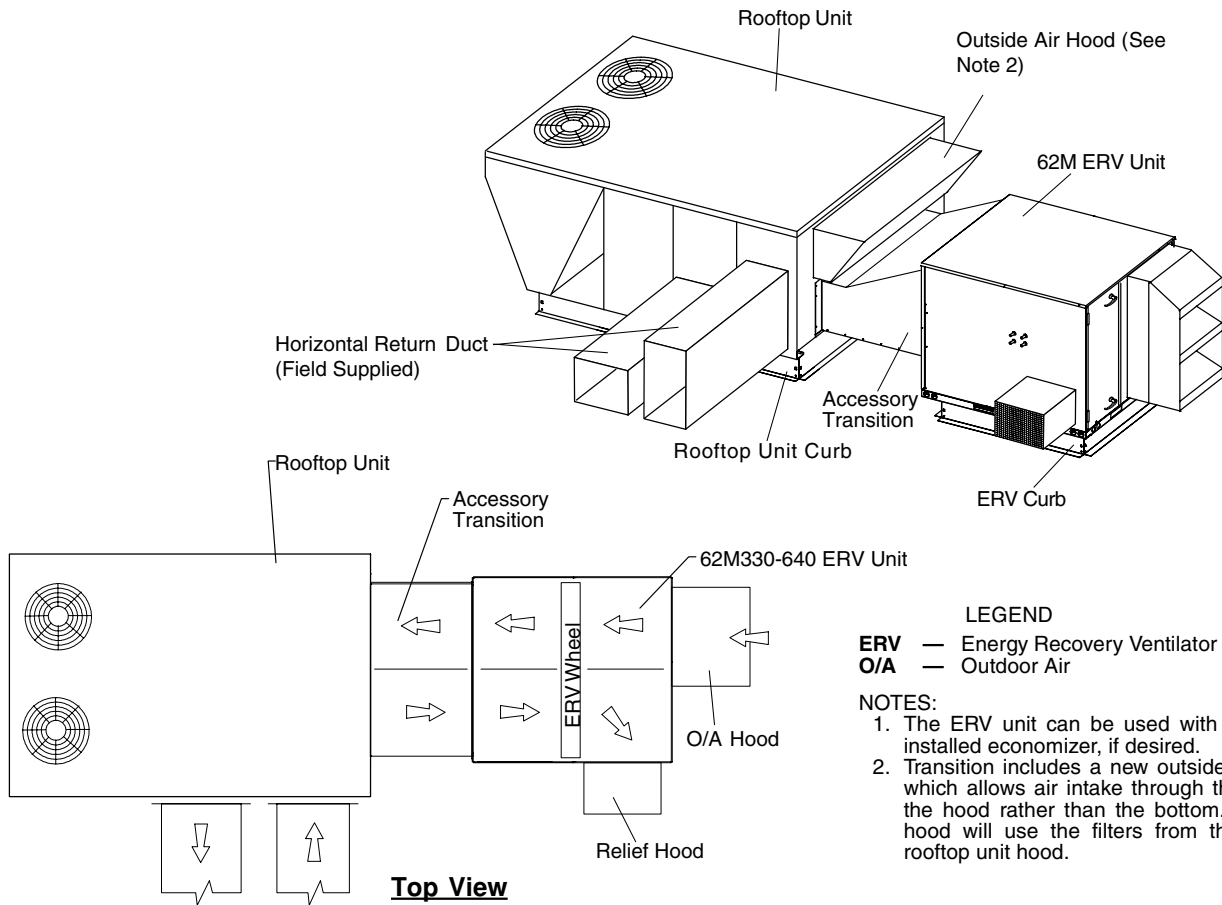


**ROOF CURB LOCATION DETAIL**

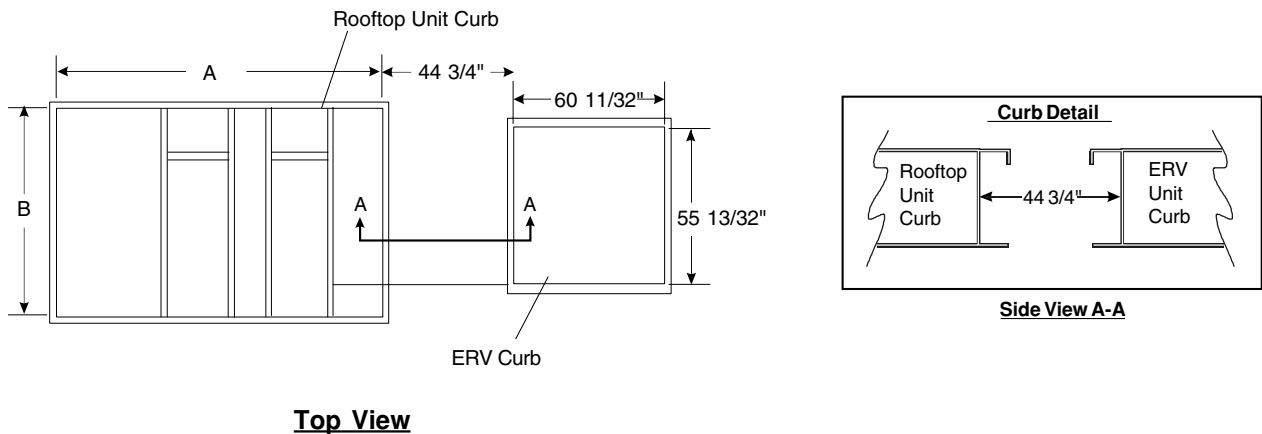


ROOFTOP UNIT MODEL	ROOFTOP SIZE	62M TRANSITION	ERV CURB	DIMENSIONS (in.)		
				A	B	C
48/50PG	08-14	62M-CTR-PG712-H	62M-C-CRB-14M	92 <sup>3</sup> / <sub>4</sub>	53 <sup>15</sup> / <sub>16</sub>	10

**Fig. 37 — 62MD,ME330-640 Coupled with Carrier 48/50PG08-14 Horizontal Discharge Rooftop Unit**

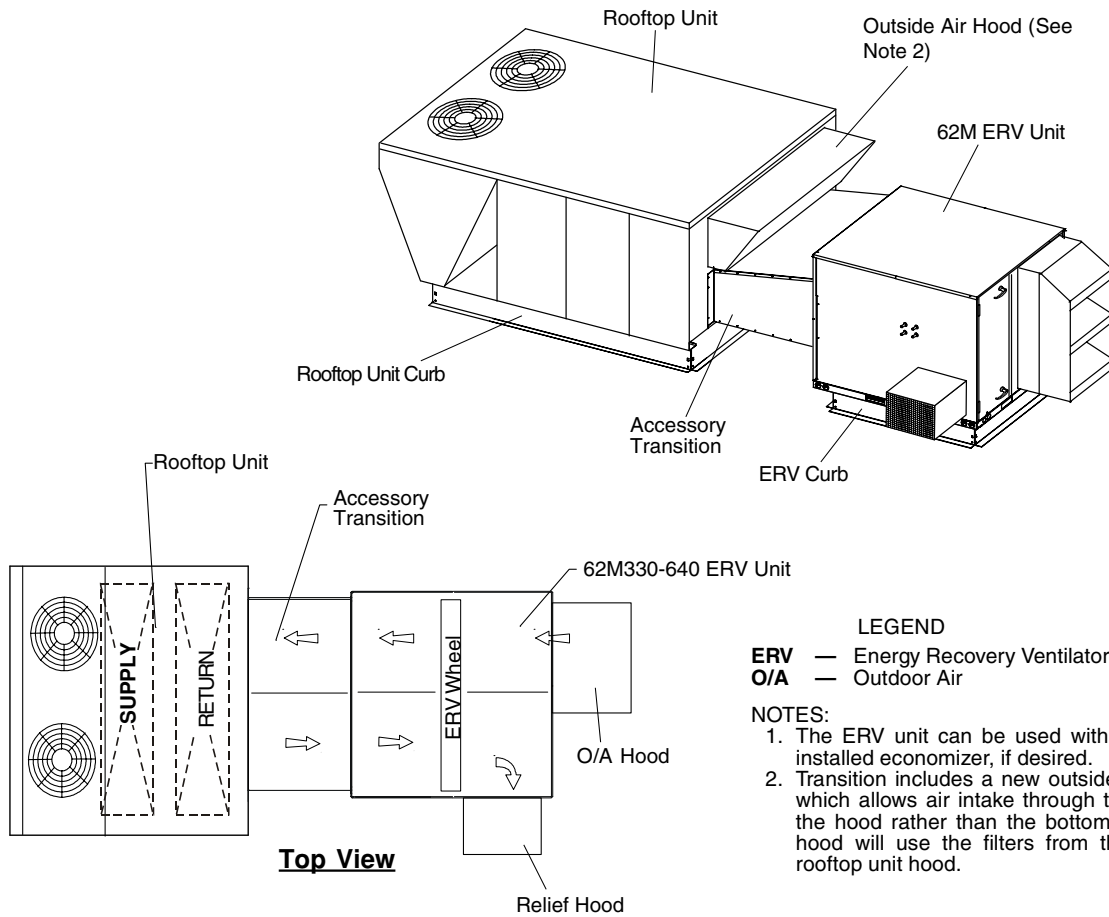


**ROOF CURB LOCATION DETAIL**

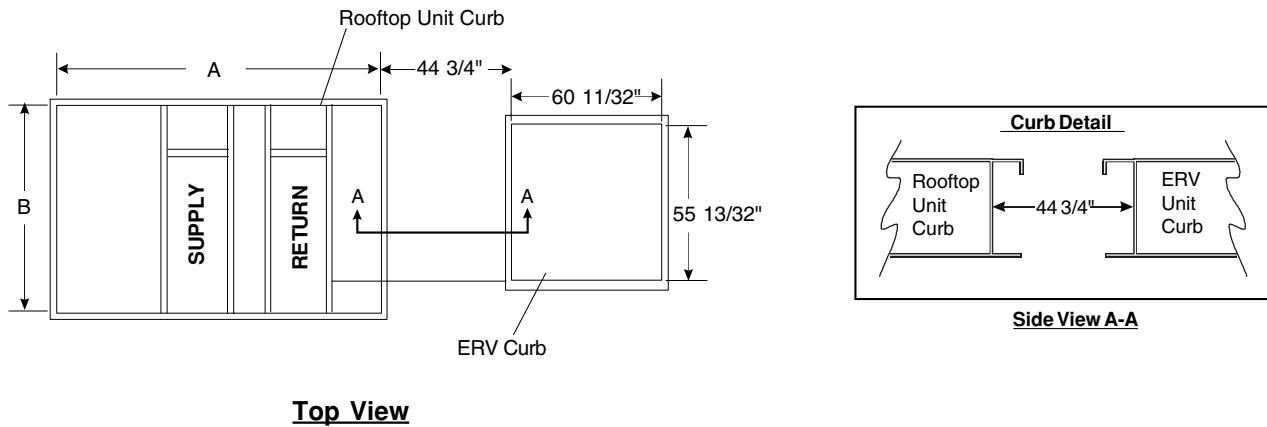


ROOFTOP MODEL	ROOFTOP SIZE	62M TRANSITION	ERV CURB	DIMENSIONS (in.)	
				A	B
48/50PG	20-28	62M-CTR-HG1525-H	62M-C-CRB-14M	114.4	78.6
48/50HJ	020-028	62M-CTR-HG1525-H	62M-B-CRB-14M	114.4	78.6

**Fig. 38 — 62MD,ME330-640 Coupled with Carrier 48/50PG20-28 and 48/50HJ020-028 Horizontal Discharge Rooftop Unit**

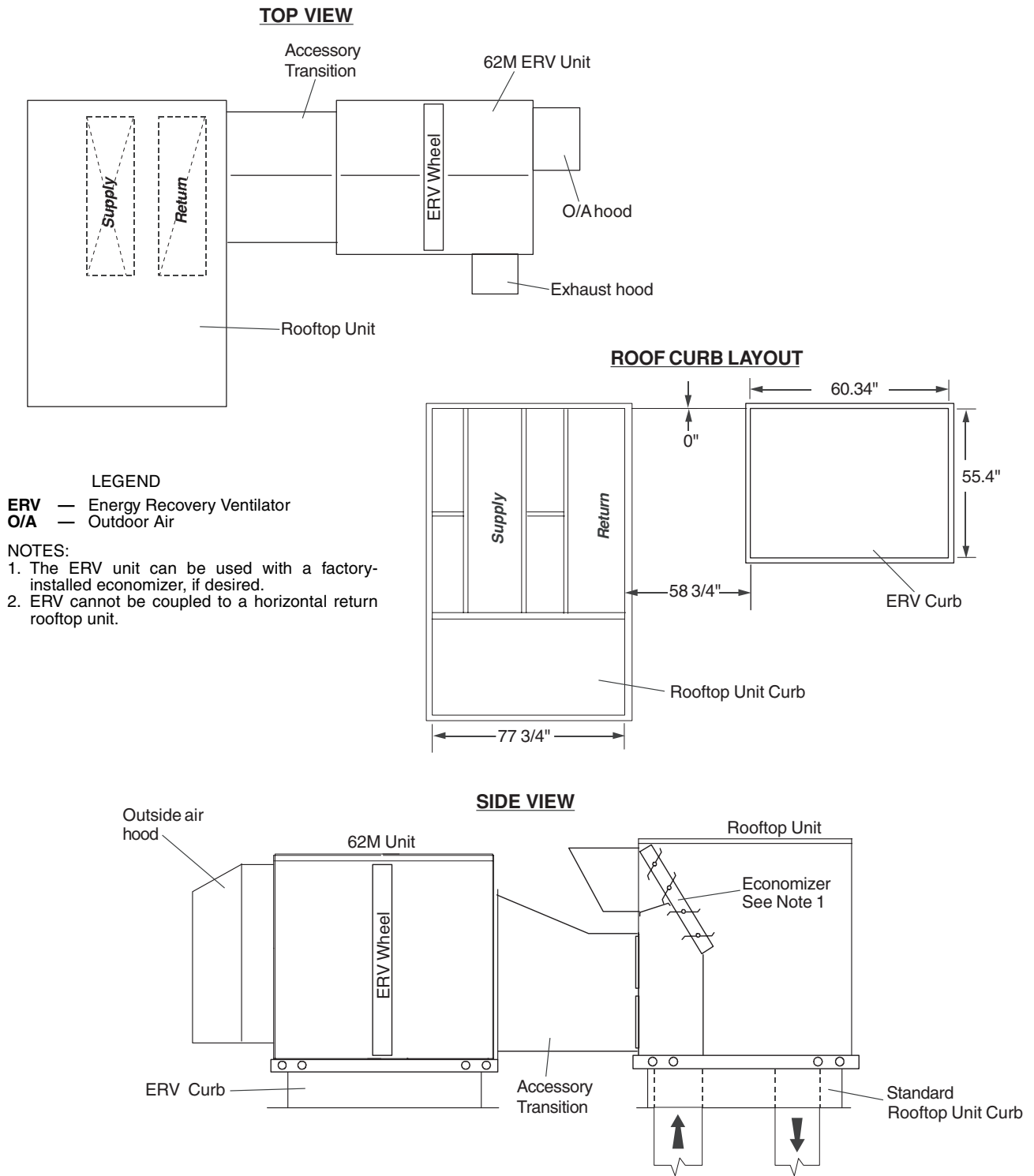


**ROOF CURB LOCATION DETAIL**



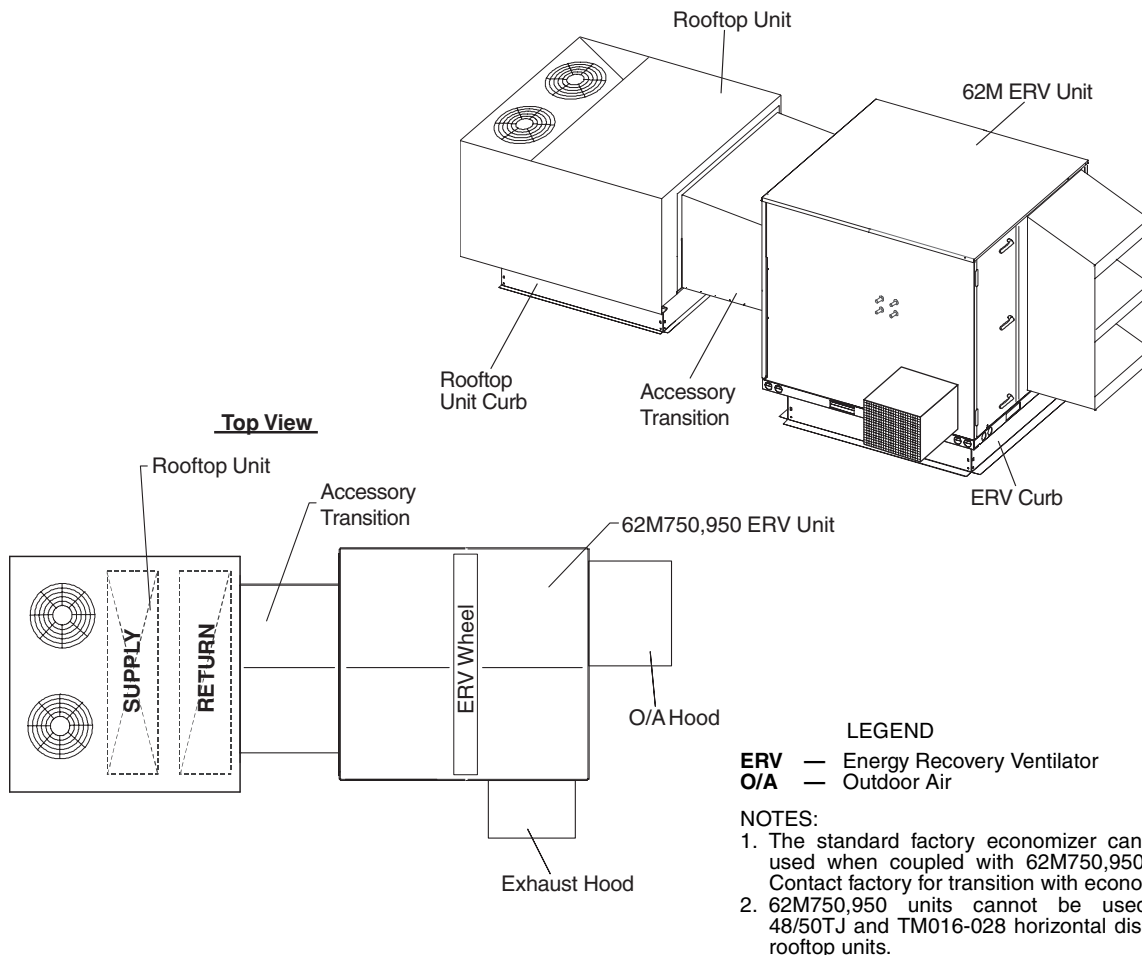
ROOFTOP MODEL	ROOFTOP SIZE	62M TRANSITION	ERV CURB	DIMENSIONS (in.)	
				A	B
48/50PG	20-28	62M-CTR-HG1525-D	62M-C-CRB-14M	114.4	78.6
48/50HJ	020-028	62M-CTR-HG1525-D	62M-B-CRB-14M	114.4	78.6

**Fig. 39 — 62MD,ME330-640 Coupled with Carrier 48/50PG20-28 and 48/50HJ020-028 Vertical Discharge Rooftop Unit**

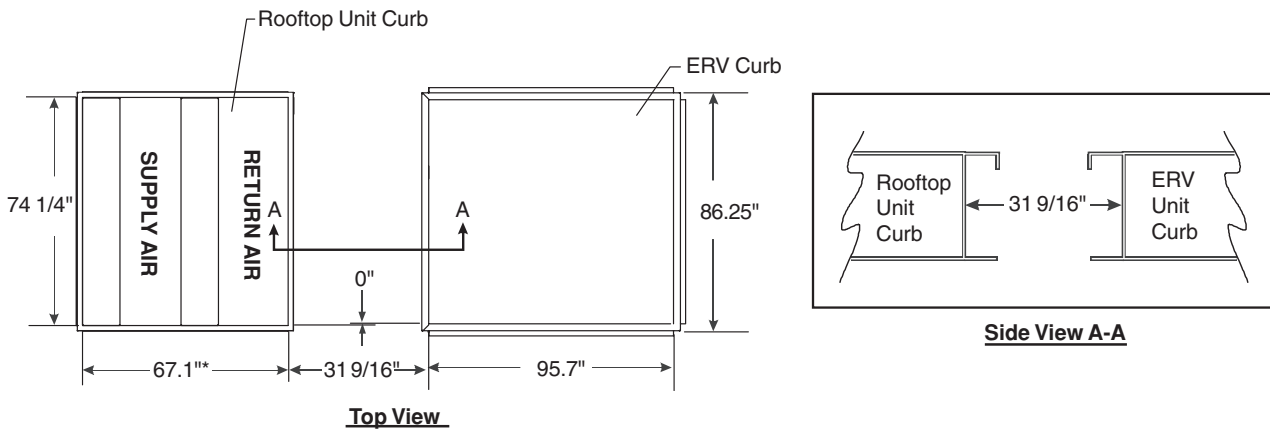


ROOFTOP UNIT MODEL	ROOFTOP SIZE	TRANSITION P/N	ERV CURB P/N
48/50A	020-060	62M-CTR-AJ2060-D	62M-C-CRB-14M

**Fig. 40 — 62MD,ME330-640 Coupled with Carrier 48/50A020-060 Vertical Discharge Rooftop Unit**



**ROOF CURB LOCATION DETAIL**

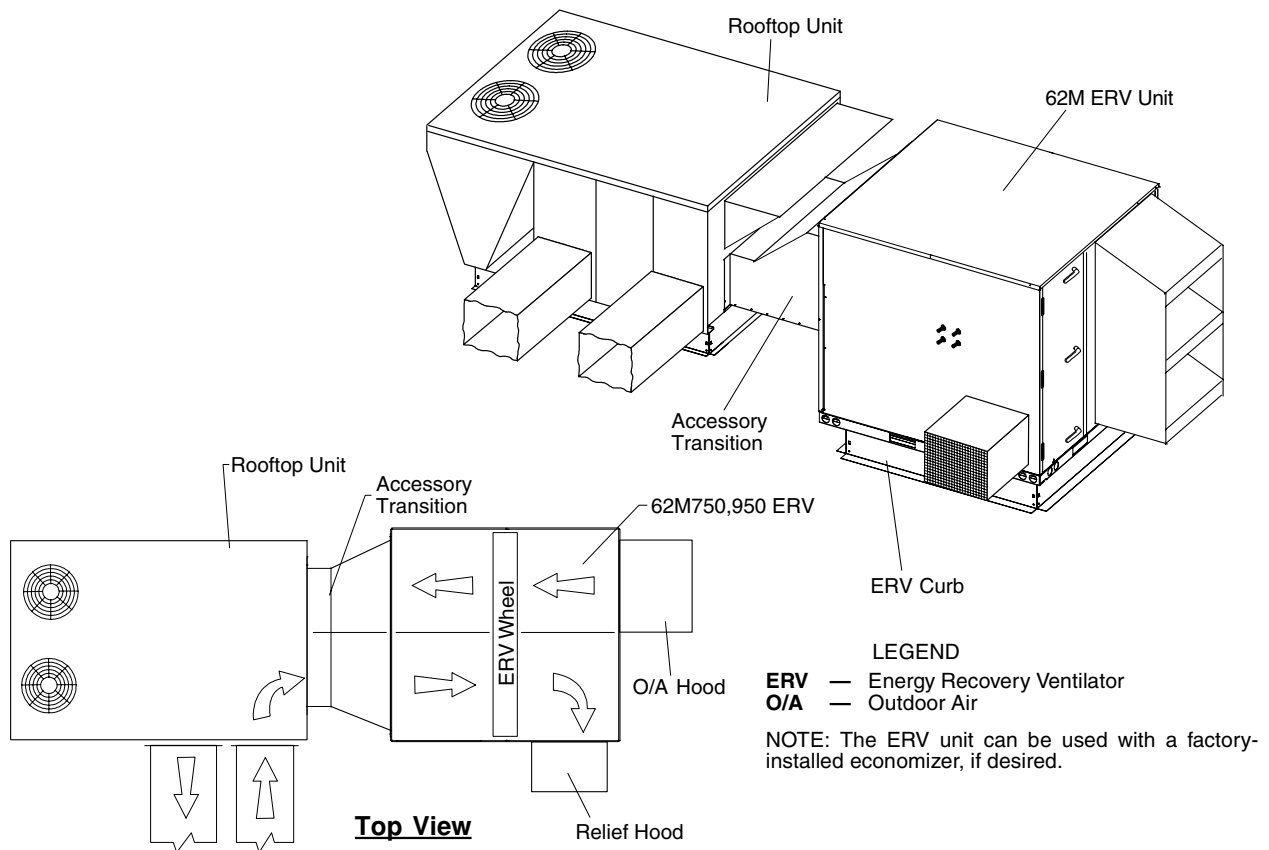


\*Length is 89<sup>1</sup>/<sub>16</sub>" for 48/50TM028 units.

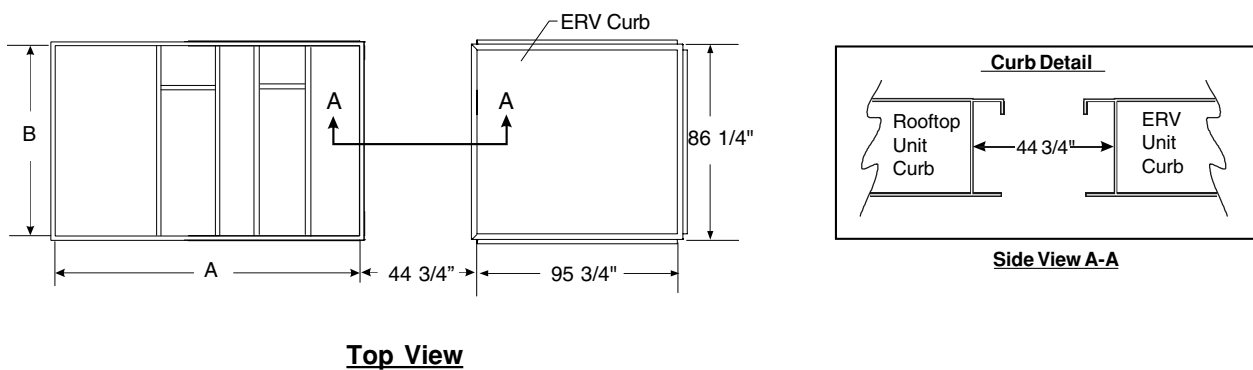
ROOFTOP UNIT MODEL	ROOFTOP SIZE	TRANSITION P/N	ERV CURB P/N	ROOFTOP ECONOMIZER
48/50TJ, TM	016-028	62M-DTR-HJ1525-D	62M-D-CRB-14M	62MA-900---007
48/50HJ	015,017	62M-DTR-HJ1525-D	62M-D-CRB-14M	62MA-900---007

**Fig. 41 — 62MD,ME750,950 Coupled with Carrier 48/50TJ, TM016-028 and 48/50HJ015,017 Vertical Discharge Rooftop Unit**



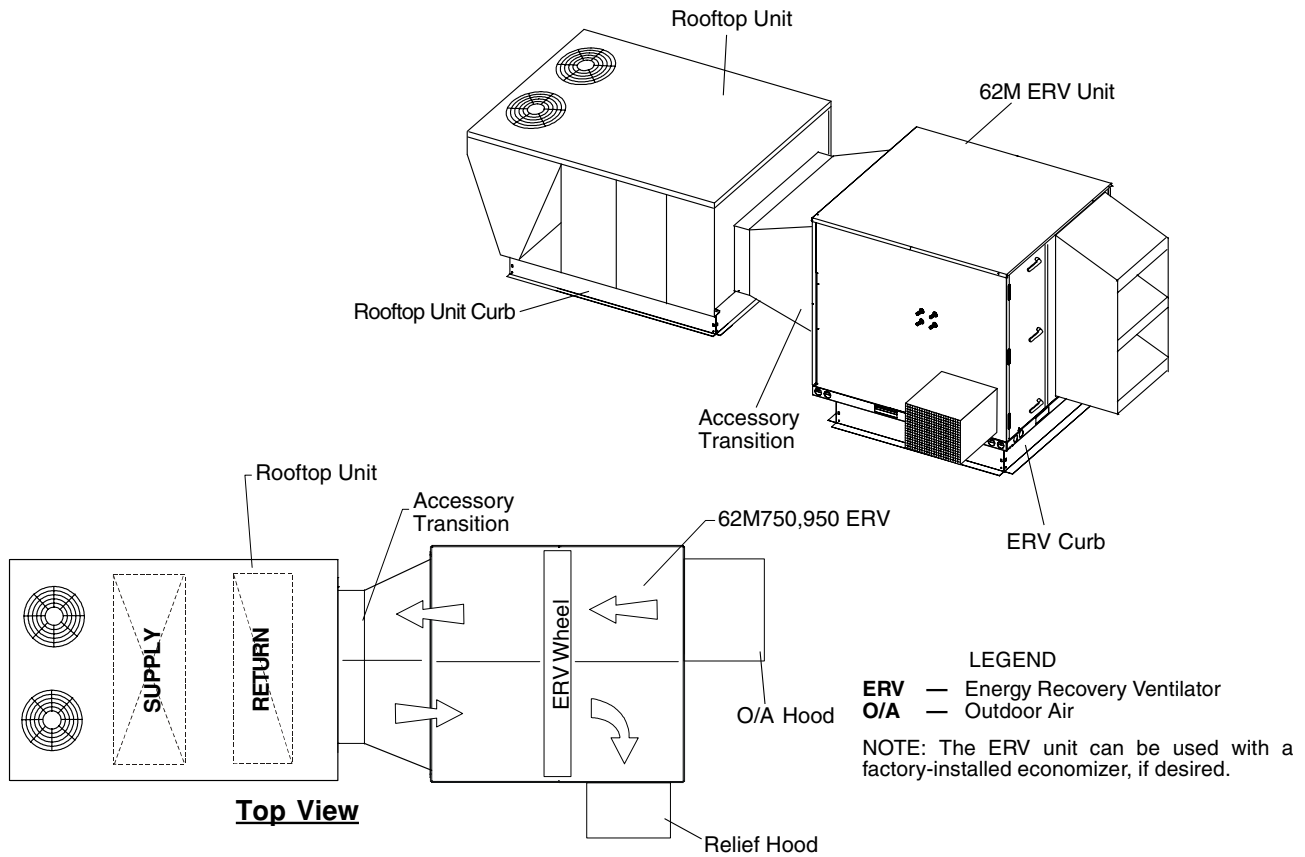


**ROOF CURB LOCATION DETAIL**

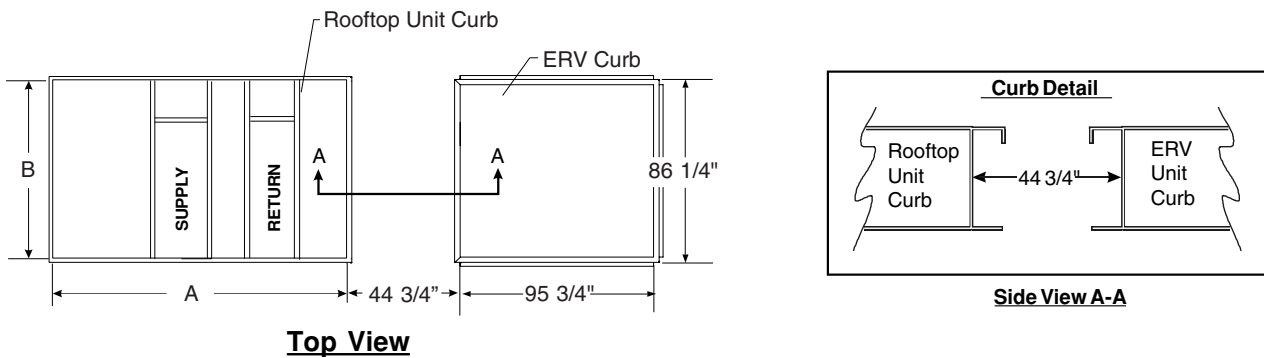


ROOFTOP MODEL	ROOFTOP SIZE	62M TRANSITION	ERV CURB	DIMENSIONS (in.)	
				A	B
48/50PG	20-28	62M-DTR-HG1525-H	62M-D-CRB-14M	114.4	78.6
48/50HJ	020-028	62M-DTR-HG1525-H	62M-D-CRB-14M	114.4	78.6

**Fig. 42 — 62MD,ME750,950 Coupled with Carrier 48/50PG20-28 and 48/50HJ020-028 Vertical Discharge Rooftop Unit**

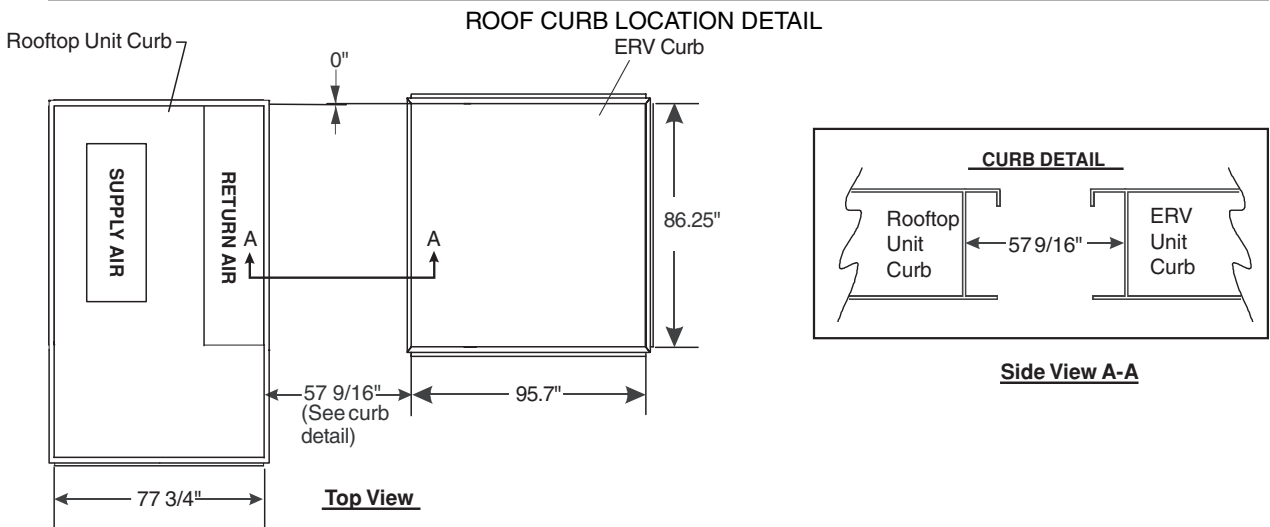
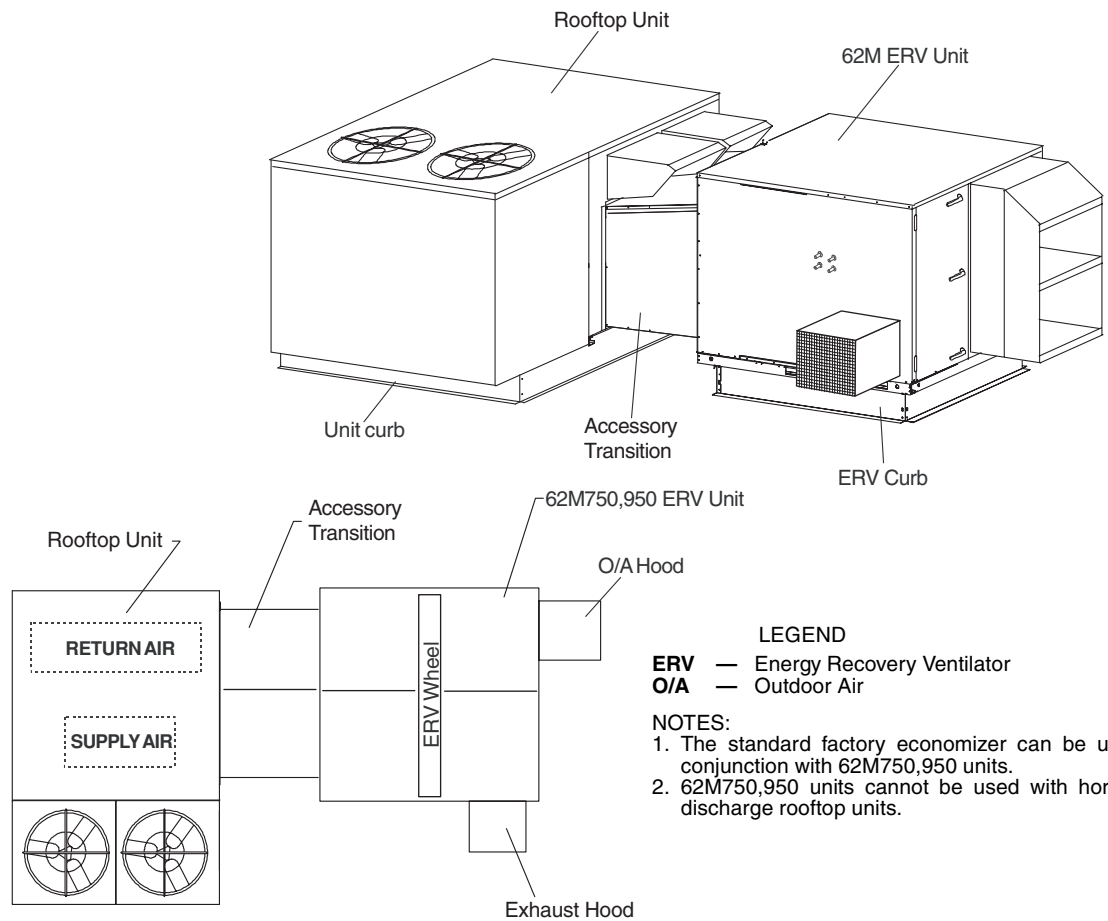


**ROOF CURB LOCATION DETAIL**



ROOFTOP MODEL	ROOFTOP SIZE	62M TRANSITION	ERV CURB	DIMENSIONS (in.)	
				A	B
48/50PG	20-28	62M-DTR-HG1525-D	62M-D-CRB-14M	114.4	78.6
48/50HJ	020-028	62M-DTR-HG1525-D	62M-D-CRB-14M	114.4	78.6

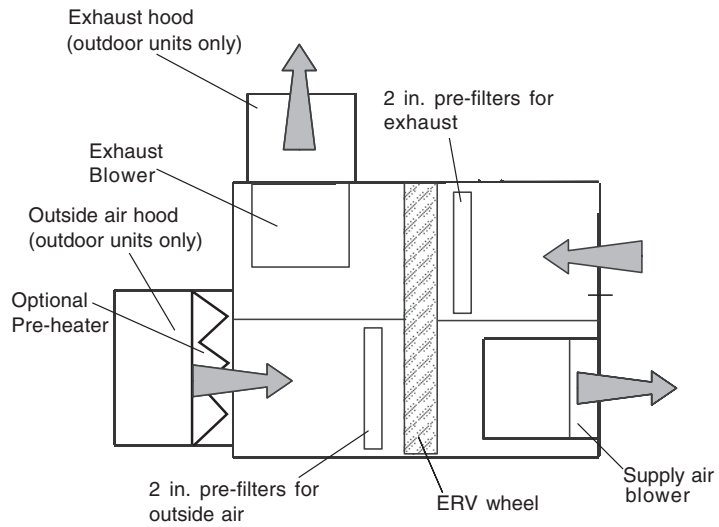
**Fig. 43 — 62MD,ME750,950 Coupled with Carrier 48/50PG20-28 and 48/50HJ020-028 Vertical Discharge Rooftop Unit**



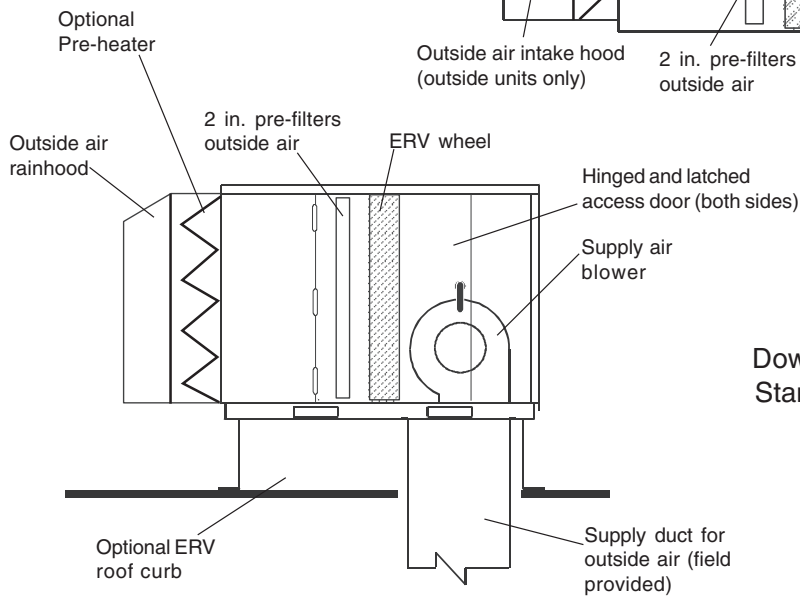
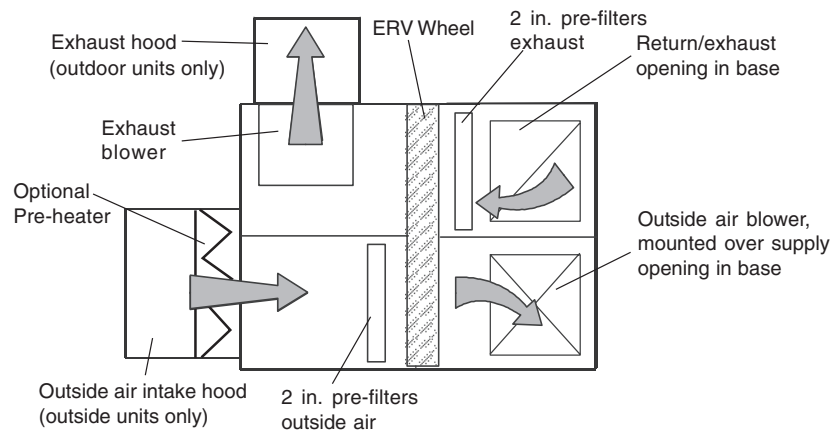
ROOFTOP UNIT MODEL	ROOFTOP SIZE	TRANSITION P/N	ERV CURB P/N
48/50A	020-060	62M-DTR-AJ2060-D	62M-D-CRB-14M

**Fig. 44 — 62MD,ME750,950 Coupled with Carrier 48/50A020-060 Rooftop Unit**

**Top View**  
Horizontal Discharge -  
Stand-Alone Unit



**Top View**  
Down Discharge -  
Stand-Alone Unit



**Side View**  
Down Discharge -  
Stand-Alone Unit

**Fig. 45 — 62M Airflow in Stand-Alone Applications**

**Step 3 — Rigging and Handling** — To transfer the unit from the shipping platform to the storage or installation site, refer to the rigging label on the unit and these instructions.

**⚠ CAUTION**

All panels must be in place when rigging. Unit is not designed for handling by fork truck. Damage to unit may result.

Refer to Table 1 for ERV unit weights. Check lifting devices for capacity constraints.

Hook rigging shackles through the holes or lifting eyes in the ERV unit.

NOTE: Some 62M units have lifting eyes, some 62M units have holes in the ERV base rail. See Fig. 46.

Connect lifting straps and spreader bars. See Fig. 46. Spreader bars must be positioned to prevent cables from rubbing against the ERV unit.

Carefully lift the ERV unit and set on ERV roof curb. Do not drop the ERV unit onto the roof curb, as damage may occur. Avoid twisting or uneven lifting of the unit. Never lift the unit by the hoods or any means other than the provided lifting holes or eyes.

**MOUNTING THE ERV UNIT INDOORS** — The ERV unit can be mounted indoors. Follow all local and other applicable building codes.

**⚠ CAUTION**

All panels must be secured in place prior to lifting the ERV unit in to place. Follow all local and other applicable codes when lifting, locating and mounting the ERV unit. Damage to unit may result.

**Locate the ERV Unit** — Prior to locating the indoor ERV unit consider the intake and exhaust duct accessibility to outside walls or roof vents. When locating the ERV unit consider required service clearances.

See Table 1 for unit weights to determine if building structure reinforcements are required.

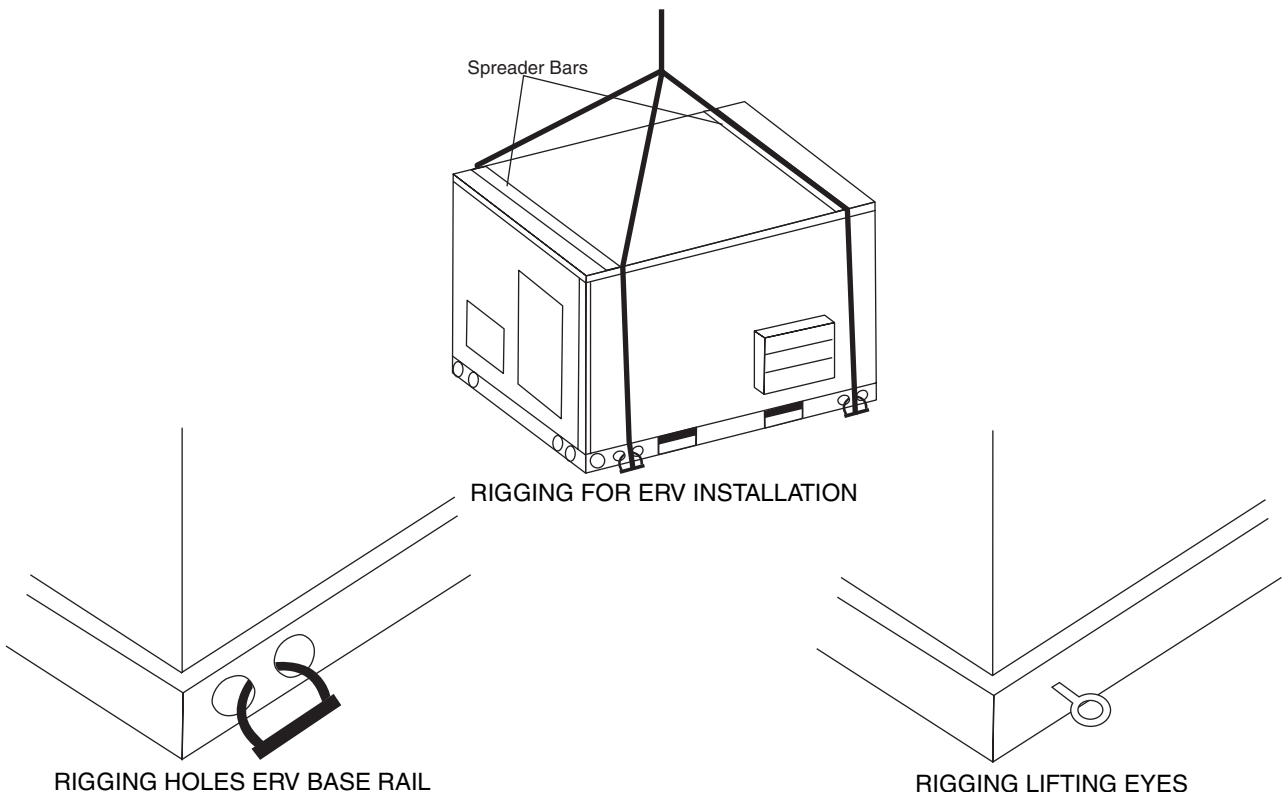
**Determine a Method for Mounting** — The method for mounting and securing the ERV unit to the building structure must be field designed and installed. Mounting methods will vary depending upon specific jobsite conditions.

NOTE: Hardware and pieces to secure ERV unit to the building structure must not interfere with the service clearances or duct requirements for the unit.

**Lift the ERV Unit in Place** — Secure the ERV unit to the building structure following all applicable local building codes.

**⚠ CAUTION**

Do not use the ERV duct system to support the ERV unit in any way. Follow all local and applicable building codes and manufacture and install the ductwork to the ERV unit per the duct opening connections. Equipment damage or personal injury may result.



**Fig. 46 — Rigging Details**

**Table 1 — Physical Data**

UNIT 62M	040	075	120	170	225	285
<b>NOMINAL CAPACITY (cfm)</b>	400	750	1200	1700	2250	2850
<b>CAPACITY RANGE (cfm)</b>	100-550	500-1000	1000-1400	1400-2000	2000-2500	2500-3200
<b>MAXIMUM SHIPPING WEIGHT (lb)</b>						
Single-Wall Models	255	440	462	850	900	1000
Double-Wall Models	367	635	657	1135	1185	1285
<b>MAXIMUM OPERATING WEIGHT (lb)</b>						
Single-Wall Models	235	400	422	790	840	940
Double-Wall Models	347	595	617	1075	1125	1225
<b>62MB,MC INDOOR UNIT DIMENSIONS (in.)</b>						
Length*	29.75	43.25	43.25	62.63	62.63	62.63
Width	29.88	39.13	39.13	58.38	58.38	58.38
Height	29.75	37.88	37.88	48.88	48.88	48.88
<b>62MD,ME OUTDOOR UNIT DIMENSIONS (in.)†</b>						
Length*	48.43	60.75	60.75	87.13	87.13	87.13
Width	31.24	50.13	55.13	69.38	69.38	69.38
Height	29.72	37.88	37.88	48.88	48.88	48.88
<b>ROTARY ENERGY EXCHANGER</b>	Enthalpy Lightweight Polymer with Silica Gel Desiccant Coating					
Type						
Size (Diam. x Depth) (in.)	22.5 x 2	29.0 x 2	29.0 x 3	40.0 x 1.5	40.0 x 1.5	40.0 x 3
Nominal Drive Motor Hp	N/A	N/A	N/A	1/6	1/6	1/6
<b>SUPPLY/EXHAUST AIR FAN</b>	2...Forward Curved Centrifugal Adjustable Belt Drive Neoprene Pads					
Qty...Type	Direct					
Drive Type						
Fan Isolation						
Wheel Dimensions (Diam. x Width)	5.5 x 5.5	9 x 7	9 x 7	12 x 12	12 x 12	12 x 12
Nominal Motor Hp	1/4	1/2	1	1	2	2
<b>FILTERS (optional)</b>	2-in. Pleated — 30% Efficiency					
Type						
Exhaust Air...Qty...Size (L x W x D) (in.)	1....12 x 20 x 2	1....18 x 25 x 2	1....18 x 25 x 2	2....20 x 25 x 2	2....20 x 25 x 2	2....20 x 25 x 2
Outside Air...Qty...Size (L x W x D) (in.)	1....12 x 20 x 2	1....18 x 25 x 2	1....18 x 25 x 2	2....20 x 25 x 2	2....20 x 25 x 2	2....20 x 25 x 2

UNIT 62M	330	430	550	640	750	950
<b>NOMINAL CAPACITY (cfm)</b>	3300	4300	5500	6400	7500	9500
<b>CAPACITY RANGE (cfm)</b>	3000-3600	3600-5000	5000-6000	6000-6800	6500-8500	8500-10,500
<b>MAXIMUM SHIPPING WEIGHT (lb)</b>						
Single-Wall Models	1300	1350	1440	1590	2650	2750
Double-Wall Models	1710	1760	1850	2000	3270	3370
<b>MAXIMUM OPERATING WEIGHT (lb)</b>						
Single-Wall Models	1220	1270	1360	1510	2550	2650
Double-Wall Models	1630	1680	1770	1920	3170	3270
<b>62MB,MC INDOOR UNIT DIMENSIONS (in.)</b>						
Length	73.13	73.13	73.13	73.13	108.3	108.3
Width	67.89	67.89	67.89	67.89	97.87	97.87
Height	65.21	65.21	65.21	65.21	77.4	77.4
<b>62MD,ME OUTDOOR UNIT DIMENSIONS (in.)†</b>						
Length	100.88	100.88	100.88	100.88	143.45	143.45
Width	87.89	87.89	87.89	87.89	121.87	121.87
Height	65.21	65.21	65.21	65.21	77.4	77.4
<b>ROTARY ENERGY EXCHANGER</b>	Enthalpy Lightweight Polymer with Silica Gel Desiccant Coating					
Type						
Size (Diam. x Depth) (in.)	56.2 x 1.5	56.2 x 1.5	56.2 x 3	56.2 x 3	68.0 x 3	68.0 x 3
Nominal Drive Motor Hp	1/2	1/2	1/2	1/2	1/4**	1/4**
<b>SUPPLY/EXHAUST AIR FAN</b>	2...Forward Curved Centrifugal Adjustable Belt Drive Neoprene Pads					
Qty...Type						
Drive Type						
Fan Isolation						
Wheel Dimensions (Diam. x Width)	15 x 15	15 x 15	15 x 15	15 x 15	18 x 18	18 x 18
Nominal Motor Hp	2	3	5	7 1/2	7 1/2	10
<b>FILTERS (optional)</b>	2-in. Pleated — 30% Efficiency					
Type						
Exhaust Air...Qty...Size (L x W x D) (in.)	6....16 x 20 x 2	6....16 x 20 x 2	6....16 x 20 x 2	6....16 x 20 x 2	6....20 x 24 x 2	6....20 x 24 x 2
Outside Air...Qty...Size (L x W x D) (in.)	6....16 x 20 x 2	6....16 x 20 x 2	6....16 x 20 x 2	6....16 x 20 x 2	6....20 x 24 x 2	6....20 x 24 x 2

**LEGEND**

N/A — Not Applicable

\*Add 10 in. to 62M040 units equipped with a preheater.

†Dimensions include outdoor air hoods.

\*\*575-v motors are 1/3 hp.

**Step 4 — Installing ERV Transitions** — When coupling ERV units with Carrier rooftop units an ERV transition is required to link the ERV unit and the Carrier rooftop unit together.

**ERV UNIT COUPLED WITH A 3 to 12<sup>1</sup>/<sub>2</sub> TON HVAC UNIT** — Complete the following steps to install a transition to a 3 to 12<sup>1</sup>/<sub>2</sub> ton rooftop unit.

1. Remove the HVAC unit filter door and set aside for later use.
2. Remove the panel shipped on the HVAC unit covering the return air chamber. This panel can be discarded.
3. The 62M ERV transition for 3 to 12<sup>1</sup>/<sub>2</sub> ton rooftop units includes a replacement panel to cover the return opening. Install the replacement panel, with hood scoop attached, onto the HVAC unit, over the return air chamber. Screw in place. The return/exhaust scoop will cover part of the return air opening in the HVAC unit.

**NOTE:** The standard transition does not seal tight around the return air opening on the HVAC unit. This allows for some air to flow back to the HVAC unit and some to be drawn back through the ERV unit.

4. Slide the transition between the ERV unit and the HVAC unit. Refer to Fig. 17-44 to orient the transition. Line up the transition so that it covers the openings in the HVAC unit and the ERV unit. The divider in the transition must separate the supply and return openings in the ERV unit. Screw the mating flanges of the transition to the ERV unit through pre-punched holes. Caulk the seams watertight. Screw the mating flanges on the other side of the transition to the new return air cover panel on the HVAC unit. Caulk seams watertight.
5. On most models the filter access door shipped with the HVAC unit will be reinstalled above the transition.
6. The transition includes a balancing damper to allow for the desired separation of the return/exhaust air between the ERV and HVAC units. This damper has a manual adjustment. During balancing, this damper will be adjusted to achieve desired exhaust cfm. The balancing damper can be accessed through a separate door in the transition or through the HVAC unit's filter access door. See Fig. 17-44.

## Step 5 — Make Electrical Connections

### **WARNING**

Prior to performing service or maintenance operations on the ERV unit, turn off and disconnect all power switches to the unit. Be aware that there may be more than one disconnect switch. Electrical shock could cause serious personal injury or death.

**IMPORTANT:** Only trained, qualified installers and service technicians should install, wire, start-up and service equipment.

**POWER SUPPLY** — The electrical characteristics of the available power supply must agree with the unit nameplate rating. Supply voltage must be within the limits shown. See Tables 2 and 3 for electrical and configuration data.

**ELECTRICAL CONNECTIONS** — The ERV unit must have its own electrical disconnect box. If the disconnect option has not been ordered from the factory, it must be field supplied and installed per local codes. See Tables 2 and 3.

If the ERV unit has an electric pre-heater factory installed, it will be wired through the ERV unit disconnect.

**NOTE:** Most ERV units have electrical interlock safety switches on the access doors, which will not allow the ERV unit to operate if either of the access doors are opened.

**Low Voltage Wiring** — Wire low voltage per diagrams. For coupled applications, there will be a brown and black wire in the exhaust chamber, which must be tied into the HVAC unit's indoor fan so that when the indoor fan is activated, the ERV unit will be activated.

**48/50TJ, HJ 3 to 12<sup>1</sup>/<sub>2</sub> Ton Rooftop Units with Economizers** — The brown and black wires can be plugged into the economizer jumper plug on the HVAC unit's economizer harness. Insert the brown wire from the ERV unit into terminal 4 in the jumper plug and insert the black wire from the ERV unit into terminal 3 in the jumper plug. See Fig. 47.

If the 3 to 12<sup>1</sup>/<sub>2</sub> ton rooftop unit has an economizer installed, the economizer will have an end switch attached to the economizer actuator. The end switch must be wired into the ERV unit as shown in Fig. 48.

For ERV units coupled with units with factory-installed economizers, (48/50TM, HJ 15 to 25 ton units 48/50HG, PG 15 to 25 ton units) the ERV transitions to these rooftop units include an economizer end switch. This switch mounts to the hub of the economizer damper gear as shown in Fig. 49. Set the end switch so that the ERV unit's outside air blower is deactivated during economizer mode.

For stand-alone units, the ERV unit is jumpered from terminals 6 and 8 and 7 and 9, providing for continuous operation. The ERV unit should be connected to an on-off device such as a CO<sub>2</sub> sensor.

**High Voltage Wiring (Fig. 50-53)** — Connect high voltage wiring to the disconnect per Fig. 50, 52 and 53. Check blower rotation direction and adjust if necessary.

**Table 2 — Electrical Data Without VAV Option**

UNIT SIZE 62M	VOLTAGE (V-Ph-Hz)	ERV WHEEL FLA	EXHAUST AND SUPPLY MOTOR		HEATER SIZE (kW)	POWER SUPPLY			PRE-HEATER (Optional) FLA	DISCONNECT (Optional)	
			NEC - FLA	Hp		FLA	MCA	MOCP		Amps	Fuse Size* Amps
040	115-1-60	0.7	3.96	.6	—	9.27	9.90	12.87	—	30	12
					2	26.64	31.64	31.64	17.39	40	30
	230-1-60	0.3	1.74†	.6	—	4.44	4.35	5.66	—	30	5
					2	13.76	16.37	16.37	8.7		15
	208/230-3-60	0.3	1.74†	.6	—	4.11	4.35	5.66	—	30	5
					2	9.66	11.30	11.30	5.03		10
	460-3-60	0.3	1.74†	.6	—	2.34	2.72	4.89	—	30	3
					2	4.85	5.86	7.40	2.51		5
	575-3-60	0.3	1.74†	.6	—	1.87	2.17	3.91	—	30	2
					2	3.75	4.18	6.90	2.01		4
075	115-1-60	0.7	9.8	.5	—	20.69	24.5	31.85	—	40	30
					2	38.08	46.24	49.24	17.39	60	45
	230-1-60	0.3	4.9	.5	5	64.17	78.85	78.85	43.48	100	70
					—	10.46	12.25	15.93	—	30	15
	208/230-3-60	0.3	2.2	.5	2	19.16	23.12	24.62	8.7	30	20
					5	32.2	39.42	39.42	21.74		60
	460-3-60	0.3	1.1	.5	—	5.03	5.50	7.15	—	30	6
					2	10.05	11.78	12.18	5.03		12
	575-3-60	0.3	0.9	.5	5	17.59	21.21	21.21	12.57	30	20
					—	2.53	2.75	3.58	—		4
	460-3-60	0.3	1.1	.5	2	5.04	5.89	6.09	2.51	30	6
					5	8.81	10.60	10.60	6.28		10
	575-3-60	0.3	0.9	.5	—	2.10	2.25	2.93	—	30	3
					2	4.11	4.76	4.94	2.01		5
460-3-60	0.3	1.1	.5	5	7.13	8.53	8.53	5.03	30	8	
				—	33.09	40.00	52.00	—		60	50
120	115-1-60	0.7	16	1	2	50.48	61.74	69.39	17.39	80	60
					5	76.57	94.35	95.48	43.48	200	90
	230-1-60	0.3	8	1	—	16.66	20.00	26.00	—	30	25
					2	25.36	30.87	34.70	8.70	40	30
	208/230-3-60	0.3	4.2	1	5	38.40	47.17	47.74	21.74	60	45
					—	9.03	10.50	13.65	—	30	12
	460-3-60	0.3	2.1	1	5	14.05	16.78	18.68	5.03	30	18
					8	21.59	26.21	26.22	12.57	40	25
	575-3-60	0.3	1.7	1	—	4.53	5.25	6.83	—	30	6
					2	7.04	8.39	9.34	2.51		8
	460-3-60	0.3	2.1	1	5	10.81	13.10	13.11	6.28	30	12
					—	3.70	4.25	5.53	—		5
	575-3-60	0.3	1.7	1	2	5.71	6.76	7.54	2.01	30	6
					5	8.73	10.53	10.55	5.03		10
170	230-1-60	0.6	8	1	—	16.93	20.00	26.00	—	30	25
					5	38.67	47.17	47.74	21.74	60	45
	208/230-3-60	0.6	4.2	1	8	51.71	63.48	63.48	34.78	80	60
					10	60.41	74.35	74.35	43.48	100	70
	460-3-60	0.6	2.1	1	—	9.33	10.50	13.65	—	30	12
					5	21.90	26.21	26.22	12.57	40	25
	575-3-60	0.6	1.7	1	8	29.44	35.63	35.63	20.11	60	35
					10	34.46	41.91	41.91	25.13	60	40
	460-3-60	0.6	2.1	1	—	4.69	5.25	6.83	—	30	6
					5	10.97	13.10	13.11	6.28	30	12
	575-3-60	0.6	1.7	1	8	14.74	17.82	17.82	10.05	30	18
					10	17.26	20.96	20.96	12.57	30	20
	460-3-60	0.6	2.1	1	—	3.88	4.25	5.53	—	30	5
					5	8.90	10.53	10.55	5.03	30	10
575-3-60	0.6	1.7	1	8	11.92	14.30	14.30	8.04	30	12	
				10	13.93	16.82	16.82	10.05	30	15	

**LEGEND**

- ERV — Energy Recovery Ventilator
- FLA — Full Load Amps
- Hp — Horsepower
- MCA — Minimum Circuit Amps
- MOCP — Maximum Overcurrent Protection
- NEC — National Electric Code
- N/A — Not Applicable

\*Fused disconnect only.

†Exhaust and supply fan motors are 230-1-60.





**Table 2 — Electrical Data Without VAV Option (cont)**

UNIT SIZE 62M	VOLTAGE (V-Ph-Hz)	ERV WHEEL FLA	EXHAUST AND SUPPLY MOTOR		HEATER SIZE (kW)	POWER SUPPLY			PRE-HEATER (Optional) FLA	DISCONNECT (Optional)	
			NEC - FLA	Hp		FLA	MCA	MOCPP		Amps	Fuse Size* Amps
225	208/230-3-60	0.6	6.8	2	—	14.53	17.00	22.10	—	30	20
					5	27.10	32.71	34.67	12.57	40	30
					8	34.64	42.13	42.21	20.11	60	40
					10	39.66	48.41	48.41	25.13	60	45
	460-3-60		—		7.29	8.50	11.05	—	30	10	
			5		13.57	16.35	17.33	6.28	30	15	
			8		17.34	21.07	21.10	10.05	30	20	
			10		19.86	24.21	24.21	12.57	30	20	
	575-3-60		—		5.88	6.75	8.78	—	30	8	
			5		10.90	13.03	13.80	5.03	30	12	
			8		13.92	16.80	16.82	8.04	30	15	
			10		15.93	19.32	19.32	10.05	30	18	
285	208/230-3-60	0.6	6.8	2	—	14.53	17.00	22.10	—	30	20
					5	27.10	32.71	34.67	12.57	40	30
					8	34.64	42.13	42.21	20.11	60	40
					10	39.66	48.41	48.41	25.13	60	45
	460-3-60		—		7.29	8.50	11.05	—	30	10	
			5		13.57	16.35	17.33	6.28		15	
			8		17.34	21.07	21.10	10.05		20	
			10		19.86	24.21	24.21	12.57		8	
	575-3-60		—		5.88	6.75	8.78	—	30	12	
			5		10.90	13.03	13.80	5.03		15	
			8		13.92	16.80	16.82	8.04		18	
			10		15.93	19.32	19.32	10.05			
330	208/230-3-60	1.2	6.8	2	—	15.13	18.50	23.30	—	30	20
					8	35.24	43.63	43.63	20.11	60	40
					10	40.26	49.91	49.91	25.13	80	45
					15	52.83	65.62	65.62	37.70	80	60
	460-3-60		—		7.62	10.00	12.25	—	30	12	
			8		17.67	22.57	22.57	10.05		20	
			10		20.18	25.71	25.71	12.57		25	
			15		26.46	33.56	33.56	18.85		30	
	575-3-60		—		6.05	8.25	9.98	—	30	8	
			8		14.09	18.30	18.30	8.04		18	
			10		16.10	20.82	20.82	10.05		20	
			15		21.13	27.10	27.10	15.08		25	
430	208/230-3-60	1.2	9.6	3	—	20.73	25.50	32.40	—	40	30
					8	40.84	50.63	52.51	20.11	80	50
					10	45.86	56.91	57.53	25.13	100	70
					15	58.43	72.62	72.62	37.70	100	70
	460-3-60		—		10.42	13.50	16.80	—	40	30	
			8		20.47	26.07	26.85	10.05		15	
			10		22.98	29.21	29.37	12.57		25	
			15		29.26	37.06	37.06	18.85		35	
	575-3-60		—		8.45	11.25	13.88	—	30	12	
			8		16.49	21.30	21.92	8.04		20	
			10		18.50	23.82	23.93	10.05			
			15		23.53	30.10	30.10	15.08		40	
550	208/230-3-60	1.2	15.2	5	—	31.93	39.50	50.60	—	60	50
					8	52.04	64.63	70.71	20.11	100	70
					10	57.06	70.91	75.73	25.13	200	80
					15	69.63	86.62	88.30	37.70	200	80
	460-3-60		—		16.02	20.50	25.90	—	60	30	
			8		26.07	33.07	35.95	10.05		25	
			10		28.58	36.21	38.47	12.57		35	
			15		34.86	44.06	44.75	18.85		40	
	575-3-60		—		12.85	16.75	21.03	—	30	20	
			8		20.89	26.80	29.07	8.04		25	
			10		22.90	29.32	31.08	10.05		30	
			15		27.93	35.60	36.10	15.08		35	

**Table 2 — Electrical Data Without VAV Option (cont)**

UNIT SIZE 62M	VOLTAGE (V-Ph-Hz)	ERV WHEEL FLA	EXHAUST AND SUPPLY MOTOR		HEATER SIZE (kW)	POWER SUPPLY			PRE-HEATER (Optional) FLA	DISCONNECT (Optional)					
			NEC - FLA	Hp		FLA	MCA	MOCP		Amps	Fuse Size† Amps				
640	208/230-3-60	1.2	22	7.5	—	45.53	56.50	72.70	—	100	70				
					8	65.64	81.63	92.81	20.11	200	90				
					10	70.66	87.91	97.83	25.13		110				
					15	83.23	103.62	110.40	37.70		35				
					—	22.82	29.00	36.95	—	60	45				
					8	32.87	41.57	47.00	10.05	60	50				
	10		35.38		44.71	49.52	12.57	30							
	15		41.66		52.56	55.80	18.85	35							
	460-3-60		575-3-60		9	9	—	18.65	24.00	30.45	—	40	30		
							8	26.69	34.05	38.49	8.04	60	40		
							10	28.70	36.57	40.50	10.05		45		
	15						33.73	42.85	45.53	15.08	70				
	750	208/230-3-60					2.5	22	—	46.83	58.13	74.00	—	100	70
									10	71.96	89.54	99.13	25.13	200	90
			15		84.53	105.25			111.70	37.70	110				
20			97.09	120.95	124.26	50.26			35						
—			23.36	29.00	36.95	—			60	45					
10			35.93	44.71	49.52	12.57			80	50					
15		42.21	52.56	55.80	18.85	60									
20		48.49	60.41	62.08	25.13	40									
460-3-60		575-3-60	1.4	9	—	19.53		24.25	30.65	—	40	30			
					10	29.58		36.82	40.70	10.05	60	40			
					15	34.61		43.10	45.73	15.08		45			
20					39.64	49.38		50.76	20.11	50					
950					208/230-3-60	2.5	30.8	—	64.46	80.13	102.60	—	200	100	
								10	92.25	114.86	130.39	27.79		125	
		15	106.15	132.23				144.29	41.69	N/A					
	20	120.04	149.60	158.18				55.58	45						
	—	29.36	36.50	46.70				—	60	50					
	10	41.93	52.21	59.27				12.57	80	60					
	15	48.21	60.06	65.55	18.85		70								
	20	54.49	67.91	71.83	25.13		35								
	460-3-60	575-3-60	1.4	11	—		23.53	29.25	37.15	—	60	45			
					10		33.58	41.82	47.20	10.05	80	50			
					15		38.61	48.10	52.23	15.08		50			
	20				43.64		54.38	57.26	20.11						

**LEGEND**

- ERV — Energy Recovery Ventilator
- FLA — Full Load Amps
- Hp — Horsepower
- MCA — Minimum Circuit Amps
- MOCP — Maximum Overcurrent Protection
- NEC — National Electric Code
- N/A — Not Applicable



\*Fused disconnect only.

†Exhaust and supply fan motors are 230-1-60.

**Table 3 — Electrical Data With VAV Option**

UNIT SIZE 62M*	VFD VOLTAGE V-Ph-Hz	ERV WHEEL FLA	VFD CURRENT INPUT VALUE AMP	EXHAUST AND SUPPLY FAN MOTOR		HEATER SIZE (kW)	POWER SUPPLY			PRE-HEATER (Optional) FLA	DISCONNECT (Optional)		
				NEC - FLA	Hp		FLA	MCA	MOCP		Amps	Fuse Size† Amps	
075	115-1-60	0.7	9.2	2.2	0.5	—	19.75	23.00	29.90	—	40	25	
						2	37.14	44.74	47.29	17.39	60	45	
						5	63.23	77.35	77.35	43.48	100	70	
	—	11.05	13.02			16.93	—	30	15				
	2	19.74	23.89			25.62	8.70	60	25				
	5	32.79	40.19			40.19	21.74	60	40				
	230-1-60**	0.3	5.2	2.8	1.1	0.5	—	6.26	7.03	9.14	—	30	8
							2	11.28	13.31	14.17	5.03	60	12
							5	18.82	22.74	22.74	12.57	60	20
	208/230-3-60	0.3	2.8	1.5	0.9	0.5	—	3.24	3.65	4.74	—	30	5
							2	5.76	6.79	7.25	2.51	60	6
							5	9.53	11.50	11.50	6.28	60	10
460-3-60	0.3	1.5	2.1	0.9	0.5	—	4.41	5.13	6.67	—	30	6	
						2	6.42	7.64	8.68	2.01	60	8	
						5	9.43	11.41	11.69	5.03	60	10	
575-3-60	0.3	2.1	0.9	0.9	0.5	—	4.41	5.13	6.67	—	30	6	
						2	6.42	7.64	8.68	2.01	60	8	
						5	9.43	11.41	11.69	5.03	60	10	
120	115-1-60	0.7	16.6	4.2	1	—	34.55	41.50	53.95	—	80	50	
						2	51.94	63.24	71.34	17.39	100	70	
						5	78.03	95.85	97.43	43.48	200	90	
	—	19.80	23.96			31.15	—	40	30				
	2	28.49	34.83			39.84	8.70	60	35				
	5	41.54	51.13			52.88	21.74	80	50				
	230-1-60**	0.3	9.6	5.3	2.1	1	—	11.26	13.28	17.27	—	30	15
							5	16.28	19.56	22.29	5.03	30	20
							8	23.82	28.99	29.83	12.57	40	25
	208/230-3-60	0.3	5.3	2.6	1.7	1	—	5.53	6.51	8.46	—	30	8
							2	8.05	9.65	10.98	2.51	60	10
							5	11.82	14.36	14.75	6.28	60	12
460-3-60	0.3	2.6	2.1	1.7	1	—	4.41	5.13	6.67	—	30	6	
						2	6.42	7.64	8.68	2.01	60	8	
						5	9.43	11.41	11.69	5.03	60	10	
575-3-60	0.3	2.1	2.1	1.7	1	—	4.41	5.13	6.67	—	30	6	
						2	6.42	7.64	8.68	2.01	60	8	
						5	9.43	11.41	11.69	5.03	60	10	
170	230-1-60**	0.6	9.6	4.2	1	—	20.10	23.96	31.15	—	40	30	
						5	41.84	51.13	52.88	21.74	80	50	
						8	54.88	67.44	67.44	34.98	80	60	
	10	63.57	78.31			78.31	43.48	100	70				
	—	11.56	13.28			17.27	—	30	15				
	5	24.12	28.99			29.83	12.57	40	25				
	208/230-3-60	0.6	5.3	2.6	2.1	1	8	31.66	38.41	38.41	20.11	60	35
							10	36.69	44.70	44.70	25.13	60	40
							—	5.70	6.51	8.46	—	30	8
	460-3-60	0.6	2.6	2.1	1.7	1	5	11.98	14.36	14.75	6.28	30	12
							8	15.75	19.08	19.08	10.05	60	17.5
							10	18.26	22.22	22.22	12.57	60	20
575-3-60	0.6	2.1	2.1	1.7	1	—	4.58	5.13	6.67	—	30	6	
						5	9.61	11.41	11.69	5.03	60	10	
						8	12.62	15.18	15.18	8.04	60	15	
208/230-3-60	0.6	8.2	6.8	3.4	2	10	14.63	17.69	17.69	10.05	60	17.5	
						—	17.39	20.57	26.74	—	40	25	
						5	29.95	36.28	39.31	12.57	60	35	
460-3-60	0.6	4.2	3.4	2.7	2	8	37.49	45.70	46.85	20.11	60	45	
						10	42.52	51.99	51.99	25.13	60	50	
						—	8.82	10.42	13.54	—	30	12	
575-3-60	0.6	3.6	2.7	2.7	2	5	15.11	18.27	19.82	6.28	40	17.5	
						8	18.88	22.98	23.59	10.05	40	20	
						10	21.39	26.12	26.12	12.57	40	25	
208/230-3-60	0.6	8.2	6.8	3.4	2	—	7.66	8.97	11.66	—	30	10	
						5	12.68	15.26	16.69	5.03	60	15	
						8	15.70	19.03	19.71	8.04	60	17.5	
460-3-60	0.6	4.2	3.4	2.7	2	10	17.71	21.54	21.72	10.05	60	20	
						—	17.39	20.57	26.74	—	40	25	
						5	29.95	36.28	39.31	12.57	60	35	
575-3-60	0.6	3.6	2.7	2.7	2	8	37.49	45.70	46.85	20.11	60	45	
						10	42.52	51.99	51.99	25.13	60	50	
						—	8.82	10.42	13.54	—	30	12	

**Table 3 — Electrical Data With VAV Option (cont)**

UNIT SIZE 62M*	VFD VOLTAGE V-Ph-Hz	ERV WHEEL FLA	VFD CURRENT INPUT VALUE AMP	EXHAUST AND SUPPLY FAN MOTOR		HEATER SIZE (kW)	POWER SUPPLY			PRE-HEATER (Optional) FLA	DISCONNECT (Optional)	
				NEC - FLA	Hp		FLA	MCA	MOCP		Amps	Fuse Size† Amps
285	208/230-3-60	0.6	8.2	6.8	2	—	17.39	20.57	26.74	—	40	25
						5	29.95	36.28	39.31	12.57	60	35
						8	37.49	45.70	46.85	20.11		45
						10	42.52	51.99	51.99	25.13	50	
	460-3-60		—	8.82		10.42	13.54	—	30	12		
			5	15.11		18.27	19.82	6.28		17.5		
			8	18.88		22.98	23.59	10.05	20			
			10	21.39		26.12	26.12	12.57	40	25		
	575-3-60	—	7.66	8.97	11.66	—	30	10				
		5	12.68	15.26	16.69	5.03		15				
		8	15.70	19.03	19.71	8.04	17.5					
		10	17.71	21.54	21.72	10.05	20					
330	208/230-3-60	1.2	8.2	6.8	2	—	17.99	20.57	26.74	—	40	25
						8	38.09	45.70	46.85	20.11	60	45
						10	43.12	51.99	51.99	25.13		50
						15	55.69	67.70	67.70	37.70	80	60
	460-3-60		—	9.15		10.42	13.54	—	30	12		
			8	19.20		22.98	23.59	10.05		20		
			10	21.71		26.12	26.12	12.57	40	25		
			15	28.00		33.98	33.98	18.85	30	30		
	575-3-60	—	7.83	8.97	11.66	—	30	10				
		8	15.87	19.03	19.71	8.04		18				
		10	17.88	21.54	21.72	10.05	20					
		15	22.91	27.82	27.82	15.08	40	25				
430	208/230-3-60	1.2	11.3	9.6	3	—	24.03	28.13	36.56	—	60	35
						8	44.14	53.26	56.67	20.11	80	50
						10	49.16	59.54	61.69	25.13		60
						15	61.73	75.25	75.25	37.70	100	70
	460-3-60		—	12.07		14.06	18.28	—	40	30		
			8	22.12		26.63	28.33	10.05		25		
			10	24.63		29.77	30.85	12.57	30			
			15	30.91		37.62	37.62	18.85	60	35		
	575-3-60	—	10.29	12.05	15.66	—	30	15				
		8	18.33	22.10	23.71	8.04		20				
		10	20.34	24.61	25.72	10.05	25					
		15	25.37	30.90	30.90	15.08	40	30				
550	208/230-3-60	1.2	17.8	15.2	5	—	37.16	44.53	57.89	—	80	50
						8	57.26	69.66	78.00	20.11	100	70
						10	62.29	75.95	83.02	25.13		80
						15	74.85	91.65	95.59	37.70	200	90
	460-3-60		—	18.73		22.40	29.11	—	60	40		
			8	28.78		34.96	39.17	10.05		35		
			10	31.30		38.10	41.68	12.57	40			
			15	37.58		45.96	47.96	18.85	45			
	575-3-60	—	15.83	18.97	24.66	—	40	30				
		8	23.87	29.02	32.70	8.04		30				
		10	25.88	31.54	34.71	10.05	30					
		15	30.91	37.82	39.74	15.08	60	35				

**LEGEND**

- ERV — Energy Recovery Ventilator
- FLA — Full Load Amps
- Hp — Horsepower
- MCA — Minimum Circuit Amps
- MOCP — Maximum Overcurrent Protection
- NEC — National Electric Code
- N/A — Not Applicable
- VFD — Variable Frequency Drive



\*The VAV option is not available on 62M040 units.  
 †Fused disconnect only.  
 \*\*Exhaust and supply fan motors are 230-3-60.

**Table 3 — Electrical Data With VAV Option (cont)**

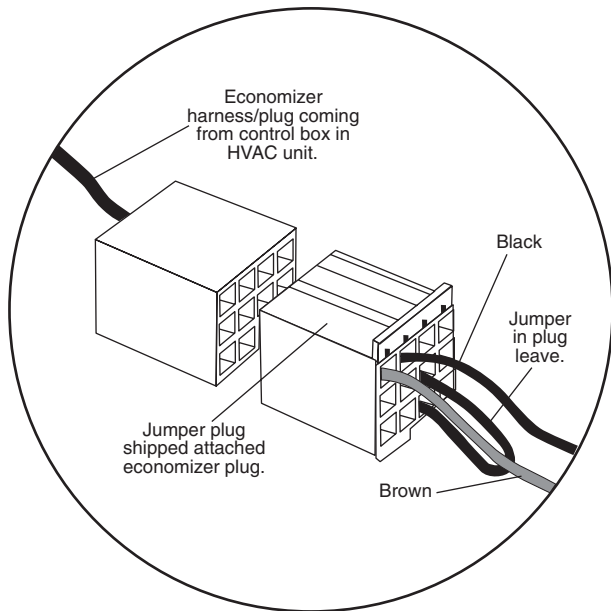
UNIT SIZE 62M*	VFD VOLTAGE V-Ph-Hz	ERV WHEEL FLA	VFD CURRENT INPUT VALUE AMP	EXHAUST AND SUPPLY FAN MOTOR		HEATER SIZE (kW)	POWER SUPPLY			PRE- HEATER (Optional) FLA	DISCONNECT (Optional)	
				NEC - FLA	Hp		FLA	MCA	MOCP		Amps	Fuse Size† Amps
640	208/230-3-60	1.2	26	22	7.5	—	53.61	65.10	84.64	—	100	80
						8	73.72	90.24	104.74	20.11	200	100
						10	78.75	96.52	109.77	25.13	200	100
						15	91.31	112.23	122.33	37.70	200	110
	460-3-60		—	26.65		32.29	41.98	—	60	40		
			8	36.70		44.86	52.03	10.05	60	50		
			10	39.21		48.00	54.55	12.57	80	50		
			15	45.50		55.85	60.83	18.85	80	60		
	575-3-60		—	23.62		28.71	37.33	—	60	35		
			8	31.66		38.76	45.37	8.04	60	45		
			10	33.67		41.28	47.38	10.05	60	45		
			15	38.70		47.56	52.40	15.08	80	50		
750	208/230-3-60	2.5	26	22	7.5	—	54.91	65.10	84.64	—	100	80
						10	80.05	96.52	109.77	25.13	200	100
						15	92.61	112.23	122.33	37.70	200	110
						20	105.18	127.93	134.90	50.26	200	125
	460-3-60		—	27.20		32.29	41.98	—	60	40		
			10	39.76		48.00	54.55	12.57	80	50		
			15	46.05		55.85	60.83	18.85	80	60		
			20	52.33		63.71	67.11	25.13	80	60		
	575-3-60		—	24.50		28.71	37.33	—	60	35		
			10	34.55		41.28	47.38	10.05	60	45		
			15	39.58		47.56	52.40	15.08	80	50		
			20	44.61		53.84	57.43	20.11	80	50		
950	208/230-3-60	2.5	34	30.8	10	—	70.86	85.00	110.50	—	200	110
						10	98.65	119.74	138.29	27.79	200	125
						15	112.55	137.11	152.19	41.69	200	N/A
						20	126.44	154.48	166.08	55.58	200	N/A
	460-3-60		—	34.28		41.15	53.49	—	80	50		
			10	46.85		56.85	66.06	12.57	80	60		
			15	53.13		64.71	72.34	18.85	80	70		
			20	59.41		72.56	78.62	25.13	100	70		
	575-3-60		—	29.63		35.12	45.66	—	60	45		
			10	39.68		47.69	55.71	10.05	80	50		
			15	44.71		53.97	60.74	15.08	80	60		
			20	49.73		60.25	65.76	20.11	80	60		

**LEGEND**

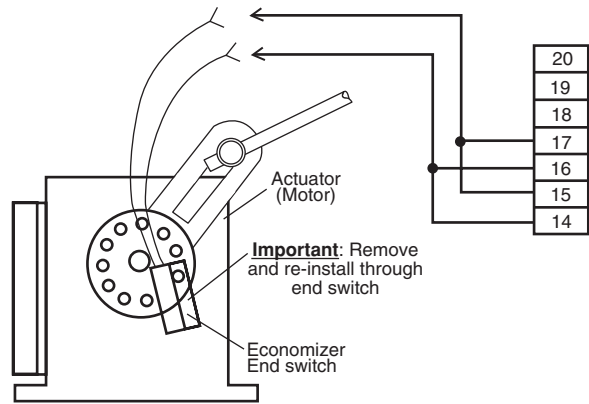
- ERV — Energy Recovery Ventilator
- FLA — Full Load Amps
- Hp — Horsepower
- MCA — Minimum Circuit Amps
- MOCP — Maximum Overcurrent Protection
- NEC — National Electric Code
- N/A — Not Applicable
- VFD — Variable Frequency Drive



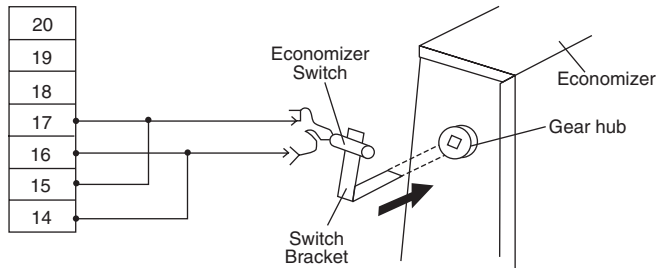
\*The VAV option is not available on 62M040 units.  
 †Fused disconnect only.  
 \*\*Exhaust and supply fan motors are 230-3-60.



**Fig. 47 — Jumper Plug Detail**



**Fig. 48 — Economizer End Switch Wiring**



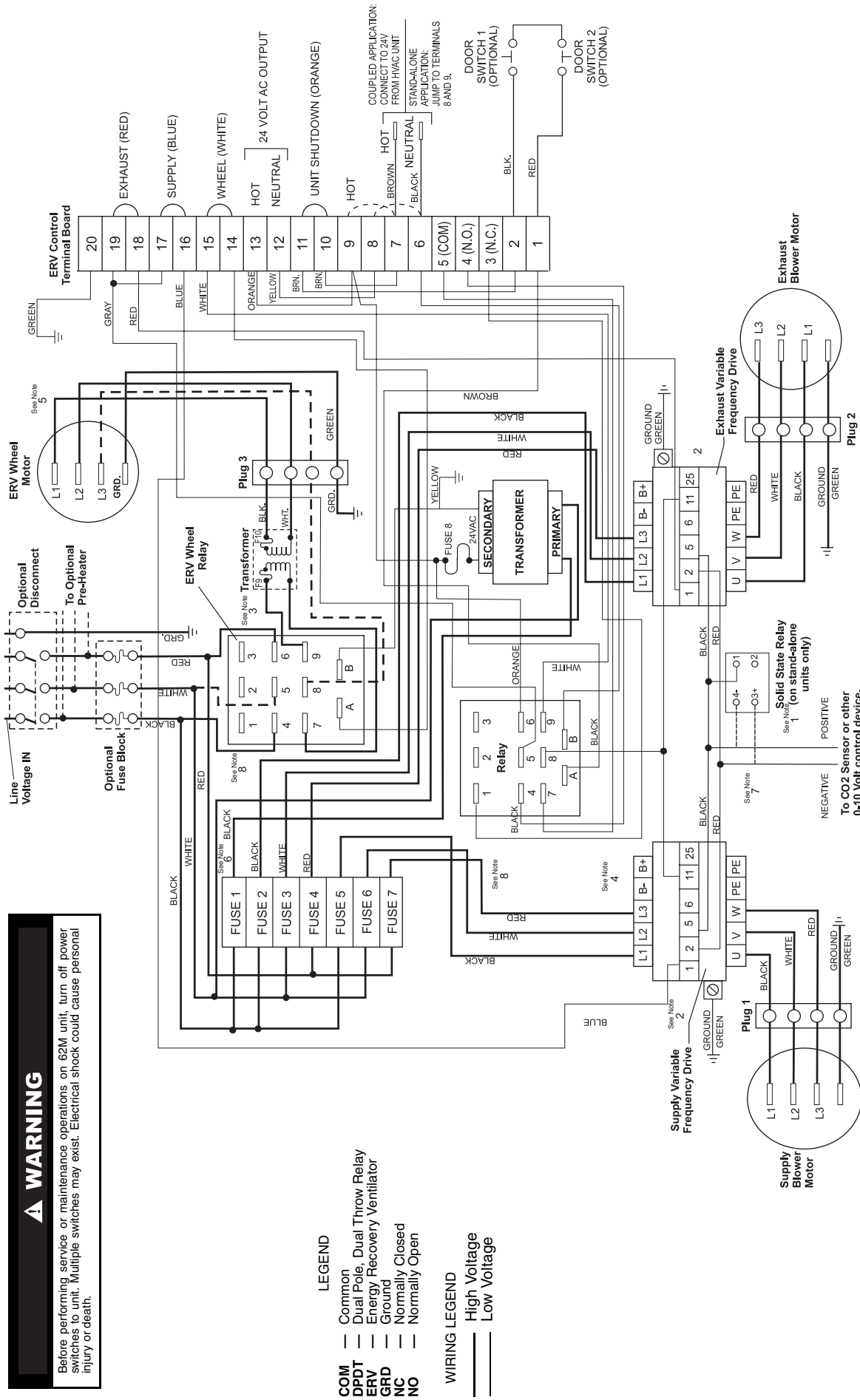
**Fig. 49 — Economizer Switch Wiring**







**WARNING**  
 Before performing service or maintenance operations on 62M unit, turn off power switches to unit. Multiple switches may exist. Electrical shock could cause personal injury or death.



**LEGEND**  
 COM — Common  
 DPDT — Dual Pole, Dual Throw Relay  
 ERV — Energy Recovery Ventilator  
 GRD — Ground  
 NC — Normally Closed  
 NO — Normally Open

**WIRING LEGEND**  
 High Voltage  
 Low Voltage

- NOTES:**
- When the 62M unit is used in a stand-alone application, the solid-state relay will be added to activate ERV at approximately 2 volts. CO<sub>2</sub> sensor output signal is sent to relay. Coupled units are activated through HVAC unit.
  - Supply and Exhaust Variable Frequency Drive (VFD) terminals no. 25 and no. 2 can be used as a 4 to 20 mA power control source, if desired.
  - Transformer not necessary on all 62M750,950 units.
  - Variable frequency drives are sensitive to the polarity of a 0 to 10 volt DC control signal. If the control source is acting properly and the voltage variance can be detected on the proper leads of the VFD, reverse the leads and the controller will respond.
  - Three-phase motor on all 62M750,950 units.
  - Color determined by primary voltage: Red — 200 vac, Orange — 230 vac, Black — 460 vac.
  - 0 to 10 volt and 4 to 20 mA inputs are polarity sensitive. Reverse leads if signal fails to update controller.
  - DPDT relay may be substituted. If so, pins 2, 5 and 8 will not exist.

**Fig. 52 — Typical Wiring Schematic, High/Low Voltage with Variable Air Volume Option**

NOTES:  
 1. Thermostat is factory set at -5 degrees. Range is -30 to 100 F.  
 2. Minimum airflow is .05 in. wg.

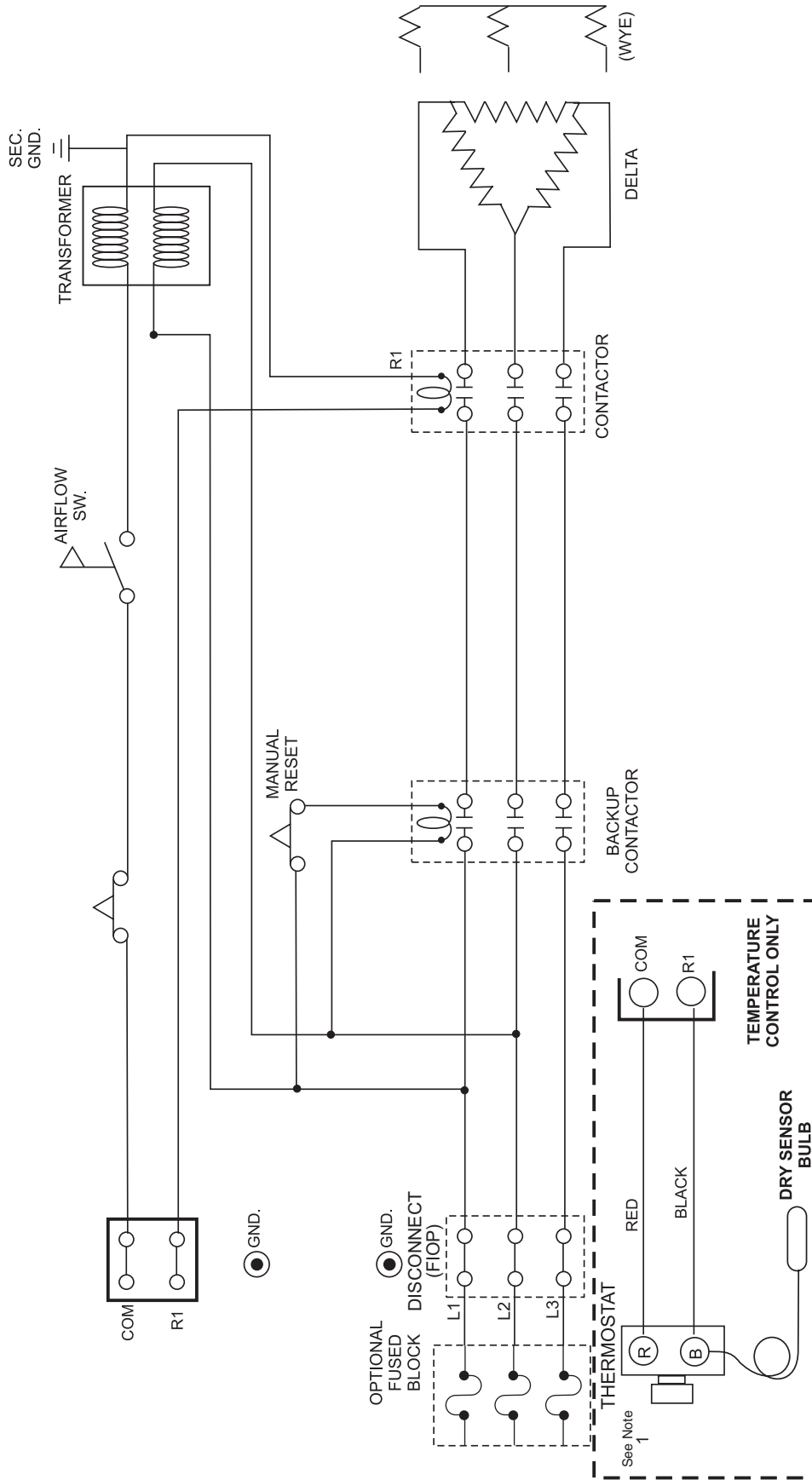


Fig. 53 — Typical Wiring Schematic, Optional Preheat High Voltage and Control Circuits

## START-UP

### ⚠ CAUTION

Do not operate the ERV unit without the filters and bird-screens installed, which prevent foreign objects from entering the unit.

Use the following information and the Start-Up Checklist on page CL-1 to check unit PRIOR to start-up.

**Unit Preparation** — Check that the unit has been installed in accordance with these installation instructions and all applicable codes.

Check all fasteners and set screws for tightness. This is critical for bearings and fan wheels. Also, if dampers are not motorized, check that they open and close without binding.

**Internal Wiring** — Check all electrical connections in the control box. Tighten as required.

**Rain Hoods** — Some ERV units will require the outside air and/or exhaust hood to be field installed. Caulk coupled flanges and screw to ERV unit.

NOTE: Units for indoor applications will not have rain hoods.

The outside air hood will include aluminum water entrainment filters, which should be in place prior to starting the unit.

### Energy Recovery Wheel

**DRIVE BELT** — Turn the energy recovery wheel by hand to verify free operation. Inspect the belt, which drives the energy wheel rotation. Make sure the belt rides smoothly through the pulley and over the wheel rim.

**AIR SEALS** — Check that the air seals, located around the outside of the wheel and across the center, on both sides of wheel, are secure and in good condition. Air seals which are too tight will prevent proper rotation of the energy recovery wheel. Re-check the air seals for tightness.

Air seal clearance may be checked by placing a sheet of paper, like a feeler gage, against the wheel face. To adjust the air seals, loosen all eight seal retaining screws. These screws are located on the bearing support that spans the length of the cassette through the wheel center. Tighten the screws so the air seals tug slightly on the sheet of paper as the wheel is turned.

Replace the access door and apply power. Observe that the wheel rotates freely. If the wheel does not rotate or is binding, remove the cassette and adjust.

**Blower Rotation** — First, hand-rotate the blower to ensure that the wheel is not rubbing against the scroll. If the blower is rotating in the wrong direction, the ERV unit will move some air, but will not perform properly.

To change the rotation, turn the power off and use the following procedure:

- Single-phase units — Rewire the motor per the instructions located on the motor.
- Three-phase units — Interchange any two power leads. This can be done at the motor starter.

**Airflow Settings and Adjustments** — Most ERV units have factory-installed airflow test ports, which allow the balancer of the job to easily measure the static pressure across the ERV wheel, and thus the system airflow cfm levels. The static is measured on both the supply and return sides of the wheel. See Fig. 54-56.

To achieve the highest level of effectiveness, the airflow across the supply and return should be equal.

**FACTORY SETTING** — The ERV unit is factory set to achieve the maximum airflow cfm within the cabinet's range. For example, a 62M170 unit has a range of 1,400 to 2,000 cfm airflow, and when shipped will be setup to achieve the 2,000 cfm airflow level. See Fig. 57-80.

**CURVE SELECTION** — Refer to the fan curve for the ERV unit being used for the application. See Fig. 57-80. Knowing the outside air intake cfm required and the external static pressure on the application, select the fan curve desired. The fan curve will indicate how to set the blower motor pulley to achieve the desired cfm level. If the job requirements are the same as the maximum ERV unit setup, then no blower adjustments are required.

**ADJUST THE ERV BLOWER SPEED** — If jobsite conditions require blower speeds other than the factory setting, then the ERV blower(s) will have to be adjusted. The fan curve will specify the number of turns to be made to the adjustable pulley on the blower motor. See Fig. 57-80.

**Belt Drive Motors** — Check pulley alignment and belt tension prior to set up. To change the speeds of the blowers:

1. Shut off power supply and tag disconnect.
2. Loosen belt tension.
3. Loosen adjustable (movable) pulley flange set screw. See Fig. 81.
4. Screw adjustable pulley side toward the fixed side to increase speed or away from fixed side to decrease speed. Increasing speed increases load on motor. Do not exceed maximum load for motor.
5. Set adjustable pulley side at nearest keyway of pulley hub and tighten set screw. See fan curves for speed change for each turn of the adjustable pulley.

**Aligning Blower and Motor Pulleys** — It is important that the pulleys be exactly in line with one another. See Fig. 82.

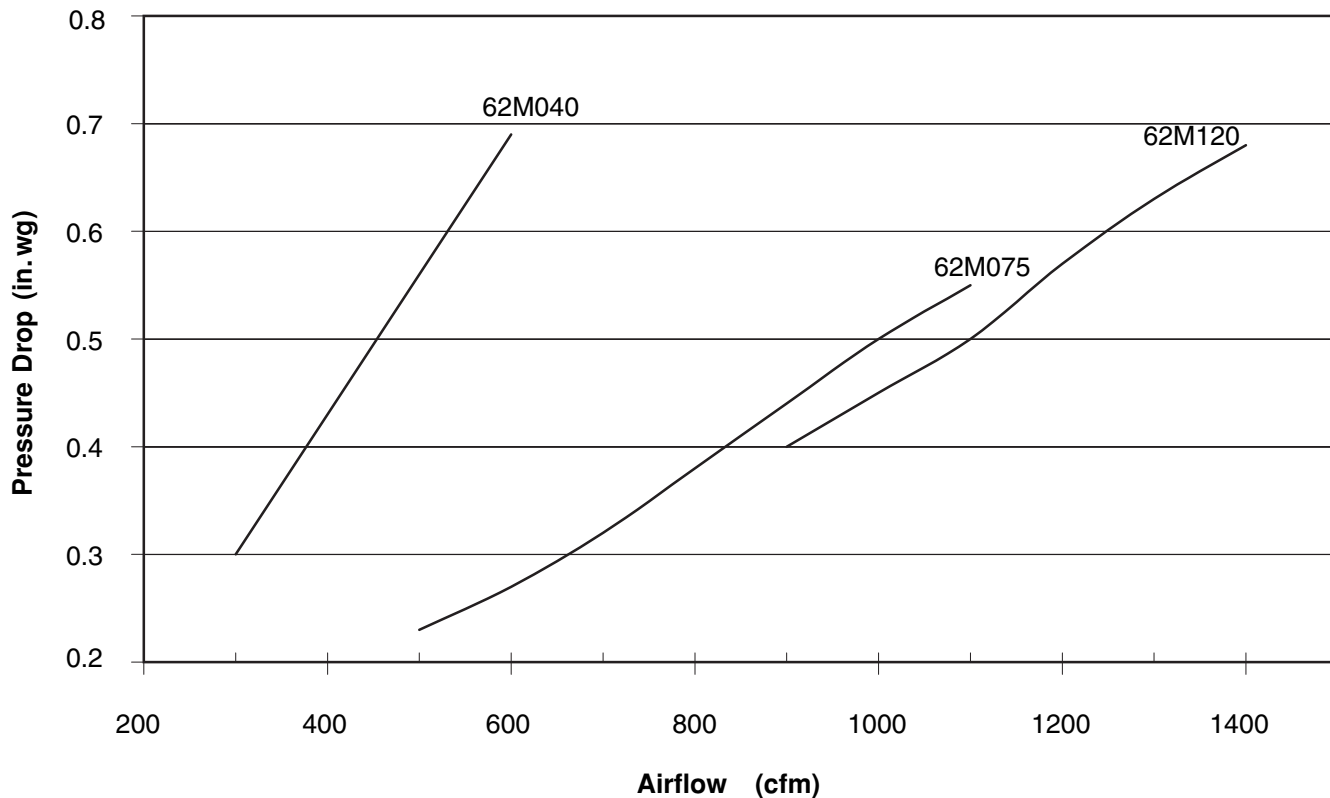
1. Loosen blower pulley set screw.
2. Align pulleys per illustration. Motor and blower shafts must be parallel.
3. Tighten pulley set screws.

**Adjust Belt Tension** — Loosen blower motor mounting nuts, and slide motor mounting plate away from fan scroll for proper belt tension ( $1/2$ -in. deflection with 7 to 10 lb of force.)

**MEASURE MOTOR VOLTAGE, AMPERAGE AND FAN RPM** — Measure and record the input voltage and motor amperage(s). To measure the fan rpm, the blower door will need to be opened. Minimize measurement time because the motor may over-amp with the door removed. Do not operate units with access doors/panels open as the motors will over-load. With the blower door closed, compare measured amps to the motor nameplate full load amps and correct if the ERV unit is over-amping.

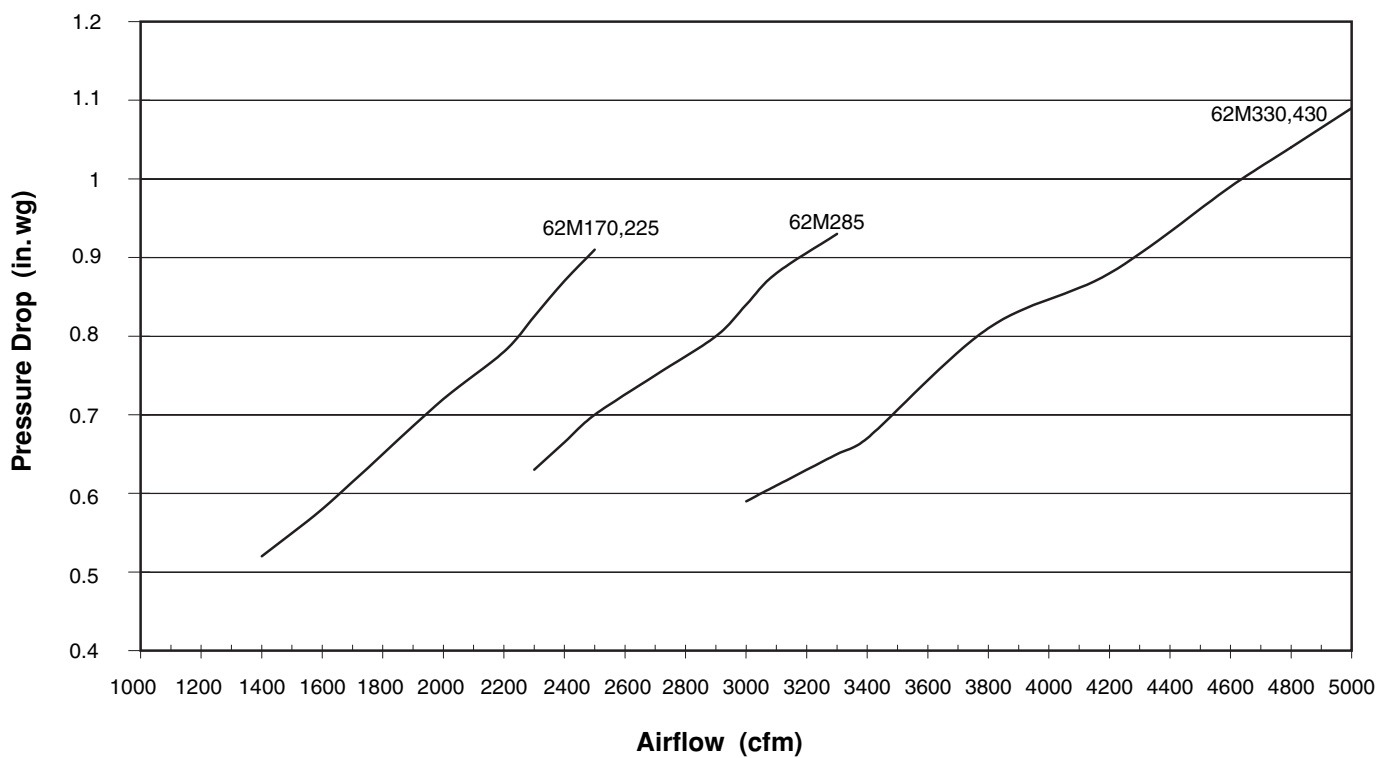
**BELT MAINTENANCE** — Premature belt failures are frequently caused by improper belt tension (either too tight or too loose), or misaligned pulleys. The proper tension for operating a V-belt is the lowest tension at which the belts will not slip at peak load conditions. Check belt tension two weeks after start-up and periodically thereafter. It is very important that the drive pulleys remain in proper alignment after adjustments are made. Misalignment of pulleys will result in premature belt wear, noise, vibration, and power loss. Maintain belts and motors through the provided access panels. Refer to Fig. 82.

*Text continued on page 74.*



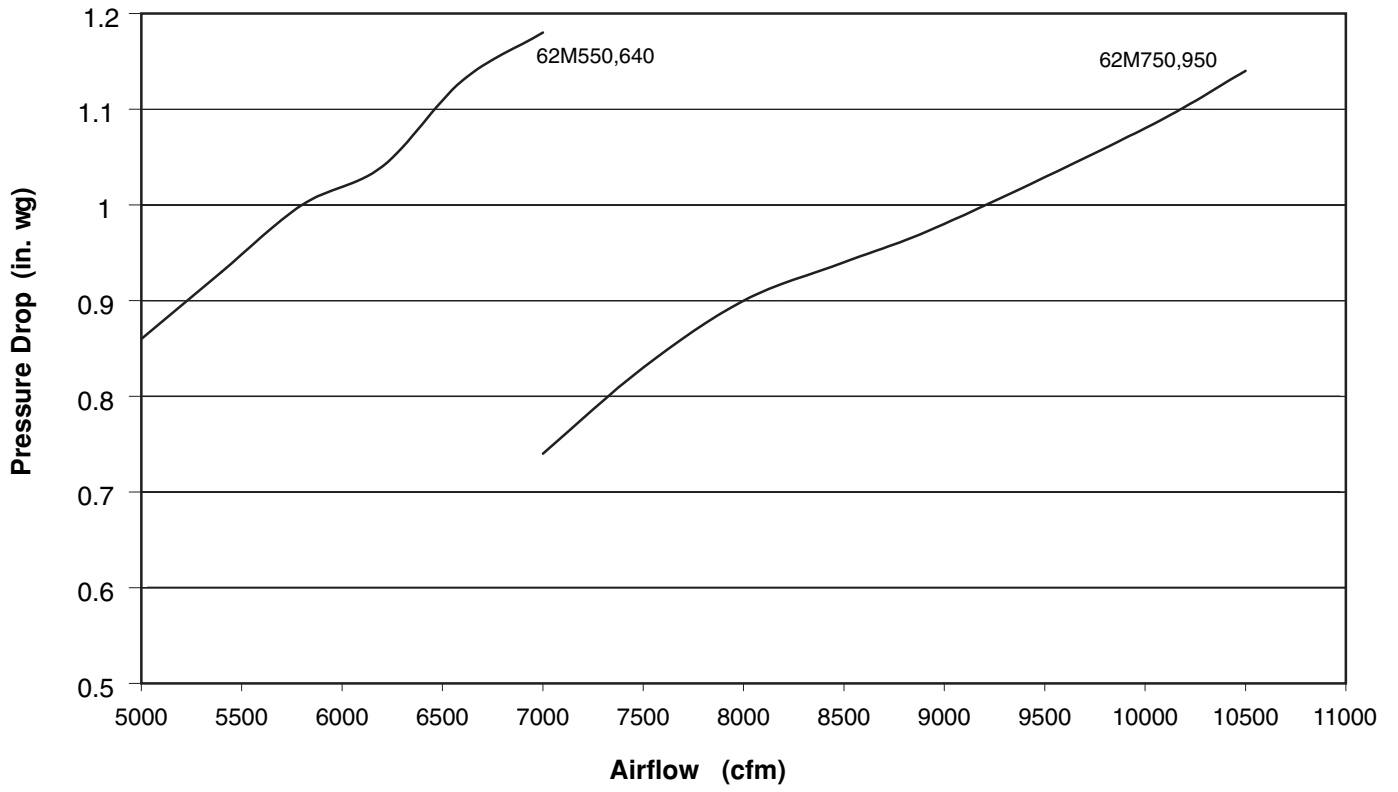
\*Data based on measurements taken using optional airflow test ports.

**Fig. 54 — 62M040-120 ERV Wheel Pressure Drop\***



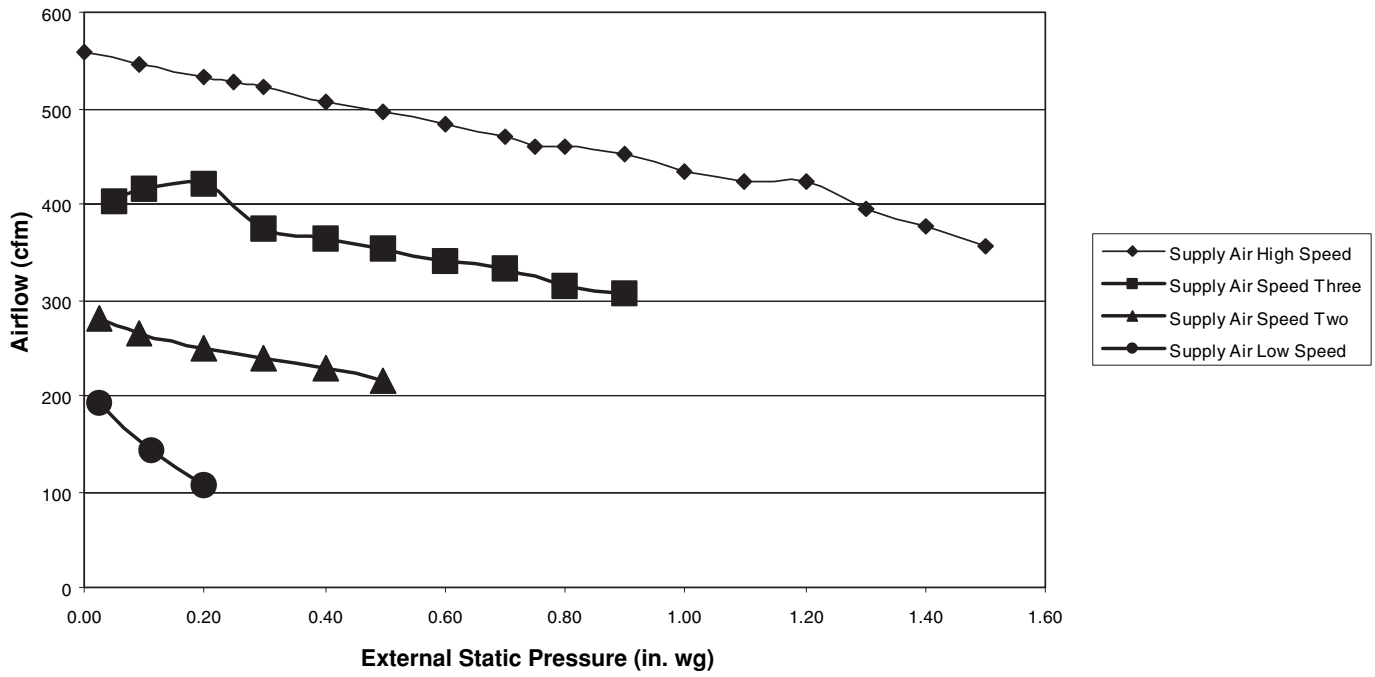
\*Data based on measurements taken using optional airflow test ports.

**Fig. 55 — 62M170-430 ERV Wheel Pressure Drop\***



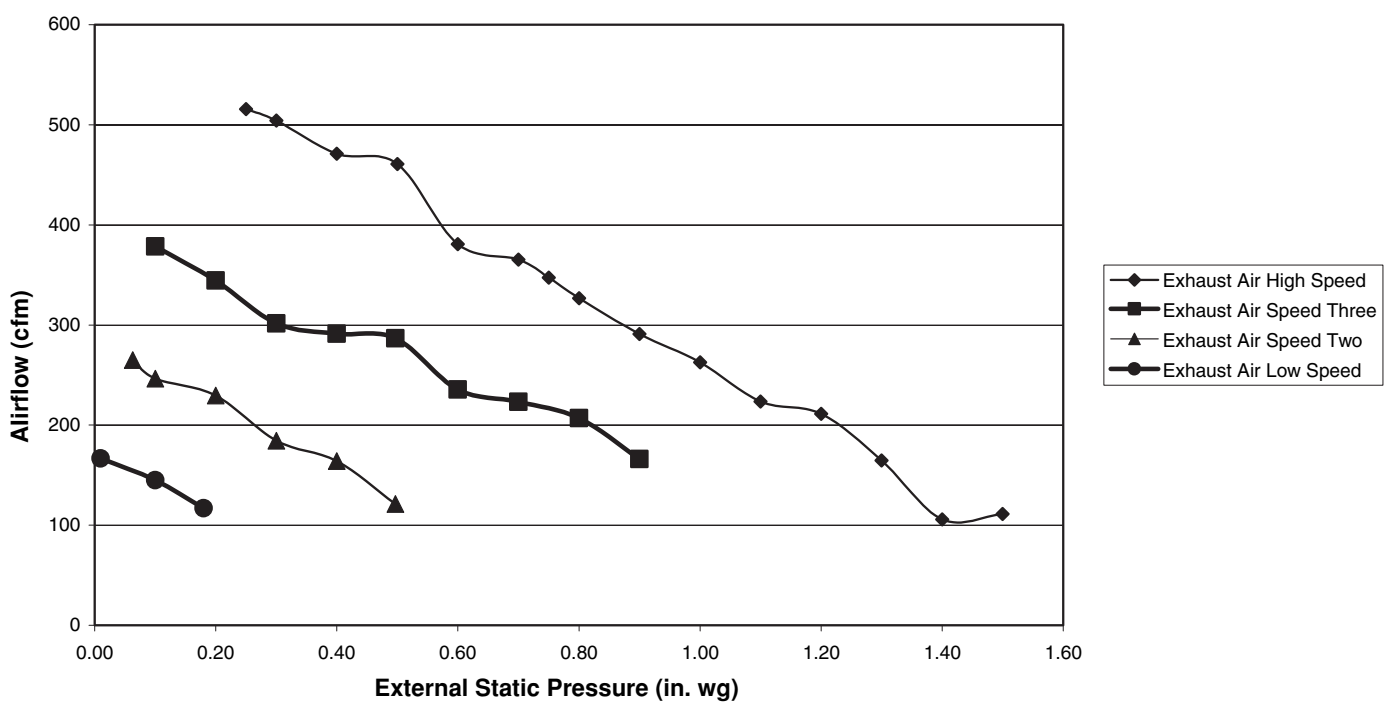
\*Data based on measurements taken using optional airflow test ports.

**Fig. 56 — 62M550-950 ERV Wheel Pressure Drop\* (cont)**



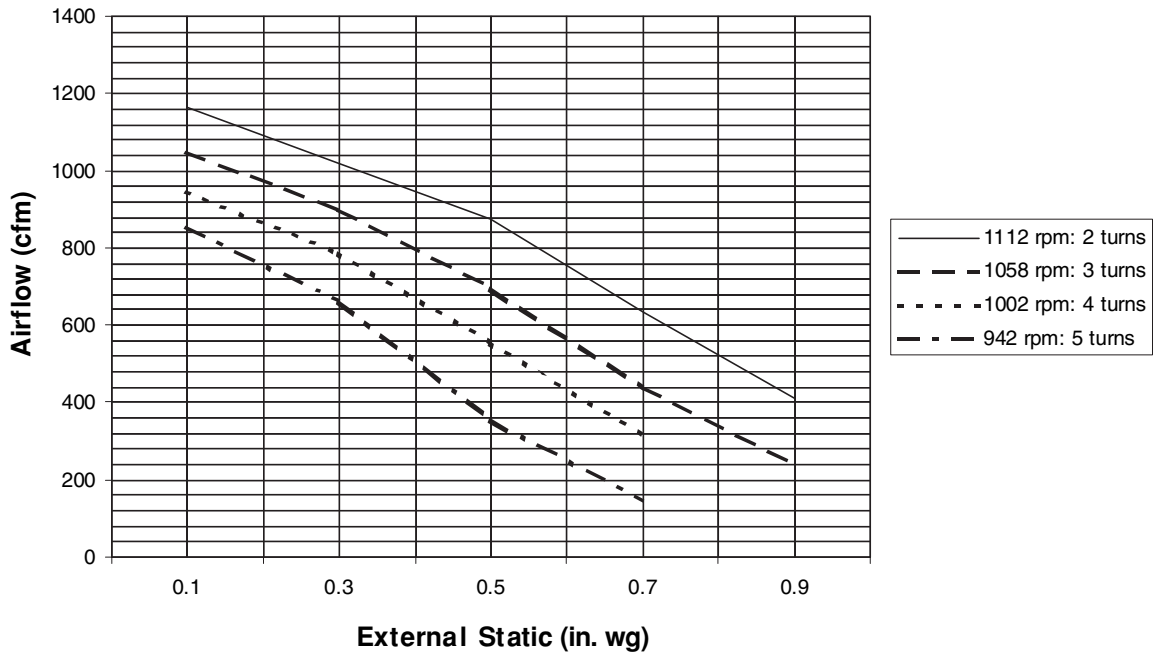
NOTE: Fan data includes pressure drop for 30% efficient 2-in. filters.

**Fig. 57 — 62M040 Supply Air Fan Performance Curves**



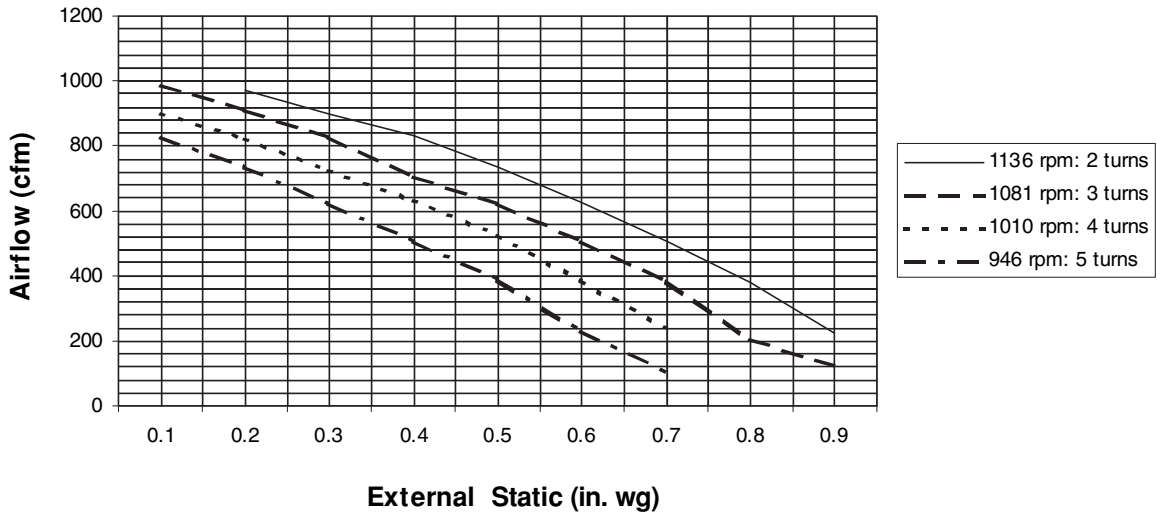
NOTE: Fan data includes pressure drop for 30% efficient 2-in. filters.

**Fig. 58 — 62M040 Exhaust Air Fan Performance Curves**



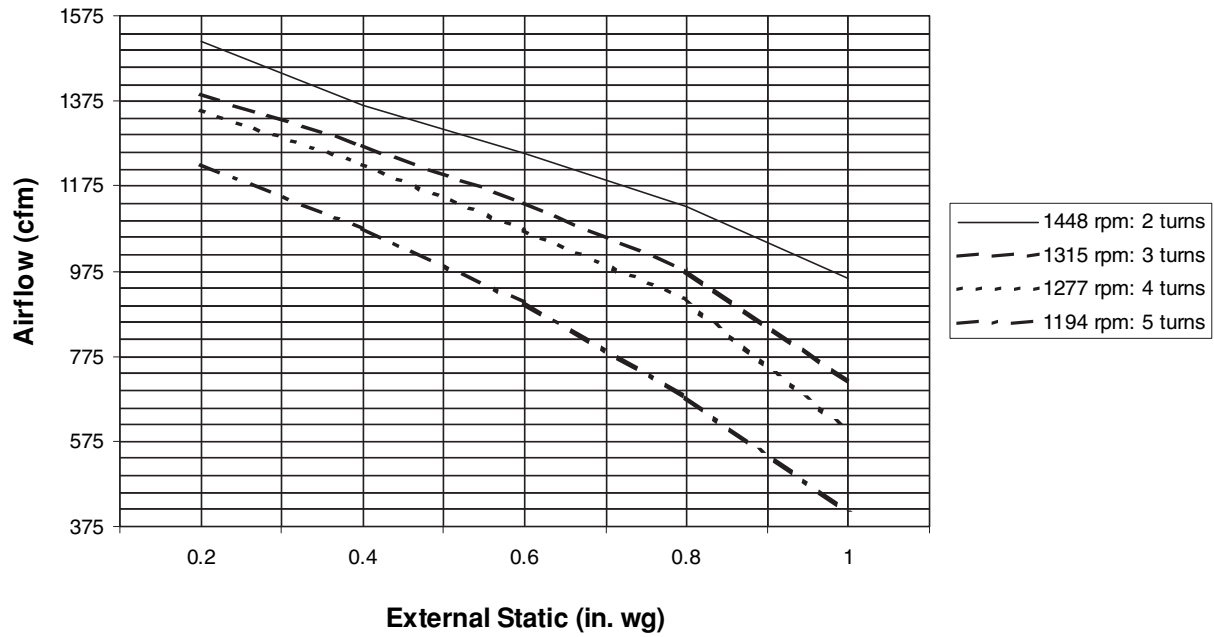
NOTE: Fan data includes pressure drop for 30% efficient 2-in. filters.

**Fig. 59 — 62M075 Supply Air Fan Performance Curves**



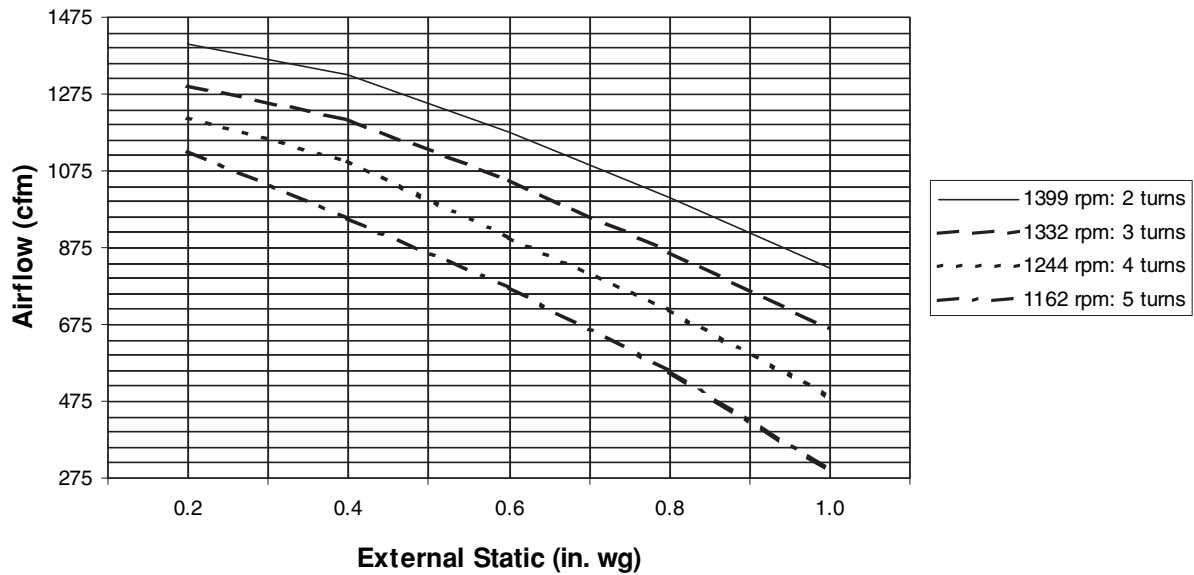
NOTE: Fan data includes pressure drop for 30% efficient 2-in. filters.

**Fig. 60 — 62M075 Exhaust Air Fan Performance Curves**



NOTE: Fan data includes pressure drop for 30% efficient 2-in. filters.

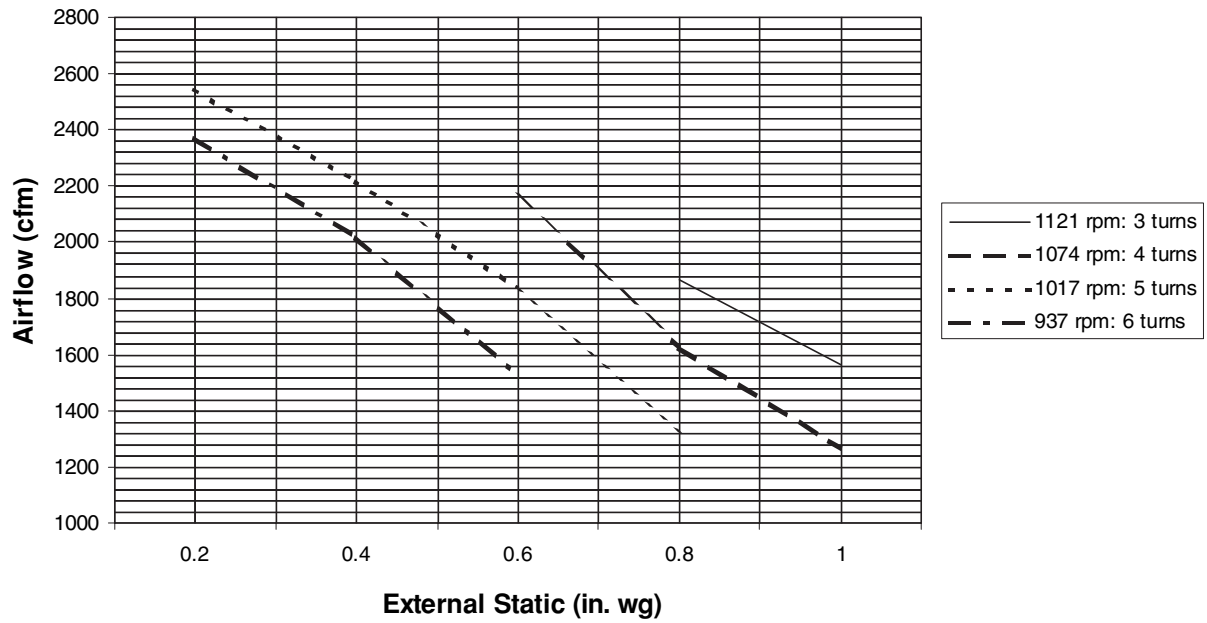
**Fig. 61 — 62M120 Supply Air Fan Performance Curves**



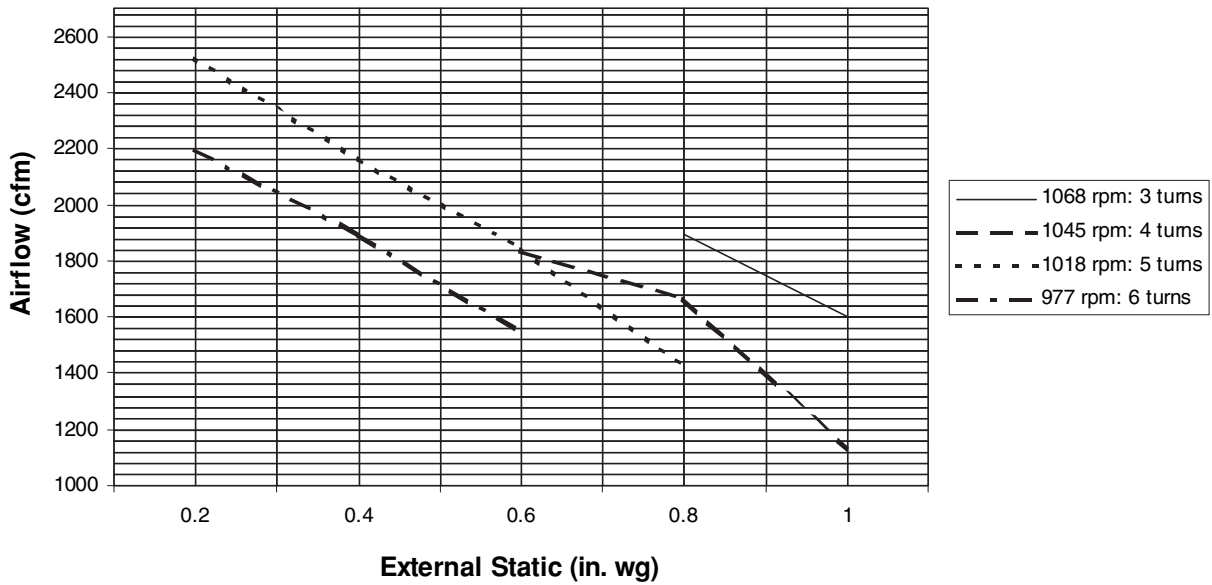
NOTE: Fan data includes pressure drop for 30% efficient 2-in. filters.

**Fig. 62 — 62M120 Exhaust Air Fan Performance Curves**

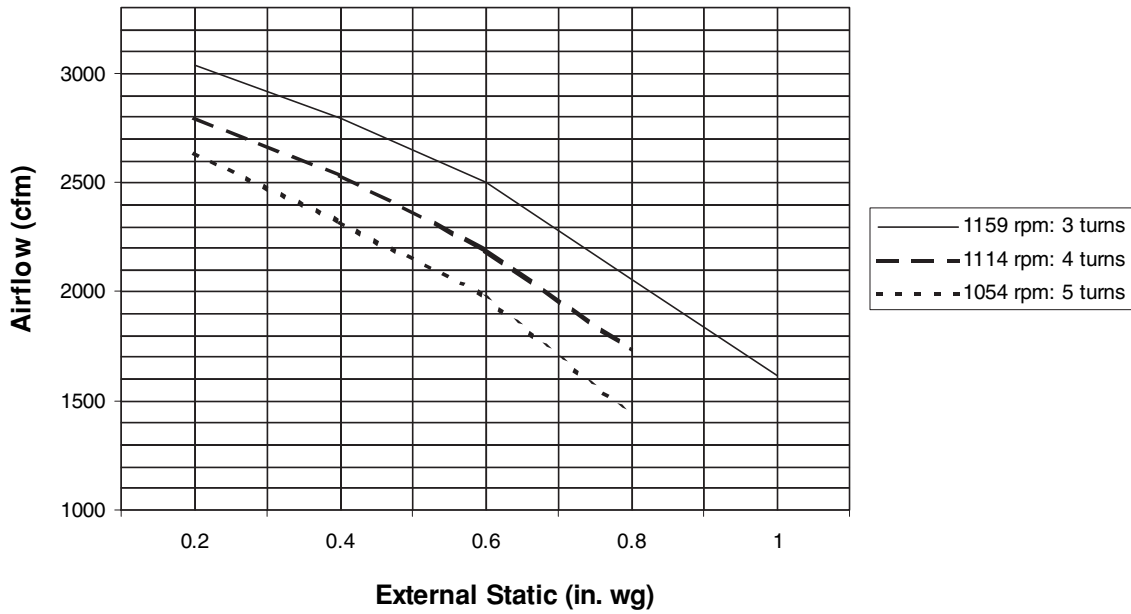




**Fig. 63 — 62M170 Supply Air Fan Performance Curves**

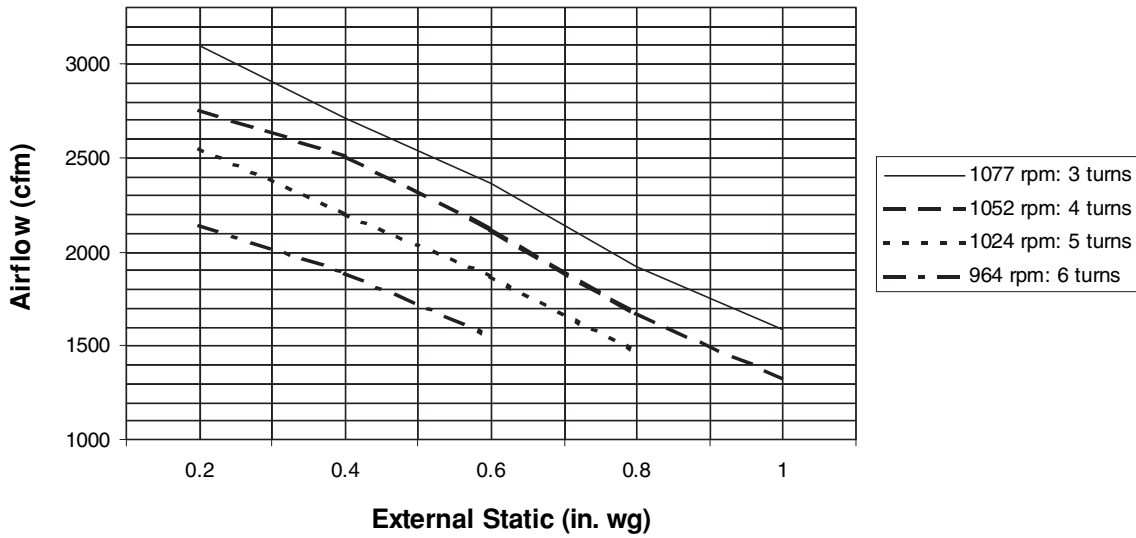


**Fig. 64 — 62M170 Exhaust Air Fan Performance Curves**



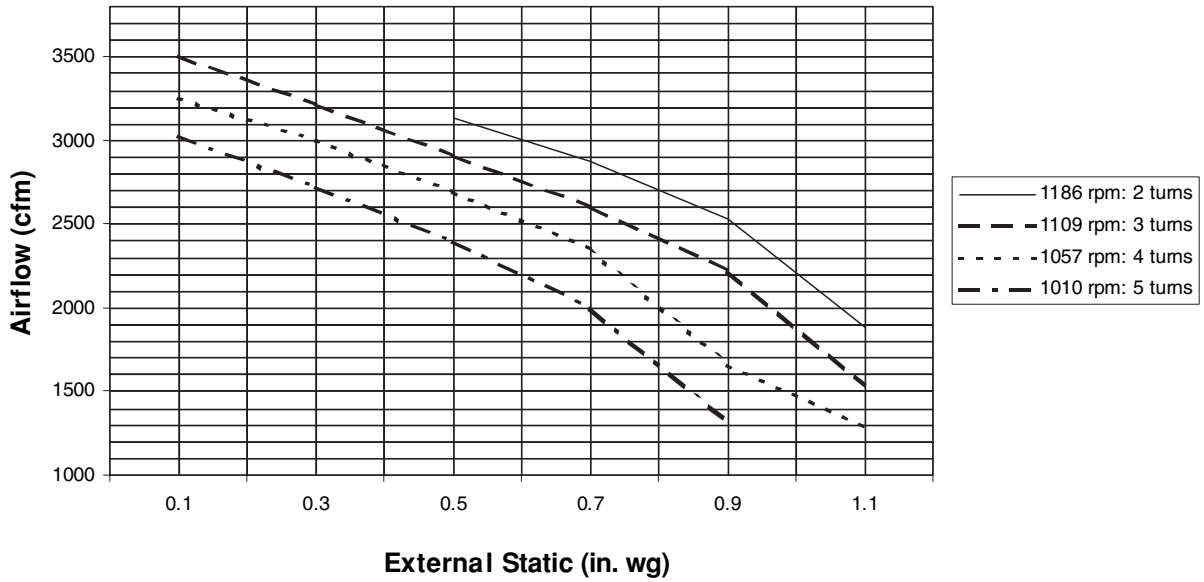
NOTE: Fan data includes pressure drop for 30% efficient 2-in. filters.

**Fig. 65 — 62M225 Supply Air Fan Performance Curves**



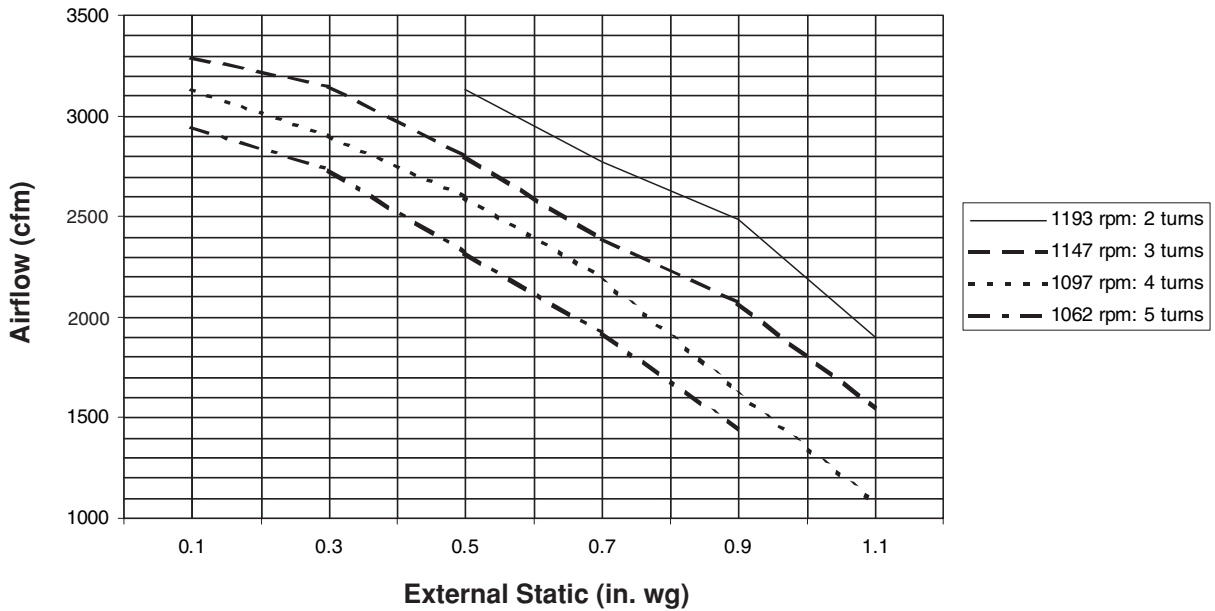
NOTE: Fan data includes pressure drop for 30% efficient 2-in. filters.

**Fig. 66 — 62M225 Exhaust Air Fan Performance Curves**



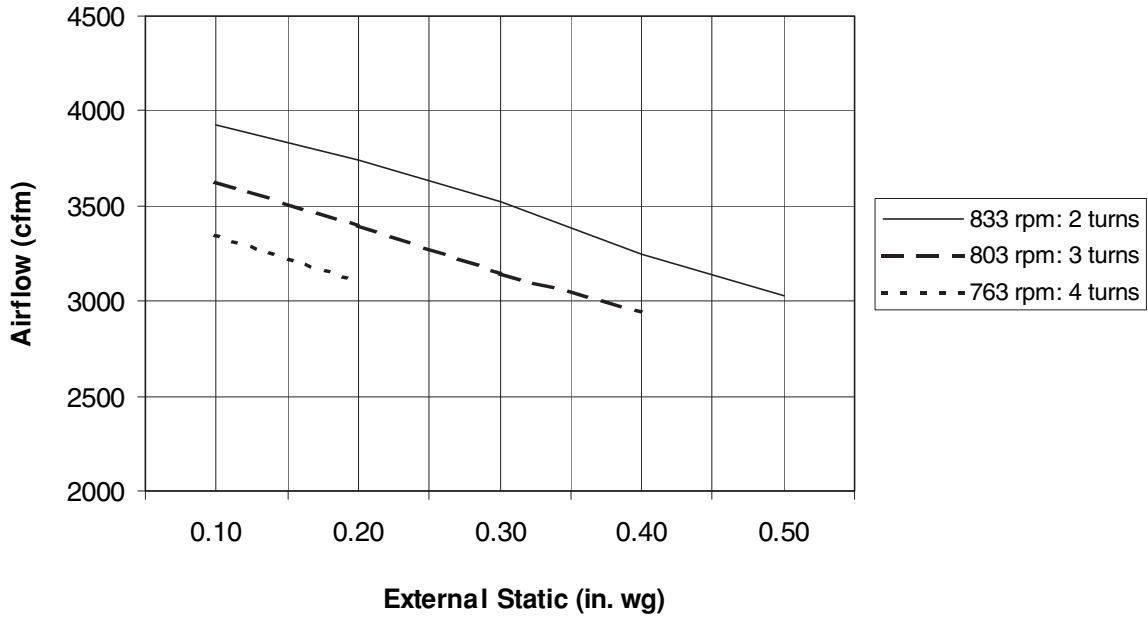
NOTE: Fan data includes pressure drop for 30% efficient 2-in. filters.

**Fig. 67 — 62M285 Supply Air Fan Performance Curves**



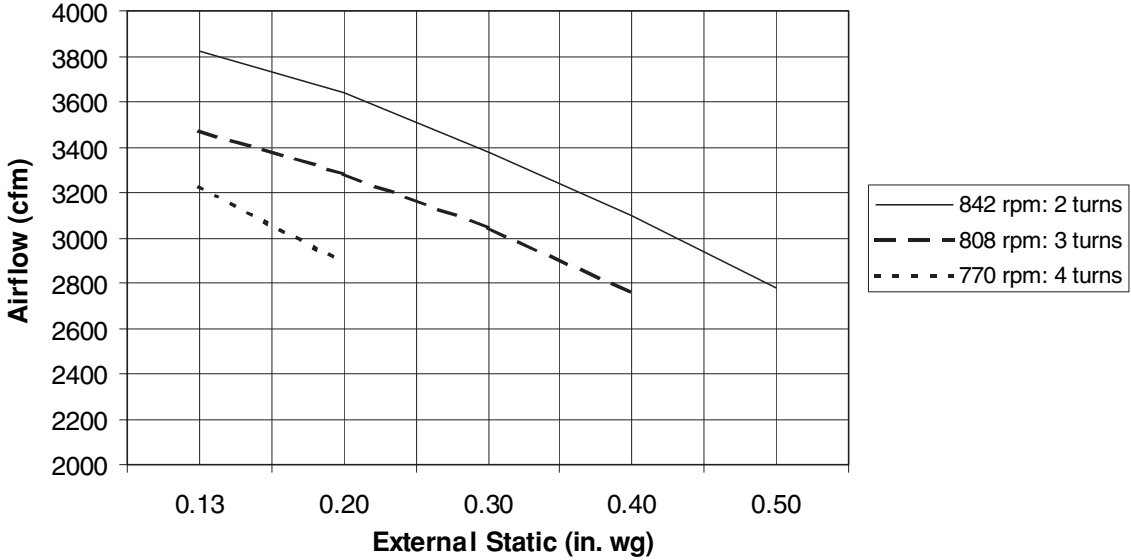
NOTE: Fan data includes pressure drop for 30% efficient 2-in. filters.

**Fig. 68 — 62M285 Exhaust Air Fan Performance Curves**



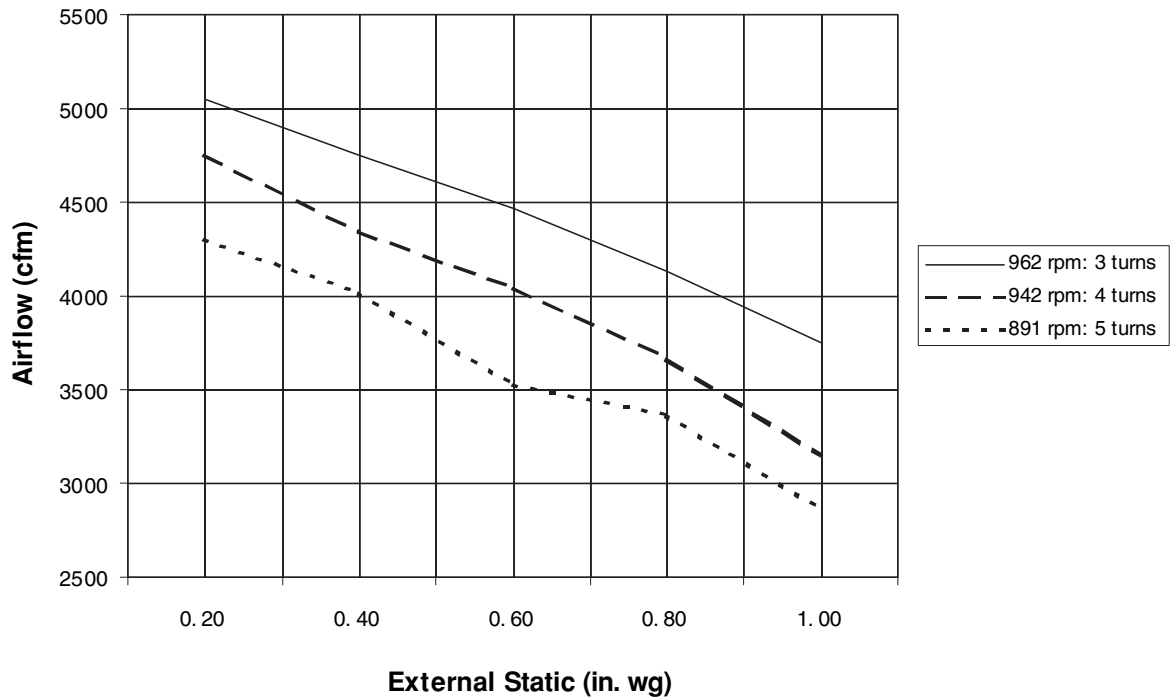
NOTE: Fan data includes pressure drop for 30% efficient 2-in. filters.

**Fig. 69 — 62M330 Supply Air Fan Performance Curves**



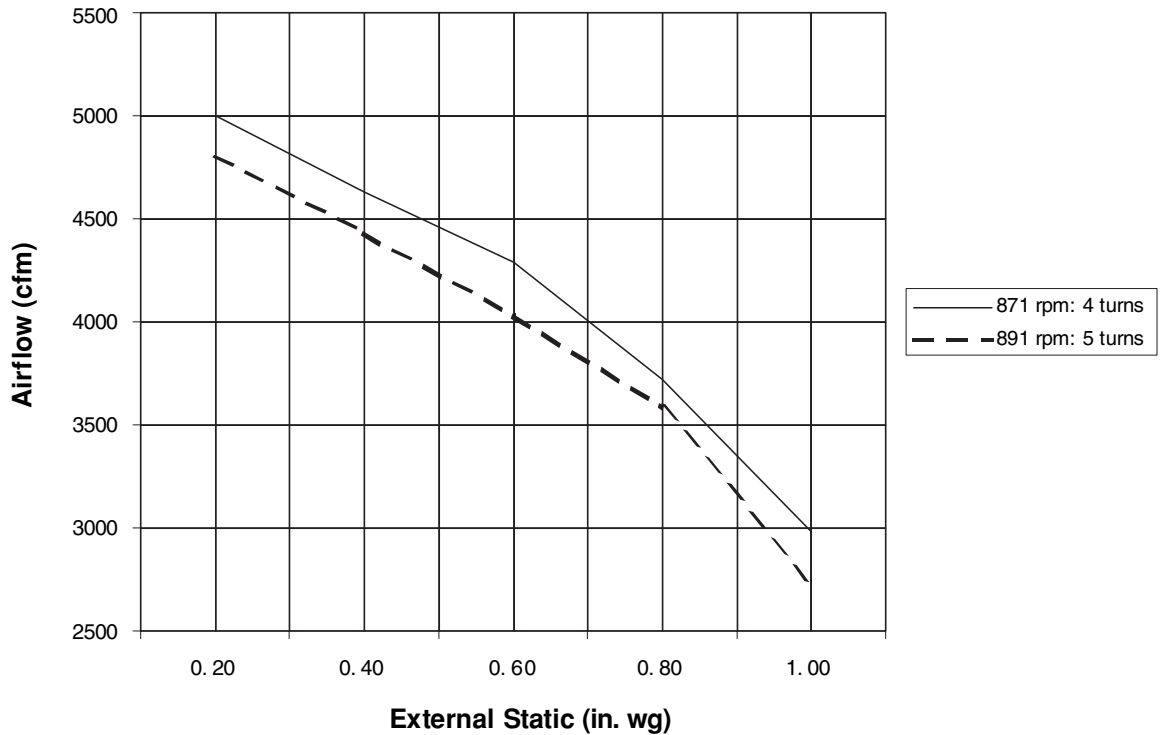
NOTE: Fan data includes pressure drop for 30% efficient 2-in. filters.

**Fig. 70 — 62M330 Exhaust Air Fan Performance Curves**



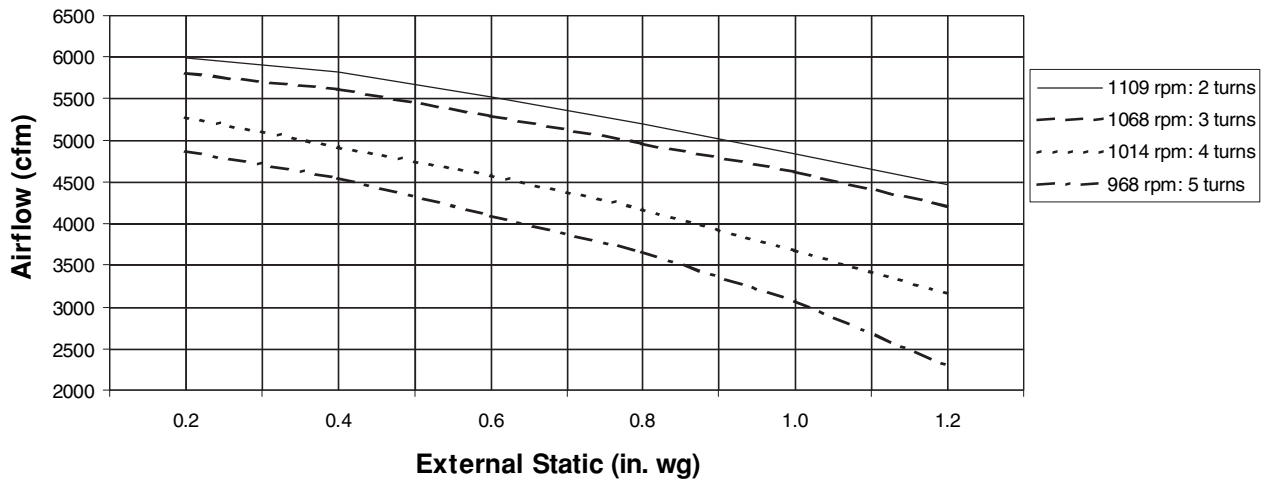
NOTE: Fan data includes pressure drop for 30% efficient 2-in. filters.

**Fig. 71 — 62M430 Supply Air Fan Performance Curves**



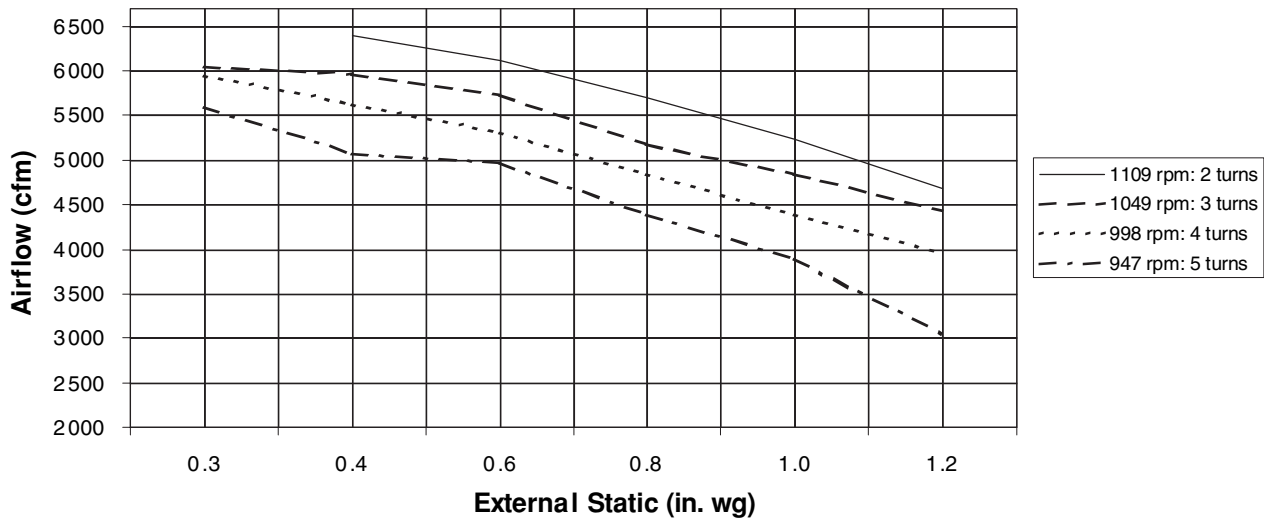
NOTE: Fan data includes pressure drop for 30% efficient 2-in. filters.

**Fig. 72 — 62M430 Exhaust Air Fan Performance Curves**



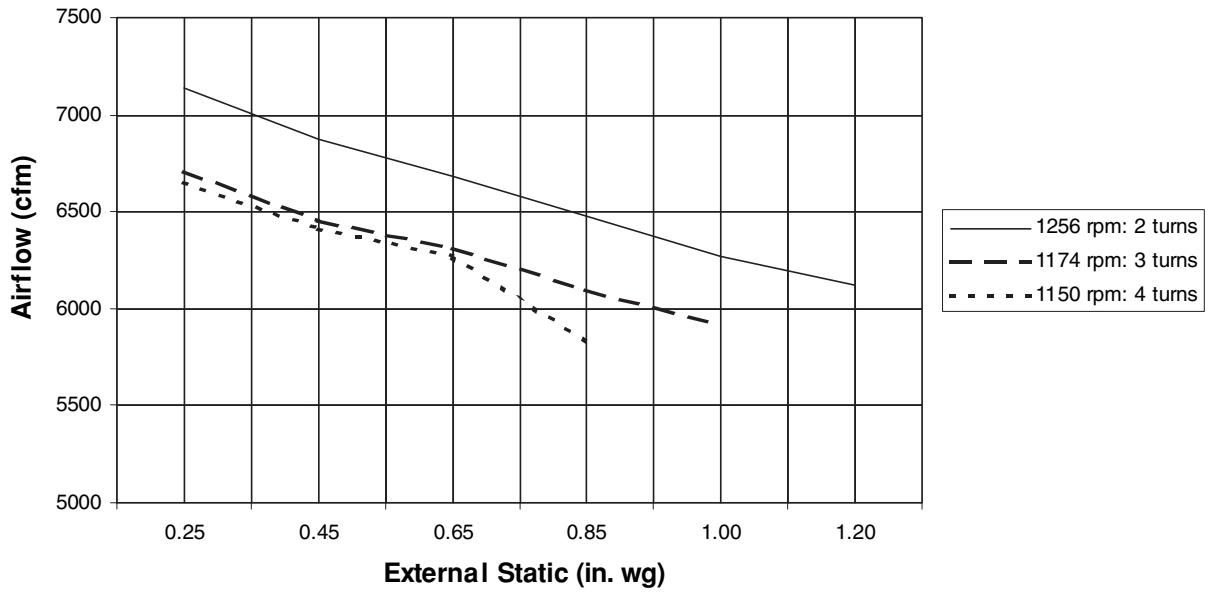
NOTE: Fan data includes pressure drop for 30% efficient 2-in. filters.

**Fig. 73 — 62M550 Supply Air Fan Performance Curves**



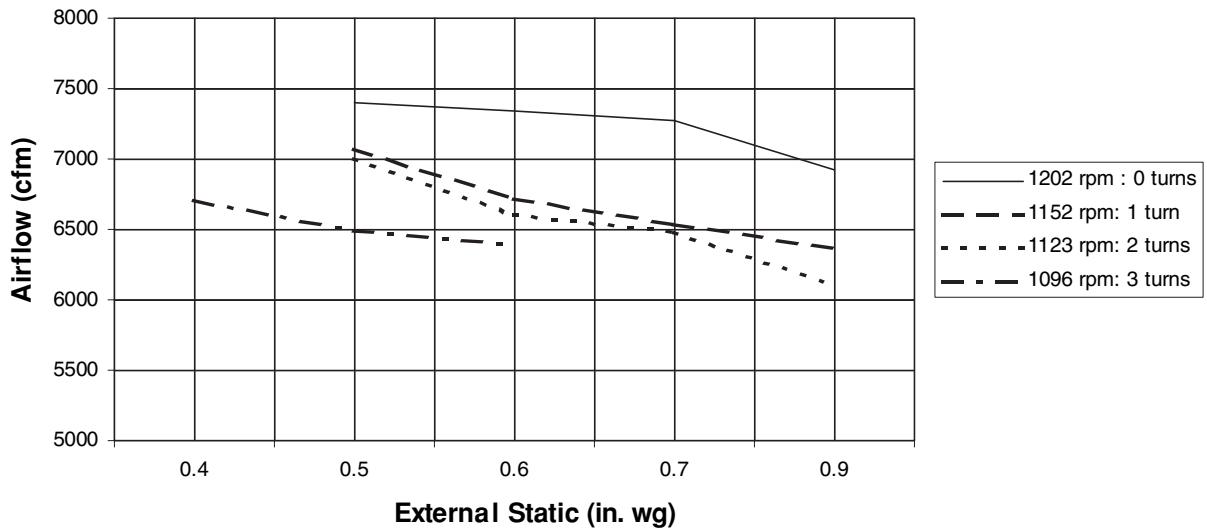
NOTE: Fan data includes pressure drop for 30% efficient 2-in. filters.

**Fig. 74 — 62M550 Exhaust Air Fan Performance Curves**



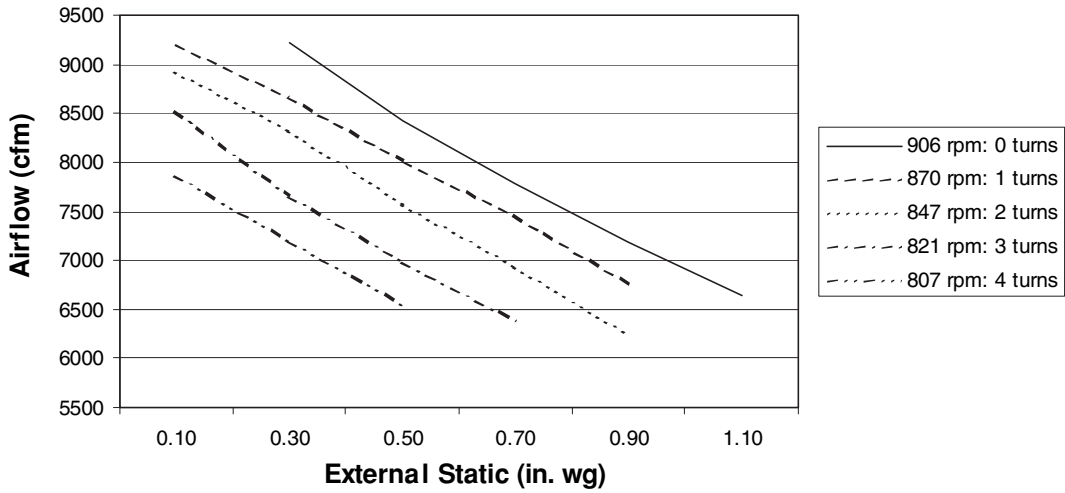
NOTE: Fan data includes pressure drop for 30% efficient 2-in. filters.

**Fig. 75 — 62M640 Supply Air Fan Performance Curves**



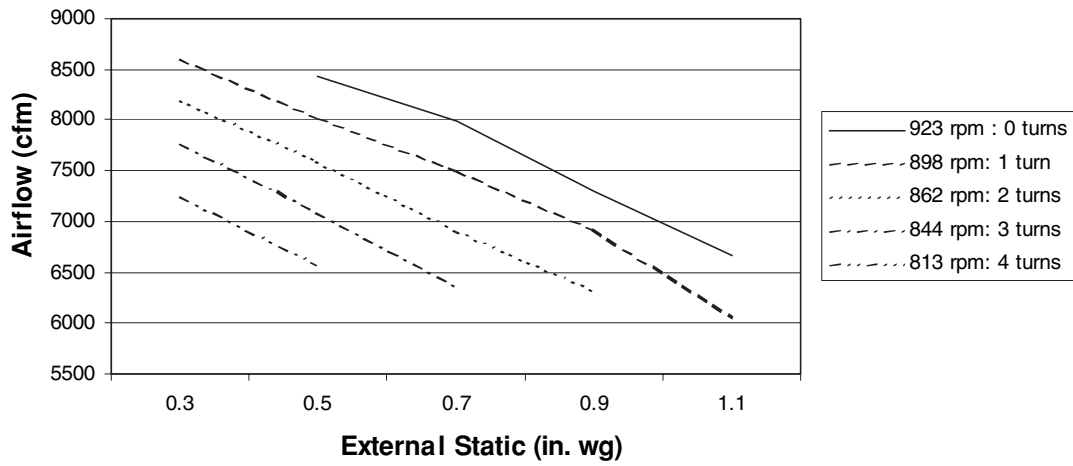
NOTE: Fan data includes pressure drop for 30% efficient 2-in. filters.

**Fig. 76 — 62M640 Exhaust Air Fan Performance Curves**



NOTE: Fan data includes pressure drop for 30% efficient 2-in. filters.

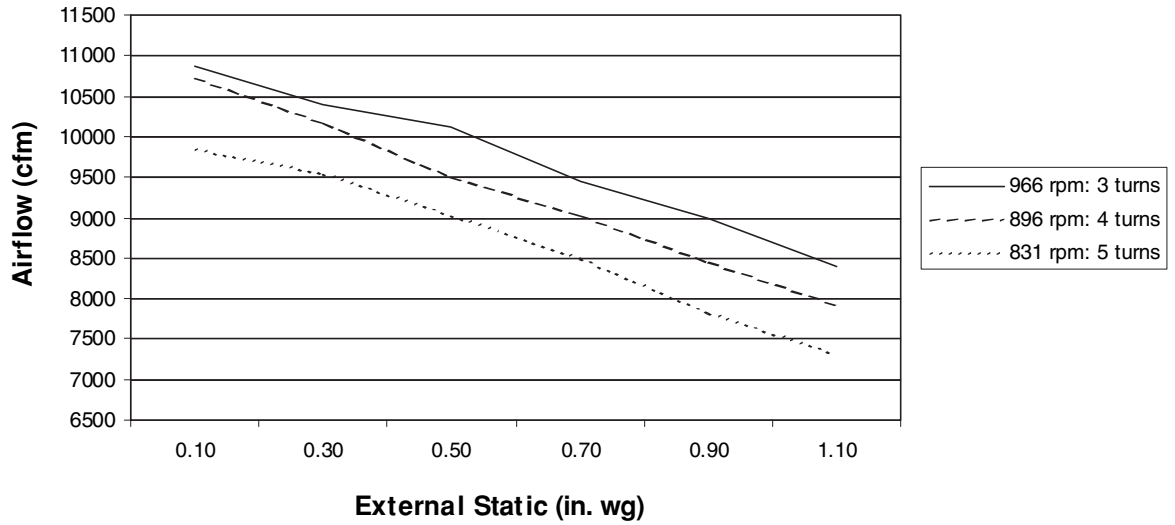
**Fig. 77 — 62M750 Supply Air Fan Performance Curves**



NOTE: Fan data includes pressure drop for 30% efficient 2-in. filters.

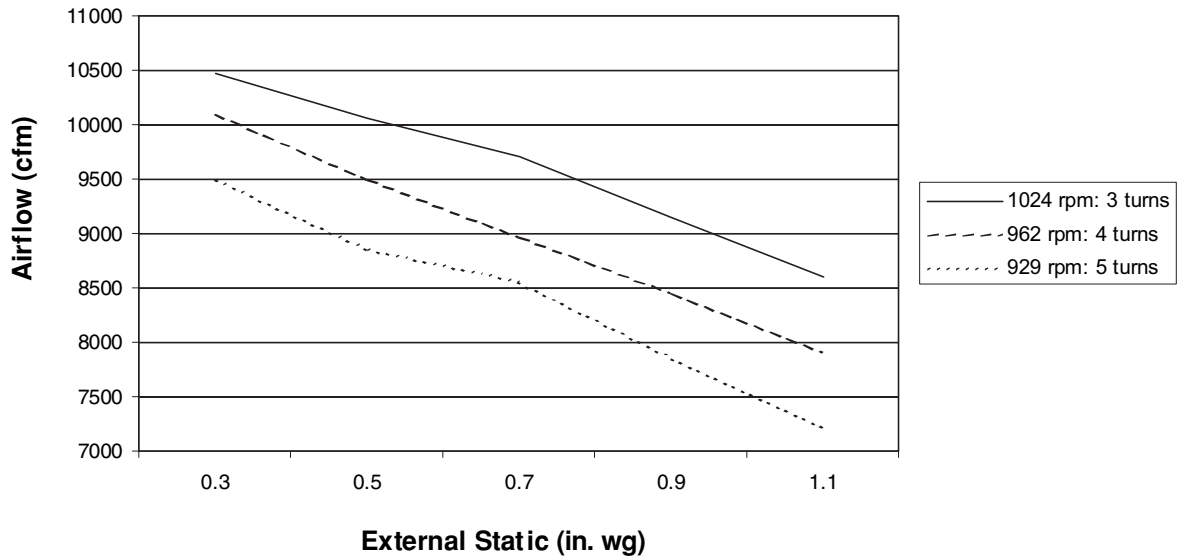
**Fig. 78 — 62M750 Exhaust Air Fan Performance Curves**





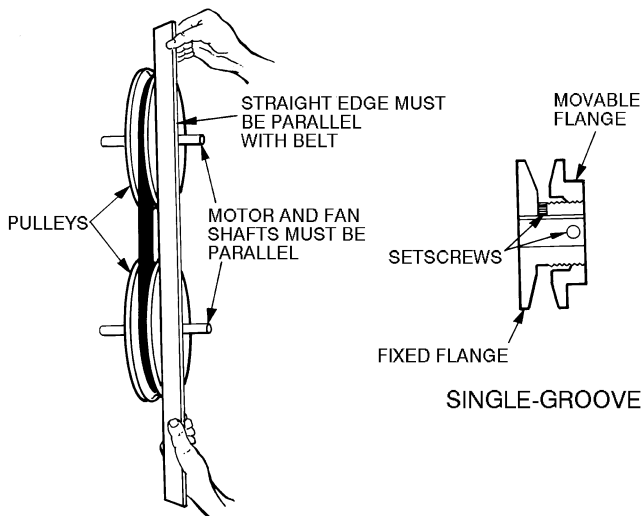
NOTE: Fan data includes pressure drop for 30% efficient 2-in. filters.

**Fig. 79 — 62M950 Supply Air Fan Performance Curves**

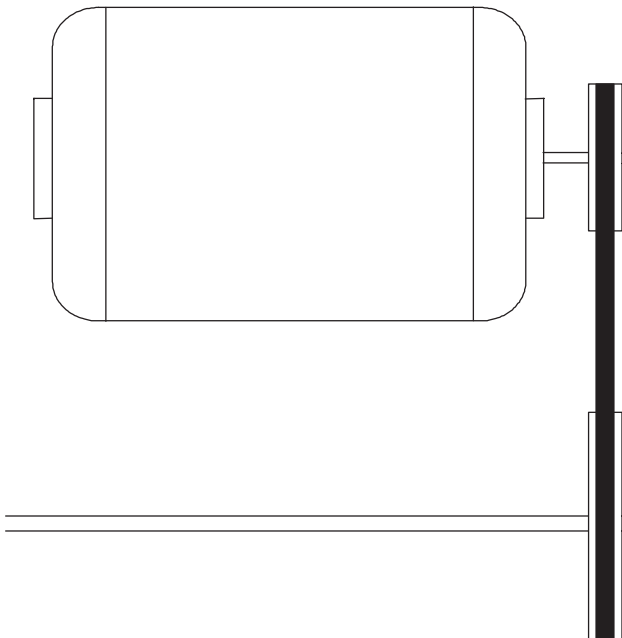


NOTE: Fan data includes pressure drop for 30% efficient 2-in. filters.

**Fig. 80 — 62M950 Exhaust Air Fan Performance Curves**



**Fig. 81 — Blower Motor Pulley Adjustment**



**Fig. 82 — Belt Alignment**

**Variable Air Volume Option** — This option can be used in conjunction with the CO<sub>2</sub> sensor option (ordered separately). Outside air and exhaust air blower speeds are independently controlled by variable frequency drives and modulated based upon space occupancy, which can be measured by CO<sub>2</sub>. The more people in the space the greater the CO<sub>2</sub> levels, the more outside air is introduced. This option eliminates over ventilating the space in less than full conditions. The ERV unit has completely different electrical characteristics when used with a variable air volume option. Refer to Tables 2 and 3.

### Operating Sequence

**OCCUPIED MODE** — While in occupied mode, the 62M ERV will operate per the ERV Timer option (scheduling program), the CO<sub>2</sub> sensor input, a combination of the scheduling option and CO<sub>2</sub> input, or the economizer accessory. Additionally, the low temperature lockout (LTLO) function locks out the 62M ERV if the outdoor-air temperature entering the wheel is below the set point. The LTLO is factory set at -10 F, and can be field adjusted from -30 F to 100 F.

**Occupied Mode, with CO<sub>2</sub> Sensor** — When the CO<sub>2</sub> sensor is used, it will measure the space CO<sub>2</sub> levels in parts per million (ppm). The 62M ERV CO<sub>2</sub> setting is factory set at 1,000 ppm but can be adjusted from 0 ppm to 2,000 ppm. When either the scheduling program and/or the CO<sub>2</sub> sensor calls for ERV operation, the ERV will activate the following:

- ERV wheel
- Outdoor air blower motor
- EXH blower motor
- Two-position damper opens

**NOTE:** The two-position damper option may slightly delay activation of the ERV blower motor.

**Occupied Mode, with Frost Protection** — In the occupied mode, the frost protection option will eliminate frost build-up on the ERV wheel using exhaust air. It is activated via a pressure differential across the ERV wheel. This set point is field set from 0.2 in. wg to 2.0 in. wg and must be set to 150% of the normal static pressure across the wheel. The frost protection feature is automatically locked out above 35 F.

**NOTE:** If the outdoor-air temperature is below 35 F, a dirty wheel may incorrectly activate the frost control feature if the differential pressure across the wheel exceeds the set point.

When the frost protection option is activated the following will occur:

- ERV wheel turns on.
- Outdoor air blower motor turns off.
- EXH blower motor is on.

**Occupied Mode, with the Pre-Heat Option** — In the occupied mode, the pre-heat option provides frost protection for the ERV wheel and slightly warms the outdoor air. This feature is factory set to activate at -5 F, and can be field adjusted from -30 F to 100 F. It is recommended that this set point be set at the frost threshold for the region in which it is used.

If desired, this feature may also be activated via a field supplied pressure differential switch to determine if frost build up has occurred on the ERV wheel.

**Occupied Mode, with the Economizer Accessory** — When using the economizer option, this allows for up to 100% outside air to be brought in for free cooling. During free cooling, the rooftop unit mechanical cooling may or may not be operating depending on the set points used with the rooftop unit. When using the economizer accessory, it is recommended that the minimum position be set to the closed position and the ERV should be set such that it is locked out when the economizer opens far enough to bring in the same level of outdoor air as the ERV.

If desired, this feature may also be activated via a field-supplied pressure differential switch to determine if frost build-up has occurred on the ERV wheel.

During free cooling, the following occurs:

- ERV wheel is turned off.
- Outdoor air blower is turned off.
- EXH blower motor turns on.
- Two-position outdoor-air damper is closed (if used).
- Two-position EXH damper is opened (if used).
- Stop/jog option will periodically rotate the ERV wheel to clean it during wheel bypass operation. This feature is factory set to activate every 10 minutes, for 20 seconds of operation. Both settings can be adjusted from 0 to 10 minutes.

**Wheel Bypass Option** — When using the wheel bypass option (with the stop/jog option), this allows free cooling through the wheel limited by the ERV airflow cfm limits. With this option the unit can be in free cooling or not depending on the temperature of the outdoor-air compared to the set point. When not in free cooling, the ERV will not operate. When in free cooling:

- ERV wheel is turned off.
- Outdoor-air blower is turned on.

- EXH blower motor is turned on.
- The two-position damper is open (if used).
- The stop/jog option will periodically rotate the ERV wheel to clean it during wheel bypass operation. This feature is factory set to activate every 10 minutes, for 20 seconds of operation. Both settings can be adjusted from 0 to 10 minutes.

**UNOCCUPIED MODE** — While in unoccupied mode, when below the low temperature lockout set point, the ERV wheel is off, and only the two-position damper option is opened to allow free cooling when desired. The dampers are controlled by either the ERV Timer option (scheduling program) or the CO<sub>2</sub> sensor input. Additionally, the frost protection and preheat options are also off. The low temperature lockout (LTLO) function locks out the 62M ERV if the outdoor-air temperature entering the wheel is below the set point. The LTLO is factory set at -10 F, and can be field adjusted from -30 F to 100 F.

When above the low temperature lockout set point and cooling is desired the economizer or wheel bypass option is also used. Depending on the option used with the 62M ERV, several sequences of operation could occur.

**Unoccupied Mode, with the Economizer Accessory** — When using the economizer option, this allows for up to 100% outside air to be brought in for free cooling. During free cooling, no mechanical cooling is operating and the following occurs:

- ERV wheel is turned off.
- Outdoor air blower motor is off.
- EXH blower motor is off.
- Two-position OA damper option is closed (if used).
- Two-position EXH damper is open (if used).
- The stop/jog option will periodically rotate the ERV wheel to clean it during wheel bypass operation.

When using the economizer option and mechanical cooling is operating, the economizer should be closed or at the minimum position.

**Unoccupied Mode, with the Wheel Bypass Option** — When using the wheel bypass option (with the stop/jog option), this allows free cooling through the wheel limited by the ERV cfm limits. With this option the unit can be in free cooling or not depending on the temperature of the OA compared to the set point. When in free cooling:

- ERV wheel is turned off.
- Outdoor air blower is on.
- EXH blower motor is on.
- Two-position damper is open (if used).

When not in free cooling:

- ERV wheel is turned off.
- Outdoor air blower motor is turned off.
- EXH blower motor is turned off.
- Two-position damper is closed (if used).

## SERVICE

### ⚠ CAUTION

Disconnect electrical power before servicing energy recovery cassette.

### Removing Wheel Segments for Cleaning (62M170-950 Units)

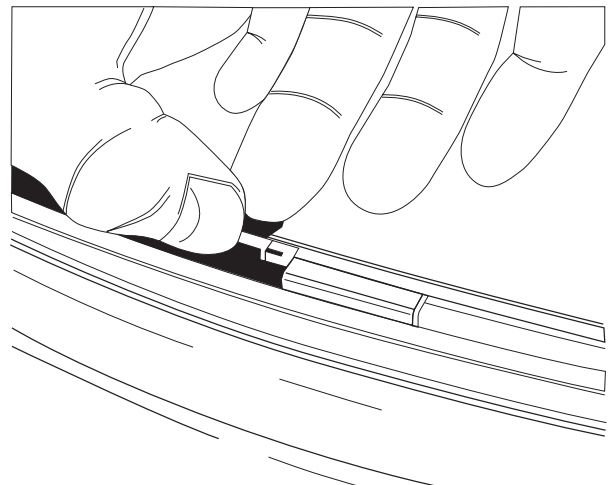
1. Unlock and open the segment retaining brackets on both sides of the selected segment opening. Refer to Fig. 83.
2. Gently lift segment outward.
3. Close segment retaining latches and rotate wheel 180 degrees to remove next segment. Follow this pattern to remove all segments. This pattern will help keep wheel balanced.

To install the segments see the Installing Wheel Segments (62M075-950) section.

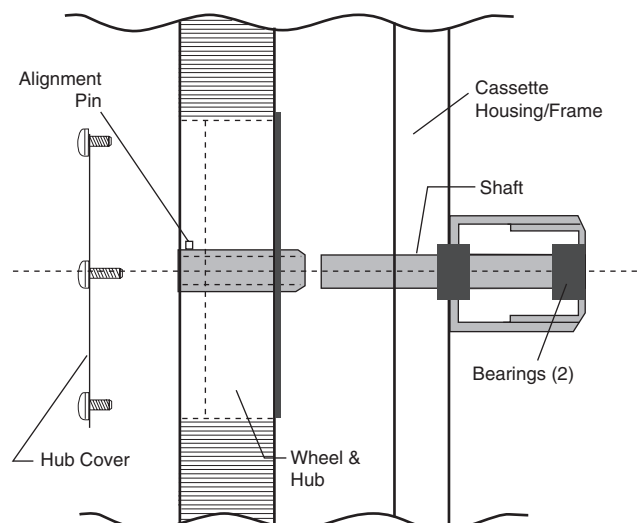
### Removing and Installing Non-Segmented Wheel for Cleaning (62M040 Units) — Non-segmented energy transfer wheels are secured to the shaft and bearing support beam by a Phillips head screw and hub cover. See Fig. 84.

To remove the energy transfer wheel, follow Steps 1-4 below. (See Fig. 84.) Reverse procedure for wheel installation.

1. Remove front seal assembly (pulley side of cassette) if present.
2. Remove belt from pulley and position temporarily around wheel rim.
3. Remove the hub cover from the wheel. Note the wheel to shaft alignment pin under the hub cover. Ensure this pin engages the notch at the end of the shaft when reinstalling the wheel.
4. Pull the wheel straight off the shaft. Handle wheel with care to prevent distorting of the wheel.



**Fig. 83 — Unlocking the Segment Retaining Brackets**



**Fig. 84 — 62M040 Energy Transfer Wheel Assembly**

## Removing and Installing Non-Segmented Wheel for Cleaning (62M075, 120 Units) —

Non-segmented energy transfer wheels include the shaft and are secured to two wheel support beams by two flange bearings with locking collars. See Fig. 85.

To remove the energy transfer wheel follow Steps 1-4 below. Reverse procedure for wheel installation.

1. Pull the wheel with shaft straight out of the motor side wheel support beam and bearing. Handle wheel with care to prevent distorting of the wheel.
2. Remove the pulley side wheel support beam with bearing by removing the 4 support beam screws.
3. Remove the belt from the pulley and position temporarily around the wheel rim.
4. Loosen the two set screws on each of the two wheel bearings. See Fig. 85.

### ⚠ CAUTION

When replacing wheel, retighten the 4 bearing set screws. Premature bearing failure could result.

## Installing Wheel Segments (62M170-950 Units)

### ⚠ WARNING

Before performing service or maintenance operations on unit, turn off main power switch to unit. Electrical shock could cause personal injury.

NOTE: Both installation and removal procedures must be performed from the pulley side of the cassette.

### ⚠ CAUTION

Weight of the installed segment will cause the wheel to accelerate in rotation. Failure to maintain control of the wheel rotation while installing all segments could cause severe injury to fingers or hand caught between revolving spokes and the bearing support beam. Handle of hammer, or other stop, should be inserted through spokes and above or below bearing support beams to limit rotation of unbalanced wheel. See Fig. 86.

NOTE: The 62M040-120 units contain non-segmented wheels which must be completely removed to be cleaned.

1. Begin by positioning one segment opening at the top of the cassette. Unlock and open the segment retaining brackets on both sides of the selected segment opening.
2. Holding the segment as vertical as possible and centered between spokes, insert nose of segment downward between the hub plates. See Fig. 87.

NOTE: The face of the segment, with the imbedded stiffener (vertical support between nose and rim end of segment) must face the motor side of the cassette. See Fig. 88.

3. Ease the segment downward until its outer rim clears the inside of the wheel rim. Then press the segment inward against the spoke flanges.
4. Close and latch segment retaining brackets to the position shown in Fig. 89. Make certain the retaining bracket is fully engaged under the catch.
5. Slowly rotate, by hand, the first installed segment to the bottom of the cassette, then install the second segment opposite the first. Repeat this sequence with the two installed segments rotated to the horizontal position to balance the weight of installed segments. Continue this sequence with the remaining segments.

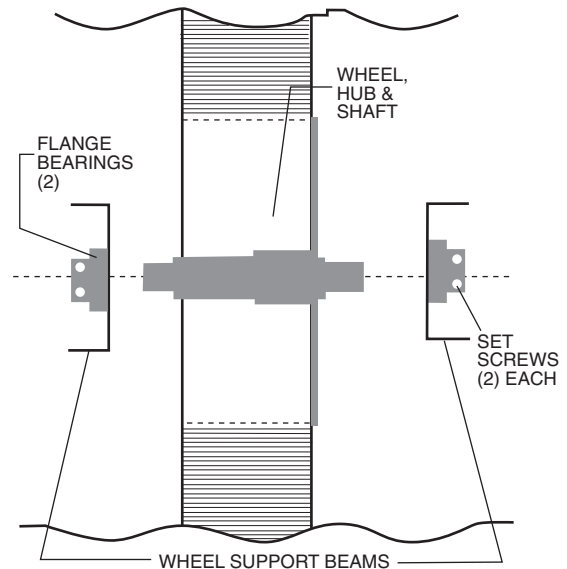


Fig. 85 — 62M075, 120 Energy Transfer Wheel Assembly

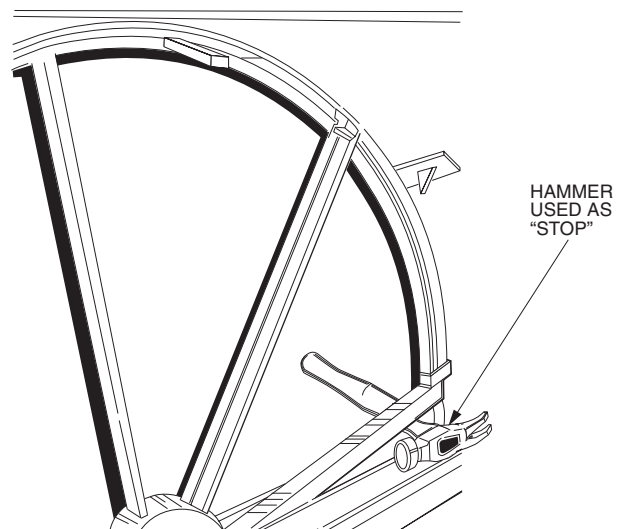


Fig. 86 — Using a Stop on the Wheel

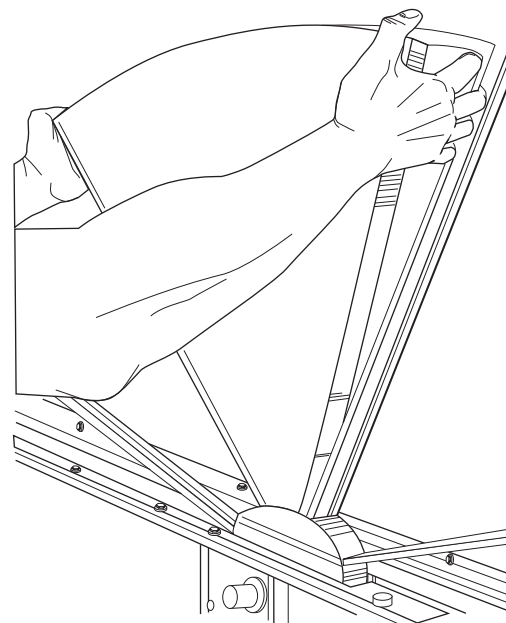
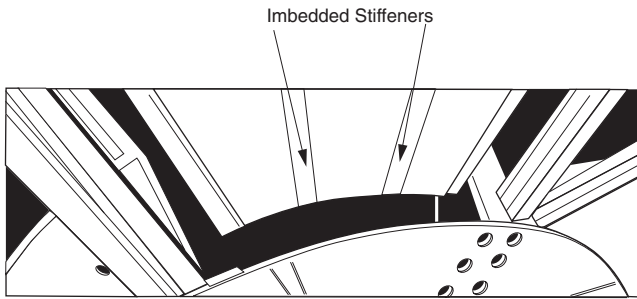
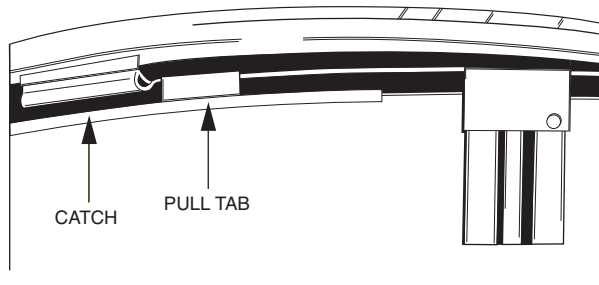


Fig. 87 — Inserting a Segment of the Wheel



**Fig. 88 — Motor Side View of Segment**



**Fig. 89— Latch Segment Retaining Brackets**

### Wheel Drive Motor and Pulley Replacement (62M170-095 Units)

1. Disconnect power to wheel drive motor.
2. Remove belt from pulley and position temporarily around wheel rim.
3. Loosen setscrew in wheel drive pulley using Allen wrench and remove pulley from motor drive shaft.
4. While supporting weight of drive motor in one hand, loosen and remove 4 mounting bolts.
5. Install replacement motor with hardware kit supplied.
6. Install pulley to dimension shown in Fig. 90 and secure setscrew to drive shaft.
7. Stretch belt over pulley and engage in groove.

### Belt Replacement

1. Obtain access to the pulley side bearing access plate. Remove two bearing access plate retaining screws and the access plate.

62M UNIT SIZE	ERV WHEEL	WHEEL SERIES	DIMENSION A (in.)
170	ERC-3623	36	1/4
225	ERC-3623	36	
285	ERC-3628	36	
330	ERC-5245	52	
430	ERC-5245	52	
550	ERC-5262	52	
640	ERC-5262	52	7/16
750	ERC-6488	64	
950	ERC-6488	64	

NOTE: The ERV wheel model number contains the wheel series number, and is located on a label near the drive pulley. For example, ERC-5245D is a 52 series wheel.

2. Using hexagonal wrench, loosen setscrew in bearing locking collar. Using light hammer and drift (in drift pin hole) tap collar in the direction of wheel rotation to unlock collar. Remove collar.
3. Using socket wrench with extension, remove two nuts which secure bearing housing to the bearing support beam. Slide bearing from shaft.

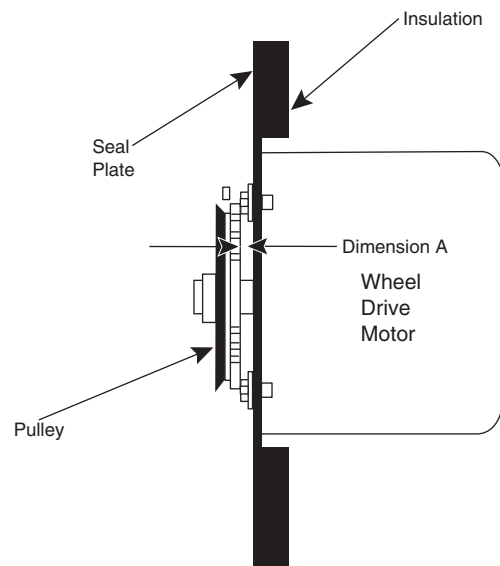
NOTE: Slight hand pressure against wheel rim will lift weight of wheel from inner race of bearing to assist bearing removal and installation. If not removable by hand, use bearing puller.

### ⚠ CAUTION

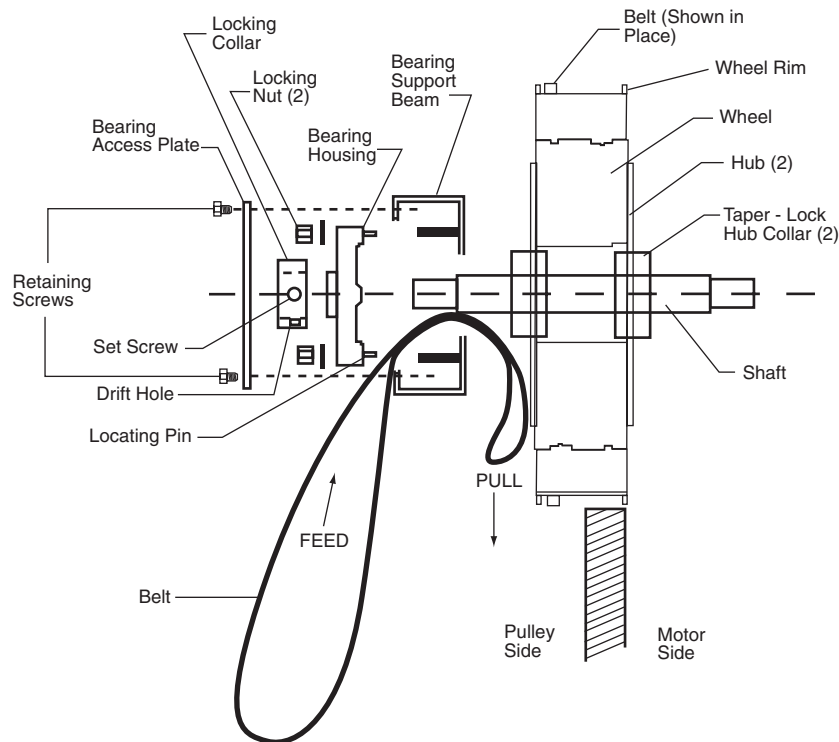
Protect hands and belt from possible sharp edges of hole in bearing support beam.

4. Using a wrench, remove diameter seal retaining screws or hub seal retaining screws. Remove diameter seals or hub seal from bearing beam. See Fig. 91.
5. Form a small loop of belt and pass it through the hole in the bearing support beam. Grasp the belt at the wheel hub and pull the entire belt down. Loop the trailing end of the belt over the shaft (Fig. 91 shows belt partially through the opening).
6. Reinstall the bearing onto the wheel shaft, being careful to engage the two locating pins into the holes in the bearing support beam. Secure the bearing with two self-locking nuts.
7. Install the belts around the wheel and pulley according to the instructions provided with the belt.
8. Reinstall diameter seals or hub seal and tighten retaining screws. Rotate wheel in clockwise direction to determine that wheel rotates freely with slight drag on seals.
9. Reinstall bearing locking collar. Rotate collar by hand in the direction the wheel rotates (see label provided on each cassette for wheel rotation). Lock in position by tapping drift pin hole with hammer and drift. Secure in position by tightening setscrew.
10. Reinstall bearing access cover.
11. Apply power to wheel and ensure that the wheel rotates freely without interference.

ALTERNATE BELT REPLACEMENT METHODS — Alternate belt replacement methods may be used in some applications depending upon accessibility of the cassette. Consult instructions provided with the belt for further information.



**Fig. 90 — Pulley Location**



**Fig. 91 — Belt Replacement (Diameter Seals Removed)**

## MAINTENANCE

Routine maintenance of the energy recovery cassettes includes periodic cleaning of the energy recovery wheel as well as inspection of the air seals and wheel drive components as follows:

**Cleaning** — The need for periodic cleaning of the energy recovery wheel will be a function of operating schedule, climate and contaminants in the indoor air being exhausted, and the outdoor air being supplied to the building.

The air exchange wheel is “self-cleaning” with respect to dry particles due to its laminar flow characteristics. Smaller particles pass through; larger particles land on the surface and are blown clear as the flow direction is reversed. Any material that builds up on the face of the wheel can be removed with a brush or vacuum. The primary need for cleaning is to remove oil-based aerosols that have condensed on energy transfer surfaces.

A characteristic of all dry desiccants, such films can close off micron sized pores at the surface of the desiccant material, reducing the efficiency by which the desiccant can adsorb and desorb moisture and also build up so as to reduce airflow.

In a reasonably clean indoor environment such as a school or office building, measurable reductions of airflow or loss of sensible effectiveness may not occur for several years. Measurable changes in latent energy transfer can occur in shorter periods of time in applications such as moderate occupant smoking or cooking facilities. In applications experiencing unusually high levels of occupant smoking or oil-based aerosols such as industrial applications involving the ventilation of machine shop areas for example, annual washing of energy transfer may be necessary to maintain latent transfer efficiency. Proper cleaning of the energy recovery wheel will restore latent effectiveness to near original performance.

To clean, gain access to the energy recovery wheel and remove wheel. Brush foreign material from the face of the wheel. Wash the wheel in a 5% solution of non-acid based coil cleaner or alkaline detergent and warm water.

Soak in the solution until grease and tar deposits are loosened.

NOTE: Some staining of the desiccant may remain and is not harmful to performance.

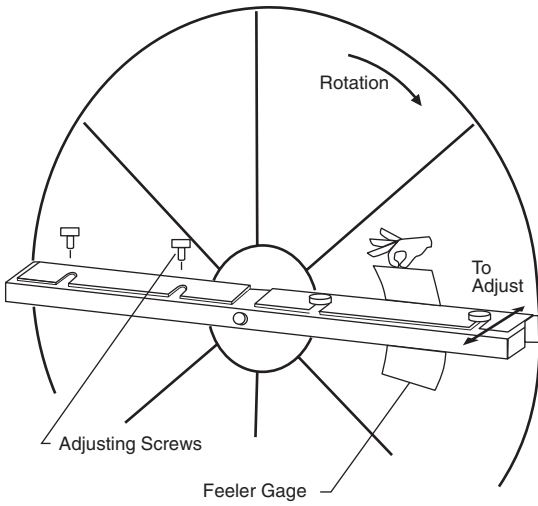
Before removing, rapidly run finger across surface of wheel to separate polymer strips for better cleaning action. Rinse dirty solution from wheel and remove excess water before reinstalling.

### **⚠ CAUTION**

Do not use acid based cleaners, aromatic solvents, steam or temperatures in excess of 170 F; damage to the wheel may result.

**Air Seals** — Diameter seals are provided on each cassette to minimize transfer of air between the counter flowing airstreams.

To adjust diameter seals, loosen diameter seal adjusting screws and back seals away from wheel surface (Fig. 92). Rotate wheel clockwise until two opposing spokes are hidden behind the bearing support beam. Using a folded piece of paper as a feeler gage, position paper between the wheel surface and diameter seals. Adjust seals towards wheel surface until a slight friction on the feeler gage (paper) is detected when gage is moved along the length of the spoke. Retighten adjusting screws and recheck clearance with “feeler” gage.



**Fig. 92 — Diameter Seal Adjustment**

**Wheel Drive Components** — The wheel drive motor bearings are pre-lubricated and no further lubrication is necessary. Make certain air cooling ports are not blocked.

The wheel drive pulley is secured to the drive motor shaft by a setscrew. The setscrew is secured with removable adhesive to prevent loosening. Annually confirm setscrew is secure.

The wheel drive belt is a urethane stretch belt designed to provide constant tension through the life of the belt. No adjustment is required. Inspect the drive belt annually for proper tracking and tension. A properly tensioned belt will turn the wheel immediately after power is applied with no visible slippage during start-up.

---

**Manufacturer reserves the right to discontinue, or change at any time, specifications or designs without notice and without incurring obligations.**

Book | 1 | 4  
Tab | 10a | 12a

Catalog No. 536-220

Printed in U.S.A.

Form 62M-1SI

Pg 80

1-06

Replaces: New





# START-UP CHECKLIST

**A. Project Information:**

Start-Up Performed By \_\_\_\_\_

 Name \_\_\_\_\_  
 Job Name \_\_\_\_\_  
 ERV Unit Designation \_\_\_\_\_  
 Phone Number \_\_\_\_\_

Design Information			
Application			Coupled to rooftop unit or stand-alone.
CFM			
External Static Pressure			
Supply Discharge			Down or horizontal (use horizontal for mated application)
Return Discharge			Down or horizontal (use horizontal for mated application)
Voltage/Phase			
ERV Unit Part Number			
<b>Specify Rooftop Unit.</b>			<b>NOTE: Complete This Section for Coupled Applications Only</b>
Model Number			
HVAC Unit Discharge Type			Down discharge or horizontal discharge.
<b>Roof Curb (Option)</b>			
	<b>Yes</b>	<b>No</b>	
14-in. Tall Roof Curb			Field install
Vibration Isolation Curb			Field install
<b>Transition (Option)</b>			<b>NOTE: Complete This Section for Coupled Applications Only.</b>
Rooftop Unit Discharge			Down or horizontal discharge rooftop unit.
Percent Outside Air			Outside air thru ERV unit as a percent of total rooftop unit cfm.
Transition Part Number			Field install
<b>Inside Mounting Kit (Option)</b>			<b>NOTE: Complete This Section for Indoor Applications Only.</b>
	<b>Yes</b>	<b>No</b>	
			Factory installed
			Removes rainhoods and adds duct flanges.
<b>Electrical Disconnect (Option)</b>			
	<b>Yes</b>	<b>No</b>	
Fused			Factory installed
Switched			Factory installed
<b>Two-Position Motorized Dampers (Option)</b>			
	<b>Yes</b>	<b>No</b>	
Outside Air Damper			Factory installed
Exhaust Air Damper			Factory installed
<b>Economizer (Accessory for Rooftop Unit)</b>			<b>NOTE: Do Not Use With Wheel Bypass Option.</b>
	<b>Yes</b>	<b>No</b>	
			Field install
			Special economizers required for some rooftop units. See the price pages.
<b>Wheel Bypass With Stop Jog Control (Option)</b>			<b>NOTE: Do Not Use With Economizer Option.</b>
	<b>Yes</b>	<b>No</b>	
			Factory installed
			Stops the ERV wheel rotation for free-cooling.
<b>Stop Jog Control (Option)</b>			<b>NOTE: Use With Economizer Option.</b>
	<b>Yes</b>	<b>No</b>	
			Factory installed
			Jogs the wheel during economizer mode to expel contaminants.
<b>Pre-Heater (Option)</b>			
	<b>Yes</b>	<b>No</b>	
kW			Factory installed
Temp Control			
Temp and Static Pressure Control			
<b>Frost Protection (Option)</b>			<b>NOTE: Do Not Use With Pre-Heater.</b>
	<b>Yes</b>	<b>No</b>	
			Factory installed
			Defrosts wheel with exhaust air, by shutting down OA blower.
<b>Low Temperature Lock Out (Option)</b>			
	<b>Yes</b>	<b>No</b>	
			Factory installed
			Shut down ERV unit at low temperature set point.
<b>Filter Maintenance Indicator (Option)</b>			
	<b>Yes</b>	<b>No</b>	
			Factory installed
			Senses static pressure across OA filters (can be set for return filters).
<b>ERV Blower Maintenance Indicator (Option)</b>			
	<b>Yes</b>	<b>No</b>	
			Factory installed
			Monitors OA and EA blowers and sends signal on electrical spike.
<b>ERV Wheel Maintenance Indicator (Option)</b>			
	<b>Yes</b>	<b>No</b>	
			Factory installed
			Monitors ERV wheel and sends signal on electrical spike.
<b>Airflow Monitor (Option)</b>			
	<b>Yes</b>	<b>No</b>	
			Factory installed
			Gages display static pressure across wheel for OA and exhaust air.
<b>ERV Control Timer (Option)</b>			
	<b>Yes</b>	<b>No</b>	
24 Volt Mounted in ERV			Factory installed
115 Volt Remote Mount			Field install
			24 hour / 7 day timer field mounted in remote location.
<b>VAV Control (Option)</b>			
	<b>Yes</b>	<b>No</b>	
			Factory installed
			Provides independent VFD control for both OA and exhaust air.
<b>CO<sub>2</sub> Sensor (Option)</b>			
	<b>Yes</b>	<b>No</b>	
Wall Mount or Duct Mount			Field install
Duct Mount With External View			Field install
<b>For 62M040 Cabinet Only</b>			
	<b>Yes</b>	<b>No</b>	
Equipment Support			Field installed
Base Rail Option			Factory installed
Hinged Door Option			Factory installed
2-in. Filters Option			Factory installed
Door Interlock Safety Switches			Factory installed
Test Port Option			Factory installed
			Use for coupled applications. Must be ordered when 62M040 sits on a roof curb. Provides hinges and latches on both access doors. Replaces the standard 1-in. filters with 2-in. high efficiency, pleated. Cuts power to ERV unit when access doors are opened during operation. Allows for convenient monitoring of static / airflow across ERV wheel.

Manufacturer reserves the right to discontinue, or change at any time, specifications or designs without notice and without incurring obligations.

## Free Manuals Download Website

<http://myh66.com>

<http://usermanuals.us>

<http://www.somanuals.com>

<http://www.4manuals.cc>

<http://www.manual-lib.com>

<http://www.404manual.com>

<http://www.luxmanual.com>

<http://aubethermostatmanual.com>

Golf course search by state

<http://golfingnear.com>

Email search by domain

<http://emailbydomain.com>

Auto manuals search

<http://auto.somanuals.com>

TV manuals search

<http://tv.somanuals.com>