

Installation and Start-up Instructions

NOTE: Read the entire instruction manual before starting the installation.

SAFETY CONSIDERATIONS

Improper installation, adjustment, alteration, service, maintenance, or use can cause explosion, fire, electrical shock or other conditions which may cause personal injury or property damage. Consult a qualified installer, service agency, or your distributor or branch for information or assistance. The qualified installer or agency must use factory-authorized kits or accessories when modifying this product. Refer to the individual instructions packaged with the kits or accessories when installing.

Follow all safety codes. Wear safety glasses and work gloves. Use quenching cloth for brazing operations. Have fire extinguisher available. Read these instructions thoroughly and follow all warnings or cautions attached to the unit. Consult local building codes and National Electrical Code (NEC) for special requirements.

It is important to recognize safety information. This is the safety-alert symbol \triangle . When you see this symbol on the unit and in instructions or manuals, be alert to the potential for personal injury.

Understand the signal word DANGER, WARNING, or CAUTION. These words are used with the safety-alert symbol. DANGER identifies the most serious hazards which will result in severe personal injury or death. WARNING signifies hazards that could result in personal injury or death. CAUTION is used to identify unsafe practices which would result in minor personal injury or product and property damage.

\triangle WARNING

Before installing or servicing system, always turn off main power to system. There may be more than 1 disconnect switch. Turn off accessory heater power if applicable. Electrical shock can cause personal injury or death.

GENERAL

Intake and discharge are on front of the unit. A minimum service access distance of 30 in. behind unit must be provided.

NOTE: Refer to unit rating plate for ratings.

This condensing unit is designed for use with evaporator coils or fan coils equipped with capillary tube or piston-type refrigerant control device. It may also be used with evaporators which have expansion valves that equalize pressure during the off cycle or hard shut-off expansion valves. The 018 size with hard shut-off expansion valve requires a hard start kit.

BEFORE INSTALLATION

Check power supply: voltage, frequency and phase must correspond with data on unit rating plate. Power supply must be able to handle the additional load imposed by this equipment.

The 38GNA does not have a transformer. Therefore, the furnace transformer (or another source) must be used as a low-voltage supply. Transformer must have an additional capacity of 15 va above the requirement of furnace or air handler.

The 024 size is equipped with a time-delay device which prevents restart within 5 minutes of power interruption.

Compressor motor is equipped with an internal protector. Excessive current or temperature causes protector to open which gives indication of an open circuit in motor winding. Sufficient time should be allowed for overload to reset before assuming compressor has an open winding.

Compressor motor is designed to start under low-load conditions only. Make sure system pressures have equalized before attempting to start unit. Equalization takes approximately 3 minutes. Owner should be informed not to short-cycle unit with thermostat as this causes compressor to trip out on overload.

Each unit is shipped with refrigerant charge adequate for use with matching coils and refrigerant tubing kits. Charge is adequate for systems using 25 ft of interconnecting tubing. See unit rating plate for charge quantity. See Refrigerant Charging section and Table 2 for adjustment requirements.

\triangle WARNING

Relieve all pressure before refrigerant system repair or final unit disposal to avoid personal injury or death. Use all service ports and open all flow control devices, including solenoid valves.

\triangle CAUTION

Do not vent refrigerant to atmosphere. Recover during system repair or final unit disposal.

NOTE: Check indoor coil piston to see if it matches the required piston shown on unit rating plate. If it does not match, replace indoor coil piston with piston shipped with this unit. The piston shipped with outdoor unit is correct for any approved indoor coil combination.

Table 1—Installation Data (In.)

38GNA	018	024
Through-the-Wall Clearance Dim.	26-1/2 x 29	
Air Clearance	36	
Concrete Mounting Pad Dim.	27 x 17 x 5	
Service Clearance*	Sides	0
	Back	30

*Unit is serviced through rear access panel. Therefore, unit can be installed with 0-in. end clearance.

INSTALLATION

Install condensing unit either through-the-wall, outdoors on a slab or on the roof. When installing, allow sufficient space for airflow clearance, wiring, refrigerant piping and servicing. Consult local building codes and National Electrical Code (NEC) for special installation requirements. See Fig. 1, 2 and 3 and Table 1 for detailed installation data.

Manufacturer reserves the right to discontinue, or change at any time, specifications or designs without notice and without incurring obligations.

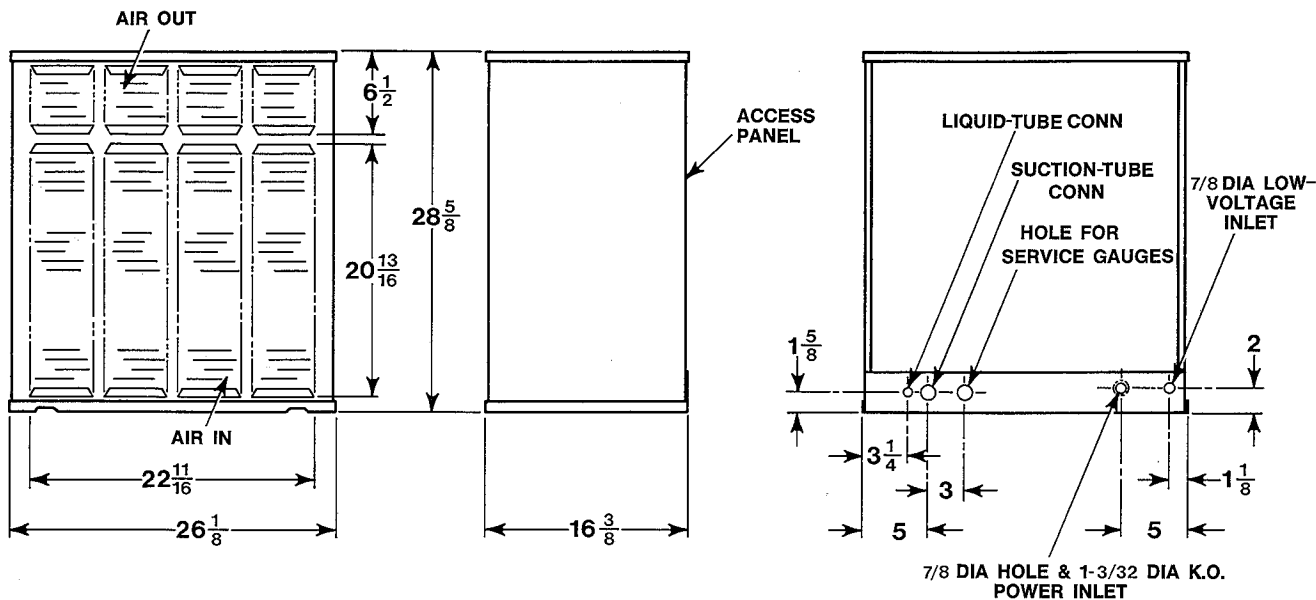
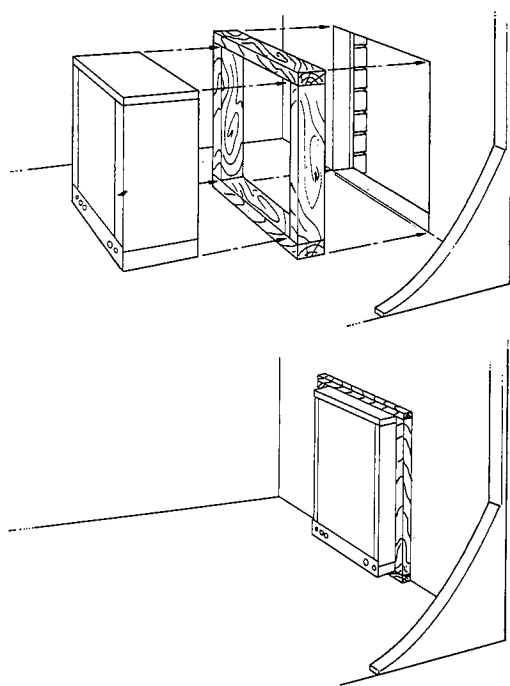

Fig. 1—Dimensions and Connections

A75135



A88545

Fig. 2—Roughing-In Supporting Frame

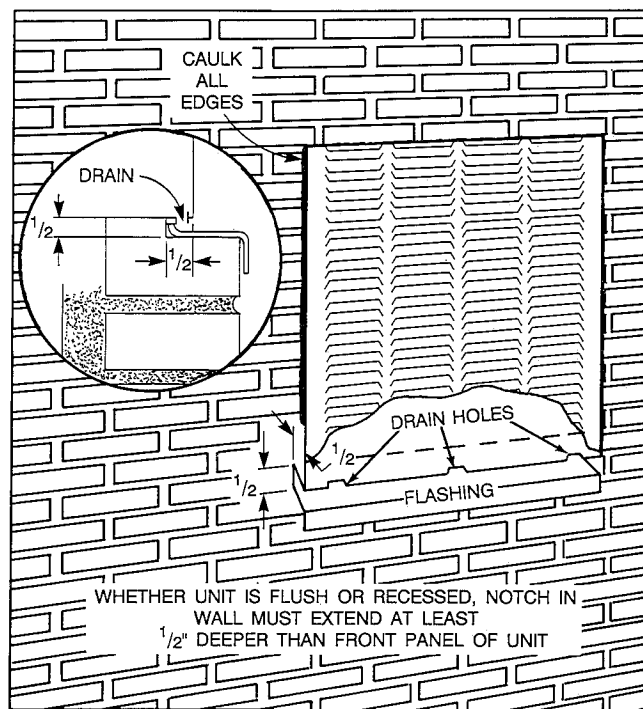

A65494

Fig. 3—Flush or Recess Mounting

Step 1—Make Opening in Wall

Make an opening approximately 26-1/2 x 29 in. in a wall as close to the cooling unit as possible. Build a frame to support the condensing unit. (See Fig. 2.)

1. Insert condensing unit with frame into the wall opening.
2. Extend unit approximately 1 in. beyond outside (finished) wall and tilt to the outside to allow rainwater to drain off. (See Fig. 3.)
3. Fasten unit to frame with metal straps.
4. Use flashing under unit and caulk all edges to provide weathertight seal. (See Fig. 3.)

Step 2—Make Piping Connections

SELECT CORRECT LIQUID AND SUCTION LINE LENGTHS/DIAMETERS — Refer to Table 2.

INSTALL REFRIGERANT LINES — The condensing unit is fully charged at the factory. Be sure both service valves are front seated (turned clockwise) to avoid loss of charge. *Do not remove refrigerant line connection seals from condensing unit, matching coil, or refrigerant tubing until ready to make actual connection at point of seal.*

Table 2—Tubing Data

UNIT SIZE	REFRIGERANT LINE LENGTH			
	10 to 50 ft		51 to 100 ft	
	Diameter (In.)			
	Suction	Liquid	Suction	Liquid
018, 024	5/8	3/8	3/4	3/8

1. Maximum vertical separation for evaporator over condensing unit is 50 ft.
2. Over 50 ft of vertical separation, the condensing unit must be located above the evaporator. For requirements beyond 50 ft, obtain information from distributor or consult Long-Line Application Guideline.
3. Charge adjustment is required when using more than 25 ft of tubing. See Refrigerant Charging information on unit rating plate.
4. Do not use larger than 3/4-in. suction line.

If accessory tubing package or evaporator coil has been open for more than 5 minutes, evacuate evaporator coil and tubing system. Always evacuate if field-supplied tubing is used. See Evacuation section.

Ensure field-supplied tubing is of refrigerant grade. Insulate the suction line with insulation that has an adequate vapor barrier. Evacuate tubing.

1. Run refrigerant lines as directly as possible, avoiding any unnecessary turns and bends.
2. Tape the liquid line to the top of the insulated suction line for support.
3. Suspend the refrigerant lines so they do not damage the insulation on the suction line and do not transmit vibration to the structure.
4. If the refrigerant lines are too long, the excess may be cut off.
5. Connect tubing to the condensing unit. The refrigerant tubing and evaporator coil should be leak tested upon completion.

When making piping connections, be sure to provide clearance at unit for electrical connection.

Connect suction and liquid refrigerant lines to condensing unit. (See Fig. 1.) Make suction line connection first.

Two grommets are provided to seal the gap between refrigerant lines and unit casing. Cut small grommet, slip it over liquid line and push it into casing opening. Gap around suction line is sealed in same manner except that suction line insulation must be cut and pushed back before grommet can be slipped into place. (See Fig. 4.)

FIELD TUBING CONNECTIONS — All models are equipped with 3/8-in. liquid and 5/8-in. suction back seated service valves with mechanical flare field connections. Factory-supplied 3/8-in. to 3/8-in. and 5/8-in. to 5/8-in. flare-to-sweat adaptor tubes are provided. Field-supplied couplings are required for tubing packages exceeding 50-ft long-line applications.

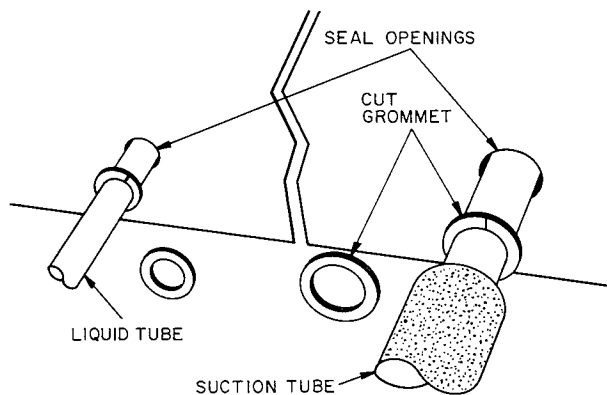

Fig. 4—Installing Grommets

Step 3—Test Unit

LEAK TESTING — No installation is complete until all field and factory joints have been checked for leaks.

1. Remove valve stem caps from both service valves and check to be sure valves are front seated (turned clockwise). Remove service port caps.
2. Attach gage manifold to service ports of service valves and purge hoses.
3. Pressurize evaporator coil and interconnecting refrigerant tubing with vapor from an external refrigerant cylinder of R-22 until the system and cylinder pressure are equalized.

NOTE: NEVER USE A UNIT CHARGE FOR LEAK TESTING.

4. Leak test with an electronic detector, a halide torch, or a liquid soap solution.
5. Recover refrigerant and repair any leaks.
6. If system is free of leaks, prepare unit for operation.

EVACUATION

1. Connect evacuation equipment to system gage manifold.
2. Evacuate system following appropriate steps for type of evacuation equipment used.
3. Pressurize system with refrigerant to 10 psig and open (turn counter-clockwise) both service valves.
4. Remove gage manifold. Replace valve stem and service port caps on both service valves.

Step 4—Make Electrical Connection

Field wiring must comply with local and national fire, safety and electrical codes. Voltage to unit must be within range of 253v to 187v. Refer to nameplate for other electrical data. Contact local power company for correction of improper line voltage.

▲ WARNING

According to NEC, ANSI/NFPA 70, and local codes, the cabinet must have an uninterrupted or unbroken ground, to minimize personal injury if an electrical fault should occur. The ground may consist of electrical wire or metal conduit when installed in accordance with existing electrical codes. Failure to follow this warning could result in an electric shock, fire, or death.

See unit's rating plate for recommended fuse size. When making electrical connections, provide clearance at unit for refrigerant piping connections.

BRANCH CIRCUIT DISCONNECT — Install a branch circuit disconnect per NEC of adequate size to handle unit starting current. Locate disconnect within sight from and readily accessible from unit, per Section 440-14 of the NEC.

LINE POWER LEADS

Extend leads from disconnect per NEC into unit through hole provided in service panel. (See Fig. 1.) Connect ground lead to ground lug in control box for safety. Connect line power leads to contactor screw terminals L1 and L2. (See Fig. 5 or 6.) Contactor terminals are approved for use with copper field wiring.

CONTROL POWER (24V) — Use furnace or fan coil transformer as 24v supply for system. Transformer must have a minimum capacity of 30 va. Bring control wiring through hole in unit service panel and connect to pigtailed from unit contactor. Contactor pigtailed are labeled Y and C. Refer to Fig. 5 or 6 for system control circuit connections.

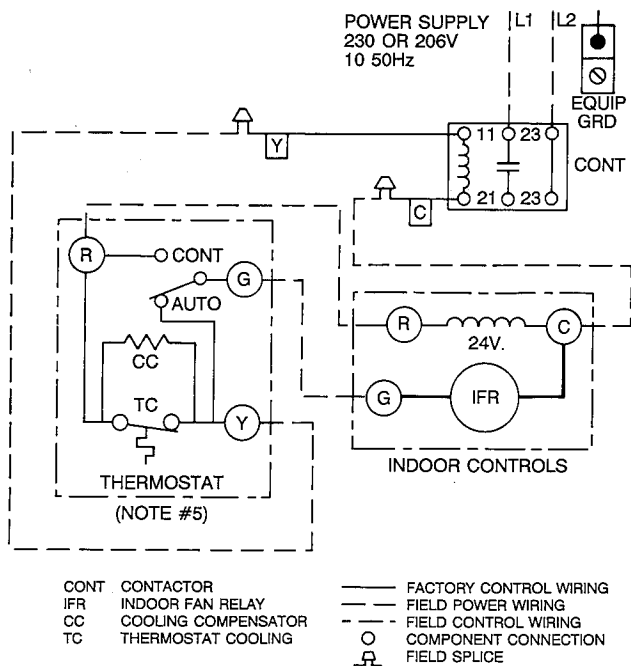

Fig. 5—Control Circuit Connection (018)

START-UP

Step 1—Start-up Procedure

1. Back seat (open) liquid and suction line service valves.
2. Set thermostat selector switch at OFF.
3. Set room thermostat to desired temperature.
4. Close electrical disconnects, energizing entire system.
5. Set room thermostat at COOL and fan switch as desired, FAN or AUTO. Operate unit for 15 minutes, then check system refrigerant charge. See Refrigerant Charging section.

Motors and controls operate satisfactory in the 253-v/187-v range.

Do not connect charging hoses during initial start-up procedure. (Loss of charge from this procedure may result in capacity reduction.) If necessary to add manifold gages for servicing, refer to the service manual for bypass method of returning charge to system.

Step 2—Sequence of Operation

When thermostat "calls for cooling," thermostat contacts close, energizing contactor holding coil from 24-v external power source. Contacts close, energizing compressor motor and condenser fan motor with supply voltage.

When thermostat is satisfied, contacts open, de-energizing contactor holding coil and, in turn, breaking supply voltage circuit. All motors should stop. In 024 size applications the lock-out relay prevents restart for up to 5 minutes. Refer to presale literature.

Step 3—Refrigerant Charging

Refer to information on unit rating plate.

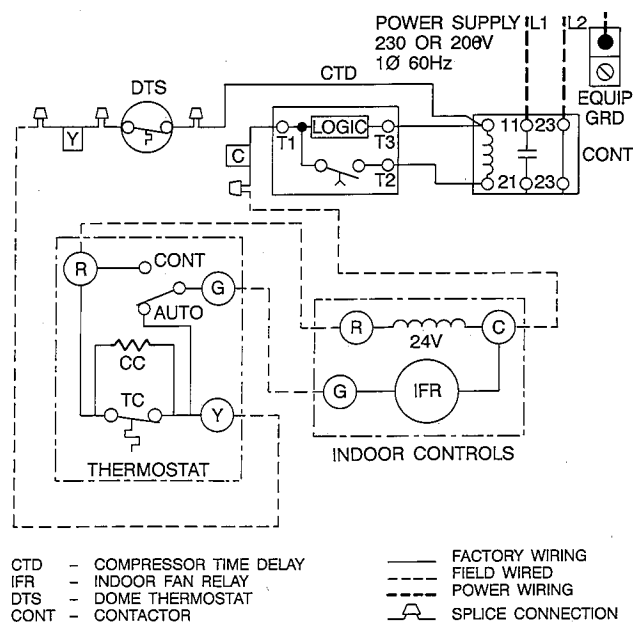

Fig. 6—Control Circuit Connection (024)

CAUTION

To prevent personal injury, wear safety glasses and gloves when handling refrigerant. Do not overcharge system. This can cause compressor flooding.

SERVICE

Access to all controls and unit components is through rear access panel.

WARNING

Because of possible damage to equipment or personal injury, maintenance should be performed by a trained technician. Consumer service is recommended only for filter cleaning/replacement.

Minimum maintenance to be performed:

1. Check condenser coil for cleanliness each month during cooling season. Clean as necessary but at least once at beginning of each season.
2. Check blower motor and wheel for cleanliness and proper lubrication each cooling season. Clean as needed.
3. Check electrical connections for tightness and controls for proper operation each cooling season. Service as necessary.

WARNING

As with any mechanical equipment, personal injury can result from sharp metal edges, etc., therefore, be careful when removing parts.

NOTE: Never operate unit more than 2 minutes with rear door removed as unit damage may result.

For continued high performance and to minimize possible equipment failure, periodic maintenance is essential. Consult dealer for proper maintenance frequency and availability of a maintenance contract.

Air for unit is drawn into front of unit at the bottom, and discharged out same side at the top. Keep air inlet and outlet louvers unplugged and clear of any obstructions at all times. Never cover unit or lean anything against it which might restrict airflow or cause hot air from upper louvers to recirculate into lower louvers. Keep trash and debris away from unit. Never stand on unit or use it as a support for ladders, etc.

Refrigerant tubing is easily crushed or crimped, therefore, do not hang or stand anything on it. Do not move unit after it has been installed, as this may crimp tubing and cause unit to malfunction. The ability to properly perform maintenance on this equipment requires certain mechanical skills and tools. If you do not possess these, contact dealer for maintenance.

⚠ WARNING

System contains oil and refrigerant under pressure. Do not use a torch when disconnecting refrigerant components. Wear safety goggles.

To disconnect refrigerant components:

1. Turn off electrical power to unit.
2. Recover refrigerant from unit.
3. Cut component connecting tubing with tubing cutter and remove component from unit.
4. Carefully unsweat tubing stubs from component. Oil may ignite when exposed to torch flame.

Step 1—Blower Wheel and Motor Removal

The blower assembly may easily be removed through the rear access panel in the following manner:

1. Shut off all power to the unit.
2. Loosen and remove 3 screws holding the rear access panel in place and remove rear access panel from unit. (See Fig. 7.)
3. Disconnect the 2 electrical leads from the blower motor to the compressor contactor.
4. Remove screws at top right and top left of blower retaining panel.
5. Remove entire blower assembly by lowering rear of assembly and lifting it toward you, so as to disengage it from slots in angles attached to sides of casing. Entire assembly can be removed through rear of unit.

NOTE: Assembly must be supported when screws are removed.

6. To change motor or wheel, loosen wheel setscrews with wrench. Remove 2 screws from blower housings. Remove 2 motor clamps and free assembly from panel.
7. Slide wheel and scroll from motor shaft.
8. Remove wheel from blower housing by removing 2 screws at top of scroll outlet and pushing wheel through outlet.
9. Reassemble in reverse procedure. Be sure blower wheel is centered in housings before entire blower panel assembly is placed back in the unit.
10. Connect the 2 electrical leads from the blower to the compressor contactor.
11. Replace the rear access panel and tighten the 3 screws.
12. Turn on power to unit.

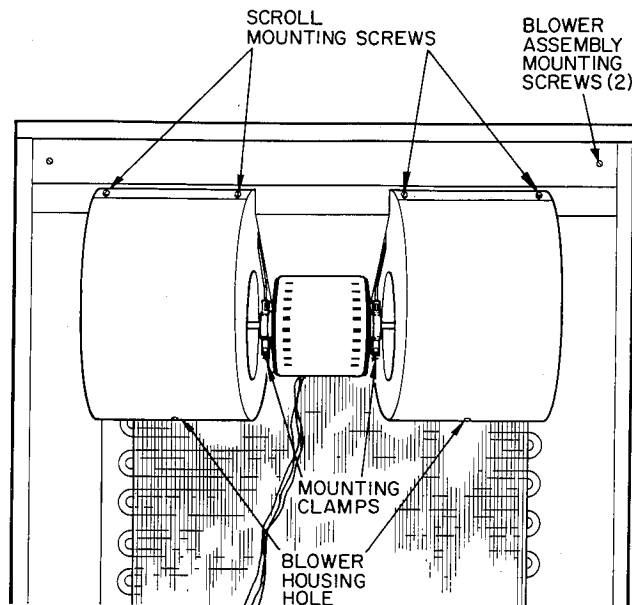

A88548

Fig. 7—Rear Access Panel Removed

Step 2—Electrical Controls and Wiring

Disconnect power to unit. Check all electrical connections for tightness. Tighten all screws on electrical connections. If any smoky or burned connections are observed, disassemble the connection(s), clean all parts, strip wire, reassemble properly (use new connector if old one is burned or corroded), and secure tightly. Electrical controls are difficult to check without proper instruments. Therefore, reconnect electrical power to unit and observe it through a complete operating cycle. If there are any performance problems in operating cycle, correct them.

Step 3—Refrigerant Circuit

This circuit is difficult to check for leaks without proper equipment. Therefore, if low cooling performance is suspected, dealer service is required.

Step 4—Compressor Protection

The 018 size unit is equipped with a **reciprocating compressor**, while the 024 size has a **scroll compressor**. In both applications the compressor motor is protected by an internal current and temperature-sensitive overload. Excessive current or temperature causes internal overload to open, giving the indication of an open circuit in the motor windings. The overload resets automatically when internal motor temperatures drop to a safe level (overloads may require up to 30 minutes to reset). When an internal overload is suspected of being open, check by using an ohmmeter or continuity tester.

The scroll compressor is equipped with a low-voltage dome thermostat that will interrupt low-voltage power to the contactor. The 024 size has time-delay relay (TDR) as standard equipment to ensure against short cycling which can cause reverse rotation on shutdown.

Step 5—Compressor Removal

Follow safety codes, and wear safety glasses and work gloves. Have quenching cloth available for Step 7 below.

1. Shut off power to unit. Remove rear access panel.

2. Remove refrigerant from system.

⚠ CAUTION

Do not vent refrigerant to atmosphere. Recover during system repair or final unit disposal.

3. Disconnect compressor wiring at compressor terminal box.
4. Using a tubing cutter, cut suction and discharge (hot gas) lines at convenient place near compressor for easy reassembly to new compressor.
5. Remove compressor hold-down bolts and lift compressor out.
6. Remove mounting grommets from old compressor and install on new compressor.
7. Carefully unbrazed suction and discharge line piping stubs from old compressor. If oil vapor in piping stubs ignites, use quenching cloth. Braze piping stubs onto new compressor.
8. Install new compressor in unit. Braze suction and discharge lines to compressor piping stubs at points where cut (Step 4),

using field-supplied copper slip couplings. Ensure that compressor hold-down bolts are in place. Connect wiring.

9. Clean system. Add new liquid line filter drier.
10. Evacuate and recharge unit.

Step 6—Cleaning Condenser Coil

Disconnect electrical power before removing access panel. Remove rear access panel. Since air is drawn into front of unit at bottom and discharged out the same side at the top, dirt collects on front of coil and unit. To clean coil, flush out from inside of unit with a high velocity stream of water. Be careful not to damage fins. If coil is coated with oil or grease, clean it with a mild detergent or an approved coil-cleaning agent, then rinse with clear water. Do not allow water to get into compressor and unit control box. Cabinet is equipped with drain holes at bottom of front edge. Be sure holes are unclogged and free to drain.

Trouble Analysis Chart

SYMPTOM	CAUSE	REMEDY
Compressor and condenser fan do not start	Power failure	Call power company
	Fuse blown or circuit breaker tripped	Replace fuse or reset circuit breaker
	Defective thermostat contactor or control relay	Replace component
	Low-line voltage	Determine cause and correct
	Incorrect or faulty wiring	Check wiring diagram and rewire correctly
	Thermostat setting too high	Lower thermostat setting below room temperature
Compressor does not start, but condenser fan runs	Faulty wiring or loose connections in compressor circuit	Check wiring; repair or replace
	Compressor motor burned out, seized, or internal overload open	Replace compressor and determine cause
	Defective run capacitor	Determine cause and replace
Compressor cycles (other than normally satisfying thermostat)	Refrigerant overcharged or undercharged	Remove refrigerant, evacuate system, and recharge
	Defective compressor	Determine cause and replace
	Low-line voltage	Determine cause and correct
	Blocked condenser	Determine cause and correct
	Defective run capacitor	Determine cause and replace
	Defective thermostat	Replace thermostat
	Faulty condenser fan motor or capacitor	Replace
	Restriction in refrigerant system	Locate restriction and remove
Compressor operates continuously	Unit undersized for load	Decrease load or increase unit size
	Thermostat setting too low	Raise thermostat setting above room temperature
	Low refrigerant charge	Locate leak; repair and recharge
	Leaking valves in compressor	Replace compressor
	Air in system	Remove refrigerant, evacuate system, recharge
	Condenser coil dirty or restricted	Clean coil or remove restriction
Excessive head pressure	Dirty condenser coil	Clean coil
	Refrigerant overcharged	Remove excess refrigerant
	Air in system	Remove refrigerant, evacuate system, and recharge
	Condenser air restricted or air short cycling	Eliminate cause
Head pressure too low	Low refrigerant charge	Locate leak; repair and recharge
	Compressor valves leaking	Replace compressor
	Restriction in liquid tube	Remove restriction
Excessive suction pressure	High-heat load	Check for source and eliminate
	Compressor valves leaking	Replace compressor
	Refrigerant overcharged	Remove excess refrigerant
Suction pressure too low	Low refrigerant charge	Locate leak; repair and recharge
	Metering device or low side restricted	Remove source or restriction
	Low evaporator air	Increase air
	Temperature too low in conditioned area	Reset thermostat

Manufacturer reserves the right to discontinue, or change at any time, specifications or designs without notice and without incurring obligations.

Free Manuals Download Website

<http://myh66.com>

<http://usermanuals.us>

<http://www.somanuals.com>

<http://www.4manuals.cc>

<http://www.manual-lib.com>

<http://www.404manual.com>

<http://www.luxmanual.com>

<http://aubethermostatmanual.com>

Golf course search by state

<http://golfingnear.com>

Email search by domain

<http://emailbydomain.com>

Auto manuals search

<http://auto.somanuals.com>

TV manuals search

<http://tv.somanuals.com>