

CHICAGO welding
ELECTRIC® systems

BANDSAW BLADE WELDER

Model 3663

SET UP AND OPERATING INSTRUCTIONS



Diagrams within this manual may not be drawn proportionally.

Due to continuing improvements, actual product may differ slightly from the product described herein.

Distributed exclusively by Harbor Freight Tools®.

3491 Mission Oaks Blvd., Camarillo, CA 93011

Visit our website at: <http://www.harborfreight.com>



**Read this material before using this product.
Failure to do so can result in serious injury.
SAVE THIS MANUAL.**

Copyright© 2003 by Harbor Freight Tools®. All rights reserved. No portion of this manual or any artwork contained herein may be reproduced in any shape or form without the express written consent of Harbor Freight Tools.

For technical questions or replacement parts, please call 1-800-444-3353.

Revised 03d, 07k

SPECIFICATIONS

Power Requirements	220 V~, 1-Phase, 60 Hz, 6 A (Only use on a 20 amp circuit)
Welding Current	280 A
Welding Blade Sizes	1/8" to 1/2"
Maximum Jaw Movement	.137"

Note: Grinder not included.

Note: Performance of this tool (if powered by line voltage) may vary depending on variations in local line voltage. Extension cord usage may also affect tool performance.

Save This Manual

You will need the manual for the safety warnings and precautions, assembly instructions, operating and maintenance procedures, parts list and diagram. Keep your invoice with this manual. Write the invoice number on the inside of the front cover. Keep the manual and invoice in a safe and dry place for future reference.

SAFETY WARNINGS AND PRECAUTIONS

WARNING: When using tool, basic safety precautions should always be followed to reduce the risk of personal injury and damage to equipment.

Read all instructions before using this tool!

1. **Keep work area clean.** Cluttered areas invite injuries.
2. **Observe work area conditions.** Do not use the Welder in damp or wet locations. Don't expose to rain. Keep work area well lighted. Do not use electrically powered tools in the presence of flammable gases or liquids.
3. **Keep children away.** Children must never be allowed in the work area. Do not let them handle machines, tools, or extension cords.
4. **Store idle equipment.** When not in use, tools must be stored in a dry location to inhibit rust. Always lock up tools and keep out of reach of children.
5. **Use the right tool for the job.** Do not attempt to force a small tool or attachment to do the work of a larger industrial tool. There are certain applications for which this tool was designed. It will do the job better and more safely at the rate for which it was intended. Do not modify this tool and do not use this tool for a purpose for which it was not intended.
6. **Dress properly.** Do not wear loose clothing or jewelry as they can be caught in moving parts. Protective, electrically non-conductive clothes and non-skid footwear are recommended when working. Wear restrictive hair covering to contain long hair. **Always wear heavy-duty leather gloves when handling bandsaw blades.**

Inhalation Hazard

Welding/Plasma Cutting Produces TOXIC FUMES and GASSES.



Exposure to welding or cutting gasses can increase the risk of developing certain cancers, such as cancer of the larynx and lung cancer. Also, some diseases that may be linked to exposure to welding or plasma cutting gasses or fumes are:

- Early onset of Parkinson's Disease
- Heart Disease
- Damage to the reproductive organs
- Ulcers
- Inflammation of the small intestine or stomach
- Kidney damage
- Respiratory diseases such as emphysema, bronchitis or pneumonia



Safety precautions, such as using natural or forced air ventilation and wearing an ANSI approved respirator, are **ESSENTIAL** to reduce the risk of developing the above illnesses.

7. **Use eye and ear protection.** Always wear ANSI approved impact safety goggles. Wear a full face shield if you are producing metal filings. Wear an ANSI approved dust mask or respirator when working around metal and chemical dusts and mists.
8. **Do not overreach.** Keep proper footing and balance at all times. Do not reach over or across running machines.
9. **Maintain tools with care.** Keep tools clean for better and safer performance. Follow instructions for lubricating and changing accessories. Inspect tool cords periodically and, if damaged, have them repaired by an authorized technician. The handle must be kept clean, dry, and free from oil and grease at all times.
10. **Disconnect power.** Unplug tool when not in use.
11. **Avoid unintentional starting.** Be sure the buttons are not depressed when not in use and before plugging in.
12. **Stay alert.** Watch what you are doing, use common sense. Do not operate any tool when you are tired.
13. **Check for damaged parts.** Before using any tool, any part that appears damaged should be carefully checked to determine that it will operate properly and perform its intended function. Check for alignment and binding of moving parts; any broken parts or mounting fixtures; and any other condition that may affect proper operation. Any part that is damaged should be properly repaired or replaced by a qualified technician. Do not use the tool if any button does not turn On and Off properly.
14. **Guard against electric shock.** Prevent body contact with grounded surfaces such as pipes, radiators, ranges, and refrigerator enclosures.
15. **Replacement parts and accessories.** When servicing, use only identical replacement parts. Use of any other parts will void the warranty. Only use accessories intended for use with this tool. Approved accessories are available from Harbor Freight Tools.
16. **Do not operate tool is under the influence of alcohol or drugs.** Read warning labels if taking prescription medicine to determine if your judgement or reflexes are impaired while taking drugs. If there is any doubt, do not operate the Welder.

17. **Use proper size and type extension cord.** If an extension cord is required, it must be of the proper size and type to supply the correct current to the tool without heating up. Otherwise, the extension cord could melt and catch fire, or cause electrical damage to the tool. This tool requires use of an extension cord of **20 amps** capability (up to 50 feet), with wire size rated at **12 AWG**. Longer extension cords require larger size wire. If you are using the tool outdoors, use an extension cord rated for outdoor use (signified by "WA" on the jacket).
18. **Maintenance.** For your safety, maintenance should be performed regularly by a qualified technician.
19. This product, when used for welding and similar applications, produces chemicals known to the State of California to cause cancer and birth defects (or other reproductive harm). (California Health & Safety Code § 25249.5, et seq.)
20. The warnings, cautions, and instructions discussed in this instruction manual cannot cover all possible conditions and situations that may occur. It must be understood by the operator that common sense and caution are factors which cannot be built into this product, but must be supplied by the operator.

UNPACKING

When unpacking, check to make sure that the item is intact and undamaged. If any parts are missing or broken, please call Harbor Freight Tools at the number shown on the cover of this manual as soon as possible.

ASSEMBLY

This step should only be performed by a licensed electrician. Acquire an appropriate 220 V~, 1-Phase plug to fit in the electrical outlet. Connect the plug, making sure that the black wire is the energized (hot) lead, the white wire is the other energized (hot) lead, and the green wire is the ground lead.

See the wiring diagram on page 8.

FIGURE 1

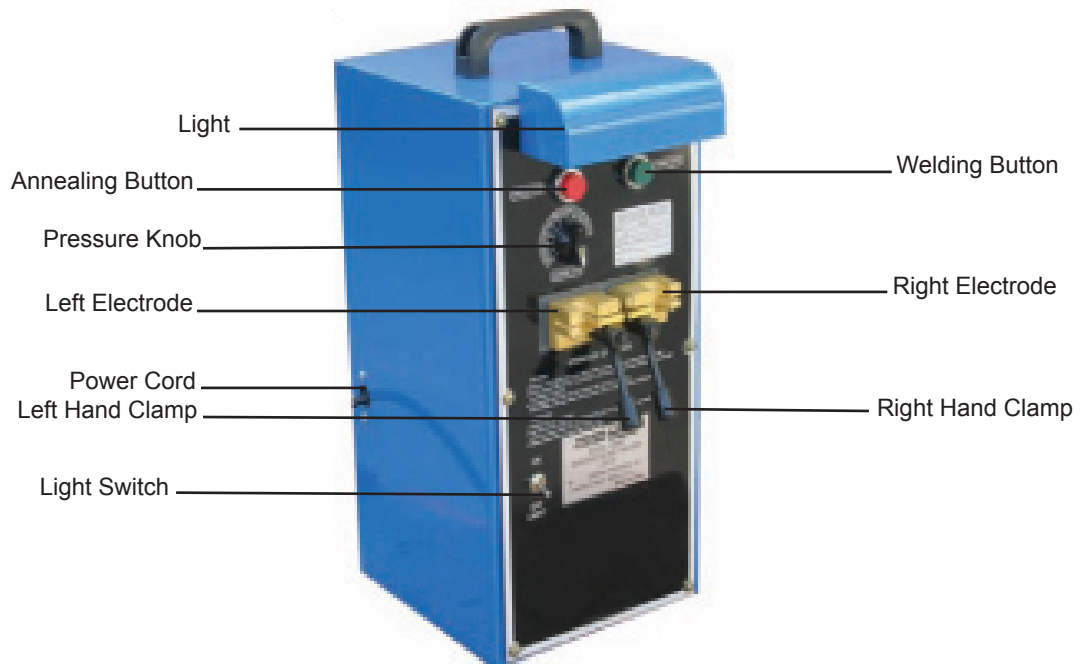

OPERATION

This Bandsaw Blade Welder is used to weld saw blades between 1/8 and 1/2 inches in width.

Additional Warnings!

1. Make sure the Welding and Annealing Buttons are not depressed before plugging in the unit.
2. Never leave the welder unattended while running.
3. Always unplug before servicing. All internal maintenance should be performed by an authorized service technician.
4. **Sparks are generated while welding. Situate the welder far away from any flammable materials. Work in a well-ventilated area.**

Note: This unit does not have a grinder attachment.

WARNING! Handle blades with extreme care. They flex and twist easily, making them extremely dangerous. Always wear heavy-duty leather gloves when handling bandsaw blades.

Saw blade preparation

1. Wearing heavy-duty leather gloves, use a metal table shear (not included) to trim 1/4" off each end of the saw blade.

Note: The ends must be cut perfectly square to attain a full width weld. The cut should be made in an area between the blade's teeth (especially with larger blades). If hand shears (not included) are used to cut the blade, it may be necessary to file the ends until they are square. Use a square (tool, not included) to make sure the blade ends are 90°. There should be no taper on the very end of the blade.

2. Using a fine emery cloth (not included), lightly clean both ends (and flat surfaces near the ends) of the saw blade. Remove all burrs. Completely clean off all dirt, coatings, and oil.

Welding

Refer to FIGURES and the Assembly Drawing on page 9.

1. Verify that the plug is not plugged into the power outlet.

FIGURE 2



**Pressure Knob
(12)**

FIGURE 3

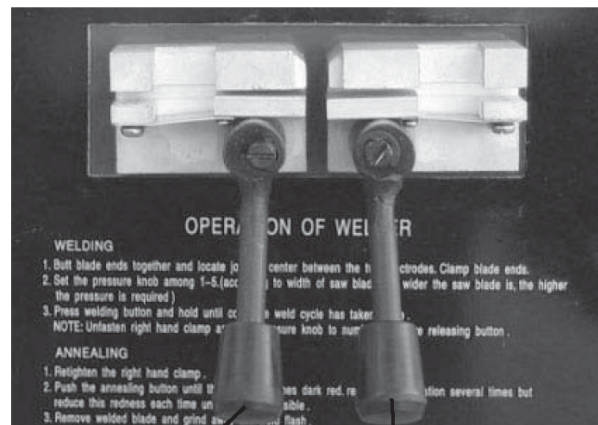

Left Hand Clamp (14)

Right Hand Clamp (6)

2. Turn the Pressure Knob (12) to zero. See FIGURE 2. When the Pressure Knob (12) is turned to zero, the Right Electrode (5) will separate from the Left Electrode (13).

3. Loosen both of the clamp handles (Left Hand Clamp (14) and Right Hand Clamp (6)). See FIGURE 3.
4. Place one end of the saw blade (not included) under the Left Electrode (13). See FIGURE 4 on page 6. Make sure it is aligned squarely and the teeth are facing back. The saw blade end should protrude 1/4" out of the clamp, toward the center.

FIGURE 4



FIGURE 5

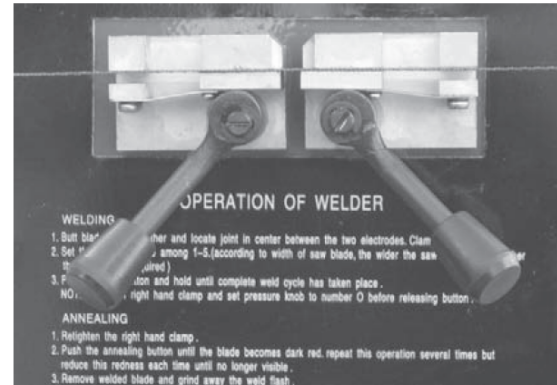

5. Tighten the Left Hand Clamp (14). See FIGURE 4.
6. Repeat steps 4 and 5 on the Right Electrode (5) and Right Hand Clamp (6) with the other end of the saw blade. See FIGURE 5.
7. To butt up the ends of the blades, turn the Pressure Knob (12) to the setting based on the blade width you are welding, i.e. if you are welding a 1/4" blade, adjust the knob to number 2. See FIGURE 2 on page 5. The wider the saw blade, the higher the Pressure Knob (12) should be set.
8. Verify that the saw blades align squarely, front to back, and that the two ends butt together with no space in-between. If they do not, remove the saw blades and recut the ends to make them more square.
9. Put on your safety glasses, respirator, and gloves approved for welding.
10. Plug the unit in.
11. Press and hold the green Welding Button (4) until the weld cycle is complete. If popping occurs, or holes are created during the welding process, the blade ends were not butted together correctly. Unplug the Welder and prepare the saw blade ends again.
12. With the Welding Button (4) still pressed, loosen the Right Hand Clamp (6) and turn the Pressure Knob (12) counterclockwise to zero. Then, release the Welding Button (4). See FIGURE 6.

FIGURE 6



Annealing the Weld

Note: The annealing process tempers and toughens the blade, reducing brittleness.

1. Retighten the Right Hand Clamp (6). See Figure 7.
2. Press and hold the red Annealing Button (11) until the blade becomes dark red. Release the Annealing Button (11) after a few seconds.
3. Repeat pressing and releasing (pulsating action) the Annealing Button (11) (while reducing the annealing time) several times until the redness is no longer visible.
4. Let the saw blade cool for at least five minutes, then unplug the plug and remove the blade from the Welder.
5. Use an 8 inch mill bastard file (not included) to file off the welding flash. If the flash is too hard and will not easily file off, repeat the annealing process.
6. File all of the flashing from around the weld, being careful not to undercut the weld surface in comparison to the rest of the blade.
7. Test the weld by carefully bending the blade to a 4 inch radius to see if it breaks.

Note: **Test the repaired saw blade.** After repairing the blade, carefully install it on the bandsaw following the instructions and safety warnings provided in the instruction manual of the bandsaw. Once the blade is installed, make sure the guards and any cabinet doors on the tool are in the closed/safe position. Run the saw for 2-3 minutes. Then, stop the saw, unplug it, and check the weld visually before you begin cutting an actual workpiece. Do not continue if the weld shows signs of cracking or breaking.

FIGURE 7



MAINTENANCE

WARNING! Unplug welder before performing any maintenance.

1. When not in use, cover and store the Welder in a clean, dry location.
2. Periodically, open and use fine grit sandpaper to clean the carbon residue from the inside surfaces of the terminal clamps.
3. Always unplug before servicing. All internal maintenance should be performed by a qualified service technician.

Wiring Diagram

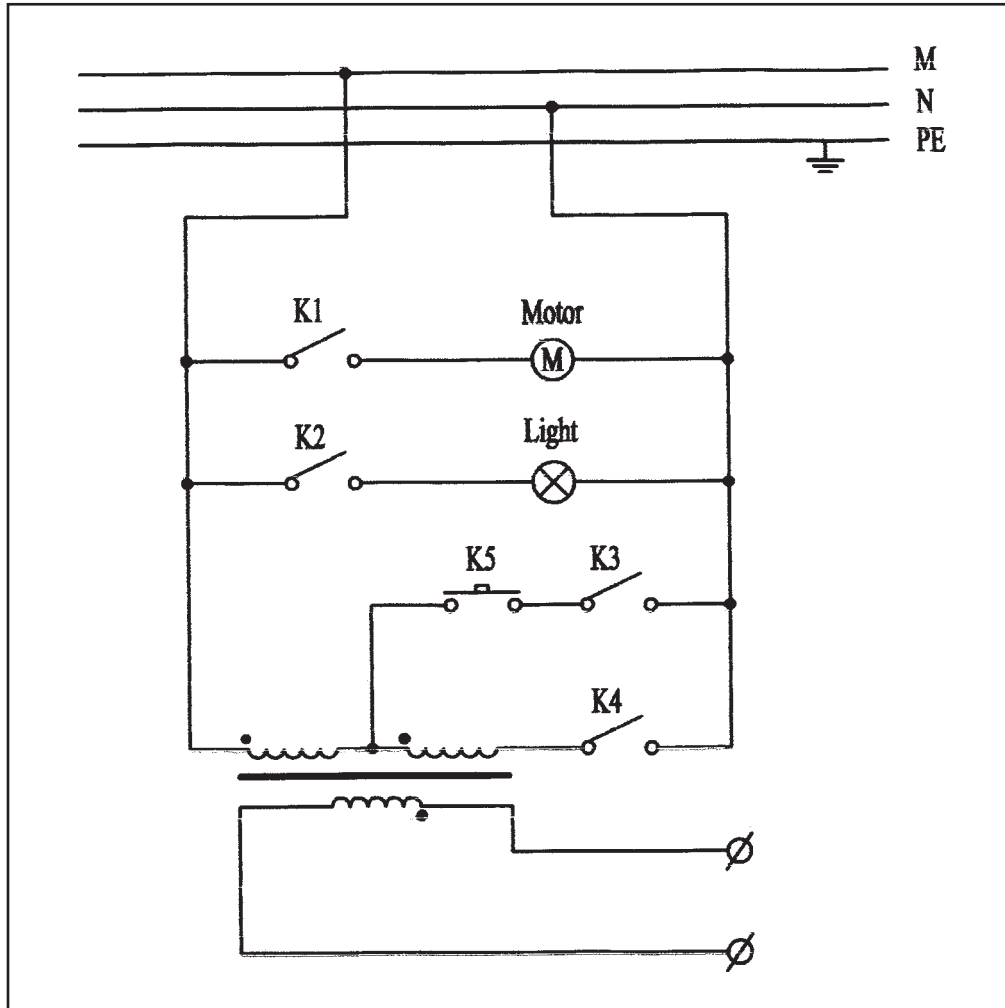

FRONT PANEL PARTS LIST AND DIAGRAM

Part	Description	Part	Description	Part	Description
1	Handle	6	Right Hand Clamp	14	Left Hand Clamp
2	Light Mantle	10	Case	15	Light Switch
3	Base Frame	11	Annealing Button	16	Line Cord (without plug)
4	Welding Button	12	Pressure Knob		
5	Right Electrode	13	Left Electrode		

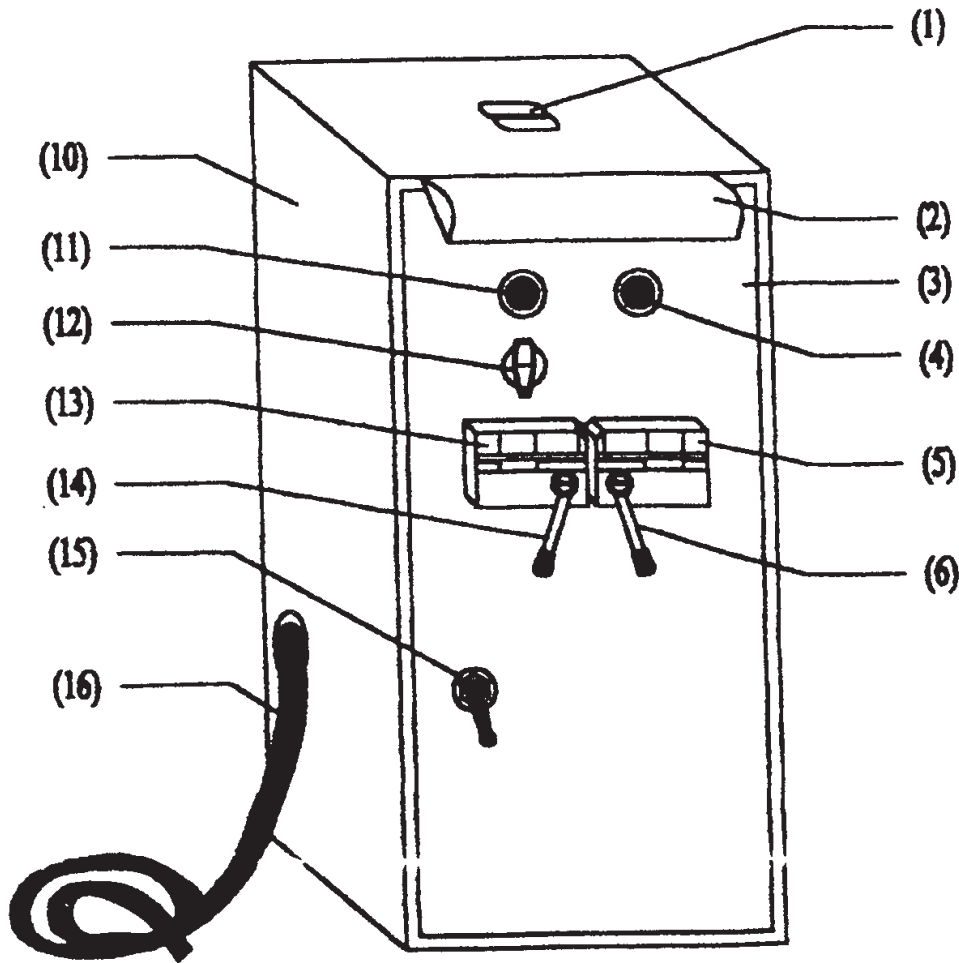

PLEASE READ THE FOLLOWING CAREFULLY

THE MANUFACTURER AND/OR DISTRIBUTOR HAS PROVIDED THE PARTS DIAGRAM IN THIS MANUAL AS A REFERENCE TOOL ONLY. NEITHER THE MANUFACTURER NOR DISTRIBUTOR MAKES ANY REPRESENTATION OR WARRANTY OF ANY KIND TO THE BUYER THAT HE OR SHE IS QUALIFIED TO MAKE ANY REPAIRS TO THE PRODUCT OR THAT HE OR SHE IS QUALIFIED TO REPLACE ANY PARTS OF THE PRODUCT. IN FACT, THE MANUFACTURER AND/OR DISTRIBUTOR EXPRESSLY STATES THAT ALL REPAIRS AND PARTS REPLACEMENTS SHOULD BE UNDERTAKEN BY CERTIFIED AND LICENSED TECHNICIANS AND NOT BY THE BUYER. THE BUYER ASSUMES ALL RISK AND LIABILITY ARISING OUT OF HIS OR HER REPAIRS TO THE ORIGINAL PRODUCT OR REPLACEMENT PARTS THERETO, OR ARISING OUT OF HIS OR HER INSTALLATION OF REPLACEMENT PARTS THERETO.

Note: Some parts are listed and shown for illustration purposes only and are not available individually as replacement parts.

PARTS LIST

Part	Description
1	Ringent Circle
2	Defection Axes
3	Cover of Deflection Axes
4	Left Electrode
5	Right Electrode
6	Lamp
7	Lamp Holder
8	Lamp Shield
9	Nut
10	Knob
11	Bolt
12	Nameplate
13	Panel
14	Red Button
15	Green Button
16	Base of Deflection Wheel
17	Bolt
18	Deflection Wheel
19	Washer
20	Axes
21	Spring Washer
22	Nut
23	Batten
24	Bolt
25	Short Spring
26	Long Spring

Part	Description
27	Bolt
28	Spring Washer
29	Washer
30	Base of Spring
31	Base of Spot Switch
32	Spot Switch
33	Connection
34	Base of Connection
35	Main Transformer
36	Nut
37	Spring Washer
38	Washer
39	Support Shelf of Transformer
40	Bolt
41	Base of Sliding Block
42	Inner-Hexagonal Bolt
43	Iron Wedge
44	Copper Block
46	Bolt
47	Label
48	Button Switch
49	Nail
50	Connection Piece
51	Copper Pressure Block
52	Handle

ASSEMBLY DRAWING

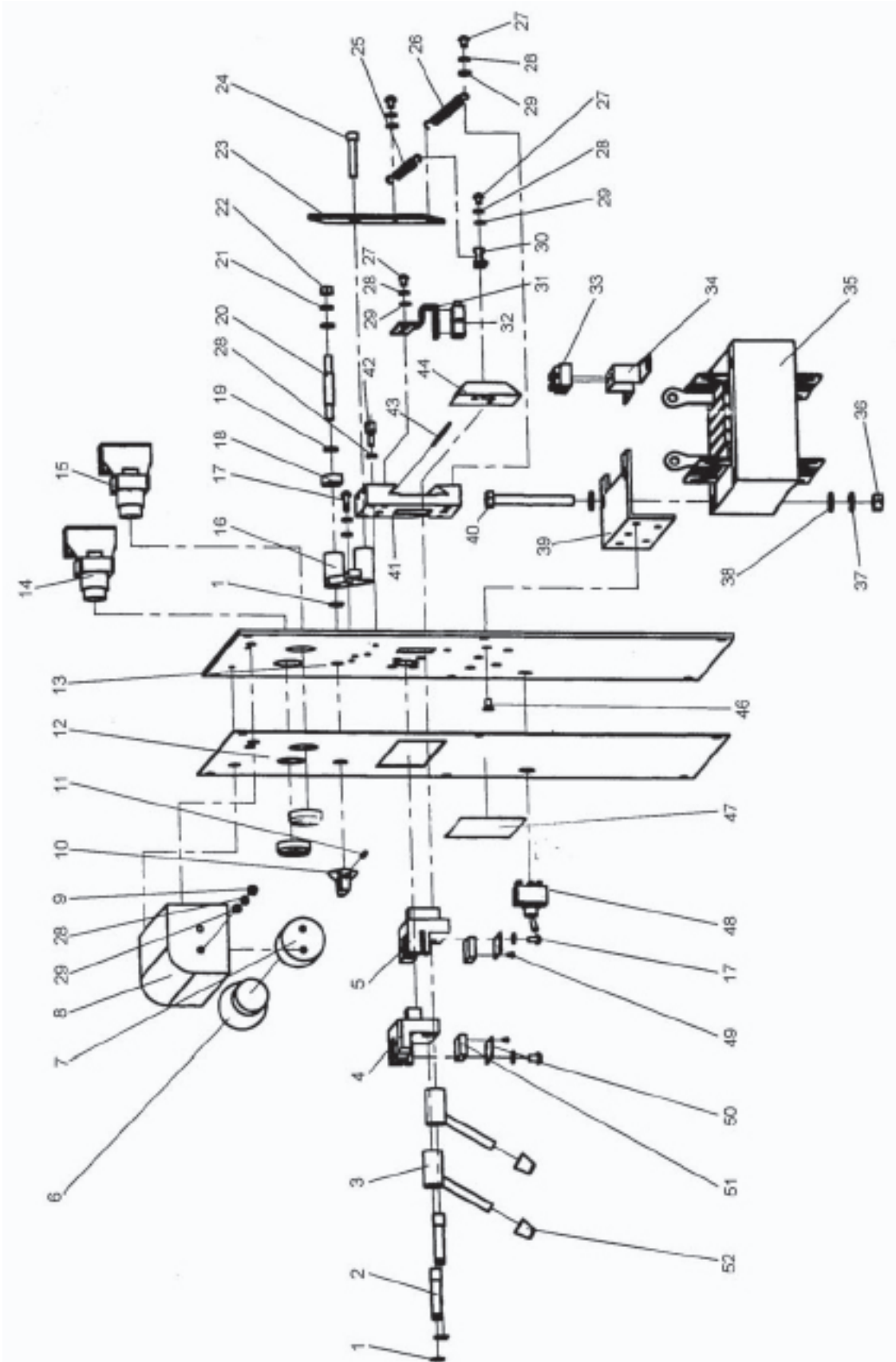

LIMITED 1 YEAR / 90 DAY WARRANTY

Harbor Freight Tools Co. makes every effort to assure that its products meet high quality and durability standards, and warrants to the original purchaser that for a period of ninety days from date of purchase that the torch, liner, wire feed mechanism (if applicable), welding clamps, electrode holders, cables and accessories packed with the welder are free of defects in materials and workmanship. **This Limited 90 Day/1 Year Warranty shall not apply to consumable parts such as tips, welding wire, and gas nozzles.** Harbor Freight Tools also warrants to the original purchaser, for a period of one year from date of purchase, that the transformer and rectifier are free from defects in materials and workmanship (90 days if used by a professional contractor or if used as rental equipment). This warranty does not apply to damage due directly or indirectly to misuse, abuse, negligence or accidents, repairs or alterations outside our facilities, normal wear and tear, or to lack of maintenance. We shall in no event be liable for death, injuries to persons or property, or for incidental, contingent, special or consequential damages arising from the use of our product. Some states do not allow the exclusion or limitation of incidental or consequential damages, so the above limitation of exclusion may not apply to you. THIS WARRANTY IS EXPRESSLY IN LIEU OF ALL OTHER WARRANTIES, EXPRESS OR IMPLIED, INCLUDING THE WARRANTIES OF MERCHANTABILITY AND FITNESS.

To take advantage of this warranty, the product or part must be returned to us with transportation charges prepaid. Proof of purchase date and an explanation of the complaint must accompany the merchandise. If our inspection verifies the defect, we will either repair or replace the product at our election or we may elect to refund the purchase price if we cannot readily and quickly provide you with a replacement. We will return repaired products at our expense, but if we determine there is no defect, or that the defect resulted from causes not within the scope of our warranty, then you must bear the cost of returning the product.

This warranty gives you specific legal rights and you may also have other rights which vary from state to state.

3491 Mission Oaks Blvd. • PO Box 6009 • Camarillo, CA 93011 • (800) 444-3353

Free Manuals Download Website

<http://myh66.com>

<http://usermanuals.us>

<http://www.somanuals.com>

<http://www.4manuals.cc>

<http://www.manual-lib.com>

<http://www.404manual.com>

<http://www.luxmanual.com>

<http://aubethermostatmanual.com>

Golf course search by state

<http://golfingnear.com>

Email search by domain

<http://emailbydomain.com>

Auto manuals search

<http://auto.somanuals.com>

TV manuals search

<http://tv.somanuals.com>