

# **BARCO**

**HOME CINEMA**

## **BARCO CINE7**

**R9010040  
R9010050**

## **OWNERS MANUAL**

**Barco nv Home Cinema**

Noordlaan 5, B-8520 Kuurne

Phone: +32 56.36.84.30

Fax: +32 56.36.88.62

E-mail: [salesassistantht.bci@barco.com](mailto:salesassistantht.bci@barco.com)

Visit us at the web: [www.homecinema.barco.com](http://www.homecinema.barco.com)

Printed in Belgium

## **Changes**

Barco provides this manual "as is" without warranty of any kind, either expressed or implied, including but not limited to the implied warranties or merchantability and fitness for a particular purpose. Barco may make improvements and/or changes to the product(s) and/or the program(s) described in this publication at any time without notice.

This publication could contain technical inaccuracies or typographical errors. Changes are periodically made to the information in this publication; these changes are incorporated in new editions of this publication.

## **Copyright ©**

All rights reserved. No part of this document may be copied, reproduced or translated. It shall not otherwise be recorded, transmitted or stored in a retrieval system without the prior written consent of BARCO.

## **Trademarks**

Brand and product names mentioned in this manual may be trademarks, registered trademarks or copyrights of their respective holders. All brand and product names mentioned in this manual serve as comments or examples and are not to be understood as advertising for the products or their manufactures.



# TABLE OF CONTENTS

<b>1. Safety Instructions</b> .....	<b>5</b>
1.1 Safety Instructions .....	5
<b>2. AC Power</b> .....	<b>9</b>
2.1 AC Power Cord Connection .....	9
2.2 AC Power Voltage .....	9
2.3 Switching ON/OFF .....	9
<b>3. Source Connections</b> .....	<b>11</b>
3.1 Input Locations .....	11
3.2 Connecting a Composite Video source .....	12
3.3 Connecting a S-Video source .....	13
3.4 Connecting a RGB Analog source with composite sync .....	15
3.5 Connecting a RGB Analog source with Tri level composite sync .....	16
3.6 Connecting a Component source with composite sync .....	17
3.7 Connecting a Component source with Tri level composite sync .....	18
3.8 RS232 Connection .....	19
3.9 Communication Port for Communication With Peripherals .....	20
3.10 12V Trigger output .....	20
<b>4. Getting Started</b> .....	<b>21</b>
4.1 Batteries .....	21
4.1.1 Battery installation .....	21
4.1.2 Battery replacement .....	21
4.2 RCU & Local keypad .....	22
4.3 Terminology overview .....	23
4.4 Switching on the projector .....	25
4.5 Using the RCU .....	26
4.6 Projector Address .....	27
4.6.1 Controlling the projector .....	27
4.6.2 Displaying and Programming addresses .....	28
4.7 Controlling the projector .....	28
4.7.1 Input selection .....	28
4.7.2 Picture controls .....	28
<b>5. Start up of the adjustment mode</b> .....	<b>31</b>
5.1 How to start up the adjustment mode .....	31
5.2 How to adjust an analog control .....	32
<b>6. Main Menu</b> .....	<b>33</b>
6.1 Main Menu Overview .....	33
6.2 Image Control .....	33
6.2.1 Starting up the image controls .....	34
6.2.2 Line Multiplier .....	34
6.2.2.1 Changing the Multiplier setting .....	34
6.2.2.2 Multiplier mode .....	35
6.2.2.3 Motion Processing On/Off .....	36
6.2.2.4 Video Equalizing .....	36
6.2.2.5 Noise Reduction .....	37
6.2.2.6 Contrast Enhancement .....	38
6.2.3 Color Adjust, Color temperature set up .....	38
6.2.4 Format Select .....	39
6.2.4.1 Selecting a Format .....	39
6.2.4.2 Adding a name to a Format .....	39
6.2.4.3 Storing the settings to a new Format .....	40
6.3 IRIS Control .....	40
6.3.1 Starting up the IRIS Controls .....	41
6.3.2 IRIS Touch Up .....	41
6.3.3 IRIS Auto Converge .....	41
6.3.4 IRIS Full Alignment .....	42
6.4 Sound Control .....	42
6.5 Function Keys .....	43
6.6 Service Menus .....	43
<b>7. Entering the service menus</b> .....	<b>45</b>
7.1 The Adjustment menus .....	45
7.2 Password Protection .....	46
<b>8. Random Access Adjustment Mode</b> .....	<b>49</b>
8.1 Introduction .....	49
8.2 Random Access Overview .....	50
8.3 Selecting Setup Pattern .....	51
8.4 Random Access mode selection menu .....	52

8.5	Picture Tuning.....	52
8.5.1	Starting up Picture Tuning .....	53
8.5.2	Color Balance .....	53
8.5.2.1	Selecting the Color Balance .....	53
8.5.2.2	Set a Fixed Color Balance.....	54
8.5.2.3	Custom Color Balance, White Balance adjustment .....	54
8.5.2.4	Custom Color Balance, Black Balance adjustment.....	55
8.5.3	Sync mode: Fast/Slow .....	55
8.5.4	Decoding.....	55
8.5.5	Port 2 Video/S-Video (Optional) .....	56
8.5.6	Peaking .....	56
8.5.7	Line Multiplier Settings .....	57
8.5.7.1	Starting up Line Multiplier settings .....	57
8.5.7.2	Switching the multiplier ON/OFF .....	58
8.5.7.3	Motion Processing On/Off .....	58
8.5.7.4	Output Mode .....	59
8.5.7.5	Video Equalizing .....	59
8.5.7.6	Noise Reduction .....	60
8.5.7.7	Contrast Enhancement .....	60
8.5.7.8	Split Screen On/Off .....	61
8.5.7.9	Advanced Settings .....	61
8.5.7.9.1	Starting Up Advanced Settings .....	62
8.5.7.9.2	Time Base Correction .....	62
8.5.7.9.3	Luminance Delay .....	62
8.5.7.9.4	Vertical Sync Reference .....	63
8.5.7.9.5	Clamp Gating .....	63
8.5.7.10	Limo Pro Options .....	64
8.5.7.10.6	Starting Up Limo Pro Options.....	64
8.5.7.10.7	Coring.....	64
8.5.7.10.8	LTI .....	65
8.5.7.10.9	CTI.....	66
8.5.7.10.10	Factory Presets .....	67
8.6	Geometry Adjustments .....	68
8.6.1	Starting Up Geometry .....	68
8.6.2	Horizontal Phase Adjustment .....	68
8.6.3	Raster Shift Adjustment .....	69
8.6.4	Left-Right (East-West) Adjustment .....	70
8.6.5	Top-Bottom (Nord-South) Adjustment .....	73
8.6.6	Size Adjustment .....	76
8.6.7	Vertical Linearity Adjustment.....	78
8.6.8	Blanking Adjustments .....	79
8.7	Convergence Adjustment.....	80
8.7.1	Starting Up Convergence .....	80
8.7.2	Convergence Adjustment .....	81
<b>9.</b>	<b>Service Mode.....</b>	<b>83</b>
9.1	Introduction.....	83
9.2	Service Mode Overview .....	84
9.3	Projector Set up .....	84
9.3.1	Starting Up Projector Set-Up.....	85
9.3.2	Identification .....	85
9.3.3	Total Run Time .....	85
9.3.4	Change Password.....	86
9.3.5	Change Language.....	86
9.3.6	Change Projector Address .....	87
9.3.7	Change Baudrate.....	87
9.3.8	Power Up Mode Operating/Stand-By.....	88
9.3.9	Common Address .....	88
9.3.10	Barco Logo .....	89
9.4	Memory Management.....	90
9.4.1	Starting Up Memory Management.....	91
9.4.2	Copy a Block .....	91
9.4.3	Delete a Block .....	91
9.4.4	Delete All Blocks .....	92
9.4.5	All Settings to Midposition.....	92
9.4.6	R & B Convergence to Midposition .....	93
9.4.7	Green Convergence to Midposition.....	94
9.5	Common Settings .....	95
9.5.1	Starting Up Common Settings .....	95
9.5.2	G2 Adjustment.....	95
9.5.3	CRT Run In Cycle .....	95
9.5.4	Projector Warm Up .....	96
9.5.5	Memory Banks.....	96
9.6	I2C Diagnostics .....	97

---

<b>10. Programmable Function Keys .....</b>	<b>99</b>
10.1 Programming a Function Keys .....	99
10.2 Different function which can be programmed .....	100
<b>11. Messages, Warnings and Failures .....</b>	<b>101</b>
11.1 Messages .....	101
11.2 Warnings .....	101
11.3 Failures .....	102
<b>A. Source Numbers 81 — 86 and 91 — 96 .....</b>	<b>103</b>
A.1 Projector without any 800 peripheral connected .....	103
A.2 Projector with a 800 peripheral connected .....	103
A.2.1 Source numbers 91 — 96 .....	103
A.2.2 Source numbers 81 — 86 .....	104
<b>Glossary .....</b>	<b>105</b>
<b>Index .....</b>	<b>107</b>





# 1. SAFETY INSTRUCTIONS

## Overview

- Safety Instructions

## 1.1 Safety Instructions

### Notice on Safety

This equipment is built in accordance with the requirements of the international safety standards EN60950, UL 1950 and CSA C22.2 No.950, which are the safety standards of information technology equipment including electrical business equipment. These safety standards impose important requirements on the use of safety critical components, materials and isolation, in order to protect the user or operator against risk of electric shock and energy hazard, and having access to live parts. Safety standards also impose limits to the internal and external temperature rises, radiation levels, mechanical stability and strength, enclosure construction and protection against the risk of fire. Simulated single fault condition testing ensures the safety of the equipment to the user even when the equipment's normal operation fails.

### Installation Instructions

Before operating this equipment please read this manual thoroughly, and retain it for future reference. Installation and preliminary adjustments should be performed by qualified BARCO personnel or by authorized BARCO service dealers.

### Owner's Record

The part number and serial number are located at the back side of the projector. Record these numbers in the spaces provided below. Refer to them whenever you call upon your BARCO dealer regarding this product.

Part Number:	
Ser. Number:	
Dealer:	

### Safety Indication on the Product



The lightning flash with an arrowhead within a triangle is intended to tell the user that parts inside this product may cause risk of electrical shock to persons.



The exclamation point within a triangle is intended to tell the user that important operating and/or servicing instructions are included in the technical documentation for this equipment.

Image 1-1  
Safety Indication

### Safety Warning

TO PREVENT FIRE OR ELECTRICAL SHOCK HAZARD, DO NOT EXPOSE THIS EQUIPMENT TO RAIN OR MOISTURE !

### Federal Communication Commission (FCC Statement)

This equipment has been tested and found to comply with the limits of a class A digital device, pursuant to Part 15 of the FCC Rules. These limits are designed to provide reasonable protection against harmful interference when the equipment is operated in a commercial environment. This equipment generates, uses and can radiate radio frequency energy and, if not installed and used in accordance with the instruction manual, may cause harmful interference to radio communications. Operation of this equipment

## 1. Safety Instructions

---

in a residential area is likely to cause harmful interference in which case the user will be required to correct the interference at his own expense.



**The use of shielded cables is required to comply within the limits of Part 15 of FCC rules and EN55022.**

---

- All the safety and operating instructions should be read before using this unit.
- The safety and operating instructions manual should be retained for future reference.
- All warnings on the equipment and in the documentation manuals should be adhered to.
- All instructions for operating and use of this equipment must be followed precisely.

### On Safety

- This product should be operated from an AC power source. Power input is autoranging from 90 V to 230V.
- All equipment in the system is equipped with a 3-wire grounding plug, a plug having a third (grounding) pin. This plug will only fit into a grounding-type power outlet. This is a safety feature. If you are unable to insert the plug into the outlet, contact your electrician to replace your obsolete outlet. Do not defeat the purpose of the grounding-type plug.
- Do not allow anything to rest on the power cord. Do not locate this product where persons will walk on the cord. To disconnect the cord, pull it out by the plug. Never pull the cord itself.
- If an extension cord is used with this product, make sure that the total of the ampere ratings on the products plugged into the extension cord does not exceed the extension cord ampere rating.
- Never push objects of any kind into this product through cabinet slots as they may touch dangerous voltage points or short out parts that could result in a risk of fire or electrical shock.
- Never spill liquid of any kind on the product. Should any liquid or solid object fall into the cabinet, unplug the set and have it checked by qualified service personnel before resuming operations.
- Lightning - For added protection for this video product during a lightning storm, or when it is left unattended and unused for long periods of time, unplug it from the wall outlet. This will prevent damage to the projector due to lightning and AC power-line surges.
- The wires of the main lead are colored in accordance with the following code.

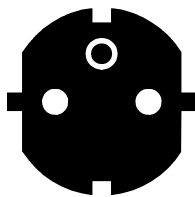

**CEE 7 Plug**  
Green and yellow : Ground  
Blue : Neutral  
Brown : Line

Image 1-2  
Power cord plugs



**ANSI 73.11 Plug**  
Green and yellow : Ground  
White : Neutral  
Black : Line



**This apparatus must be grounded (earthed) via the supplied 3 conductor AC power cable. If the supplied power cable is not the correct one, consult your dealer.**

---

### Caution on Fire Hazard

**DO NOT PLACE FLAMMABLE OR COMBUSTIBLE MATERIALS NEAR THE PROJECTOR !**

BARCO large screen projection products are designed and manufactured to meet the most stringent safety regulations. This projector radiates heat on its external surfaces and from ventilation ducts during normal operation, which is both normal and safe. Exposing flammable or combustible materials to the close proximity of this projector could result in the spontaneous ignition of that material, resulting in a fire. For this reason, it is absolutely necessary to leave an "exclusion zone" around all external surfaces of the projector whereby no flammable or combustible materials are present. The exclusion zone must be not less than 10 cm (4") for Barco Retro Projectors. Do not cover the projector with any material while the projector is in operation. Keep flammable and combustible materials away from the projector at all times. Mount the projector in a well ventilated area away from sources of ignition and out of direct sun light. Never expose the projector to rain or excessive moisture. In the event of fire, use sand, CO<sub>2</sub>, or dry powder fire extinguishers; never use water on an electrical fire. Always have service performed on this projector by authorized BARCO service personnel. Always insist on genuine BARCO replacement parts. Never use non-BARCO replacement parts as they may degrade the safety of this projector.

### On Installation

- Do not place this equipment on an unstable cart, stand, or table. The product may fall, causing serious damage to it.
- Do not use this equipment near water.
- Slots and openings in the cabinet and the back or bottom are provided for ventilation; to ensure reliable operation of the product and to protect it from overheating, these openings must not be blocked or covered. The openings should never be blocked by placing the product on a bed, sofa, rug, or other similar surface. This product should never be placed near or over a radiator or heat register. The projector should not be placed in a built-in installation or enclosure unless proper ventilation is provided.
- Do not block the projector cooling fans or free air movement under and around the projector. Loose papers or other objects may not be nearer to the projector than 4" on any side.

### On Servicing

Do not attempt to service this product yourself, as opening or removing covers may expose you to dangerous voltage potentials and risk of electric shock!

Refer all servicing to qualified service personnel.

Unplug this product from the wall outlet and refer servicing to qualified service personnel under the following conditions:

- When the power cord or plug is damaged or frayed.
- If liquid has been spilled into the equipment.
- If the product has been exposed to rain or water.
- If the product does not operate normally when the operating instructions are followed. Adjust only those controls that are covered by the operating instructions since improper adjustment of the other controls may result in damage and will often require extensive work by a qualified technician to restore the product to normal operation.
- If the product has been dropped or the cabinet has been damaged.
- If the product exhibits a distinct change in performance, indicating a need for service.
- Replacement parts: When replacement parts are required, be sure the service technician has used original BARCO replacement parts or authorized replacement parts which have the same characteristics as the BARCO original part. Unauthorized substitutions may result in degraded performance and reliability, fire, electric shock or other hazards. Unauthorized substitutions may void warranty.
- Safety check: Upon completion of any service or repairs to this projector, ask the service technician to perform safety checks to determine that the product is in proper operating condition.

### On Cleaning

Unplug this product from the wall outlet before cleaning. Do not use liquid cleaners or aerosol cleaners. Use a damp cloth for cleaning. To keep the cabinet looking brand-new, periodically clean it with a soft cloth. Stubborn stains may be removed with a cloth lightly dampened with mild detergent solution. Never use strong solvents, such as thinner or benzine, or abrasive cleaners, since these will damage the cabinet. To ensure the highest optical performance and resolution, the projection lenses are specially treated with an anti-reflective coating, therefore, avoid touching the lens. To remove dust on the lens, use a soft dry cloth. Do not use a damp cloth, detergent solution, or thinner.

### On Repacking

Save the original shipping carton and packing material; they will come in handy if you ever have to ship your equipment. For maximum protection, repack your set as it was originally packed at the factory.

### On Illumination

In order to obtain the best quality for the projected image, it is essential that the ambient light which is allowed to fall on the screen be kept to an absolute minimum. When installing the projector and screen, care must be taken to avoid exposure to ambient light directly on the screen. Avoid adverse illumination on the screen from direct sunlight or fluorescent lighting fixtures. The use of controlled ambient lighting, such as incandescent spot light or a dimmer, is recommended for proper room illumination. Where possible, care should also be taken to ensure that the floors and walls of the room in which the projector is to be installed are non-reflecting, dark surfaces. Brighter surfaces will tend to reflect and diffuse the ambient light and hence reduce the contrast of the projected image on the screen.



## 2. AC POWER

### Overview

- AC Power Cord Connection
- AC Power Voltage
- Switching ON/OFF

### 2.1 AC Power Cord Connection

#### How to connect the AC Power Cord?

Use the supplied power cord to connect your projector to the wall outlet.

1. Plug the female power connector into the male connector at the front side of the electronic block. (image 2-1)

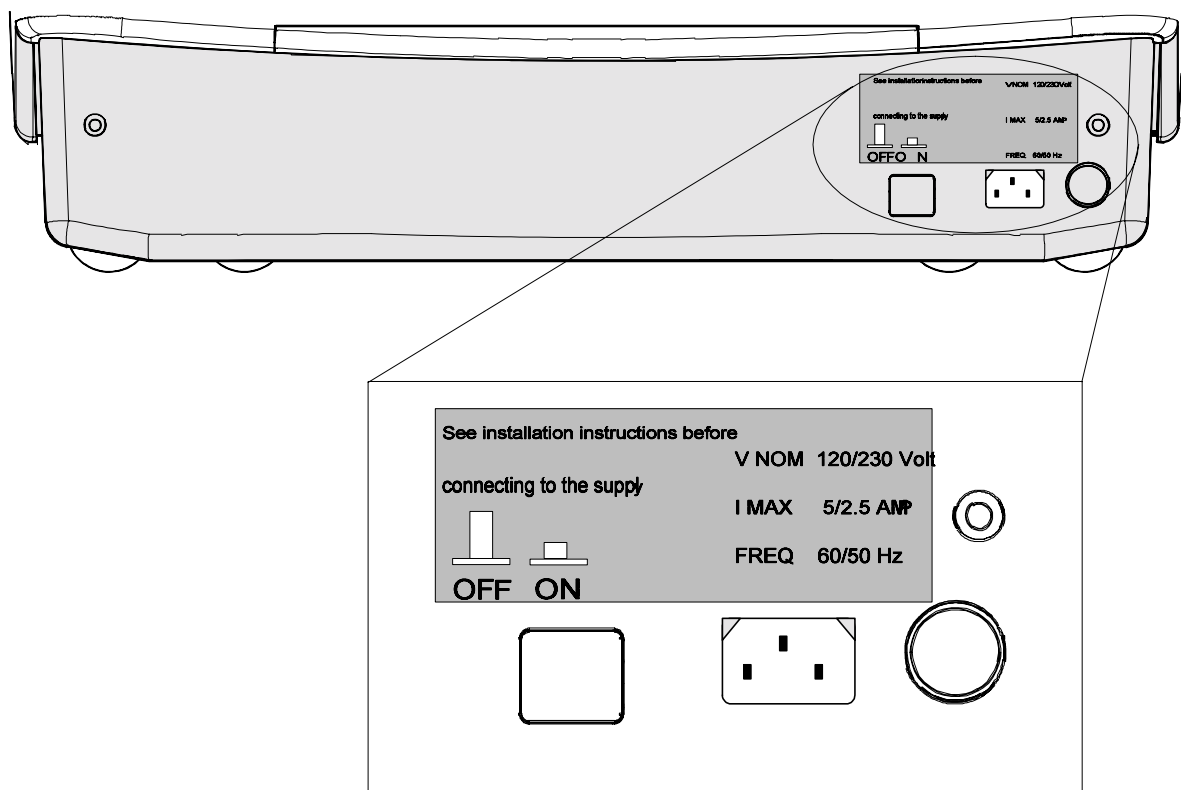

Image 2-1  
Power connection

### 2.2 AC Power Voltage

#### What is the AC Power Voltage?

The power input voltage is autoranging between 100V (-10%) and 240V (+6%).

### 2.3 Switching ON/OFF

#### Switching and led indication

The projector is switched ON and OFF using the power (mains) switch ON/OFF.

- Pressed : ON
- Not pressed : OFF

## 2. AC Power

---

The projector can start now in the 'operational mode' (image displayed) or in the 'stand by mode', depending on the software setup.

Stand by indication lamp :

- no light up : projector in operational mode
- red : projector is in stand by.

Leds on the front plate of the projector

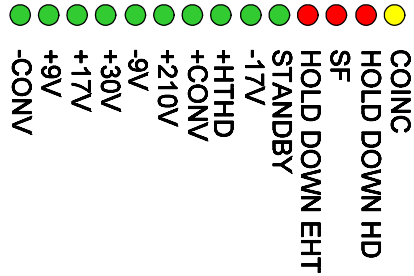

Image 2-2

## 3. SOURCE CONNECTIONS

### Overview

- Input Locations
- Connecting a Composite Video source.
- Connecting a S-Video source.
- Connecting a RGB Analog source with composite sync
- Connecting a RGB Analog source with Tri level composite sync
- Connecting a Component source with composite sync
- Connecting a Component source with Tri level composite sync
- RS232 Connection
- Communication Port for Communication With Peripherals
- 12V Trigger output

### 3.1 Input Locations

#### Input Facilities

- Composite Video
- S-Video
- RGBS or RG<sub>S</sub>B
- RGB3S or RG<sub>3S</sub>B
- (R-Y)Y(B-Y)S or (R-Y)Y<sub>S</sub>(B-Y) [Component Input]
- (R-Y)Y(B-Y)3S or (R-Y)Y<sub>3S</sub>(B-Y) [Component Input]

#### Which source to which input

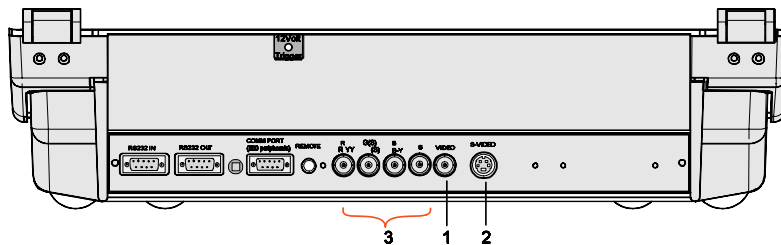

Image 3-1

This table gives an overview of the relation between Input Port #, Source Type and Selection Keys on the RCU:

Input Port #	Source Type	Selection Keys on the RCU
1	Composit Video	1
2	S-Video <sup>1</sup>	2
3	RGBs or RGsB <sup>2</sup>	3
3	RGB with tri level sync <sup>3</sup>	4
3	Component video <sup>4</sup>	5
3	Component video with tri level sync <sup>5</sup>	6

Table 3-1

Input Port #, Source type and Selection Keys on the RCU

1. Input signal Y/C (luma/chroma)  
 2. Input signal : R, G and B with automatic sync detection between separate sync (separate composite sync or with separate hor and vert. sync) or sync on green (composite sync).  
 3. Input signal : R, G and B with separate tri level sync or with tri level sync on green.  
 4. Input signal : R-Y, Y and B-Y with separate sync or with compositesync.  
 5. Input signal : R-Y, Y and B-Y with separate tri level sync or with composite tri level sync.

### 3.2 Connecting a Composite Video source.

#### Which signal to the video input?

Connect Composite video signals from a VCR, OFF air signal decoder, etc..



If a line multiplier is built in, the default position of this line multiplier soft option is ON (active). The video input signal will be displayed as a non interlaced image (= improved image stability). To enable or to disable this function, enter the adjustment mode and change the position of the ON/OFF toggle switch (see chapter 'Random access' adjustment mode).

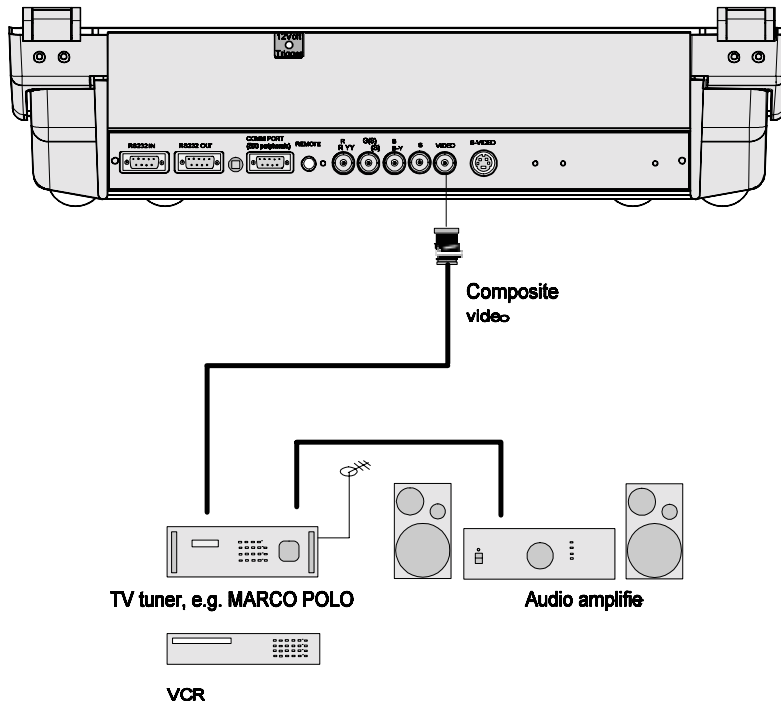

Image 3-2  
Video connection

#### Video input selection via the RCU

1. Press digit button 1

#### Video input selection via the keypad

1. press **ADJUST** key.  
The General access menu is displayed on the screen. (image 3-3)
2. Use the cursor keys to highlight 1.
3. Press **ENTER** to select the highlighted source.

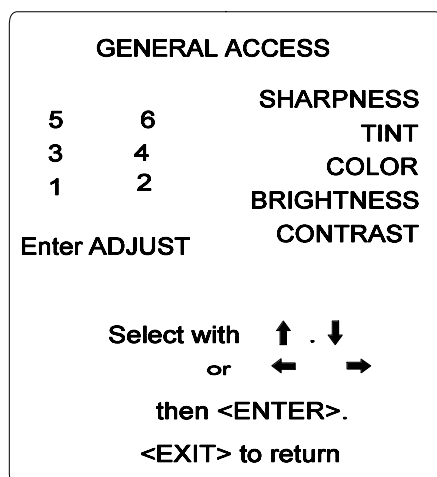

Image 3-3



### 3.3 Connecting a S-Video source.



#### Chrominance

The color component of a video signal that includes information about tint and saturation.



#### Luminance

The component of a video signal that includes information about its brightness.

#### Which signal to the S-video input?

Separate Y-luma/C-chroma signals for higher quality playback of Super VHS signals.



If a line multiplier is built in, the default position of this line multiplier soft option is ON (active). The video input signal will be displayed as a non interlaced image (= improved image stability). To enable or to disable this function, enter the adjustment mode and change the position of the ON/OFF toggle switch (see chapter 'Random access' adjustment mode).

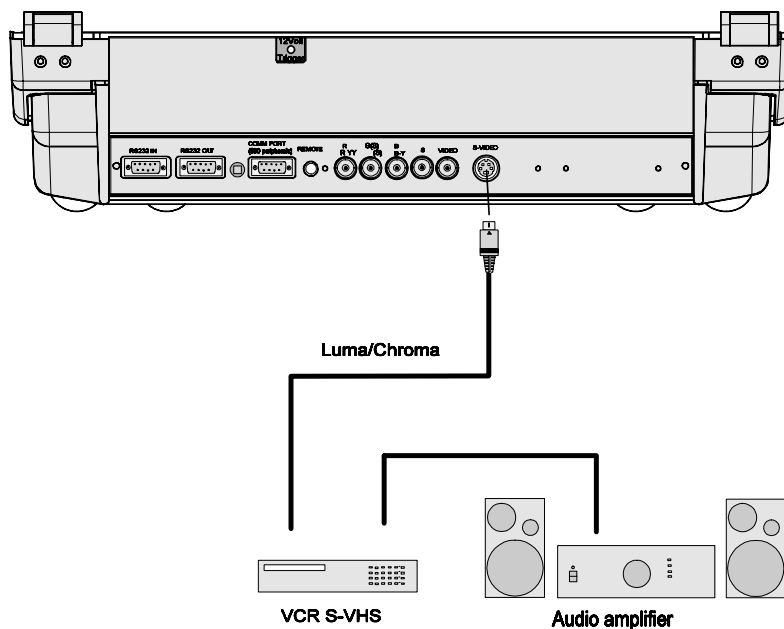

Image 3-4

#### S-Video input selection via the RCU

1. Press digit button 2

#### Video input selection via the keypad

1. press **ADJUST** key.

The General access menu is displayed on the screen. (image 3-5)

2. Use the cursor keys to highlight 2.
3. Press **ENTER** to select the highlighted source.

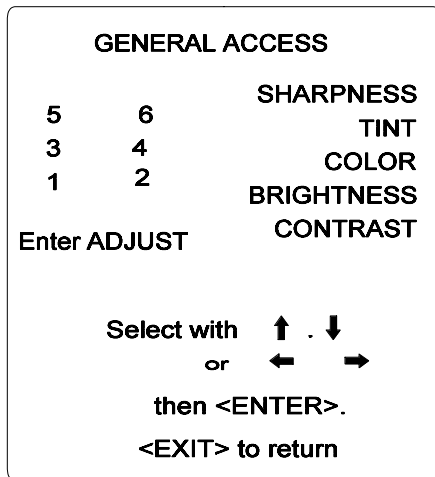
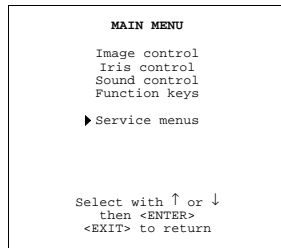

Image 3-5

#### Input priority setting

Depending on the priority setting in the 'Picture Tuning menu', Video or S-Video can be displayed. If the setting is not correct, handle as follow :

1. Press **ADJUST** key to start up the adjustment mode.  
The main menu will be displayed. (menu 3-1)
2. Select *Service Menus*.
3. Press **ENTER** to select.  
A warning menu, *risk of incorrect adjustment*, will be displayed. (menu 3-2)
4. Press **ENTER** to continue if you are qualified, or **EXIT** if not.  
When **ENTER** is pressed, the *Adjustment main menu* will be displayed. (menu 3-3)
5. Select *Random Access*.
6. Press **ENTER** to select.  
The *Choose a setup pattern menu* will be displayed. (menu 3-4)
7. Select *Selected source*.
8. Press **ENTER** to display the *Random Access* menu. (menu 3-5)
9. Select *Picture Tuning*.
10. Press **ENTER** to display the picture tuning menu. (menu 3-6)
11. Select *Port2 : Video*.
12. Press **ENTER** to toggle between VIDEO or S-VIDEO.
13. Press **ADJUST** to return to operational mode.



Menu 3-1

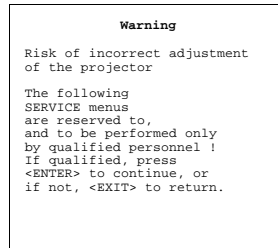

Menu 3-2

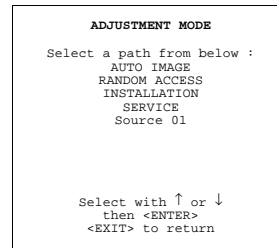

Menu 3-3

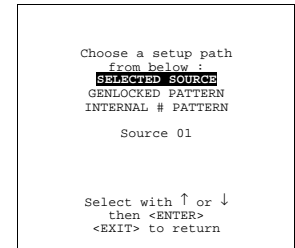

Menu 3-4

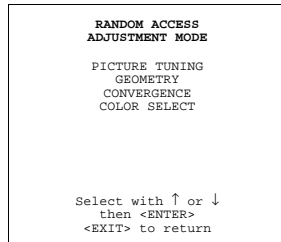

Menu 3-5

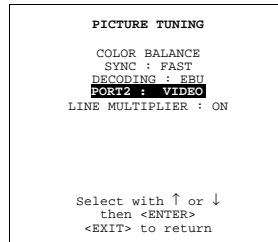

Menu 3-6

### 3.4 Connecting a RGB Analog source with composite sync

#### Which signals can be connected to the input

Connect your RGB source with sync on green, composite or separate sync via an interface to RGBS input. Always use an interface (e.g. Barco Magik Interface R9828120) when a computer and local monitor have to be connected to the projector as the signal cable coming from the computer is limited to 60 cm due to interferences.

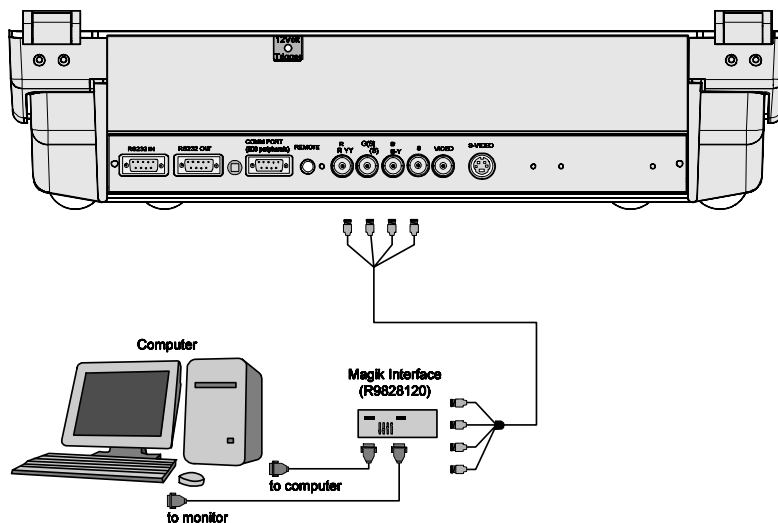

Image 3-6

#### RGBS or RGsB selection via the RCU

1. Press digit button 3.

#### RGBS or RGsB selection via the local keypad

1. Press **ADJUST** key to start up the adjustment mode.  
The General access menu will be displayed. (image 3-7)
2. Use the cursor keys to highlight 3
3. Press **ENTER** to select the highlighted source.

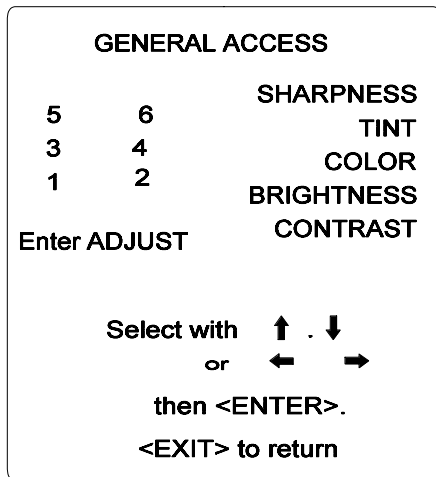

Image 3-7

### 3.5 Connecting a RGB Analog source with Tri level composite sync

#### Which signal can be connected to the input?

RGB analog input terminals with tri level sync input or with tri level sync on green (BNC terminals). The projector detects automatically where the sync signal is located.

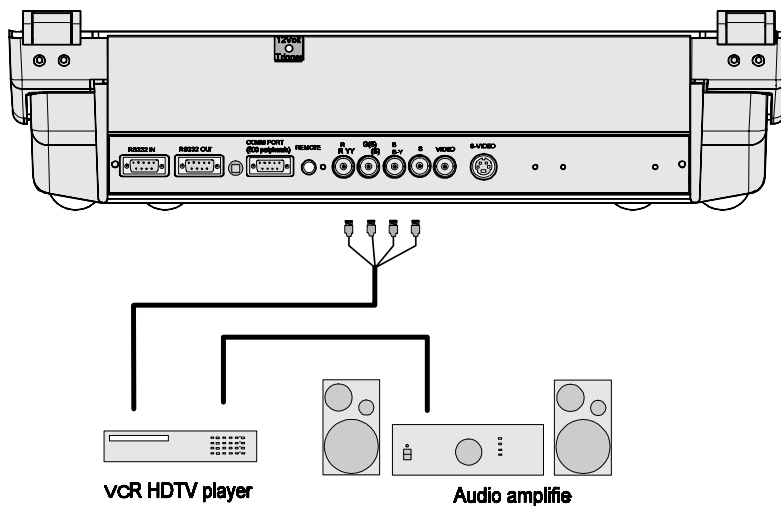

Image 3-8  
RGB3S or RG3sB connection

#### RGB3S or RG3sB selection via the RCU

1. Press digit button 4.

#### RGB3S or RG3sB selection via the local keypad

1. Press **ADJUST** key to start up the adjustment mode.  
The General Access menu will be displayed. (image 3-9)
2. Use the cursor keys to highlight 4
3. Press **ENTER** to select the highlighted source.

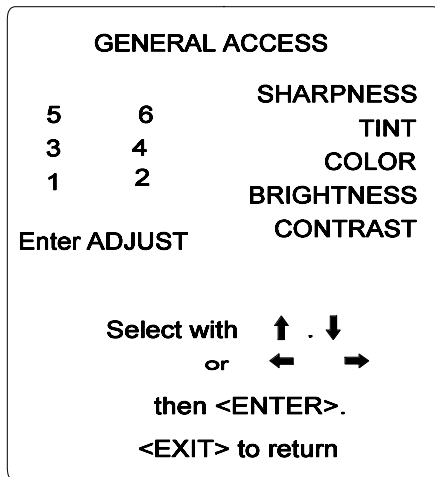

Image 3-9

### 3.6 Connecting a Component source with composite sync

#### Which signal can be connected to the input?

(R-Y)Y(B-Y) analog input terminals with sync input or with sync on green (BNC terminals). The projector detects automatically where the sync signal is located.



Always use an interface (e.g. Barco Magik Interface R9828120) when a computer and local monitor have to be connected to the projector as the signal cable coming from the computer is limited to 60 cm due to interferences.

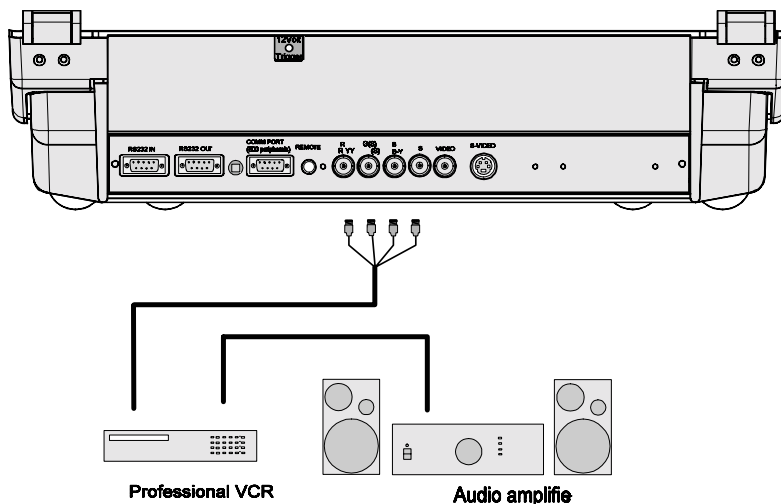

Image 3-10

#### Component input selection via the RCU

1. Press digit button 5.

#### Component input selection via the local keypad

1. Press **ADJUST** key to start up the adjustment mode.  
The General Access menu will be displayed. (image 3-11)
2. Use the cursor keys to highlight 5
3. Press **ENTER** to select the highlighted source.

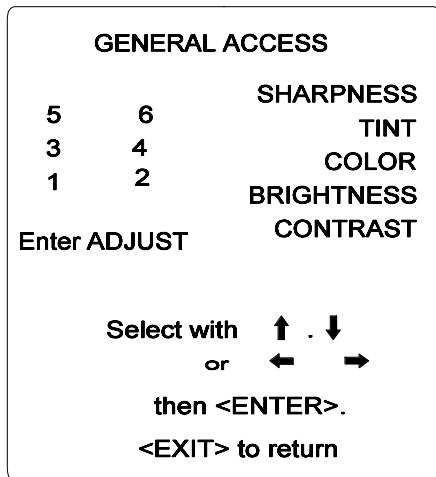

Image 3-11

### 3.7 Connecting a Component source with Tri level composite sync

#### Which signal can be connected to the input?

(R-Y)Y(B-Y) analog input terminals with tri level sync input or with tri level sync on green (BNC terminals). The projector detects automatically where the sync signal is located.

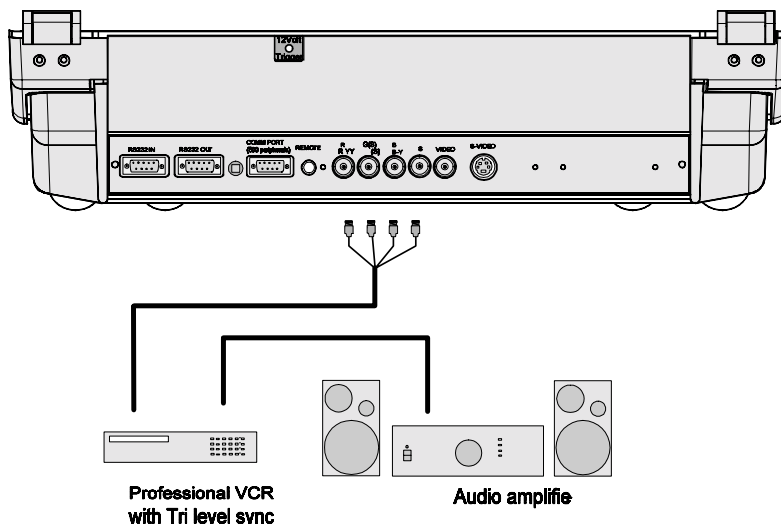

Image 3-12

#### Component input selection via the RCU

1. Press digit button 6.

#### Component input selection via the local keypad

1. Press **ADJUST** key to start up the adjustment mode.  
The General Access menu will be displayed. (image 3-13)
2. Use the cursor keys to highlight 6
3. Press **ENTER** to select the highlighted source.

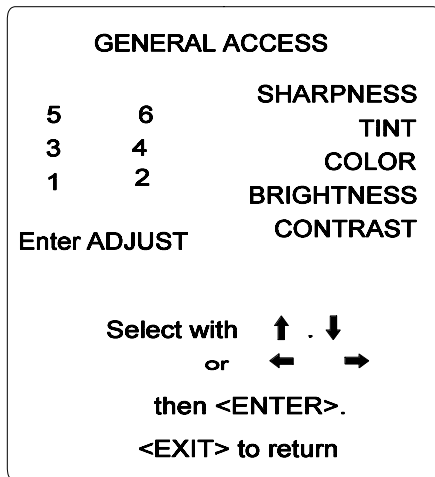

Image 3-13

### 3.8 RS232 Connection



#### RS232

A standard, single-ended (unbalanced) interconnection scheme for serial data communications.

#### RS232 Input and RS232 Output of the projector

The projector is equipped with a RS232 port that allows them to communicate with a computer.

- Easy adjustment of the projector via a computer.
- Allow storage of multiple projector configurations and set ups.
- Wide range of control possibilities.
- Address range from 0 to 255.
- Sending data to the projector or copying the data from the projector to a hard memory device.

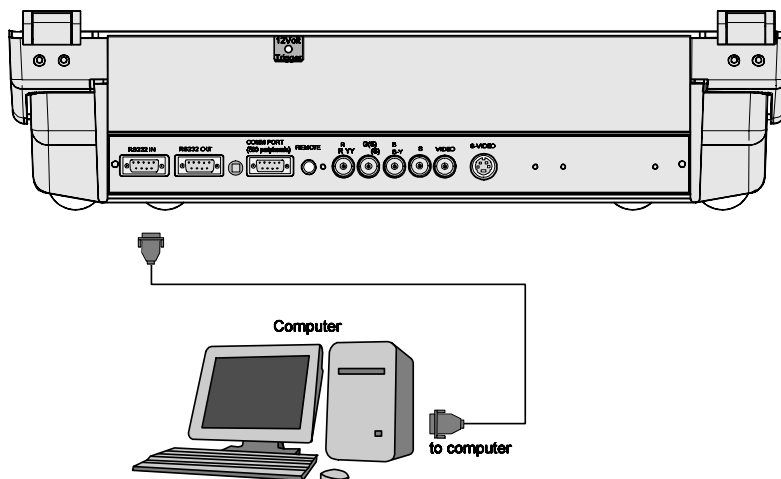

Image 3-14  
RS232 connection

#### How to set up the baud rate for the communication with a computer?

See changing the baud rate in the chapter Service Mode of the Owner's Manual.

### 3.9 Communication Port for Communication With Peripherals

#### Connecting a RCVDS 05 switcher to the projector

- Up to 10 inputs (20 inputs when video and S-video) with the RCVDS 05 switcher (R9827880) and up to 90 inputs when 10 RCVDS switchers are linked via the 5-cable output modules.
- Serial communication with the projector.
- Remote control buttons on the RCVDS to control the projector (source selection and analog settings).
- The selected source number will be displayed on a 2 digit display and the selected input modules will be indicated with a LED on the rear.

#### Connecting a VS05 switcher to the projector

The VS05 can switch up to 5 Composite Video sources, 3 S-Video Sources and 1 RGB analog or component Video source to the projector. In addition, the audio signal proper to the source, can be switched to an audio amplifier. Order number : R9827890.

#### Connecting an IR Remote Receiver to the projector

This infrared receiver unit makes it possible to control the projector from another room. There is a communication line cable between the IR receiver and the projector or the RCVDS. The control information from the RCU can now be sent to the IR Remote Receiver.

The IR Remote Receiver displays the selected source on a 7-segment display.

### 3.10 12V Trigger output

#### What can be done?

12 V output voltage to trigger external equipment such as screen up/down, curtains open/close etc.

This voltage is available when the projector switches from standby to operational mode.

When the projector returns into standby mode, the 12V trigger voltage disappears too.

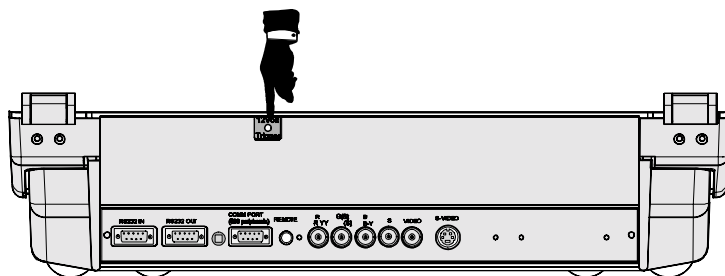

Image 3-15



## 4. GETTING STARTED

### Overview

- Batteries
- RCU & Local keypad
- Terminology overview
- Switching on the projector
- Using the RCU
- Projector Address
- Controlling the projector

### 4.1 Batteries

---

#### Overview

- Battery installation
- Battery replacement

#### 4.1.1 Battery installation

##### How to install the battery

Two batteries are packed together with the RCU. Before using your RCU, install first these batteries.

1. Remove the battery cover on the backside by pushing the handle a little towards the bottom of the RCU.
2. Lift up the top side of the cover at the same time.
3. Insert the batteries as indicated in the RCU.
4. Put the battery cover on its place.

#### 4.1.2 Battery replacement

##### How to replace the batteries in the RCU

To replace the batteries :

1. Remove the battery cover on the backside by pushing the handle a little towards the bottom of the RCU.
2. Lift up the top side of the cover at the same time.
3. Push on the + side of the battery towards the - side
4. Lift up the battery at the same time.
5. Repeat for the second battery.
6. Insert the batteries as indicated in the RCU (battery type AA or LR6 or equivalent).
7. Put the battery cover on its place. (image 4-1)

## 4. Getting Started

---

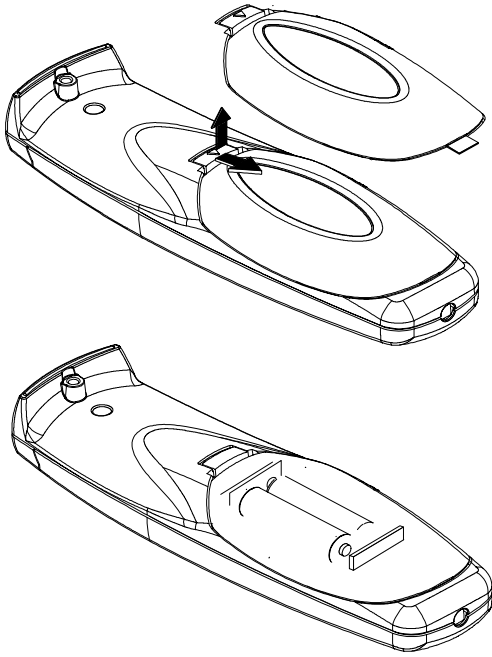

Image 4-1



**Note, only important if more than one projector is installed in the room.**

The common address can be zero (0) or one (1). The standard RCU are setup for common address zero. To change the common address of the RCU, contact a BARCO service center. If it is necessary to program the projector address into the RCU, see chapter 'Getting Started'.

Projector address has to be reprogrammed every time the battery is changed, the RCU will always switch to the default address.

---

## 4.2 RCU & Local keypad

---

### How controlling the projector ?

The projector can be controlled by the local keypad or by the remote control unit.

### Location of the local keypad ?

The local keypad is located on the top side of the projector and is covered by a door on which the projector logo is screened.

To open this door, push as indicated on next drawing and turn it to the front side of the projector.

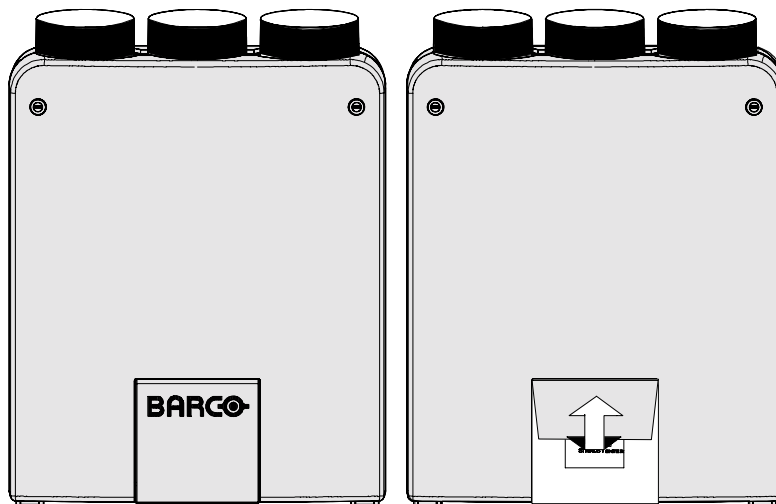

Image 4-2

### Remote control functions.

This remote control includes a battery powered infrared (IR) transmitter that allows the user to control the projector remotely. This remote control is used for source selection, control, adaptation and set up. It includes automatic storing of picture controls (Brightness, Sharpness...) and settings.

Other functions of the remote control are :

- switching between stand by and operational mode.
- switching to "pause" (blanked picture, full power for immediate restarting)
- direct access to all connected sources.

## 4.3 Terminology overview

### Overview

The following table gives an overview of the different functionalities of the keys.

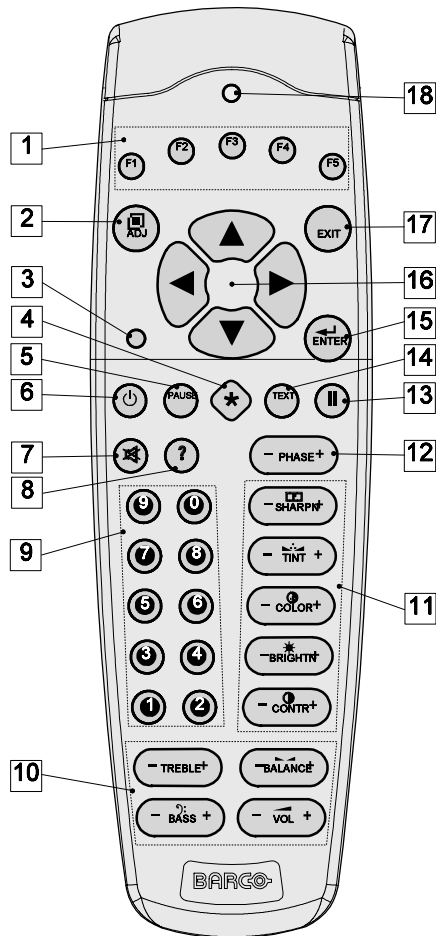

Image 4-3  
RCU function indication

1	Function keys	user programmable keys with functions for direct access.
2	ADJ.	Adjust key, to enter the adjustment mode
3	Address key	(recessed key), to enter the address of the projector (between 0 and 9). Press the recessed address key with a pencil, followed by pressing one digit button between 0 and 9.
4	Selection key (*)	to direct access the zoom/focus/shift functions.
5	PAUSE	to stop projection for a short time, press 'PAUSE'. The image disappears but full power is retained for immediate restarting.

#### 4. Getting Started

6	STBY	standby button, to start projector when the power switch is switched on and to switch off the projector without switching off the power switch.  <b>Attention : Switching to Standby. When the projector is running and you want to go to standby, press the standby key for 2 seconds until the message 'Saving data, please wait' is displayed. Do not press any longer on the standby key otherwise the projector will restart.</b>
7	MUTE	to interrupt the sound reproduction.
8	?	Auto image, to center the image on the active LCD surface.
9	Digit buttons	direct input selection.
10	Audio controls	use these buttons to obtain the desired sound level.
11	Picture controls	press to adjust the projected image.
12	Phase	be sure the projector is warmed up for at least 15 min before adjusting the phase, press to adjust the phase of the projected image.
13	FREEZ	press to freeze the projected image.
14	TEXT	when adjusting one of the image, e.g. controls during a meeting, the displayed bar scale can be removed by pressing 'TEXT' key first. To re-display the bar scale on the screen, press 'TEXT' key again.
15	ENTER	to start up the adjustment mode or to confirm an adjustment or selection in the adjustment mode.
16	Cursor keys	to make menu selections when in the adjustment mode or to zoom/focus when the direct access is active.  Comparison between the cursor keys and the use of the '+' and '-' keys on the local keypad : RCU = local keypad cursor key up = '+' key up cursor key down = '-' key down cursor key right = '+' key right cursor key left = '-' key left
17	EXIT	to leave the adjustment mode or to scroll upwards when in the adjustment mode.
18	RC operation indication	lights up when a button on the remote control is pressed. (This is a visual indicator to check the operation of the remote control)

Table 4-1

## 4.4 Switching on the projector

### How to switch on the projector?

1. Press the mains ON/OFF switch to switch on the projector.

Pressed	ON
Not Pressed	OFF

Table 4-2  
Mains Power Switch

The Stand by indication lamp will show the status of the projector:

No light up	Switched OFF
Green color	Operational mode
Red color	Stand By mode

Table 4-3  
Status lamp

### The switching on modes

When switching on with the power switch, the projector can start in 2 different modes depending on the "Power Up" setting in the Service mode:

- Operational mode (Picture displayed).
- Stand By mode.

### Starting up in Operational Mode

The projector can start up with the selected source or the projector can start up with a warm up cycle message.

<p style="text-align: center;"><b>PROJECTOR WARM UP</b></p> <p>A FULL WHITE PATTERN WILL BE GENERATED FOR x MIN. FOR IMMEDIATE USE OF THE PROJECTOR, PRESS &lt;EXIT&gt; WARNING: SKIPPING THIS PROCEDURE CAN REDUCE THE INITIAL PICTURE QUALITY OF THE PROJECTED IMAGE; YOU CAN ADJUST THE IMAGE DIMENSIONS WITH THE ARROW KEYS TO AVOID SCANNING ON THE EDGES OF THE CRT'S; THIS OPTION CAN BE DISABLED IN THE SERVICE MENU</p> <p style="text-align: center;">with &lt;ENTER&gt; &lt;EXIT&gt; to return</p>
---

Menu 4-1

When this warm up cycle message appears on the screen, the menu offers the possibility to start with a x minutes taking warm up period (press **ENTER**) or to skip this cycle (press **EXIT**). The x minutes and the horizontal frequency can be programmed in the 'Service mode' under the item 'Projector Set Up'.



**This warm up period is built in so that the projector can reach its maximum specifications and minimize all distortions.**

When starting this warm up period, a full white image is shifted on the CRT faceplate to avoid a burn in. Every 30 seconds a text box will be displayed on another place on the screen with the remaining time to go. The image dimensions can be adjusted with the cursor keys to avoid scanning on the edges of the CRT's.

### How to interrupt the warm up period?

1. Press **EXIT** on the RCU.  
The warm up menu will be displayed with the remaining time indication.
2. Press **EXIT** again to quit the warm up cycle and to display the source.

### Starting up in Stand By Mode

The projector starts up in stand by. Press a digit key corresponding to the desired source or press STBY key. The projector displays the selected source or the warm up cycle message. When this warm up message appears on the screen, handle as described in 'Start up in Operational Mode'.

## 4. Getting Started

---



Do not display a stationary image with full brightness and contrast for longer than 20 min., otherwise you risk damage to the CRT's.

---

### How to switch off the projector?

1. Use the same power switch to switch off the projector.

## 4.5 Using the RCU

---

### Pointing to the reflective screen

1. Point the front of the RCU to the screen surface. (image 4-4)

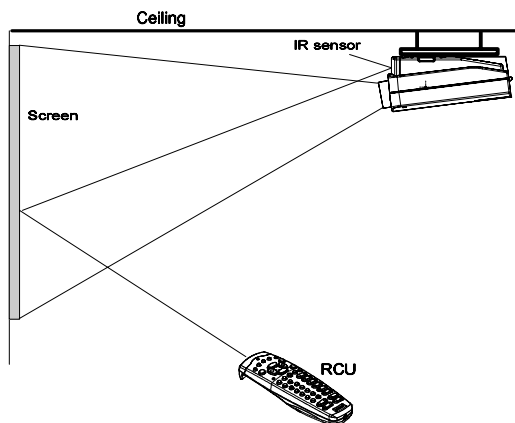

Image 4-4

### Hardwired Remote Input

1. Plug one end of the remote cable in the connector on the bottom of the RCU. (image 4-5)
2. Plug the other end in the connector on the rear panel labelled 'Remote'.

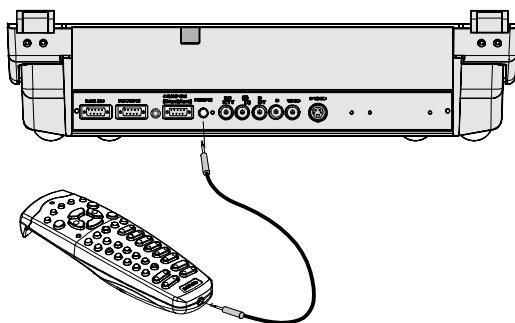

Image 4-5

### Directly to the IR sensors

When using the wireless remote control, make sure you are within the effective operating distance (30m, 100ft in a straight line). The remote control unit will not function properly if strong light strikes the sensor window or if there are obstacles between the remote control unit and the projector's IR sensor.

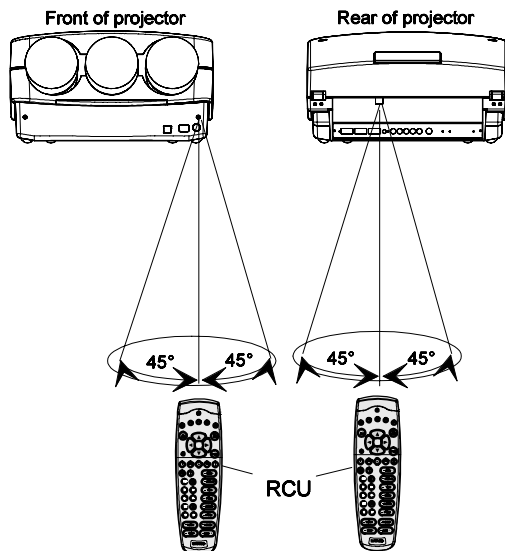

Image 4-6

## 4.6 Projector Address

### 4.6.1 Controlling the projector



#### Projector address

Address installed in the projector to be individually controlled.



#### Common address

Default address. Projector will always execute the command coming from a RCU programmed with that common address.

### Why a projector address ?

As more than one projector can be installed in a room, the separate projector should be separately addressable with an RCU or computer. There for each projector has its own address.

### Set up an individual Projector Address.

The set up of a projector address can be done via the software. See 'Change projector address' in chapter 'Service mode'.

### Projector controlling.

Every projector requires an individual address between 0 and 255 which can be set in the Service mode.

When the address is set, the projector can be controlled now:

- RCU for addresses between 0 and 9.
- computer, e.g. IBM PC (or compatible), Apple MAC, etc. for addresses between 0 and 255.



**A projector will respond to a RCU set to the common address ('0' or '1') regardless of what address is set in the projector itself.**



**The RCU is default programmed with address 0 or 1, 'common address'. With that 'common address' programmed into the RCU, every projector, without exception will listen to the commands given by this RCU. If it is necessary to control a specific projector, than enter the projector address into the RCU (only when that address is between 0 and 9). The projector with the corresponding address will listen to that specific RCU.**

### Common Address

Every projector has a common address '0' or '1'. The choice between '0' and '1' can be selected in the Service mode.

### 4.6.2 Displaying and Programming addresses

#### Displaying the Projector Address on the Screen.

1. Press **Address** key (recessed key on the RCU) with a pencil.

The projector's address will be displayed in a 'Text box'



To continue using the RCU with that specific address, it is necessary to enter the same address with the digit buttons (address between 0 and 9) within 5 seconds after pushing the address key. For example : if the Address key displays projector address 003, then press "3" digit button on the RCU to set the RCU's address to match the projector's address. Do not press 003 digits. This will address the remote control to '0' and control all projectors in the room. If the address is not entered within 5 seconds, the RCU returns to its default address (zero address) and control all projectors in the room.

---

#### How to Program an Address into the RCU?

1. Press the **Address** key (recessed key on the RCU) with a pencil.
2. Enter the address with the digit buttons within 5 seconds after pushing the address key.

**Note:** That address can be any digit between 0 and 9.

## 4.7 Controlling the projector

---

### 4.7.1 Input selection

#### Input Selection via the RCU

1. Key in the corresponding slot number with the digit keys on the RCU.

The selected source will be displayed.

#### Input Selection via the Local Keypad

1. Press the **ADJUST** key to display the General access menu.
2. Highlight the desired source number by pushing the control disc up, down, to the left or the right. Push the control disc up or down to move the cursor up and down, push the control disc to the left or to the right to move the cursor to the left and to the right.
3. Press **ENTER** to confirm your selection.

#### When the source is selected

When a valid and available source is selected, there will be information displayed on the screen about that source. This information includes :

- Source number
- Horizontal frequency
- Vertical frequency

When the entry is a non valid source number, a warning appears on the screen : *input not available*.

When a valid source number is selected, the projector will display this source or it will wait on the selected source number until the source becomes available. A message *source not available* will be displayed for a short time.

### 4.7.2 Picture controls

#### Access via the RCU

The control keys are located on the left side of the key panel of the RCU and indicated with the name of the control and an icon. When an image control is pressed, a text box with bar scale and the function name of the control, e.g. 'brightness...' appears on the screen (only if text is ON). The length of the bar scale indicates the current memorized setting for this source. The bar scale changes as the + or - side of the button of the control are pressed.

#### Access via the local keypad

1. Press the **ADJUST** key to display the General access menu.
2. Use the cursor keys to highlight the desired analog control.
3. Press **ENTER** to select.



### Overview Picture controls

When an image control is pressed, a text box with a bar scale, icon and function name of the control, e.g. 'brightness...' appears on the screen (only if text is ON). See example screen. The length of the bar scale and the value of the numeric indication indicate the current memorized setting for this source. The bar scale changes as the control stick on the RCU is pressed or the + or - buttons on the local keypad.

Brightness	A correct 'brightness' setting is important for good image reproduction. Use the + button for a higher brightness. Use the - button for a lower brightness.
Contrast	A correct 'contrast' setting is important for good image reproduction. Adjust the contrast to the level you prefer, according to room lighting conditions. Use the + button for a higher contrast. Use the - button for lower contrast.
Color	Color saturation is only active for Video and S-Video. Adjust the color intensity of the picture. Use the + button for richer colors. Use the - button for lighter colors.
Tint	Tint is only active for Video and S-Video when using the NTSC 4.43 or NTSC 3.58 system. Use the + button Use the - button.
Sharpness	Use the + button for a sharper picture. Use the - button for a softer picture.
Phase	Use the + or - button to adjust the phase.
Freez	Press Freez to freeze the displayed image.

### Overview Sound Controls

Only when a sound unit is built in.

When a sound control is pressed, a text box with a bar scale, icon and function name of the control, e.g. 'volume...' appears on the screen (only if text is ON). See example screen. The length of the bar scale indicates the current memorized setting for this source. The bar scale changes as the + or - buttons of the control are pressed. The sound controls can only be adjusted with the RCU.

Volume	Volume control adjusts the volume. Use the + button for a higher volume. Use the - button for a lower volume.
Bass	Bass control adjusts the bass level (low tones). Use the + button for more low tones. Use the - button for less low tones.
Treble	Treble control adjusts the treble level (high tones). Use the + button for more high tones. Use the - button for less high tones.
Balance	Is only effective if a external amplifier with loudspeakers is connected to the audio output. The balance control adjust the sound level between the left and the right box. Use the + button for a higher sound level on the right box than on the left one. Use the - button for a higher sound level on the left box than on the right one.

### The Pause Key

When the Pause key is pressed, the image projection is stopped, a blue or black screen will be displayed and the projector remains with full power for immediate restart. The sound is not interrupted. The display on front of the projector will show a "P".

#### 4. Getting Started

---

To restart the image :

- Press **Pause** key.
- Press **EXIT** key
- Select a source number.

#### **The Freeze key (Only with Line Multiplier)**

When the Freeze key is pressed, the image is frozen until this key is pressed again (only with built in Line Multiplier).

## 5. START UP OF THE ADJUSTMENT MODE

### 5.1 How to start up the adjustment mode

#### Start up using the RCU

1. Press the **ADJUST** key.

The projector displays the main menu. (menu 5-1)

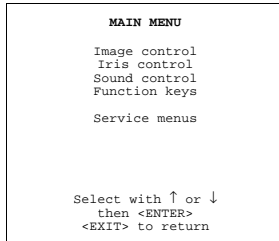

Menu 5-1

#### Start up using the local keypad

1. Press the **ADJUST** key.

The projector displays the General Access menu. (image 5-1)

2. Use the cursor keys to highlight *entern ADJUST*.
3. Press **ENTER**.

The projector displays the main menu (menu 5-1).

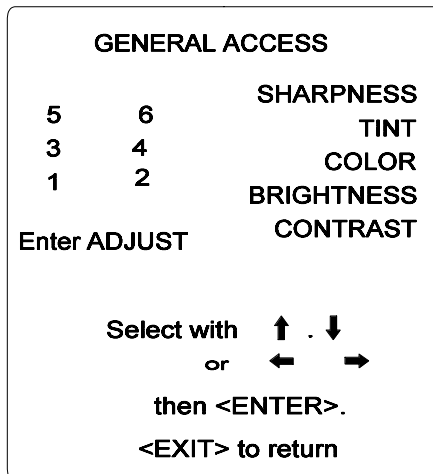

Image 5-1



To adjust the Analog picture controls with the local keypad while in the 'Adjustment mode', press the **ADJUST** key. The next General Access menu will be displayed.

#### Possible paths

Depending on the projector configuration the following paths are possible with the 'Main menu'.

- Image Control - Allows to change the color temperature of the image and to select another format (adjustment) for the image.
- IRIS-Control - This selection will only be available when the autoconvergence unit IRIS is built in into the projector. This control will allow to align the projector automatically.
- Sound Control - Allows to select the sound mode (only when a sound unit is built in).
- Function Keys - Gives an overview of the programmed function for each key.
- Service Menus - Installation and adjustment menus to set up the projector. Before entering a warning will be displayed.

## 5.2 How to adjust an analog control

---

### How to handle

1. Push the cursor keys up or down to select the analog control to be adjusted.
2. Press **ENTER** to confirm.



When the analog control is adjusted the projector returns automatically to the General access menu. When you want to return to the Adjustment mode, press EXIT, otherwise select *quit ADJUST* and press ENTER to return to operational mode.

---

## 6. MAIN MENU

### Overview

- Main Menu Overview
- Image Control
- IRIS Control
- Sound Control
- Function Keys
- Service Menus

### 6.1 Main Menu Overview

---

#### Main Menu Overview

- Image control
  - Line multiplier
  - Color adjust
  - Format select
- Iris control
  - Iris Touch up
  - Iris auto converge
  - Iris full alignment
- Sound control
  - Normal stereo
  - Spacial stereo
  - Pseudo stereo
- Function keys
  - F1
  - F2
  - F3
  - F4
  - F5
- Service menus
  - Iris
  - Guided
  - Random Access
  - Installation
  - Service

### 6.2 Image Control

---

#### Overview

- Starting up the image controls
- Line Multiplier
- Color Adjust, Color temperature set up
- Format Select

### 6.2.1 Starting up the image controls

#### To start up

1. Push the cursor key  $\uparrow$  or  $\downarrow$  to select *Image Control*. (menu 6-1)  
The selected item will change in color and a marker will be displayed in front of it.
2. Press **ENTER** to select.  
The *Image Control* menu will be displayed. (menu 6-2)

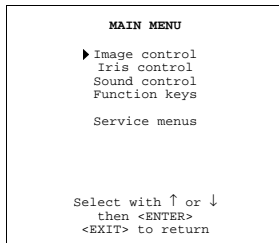

Menu 6-1

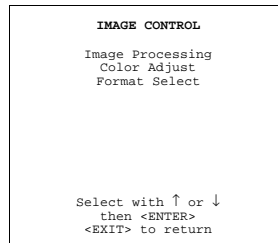

Menu 6-2

### 6.2.2 Line Multiplier

#### Overview

- Changing the Multiplier setting
- Multiplier mode
- Motion Processing On/Off
- Video Equalizing
- Noise Reduction
- Contrast Enhancement

#### 6.2.2.1 Changing the Multiplier setting



**Line multiplying is only possible for Video, S-Video, Component Video images on standard line frequency and RGB signals on 15 kHz.**

**The setting of the line multiplier will be saved together with the source number. Each time this source number is selected, the last saved version will be loaded.**

---

#### Why line multiplying

If a line multiplier is built in and in the ON state, video images can be displayed with different line and frame rates. That will improve the video image quality.

#### How to change the Multiplier setting

1. Push the cursor key  $\uparrow$  or  $\downarrow$  to select *Image Processing*. (menu 6-3)
2. Press **ENTER** to select the *Image Processing* menu.  
The *Image Processing* menu will be displayed. (menu 6-4)

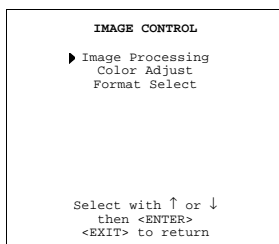

Menu 6-3

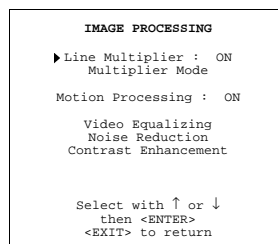

Menu 6-4

## Line Multiplier ON/OFF

1. Push the cursor key  $\uparrow$  or  $\downarrow$  to select *Line Multiplier*. (menu 6-5)
2. Press **ENTER** to toggle between *ON* and *OFF*.

When in the ON state, all multiplier functions are selectable.

```

IMAGE PROCESSING
▶Line Multiplier : ON
  Multiplier Mode
Motion Processing : ON
  Video Equalizing
  Noise Reduction
  Contrast Enhancement

Select with  $\uparrow$  or  $\downarrow$ 
then <ENTER>
<EXIT> to return

```

Menu 6-5

### 6.2.2.2 Multiplier mode

#### What can be selected?

The multiplier menu makes it possible to select different scan rate for the connected video signal.



#### Interlaced

Short for interlaced scanning. Also called line interlace. A system of video scanning whereby the odd- and even-numbered lines of a picture are transmitted consecutively as two separate interleaved fields. Interlace is a form of compression.



#### Progressive

Short for progressive scanning. A system of video scanning whereby lines of a picture are transmitted consecutively, such as in the computer world

#### Start up the Multiplier mode

1. Push the cursor key  $\uparrow$  or  $\downarrow$  to select *Multiplier mode*. (menu 6-6)
2. Press **ENTER** to select.

One of the different Multiplier mode menus will be displayed. (menu 6-7)

```

IMAGE PROCESSING
Line Multiplier : ON
▶Multiplier Mode
Motion Processing : ON
  Video Equalizing
  Noise Reduction
  Contrast Enhancement

Select with  $\uparrow$  or  $\downarrow$ 
then <ENTER>
<EXIT> to return

```

Menu 6-6

```

MULTIPLIER MODE
▶50Hz 625 lines P
 50Hz 935 lines P
100Hz 625 lines P
 50Hz 1250 lines P
100Hz 1250 lines I

Select with  $\uparrow$  or  $\downarrow$ 
then <ENTER>
<EXIT> to return

```

Menu 6-7

```

MULTIPLIER MODE
▶60Hz 525 lines P
 60Hz 785 lines P
120Hz 525 lines P
 60Hz 1050 lines P
120Hz 1050 lines I

Select with  $\uparrow$  or  $\downarrow$ 
then <ENTER>
<EXIT> to return

```

Menu 6-8

## 6. Main Menu

### Changing the scan rate

1. Push the cursor key ↑ or ↓ to select a new scan rate. (menu 6-9)
2. Press **ENTER** to activate this scan rate.

50Hz	Vertical frequency of the image
1250 Lines	Quantity of horizontal lines
P = Non Interlaced = Progressive Scan I = Interlaced	Interlace mode

```
MULTIPLIER MODE
50Hz  625 lines  P
50Hz  935 lines  P
▶ 100Hz 625 lines  P
50Hz  1250 lines P
100Hz 1250 lines I

Select with ↑ or ↓
then <ENTER>
<EXIT> to return
```

Menu 6-9

### 6.2.2.3 Motion Processing On/Off

#### What can be done?

With this function it is possible to recognize whether the source material was originally film or video. That prevents the creation of motion artifacts.

#### How to toggle Motion Processing On/Off?

1. Push the cursor key ↑ or ↓ to select *Motion Processing*. (menu 6-10)
2. Press **ENTER** to toggle *Motion Processing* On/Off.

```
IMAGE PROCESSING
Line Multiplier : ON
Multiplier Mode
▶ Motion Processing : ON
Video Equalizing
Noise Reduction
Contrast Enhancement

Select with ↑ or ↓
then <ENTER>
<EXIT> to return
```

Menu 6-10

### 6.2.2.4 Video Equalizing

#### What can be done?

The sharpness of the image can be adjusted for 3 frequency bands (low, medium and high) separately. In addition to the 7 pre-programmed factory presets a customized adjustment of the sharpness for 3 ranges is also possible.



## How to adjust Video Equalizing?

1. Push the cursor key  $\uparrow$  or  $\downarrow$  to select *Video Equalizing* and press **ENTER** to select. (menu 6-11)  
The *Video Equalizing* menu will be displayed. (image 6-1)
2. Push the  $\leftarrow$  or  $\rightarrow$  keys to select the desired frequency band (Low, Mid or High) or the Factory Preset : x.
3. Push the cursor key  $\uparrow$  or  $\downarrow$  to adjust the sharpness in the chosen frequency band (Low, Mid or High) or to scroll through the factory presets (x = 1 to 7).  
**Note:** *Factory preset 8 is equal to the custom adjustment as made with low, mid and high.*
4. Press **EXIT** to return to the *Image Processing* menu.

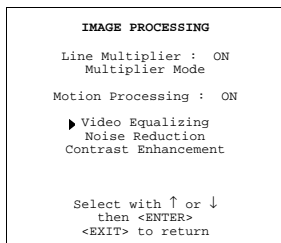

Menu 6-11

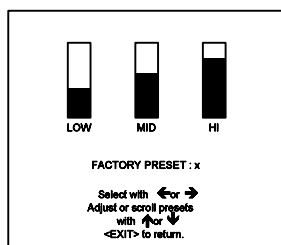
Image 6-1  
Video Equalizing menu

### 6.2.2.5 Noise Reduction

#### What can be done?

Noisy, lower quality video images can be ameliorated by use of the Noise Reduction feature.

#### How to adjust Noise Reduction?

1. Push the cursor key  $\uparrow$  or  $\downarrow$  to select *Noise Reduction* and press **ENTER** to select. (menu 6-12)  
The Dynamic Noise Reduction bar scale will be displayed. (image 6-2)
2. Push the cursor key  $\uparrow$  or  $\downarrow$  to adjust the Noise Reduction.
3. Press **EXIT** to return to the *Image Processing* menu.

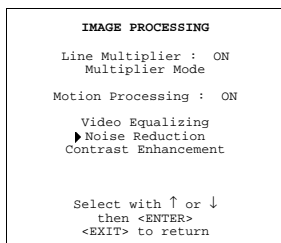

Menu 6-12

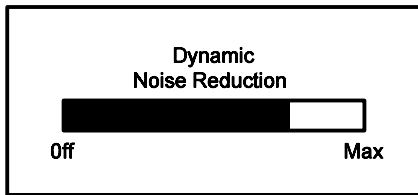

Image 6-2  
Dynamic Noise Reduction bar scale

### 6.2.2.6 Contrast Enhancement

#### What can be done?

Enhancing the contrast results in a more dynamic image.

#### How to adjust the Contrast Enhancement?

1. Push the cursor key  $\uparrow$  or  $\downarrow$  to select *Contrast Enhancement* and press **ENTER** to select. (menu 6-13)  
The Contrast Enhancement bar scale will be displayed. (image 6-3)
2. Push the cursor key  $\uparrow$  or  $\downarrow$  to adjust the Contrast Enhancement.
3. Press **EXIT** to return to the *Image Processing* menu.

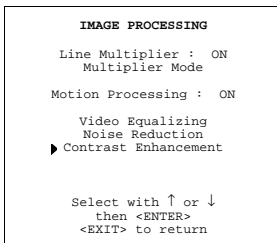

Menu 6-13

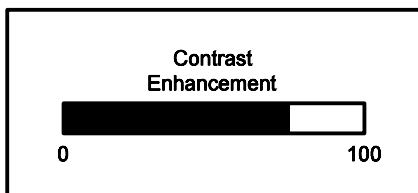

Image 6-3  
Contrast Enhancement bar scale

### 6.2.3 Color Adjust, Color temperature set up

#### What can be done?

The color temperature of the image can be installed. The customer has the choice between 4 factory preset color temperatures and one custom. This custom color temperature has to be adjusted in the *Random Access Adjustment Mode*.

## How to change the color temperature

1. Push the cursor key  $\uparrow$  or  $\downarrow$  to select *Color Adjust*. (menu 6-14)
2. Press **ENTER** to display the *Color Adjust* menu. (menu 6-15)
3. Push the cursor key  $\uparrow$  or  $\downarrow$  to select the desired color temperature.
4. Press **ENTER** to activate that color temperature.

```

IMAGE CONTROL
Image Processing
  Color Adjust
  Format Select

Select with  $\uparrow$  or  $\downarrow$ 
then <ENTER>
<EXIT> to return

```

Menu 6-14

```

COLOR ADJUST
Broadcast 3200 Ck
Film 4900 Ck
Video 6500 Ck
Computer 9300 Ck
Custom

Select with  $\uparrow$  or  $\downarrow$ 
then <ENTER>
<EXIT> to return

```

Menu 6-15

## 6.2.4 Format Select

### Overview

- Selecting a Format
- Adding a name to a Format
- Storing the settings to a new Format.

### 6.2.4.1 Selecting a Format

#### What can be done

For one source, up to 8 different sets of settings can be stored. A set of settings is called 'Format'. A 'Format' can be 'available' or 'free'. 'Available' when settings are stored in this location. 'Free' when no settings are stored in this location. This location can be used for storing new adjustment settings for this source. When 'available', a name of 8 characters can be programmed by the user.

#### How selecting a Format.

1. Push the cursor key  $\uparrow$  or  $\downarrow$  to select *Format*. (menu 6-16)
2. Press **ENTER** to display the *Format List*. (menu 6-17)
3. Press **ENTER** to select.

```

IMAGE CONTROL
Image Processing
  Color Adjust
  Format Select

Select with  $\uparrow$  or  $\downarrow$ 
then <ENTER>
<EXIT> to return

```

Menu 6-16

```

FORMAT LIST
Source 01 Video
Format 1 Available xxxxxx
Format 2 Free xxxxxx
Format 3 Available xxxxxx
Format 4 Free xxxxxx
Format 5 Free xxxxxx
Format 6 Free xxxxxx
Format 7 Free xxxxxx
Format 8 Free xxxxxx

Select with  $\uparrow$  or  $\downarrow$ 
then <ENTER>
<EXIT> to return
<TEXT> to enter a name

```

Menu 6-17

### 6.2.4.2 Adding a name to a Format

#### What can be done?

A name can be added to an available format.

## 6. Main Menu

### How to add a name?

1. Push the cursor key  $\uparrow$  or  $\downarrow$  to select the Format to which a name has to be added. (menu 6-18)
2. Press **TEXT** to display the compose menu. (menu 6-19)
3. The position of the character which will be edited, will be indicated with a digit. Push the cursor keys  $\uparrow$ ,  $\downarrow$ ,  $\leftarrow$  or  $\rightarrow$  to select the first character.
4. Press **ENTER** to select the chosen character.

This character will be inserted on the indicated position. The *edit character* indication will be incremented with one.

5. Continue in the same way for the other characters.
6. When the name is completed, press **EXIT** to return to the 'Format List' menu. (menu 6-20)

```
FORMAT LIST
Source 01 Video
Format 1 Available xxxxxx
Format 2 Free xxxxxx
Format 3 Available xxxxxx
Format 4 Free xxxxxx
Format 5 Free xxxxxx
Format 6 Free xxxxxx
Format 7 Free xxxxxx
Format 8 Free xxxxxx

Select with  $\uparrow$  or  $\downarrow$ 
then <ENTER>
<EXIT> to return
<TEXT> to enter a name
```

Menu 6-18

```
COMPOSE
A B C D E F G H I
J K L M N O P Q R
S T U V W X Y Z
\ : -
0 1 2 3 4 5 6 7 8 9
xxxxxxx
Edit character 1

Select with  $\uparrow$  or  $\downarrow$ 
then <ENTER>
<EXIT> to return
```

Menu 6-19

```
FORMAT LIST
Source 01 Video
Format 1 Available xxxxxx
Format 2 Free xxxxxx
Format 3 Available BARCO
Format 4 Free xxxxxx
Format 5 Free xxxxxx
Format 6 Free xxxxxx
Format 7 Free xxxxxx
Format 8 Free xxxxxx

Select with  $\uparrow$  or  $\downarrow$ 
then <ENTER>
<EXIT> to return
<TEXT> to enter a name
```

Menu 6-20

### 6.2.4.3 Storing the settings to a new Format.

#### How to store

1. Push the cursor key  $\uparrow$  or  $\downarrow$  to select a free format. (menu 6-21)
2. Press **ENTER** to activate.
3. Make any adjustment to the image.
4. Quit the adjustment mode by pressing **ADJUST**.

The selected format will change from free to available.

```
FORMAT LIST
Source 01 Video
Format 1 Available xxxxxx
Format 2 Free xxxxxx
Format 3 Available xxxxxx
Format 4 Free xxxxxx
Format 5 Free xxxxxx
Format 6 Free xxxxxx
Format 7 Free xxxxxx
Format 8 Free xxxxxx

Select with  $\uparrow$  or  $\downarrow$ 
then <ENTER>
<EXIT> to return
<TEXT> to enter a name
```

Menu 6-21

## 6.3 IRIS Control

### Overview

- Starting up the IRIS Controls
- IRIS Touch Up
- IRIS Auto Converge
- IRIS Full Alignment

### What is possible?

With the IRIS functions it is possible to ameliorate the convergence and alignment of the image.

### 6.3.1 Starting up the IRIS Controls



Before starting one of the IRIS functions, be sure the projector has warmed up for at least 20 min. Only after 20 min the projector has reached its full specifications.

#### How to start up

1. Push the cursor key ↑ or ↓ to select *IRIS control*. (menu 6-22)
2. Press **ENTER** to select.

The *IRIS control* menu will be displayed. (menu 6-23)

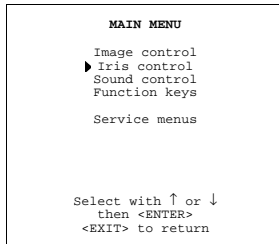

Menu 6-22

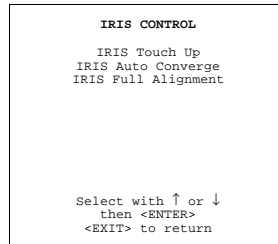

Menu 6-23

### 6.3.2 IRIS Touch Up

#### What can be done?

If you discover in the middle of the image a convergence misalignment between red, green and blue, the static convergence of this currently selected source can be adjusted with the touch up function.

#### Start up the IRIS touch up

1. Push the cursor key ↑ or ↓ to select *IRIS Touch Up*. (menu 6-24)
2. Press **ENTER** to activate the touch up function.

The process starts and when successfully completed, the projector will return to image display of the current source.

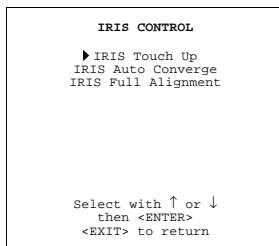

Menu 6-24

### 6.3.3 IRIS Auto Converge

#### What can be done?

The autoconvergence on the current source will be carried out automatically, starting from the existing settings. By projecting alternately red and blue lines, 25 convergence areas are aligned onto the green pattern.

### Starting the IRIS Auto Converge

1. Push the cursor key ↑ or ↓ to select *IRIS Auto Converge*. (menu 6-25)
2. Press **ENTER** to activate the autoconvergence function.

The process starts and when successfully completed, the projector will return to image display of the current source.

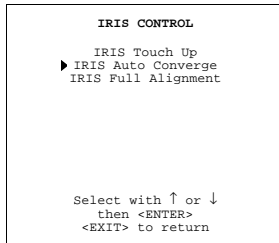

Menu 6-25

### 6.3.4 IRIS Full Alignment

#### What can be done?

The IRIS full alignment function adjust the geometry of the image (coarse geometry alignment).

This procedure takes about 45 seconds.

#### Starting up the IRIS Full Alignment

1. Push the cursor key ↑ or ↓ to select *IRIS Full Alignment*. (menu 6-26)
2. Press **ENTER** to activate the auto alignment function.

The process starts and when successfully completed, the projector will return to the IRIS control menu.

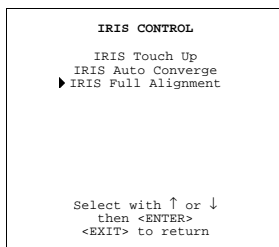

Menu 6-26

## 6.4 Sound Control

---

#### What can be done?

When the sound option is available, the following sound modes can be selected : normal stereo, spatial stereo, pseudo stereo or mono.

### Selecting the sound control.

1. Push the cursor key ↑ or ↓ to select *Sound Control*. (menu 6-27)
2. Press **ENTER** to select the Sound Control function.

The Sound Control menu will be displayed. (menu 6-28)

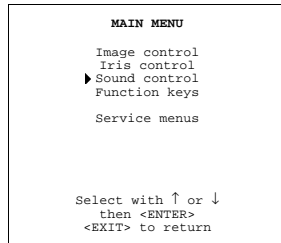

Menu 6-27

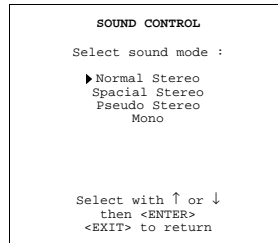

Menu 6-28

## 6.5 Function Keys

### What can be done?

Quick access keys to customer pre-programmed adjustments. Almost any adjustment can be added to a function key. To program a function key, it is necessary to enter into the 'Service Menu'. To activate a function key, just press the corresponding key.

The following functions are factory pre-programmed :

- F1 = IRIS Touch up
- F2 = Convergence Red on Green
- F3 = Convergence Blue on Green
- F4 = H & V Size
- F5 = Color Balance

### To get an overview of the programmed keys

1. Push the cursor key ↑ or ↓ to select *Function Keys*. (menu 6-29)
2. Press **ENTER** to display an overview of the function keys. (menu 6-30)

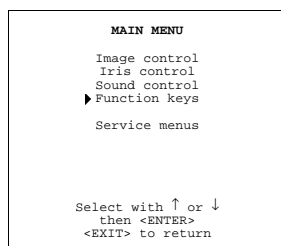

Menu 6-29

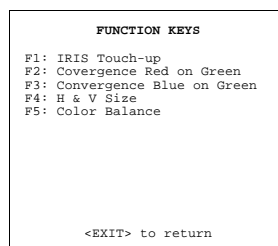

Menu 6-30

## 6.6 Service Menus

### What can be done?

With the complete set of Service menus such as IRIS, Guided, Random Access, Installation and Service it is possible to adjust the projector completely.

When entering the Service Menus, a warning will be displayed mentioning that only qualified service personnel may enter the Service menus.

### How to enter the Service Menus

1. Push the cursor key ↑ or ↓ to select *Service Menus*. (menu 6-31)

A warning will be displayed. (menu 6-32)

"Risk of incorrect adjustment of the projector. The following SERVICE menus are reserved to and to be performed only by qualified personnel ! If qualified, press **ENTER** to continue, or if not, **EXIT** to return.

2. If qualified, press **ENTER**. (menu 6-33)

If not qualified, press **EXIT**.

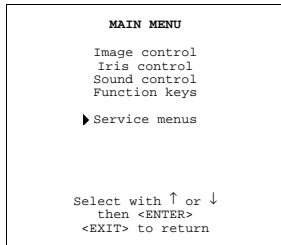

Menu 6-31

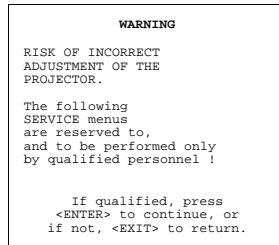

Menu 6-32

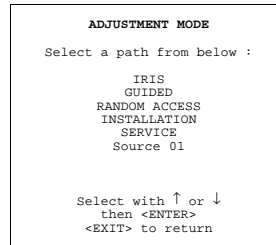

Menu 6-33



## 7. ENTERING THE SERVICE MENUS

### Overview

- The Adjustment menus
- Password Protection

### 7.1 The Adjustment menus

#### What is available in the Adjustment menus

A complete set of adjustments divided in different modes are available to adjust the projector, these different modes are:

IRIS	To autoalign and autoconverge the projector.
Guided	Guided should be selected if the user intends to perform a complete alignment of the projected image. All the necessary geometry and convergence adjustments are executed in a predetermined sequence.
Random Access	Should only be accessed if the user is highly qualified and knows the sequence of adjustments. Has to be used to adjust the image.
Installation	Should only be selected if the projector is relocated and/or a different screen size is desired. When selecting Installation the user or operator will be warned to call a qualified technician to perform the installation procedure.
Service	Should only be selected if the user intends to change the predefined settings.

#### How to enter the Adjustment menus with the RCU?

1. Press the **ADJUST** key.  
The *Main menu* will be displayed. (menu 7-1)
2. Push the cursor key  $\uparrow$  or  $\downarrow$  to select *Service menus*.
3. Press **ENTER** to select.  
A warning will be displayed. (menu 7-2)
4. If qualified, press **ENTER** to continue.  
The Service main menu will be displayed. (menu 7-3)

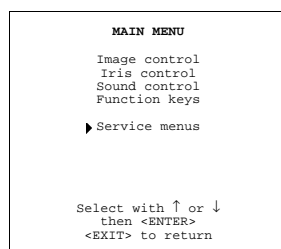

Menu 7-1

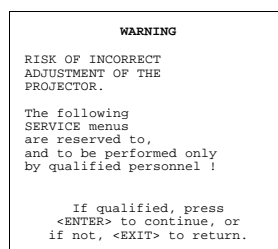

Menu 7-2

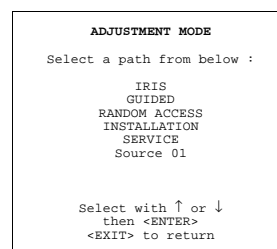

Menu 7-3

#### How to enter the Adjustment menus with the local keypad?

1. Press the **ADJUST** key.  
The projector displays the *General Access Menu*. (image 7-1)
2. Use the cursor keys to highlight *enter ADJUST*.
3. Press **ENTER** to select.  
The *Main menu* will be displayed (menu 7-1).
4. Continue as described in *How to enter the Adjustment menus with the RCU*.

## 7. Entering the service menus

---

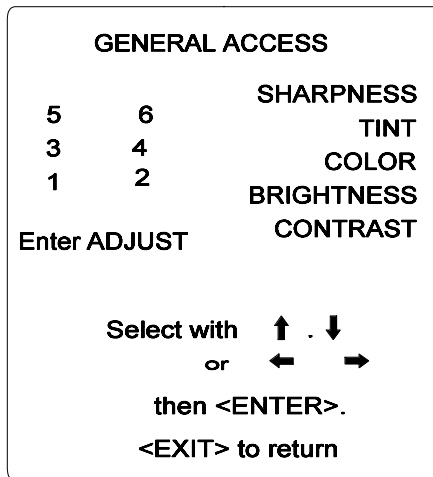

Image 7-1

## 7.2 Password Protection

---

### Password Protection

Some items in the Service menus are password protected. While selecting such an item, the projector asks to enter your password.



**Password Protection is only available when the password strap on the controller module is on. Contact a Barco authorized technician when no password is requested during the adjustment procedure and Password Protection is desired.**

---

### Entering the Password via the RCU

The Password contains 4 digits, when the projector asks to enter your password:

1. Enter the digits with the numeric keys on the RCU (e.g.: 2319).

For each digit entered, a 'X' appears on the screen under the displayed text 'enter password' (menu 7-4)

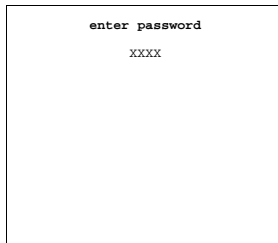

Menu 7-4



**When the password is correctly entered, all other password protected items are accessible without reentering the password. When reentering the adjustment mode, it will be necessary to enter your password again when selecting a password protected item.**

**When the password is wrong, the error message "Wrong Password !!!" will be displayed.**

---

### Entering the Password via the local keypad

When the compose password menu is displayed:

1. Select with the cursor the first digit of your password. (menu 7-5)
2. Press **ENTER** to select.
3. Select the next digit of your password.
4. Press **ENTER** to select.
5. Handle in the same way for the third and fourth digit.

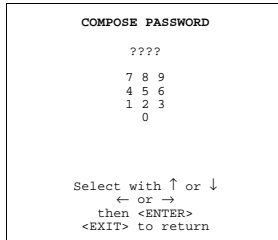

Menu 7-5



**When the password is correctly entered, all other password protected items are accessible without reentering the password. When reentering the adjustment mode, it will be necessary to enter your password again when selecting a password protected item.**

**When the password is wrong, the error message "Wrong Password !!!" will be displayed.**

---



---

## 8. RANDOM ACCESS ADJUSTMENT MODE

### Overview

- Introduction
- Random Access Overview
- Selecting Setup Pattern
- Random Access mode selection menu
- Picture Tuning
- Geometry Adjustments
- Convergence Adjustment

### 8.1 Introduction

---

#### How to start up Random Access Adjustment Mode?

1. Press the **ADJUST** key to start up the Adjustment Mode.

The main *Adjustment Mode* menu will be displayed.

2. Push the cursor key  $\uparrow$  or  $\downarrow$  to highlight *Random Access* and press **ENTER** to select. (menu 8-1)

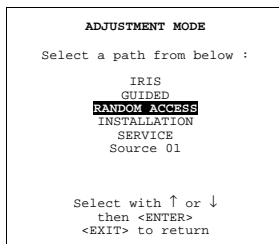

Menu 8-1



**Some items in the Random access mode are password protected (when the password function is enabled). Enter your password to continue. All other password protected items are now also available if you stay in the adjustment mode.**

---

## 8.2 Random Access Overview

---

### Random Access Overview

- Picture Tuning
  - Color Balance
  - Decoding
  - Sync
  - Peaking
    - Off
    - Low Source Frequency
    - Mid Source Frequency
    - High Source Frequency
  - Clamp Mode
  - Port 2
  - Line Multiplier (Optional)
    - Motion Processing
    - Output Mode
    - Video Equalizing
    - Noise Reduction
    - Contrast Enhancement
    - Split Screen
    - Advanced Settings
      - Time Base Correction
      - Luminance Decay
      - V Sync Ref
      - Clamp Gating
      - Limo + Options
        - Coring
        - LTI
        - CTI
      - Factory Preset
- Geometry
  - H-Phase
  - Raster Shift
    - Coarse Green
    - Coarse Red Horizontal
    - Coarse Blue Horizontal
    - Fine Green
    - Fine Blue
  - Left / Right
    - Vertical Centerline Bow
    - Vertical Centerline Skew
    - Side Bow
    - Side Keystone
    - Seagull Correction
  - Top / Bottom
    - Horizontal Centerline Bow
    - Horizontal Centerline Skew
    - Top Keystone
    - Top Bow
    - Bottom Keystone
    - Bottom Bow
    - Seagull Correction
  - Size
  - Vertical Linearity
  - Blanking
- Convergence
- Color Select

## 8.3 Selecting Setup Pattern

### How to select the Setup Pattern?

If an external source is connected to the projector, the following screen will be displayed. To select the desired setup pattern, handle as follow:

1. An external source is connected to the projector.  
Push the  $\uparrow$  or  $\downarrow$  keys to highlight the desired setup pattern and press **ENTER** to select. (menu 8-2)

Selected Source	External source
Genlocked Pattern	Internally generated pattern, locked on the external source, the pattern changes with the adjustment selection.
Internal # Pattern	Internally generated pattern, locked on internal generated sync signals. (No external source necessary)

If no, The internal pattern menu will be displayed.

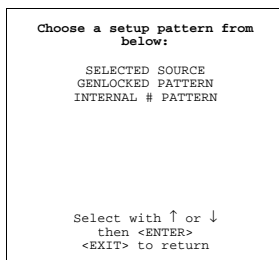

Menu 8-2

### When using the Internal # Pattern?

The Internal # Pattern menu will be displayed if the Internal Cross Hatch Pattern has been selected or if no source is connected to the projector.

### Available Factory Preset Frequencies

The table below lists the 16 fixed factory preset frequencies available. Another 8 blocks are custom programmable.

15.6/50	PAL/SECAM
15.7/60	NTSC
31.2/50	EDTV
31.5/60	IDTV
31.2/50	HDTV EUREKA
31.5/60	HDTV ATV
33.7/60	HDTV HISION
15.8/60	EGA1
21.8/60	EGA2
31.5/60	VGA3
31.5/60	XGA 1.2
35.5/87	VGA 4
44.2/70	Super VGA 2
48.5/60	Super VGA 1
61.0/76	Super VGA 3

## 8. Random Access Adjustment Mode

72.1/67	Super VGA 4
63.9/76	APOLLO

### How to select the desired Cross Hatch Frequency?

To select a desired cross hatch frequency, handle as follow:

1. Push the cursor key ↑ or ↓ to highlight the desired Cross Hatch Frequency. (menu 8-3)
2. Push the ← or → keys to scroll to another page.
3. Press **ENTER** if the desired block is selected.

```
INTERNAL # PATTERN
kHz/Hz
15.6/50 PAL
15.6/60 NTSC
31.2/50 EDTV
31.5/60 IDTV
31.2/50 HDTV EUREKA
31.5/60 HDTV ATV

Select with ↑ or ↓
scroll with ← or →
<ENTER> to accept
<EXIT> to return
```

Menu 8-3



The menus in this manual are created for an external source, connected to one of the inputs, and the 'Gen-locked Pattern' is selected.

## 8.4 Random Access mode selection menu

### Possibilities

This is the main menu for the Random Access adjustment mode.

Through this menu, the following adjustments and features are accessible :

- Picture tuning
- Geometry
- Convergence
- Color select

```
RANDOM ACCESS
ADJUSTMENT MODE

PICTURE TUNING
GEOMETRY
CONVERGENCE
COLOR SELECT

Select with ↑ or ↓
then <ENTER>
<EXIT> to return
```

Menu 8-4

## 8.5 Picture Tuning

### Overview

- Starting up Picture Tuning
- Color Balance
- Sync mode: Fast/Slow
- Decoding
- Port 2 Video/S-Video (Optional)
- Peaking
- Line Multiplier Settings



## 8.5.1 Starting up Picture Tuning

### How to start up Picture Tuning?

1. Push the cursor key  $\uparrow$  or  $\downarrow$  to highlight *Picture Tuning* and press **ENTER** to select. (menu 8-5)

The *Picture Tuning* menu will be displayed. (menu 8-6)

Depending on the input source, this menu will display different items:

- Color Balance
- Sync: Slow/Fast
- Decoding EBU/IRE
- Port 2: Video/S-Video
- Line Multiplier
- Peaking

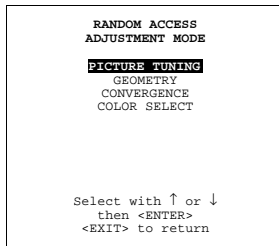

Menu 8-5

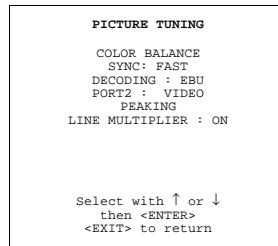

Menu 8-6

## 8.5.2 Color Balance

### 8.5.2.1 Selecting the Color Balance

#### What can be done?

The Color Balance function is used to select or adjust the color temperature of a projected white image by the projector.

The Color Balance can be adjusted on two different ways:

- By means of a fixed color balance. You have the choice between 3200 K (reddish), 5400 K, 6500 K (white) or 9300 K (bluish).
- By means of a custom white and black balance.

#### How to select Color Balance

1. Push the cursor key  $\uparrow$  or  $\downarrow$  to highlight *Color Balance*. (menu 8-7)
2. Press **ENTER** to select.

The color balance menu will be displayed. (menu 8-8)

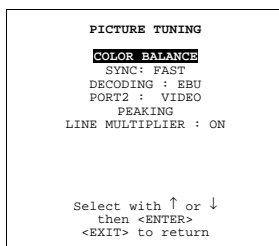

Menu 8-7

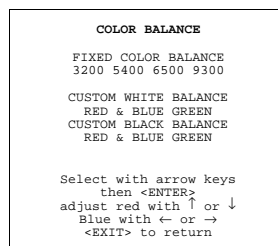

Menu 8-8

### 8.5.2.2 Set a Fixed Color Balance

#### How to select

1. Highlight one of the 4 preprogrammed color temperatures with the cursor keys. (menu 8-9)
2. Press **ENTER** to display the image with the desired color balance.

```
          COLOR BALANCE

FIXED COLOR BALANCE
3200 5400 6500 9300

CUSTOM WHITE BALANCE
RED & BLUE GREEN
CUSTOM BLACK BALANCE
RED & BLUE GREEN

Select with arrow keys
then <ENTER>
adjust red with ↑ or ↓
Blue with ← or →
<EXIT> to return
```

Menu 8-9

### 8.5.2.3 Custom Color Balance, White Balance adjustment

#### How to adjust

1. Push the cursor keys ↑, ↓, ← or → to select *Red & Blue* below *Custom white Balance*. (menu 8-10)
2. Press **ENTER** to activate the adjustment.
3. Push the cursor key ↑ or ↓ to adjust the red gain.
4. Push the cursor key ← or → to adjust the blue gain.  
A bar scale indicates the amount of adjustment.
5. Press **ENTER** to return to the Color Balance menu.
6. Push the cursor keys ↑, ↓, ← or → to select *Green* below *Custom white Balance*.
7. Press **ENTER** to activate the adjustment.
8. Push the cursor key ↑ or ↓ to adjust the green gain.
9. Press **ENTER** to return to the Color Balance menu.

```
          COLOR BALANCE

FIXED COLOR BALANCE
3200 5400 6500 9300

CUSTOM WHITE BALANCE
RED & BLUE GREEN
CUSTOM BLACK BALANCE
RED & BLUE GREEN

Select with arrow keys
then <ENTER>
adjust red with ↑ or ↓
Blue with ← or →
<EXIT> to return
```

Menu 8-10

### 8.5.2.4 Custom Color Balance, Black Balance adjustment

#### How to adjust

1. Push the cursor keys ↑, ↓, ← or → to select *Red & Blue* below *Custom black Balance*. (menu 8-11)
2. Press **ENTER** to activate the adjustment.
3. Push the cursor key ↑ or ↓ to adjust the red cut-off.
4. Push the cursor key ← or → to adjust the blue cut-off.  
A bar scale indicates the amount of adjustment.
5. Press **ENTER** to return to the Color Balance menu.
6. Push the cursor keys ↑, ↓, ← or → to select *Green* below *Custom black Balance*.
7. Press **ENTER** to activate the adjustment.
8. Push the cursor key ↑ or ↓ to adjust the green cut-off.
9. Press **ENTER** to return to the Color Balance menu.

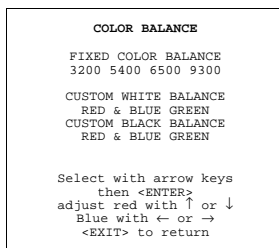

Menu 8-11

### 8.5.3 Sync mode: Fast/Slow

#### What can be done?

The Sync function is used to minimize horizontal jittering or tearing at the top to the displayed image.



**The Sync Slow/Fast function is only available for RGBS, RGsB, component, tri level and component tri level sources.**

#### How to adjust the Sync mode?

1. Push the cursor key ↑ or ↓ to highlight *Sync*. (menu 8-12)
2. Press **ENTER** to toggle between *Fast* or *Slow*.

**Note:** *Sync is normally set to Slow. The Fast position is used to compensate for unsteady sync pulses from older video playback equipment.*

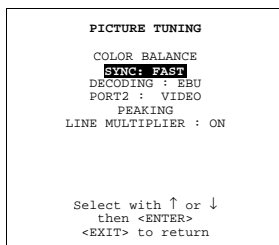

Menu 8-12

### 8.5.4 Decoding

#### What can be done?



**Only for NTSC signals.**

## 8. Random Access Adjustment Mode

---

The possibility is offered to decode the NTSC video signals via the normal American IRE standard or via the European EBU standard. How to set up ?

### How to set up ?

1. Push the cursor key ↑ or ↓ to select *Decoding*. (menu 8-13)
2. Press **ENTER** to toggle between IRE and EBU.

EBU      European standard of decoding color images  
IRE      American standard of decoding color images

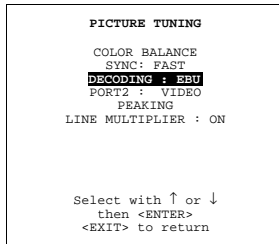

Menu 8-13

### 8.5.5 Port 2 Video/S-Video (Optional)

#### What can be done?

Port 2 can be used as Video or S-Video input.

#### How to configure Port 2?

1. Push the cursor key ↑ or ↓ to highlight *Port2*. (menu 8-14)
2. Press **ENTER** to toggle between *Video* or *S-Video*.

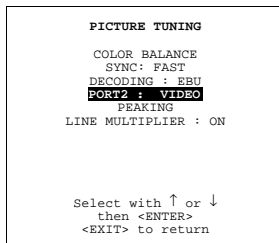

Menu 8-14

### 8.5.6 Peaking

#### What can be done?

Peaking improves the contours in an projected image.



The Peaking function is only available for RGBS, RGsB, component, tri level and component tri level sources.

---

## How to adjust Peaking?

1. Push the cursor key  $\uparrow$  or  $\downarrow$  to highlight *Peaking* and press **ENTER**. (menu 8-15)

**Note:** During the creation of new settings for a RGB source the corresponding peaking is switched on as default.

The *Peaking* menu will be displayed. (menu 8-16)

The following frequency areas are available:

Low Frequency Peaking	15–45Hz
Mid Frequency Peaking	45–85Hz
High Frequency Peaking	85–110Hz

2. Push the cursor key  $\uparrow$  or  $\downarrow$  to select the desired frequency area or off and press **ENTER** to activate.
3. Press **EXIT** to return to the *Picture Tuning* menu.

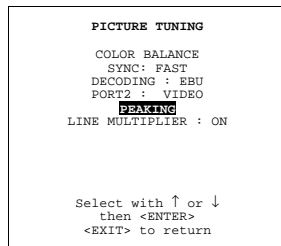

Menu 8-15

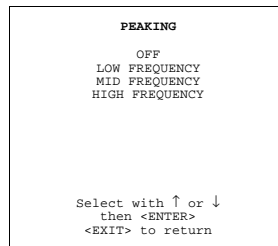

Menu 8-16

## 8.5.7 Line Multiplier Settings

### Overview

- Starting up Line Multiplier settings
- Switching the multiplier ON/OFF
- Motion Processing On/Off
- Output Mode
- Video Equalizing
- Noise Reduction
- Contrast Enhancement
- Split Screen On/Off
- Advanced Settings

### 8.5.7.1 Starting up Line Multiplier settings

#### What can be done?

The multiplier eliminates the video line patterns and improves the image stability.

In addition:

- The time base correction virtually eliminates the timing jitter caused by the common videocassette recorders.
- De-interlacing gets rid of line flicker.
- Film mode processing makes sure that material that has been converted from 24 Hz cinema to video (2:2 and 3:2 pull down) is displayed without artifacts.
- Dynamic noise reduction can be used to improve noisy video sources.
- Static contrast enhancement allows the user to adjust the image contrast to personal taste.
- Several detail-enhancing filters bring out details.



**Line multiplying is only possible for Video, S-Video, Component Video images on standard line frequency and RGB signals on 15 kHz.**

**The setting of the line multiplier will be saved together with the source number. Each time this source number is selected, the last saved version will be loaded.**

### How to start up the Line Multiplier settings?

1. Push the cursor key ↑ or ↓ to highlight *Line Multiplier* and press **ENTER** to select. (menu 8-17)

The *Image Processing* menu will be displayed. (menu 8-18)

```
PICTURE TUNING
COLOR BALANCE
SYNC: FAST
DECODING : EBU
PORT2 : VIDEO
PEAKING
LINE MULTIPLIER : ON

Select with ↑ or ↓
then <ENTER>
<EXIT> to return
```

Menu 8-17

```
IMAGE PROCESSING
LINE MULTIPLIER : ON
MOTION PROCESSING: ON

OUTPUT MODE
VIDEO EQUALIZING
NOISE REDUCTION
CONTRAST ENHANCEMENT

SPLIT SCREEN: OFF

ADVANCED SETTINGS
Select with ↑ or ↓
then <ENTER>
<EXIT> to return
```

Menu 8-18

### 8.5.7.2 Switching the multiplier ON/OFF

#### How to switch

1. Push the cursor key ↑ or ↓ to select *Line Multiplier*. (menu 8-19)
2. **ENTER** to toggle between *Line Multiplier : ON* and *Line Multiplier : OFF*.

When the line multiplier is on, all items in the menu are accessible.

```
IMAGE PROCESSING
LINE MULTIPLIER : ON
MOTION PROCESSING: ON

OUTPUT MODE
VIDEO EQUALIZING
NOISE REDUCTION
CONTRAST ENHANCEMENT

SPLIT SCREEN: OFF

ADVANCED SETTINGS
Select with ↑ or ↓
then <ENTER>
<EXIT> to return
```

Menu 8-19

### 8.5.7.3 Motion Processing On/Off

#### What can be done?

With this function it is possible to recognize whether the source material was originally film or video. That prevents the creation of motion artifacts.

#### How to toggle Motion Processing On/Off?

1. Push the cursor key ↑ or ↓ to highlight *Motion Processing*. (menu 8-20)
2. Press **ENTER** to toggle *Motion Processing* On/Off.
3. Press **EXIT** to return to the *Picture Tuning* menu.

```
IMAGE PROCESSING
LINE MULTIPLIER : ON
MOTION PROCESSING: ON

OUTPUT MODE
VIDEO EQUALIZING
NOISE REDUCTION
CONTRAST ENHANCEMENT

SPLIT SCREEN: OFF

ADVANCED SETTINGS
Select with ↑ or ↓
then <ENTER>
<EXIT> to return
```

Menu 8-20

### 8.5.7.4 Output Mode

#### What can be done?

Within the output mode menu, it is possible to select a new output mode for a given input signal.

The input signal can be:

- interlaced.
- non-interlaced.

#### How to adjust the Output Mode?

1. Push the cursor key  $\uparrow$  or  $\downarrow$  to highlight *Output Mode* and press **ENTER** to select. (menu 8-21)  
If your input signal is PAL or SECAM signal following menu will be displayed: (menu 8-22)  
If it is a NTSC signal following menu will be displayed: (menu 8-23)
2. Push the cursor key  $\uparrow$  or  $\downarrow$  to highlight the desired scan rate e.g. *100Hz 625 Lines NI* and press **ENTER** to activate. (menu 8-24)

50Hz	Vertical frequency of the image
1250 Lines	Quantity of horizontal lines
N I = Non Interlaced = Progressive Scan	Interlace mode

3. Press **EXIT** to return to the *Image Processing* menu.

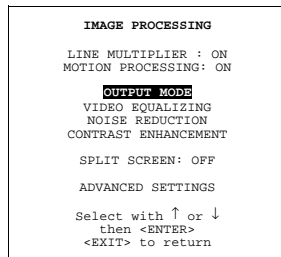

Menu 8-21

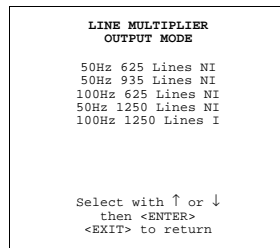

Menu 8-22

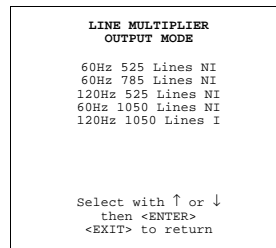

Menu 8-23

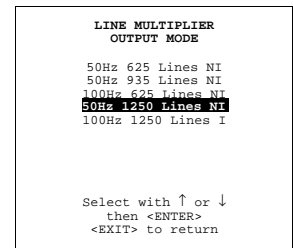

Menu 8-24

### 8.5.7.5 Video Equalizing

#### What can be done?

The sharpness of the image can be adjusted for 3 frequency bands (low, medium and high) separately. In addition to the 7 preprogrammed factory presets a customized adjustment of the sharpness for 3 ranges is also possible.

#### How to adjust Video Equalizing?

1. Push the cursor key  $\uparrow$  or  $\downarrow$  to highlight *Video Equalizing* and press **ENTER** to select. (menu 8-25)  
The *Video Equalizing* menu will be displayed. (image 8-1)
2. Push the  $\leftarrow$  or  $\rightarrow$  keys to select the desired frequency band (Low, Mid or High) or the Factory Preset : x.
3. Push the cursor key  $\uparrow$  or  $\downarrow$  to adjust the sharpness in the chosen frequency band (Low, Mid or High) or to scroll through the factory presets (x = 1 to 7).  
**Note:** *Factory preset 8 is equal to the custom adjustment as made with low, mid and high.*
4. Press **EXIT** to return to the *Image Processing* menu.

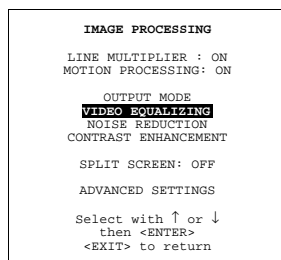

Menu 8-25



Image 8-1  
Video Equalizing menu

### 8.5.7.6 Noise Reduction

#### What can be done?

Noisy, lower quality video images can be ameliorated by use of the Noise Reduction feature.

#### How to adjust Noise Reduction?

1. Push the cursor key  $\uparrow$  or  $\downarrow$  to highlight *Noise Reduction* and press **ENTER** to select. (menu 8-26)

The Dynamic Noise Reduction bar scale will be displayed. (image 8-2)

2. Push the cursor key  $\uparrow$  or  $\downarrow$  to adjust the Noise Reduction.
3. Press **EXIT** to return to the *Image Processing* menu.

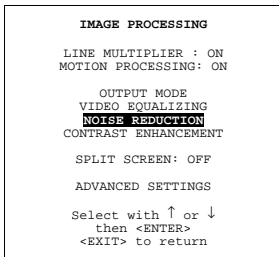

Menu 8-26

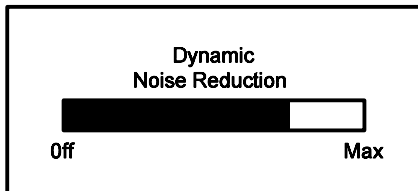

Image 8-2  
Dynamic Noise Reduction bar scale

### 8.5.7.7 Contrast Enhancement

#### What can be done?

Enhancing the contrast results in a more dynamic image.



### How to adjust the Contrast Enhancement?

1. Push the cursor key  $\uparrow$  or  $\downarrow$  to highlight *Contrast Enhancement* and press **ENTER** to select. (menu 8-27)  
The Contrast Enhancement bar scale will be displayed. (image 8-3)
2. Push the cursor key  $\uparrow$  or  $\downarrow$  to adjust the Contrast Enhancement.
3. Press **EXIT** to return to the *Image Processing* menu.

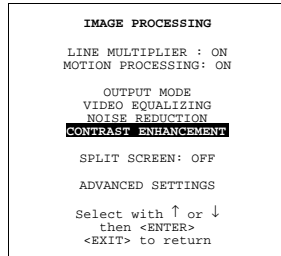

Menu 8-27

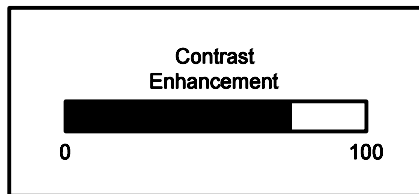
Image 8-3  
Contrast Enhancement bar scale

#### 8.5.7.8 Split Screen On/Off

##### What can be done?

When the split screen is 'on', the left half of the image will be displayed without enhancements, the right half shows the image with all selected image processing enabled.

##### How to toggle Split Screen On/Off?

1. Push the cursor key  $\uparrow$  or  $\downarrow$  to highlight *Spit Screen*. (menu 8-28)
2. Press **ENTER** to toggle *Split Screen On/Off*.

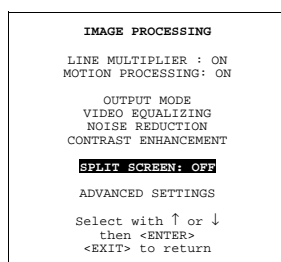

Menu 8-28

#### 8.5.7.9 Advanced Settings

##### Overview

- Starting Up Advanced Settings
- Time Base Correction
- Luminance Delay
- Vertical Sync Reference
- Clamp Gating
- Limo Pro Options
- Factory Presets

### 8.5.7.9.1 Starting Up Advanced Settings

#### How to start up Advanced Settings?

1. Push the cursor key  $\uparrow$  or  $\downarrow$  to highlight *Advanced Settings* and press **ENTER** to select. (menu 8-29)

The *Advanced settings* menu will be displayed. (menu 8-30)

```
IMAGE PROCESSING
LINE MULTIPLIER : ON
MOTION PROCESSING: ON

OUTPUT MODE
VIDEO EQUALIZING
NOISE REDUCTION
CONTRAST ENHANCEMENT

SPLIT SCREEN: OFF
ADVANCED SETTINGS

Select with  $\uparrow$  or  $\downarrow$ 
then <ENTER>
<EXIT> to return
```

Menu 8-29

```
LINE MULTIPLIER

TIME BASE CORRECTION
LUMINANCE DELAY
V SYNC REF: INDIRECT
CLAMP GATING: OFF

LIMO PLUS OPTIONS
FACTORY PRESET

WARNING: ADVANCED
ADJUSTMENT SHOULD BE
PERFORMED ONLY BY QUALIFIED
PERSONNEL

Select with  $\uparrow$  or  $\downarrow$ 
then <ENTER>
<EXIT> to return
```

Menu 8-30

### 8.5.7.9.2 Time Base Correction

#### What can be done?

With the Time Base Correction function it is possible to cleanup low quality videotape noise to obtain a more stable image.

#### How to toggle Time Base Correction On/Off

1. Push the cursor key  $\uparrow$  or  $\downarrow$  to highlight *Time Base Correction*. (menu 8-31)
2. Press **ENTER** to toggle *Time Base Correction* On/Off.

```
LINE MULTIPLIER

TIME BASE CORRECTION
LUMINANCE DELAY
V SYNC REF: INDIRECT
CLAMP GATING: OFF

LIMO PLUS OPTIONS
FACTORY PRESET

WARNING: ADVANCED
ADJUSTMENT SHOULD BE
PERFORMED ONLY BY QUALIFIED
PERSONNEL

Select with  $\uparrow$  or  $\downarrow$ 
then <ENTER>
<EXIT> to return
```

Menu 8-31

### 8.5.7.9.3 Luminance Delay

#### When is it necessary?

When a color shift is recognized on the screen. e.g. if color bars are projected and a line between the colors is recognized.

### How to adjust Luminance Delay?

1. Push the cursor key  $\uparrow$  or  $\downarrow$  to highlight *Luminance Delay* and press **ENTER** to select. (menu 8-32)  
The Luminance Delay bar scale will be displayed. (image 8-4)
2. Push the cursor key  $\uparrow$  or  $\downarrow$  to adjust the Luminance Delay until the color shift is eliminated.
3. Press **EXIT** to return to the *Line Multiplier* menu.

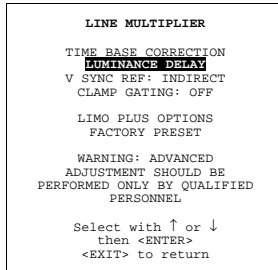

Menu 8-32

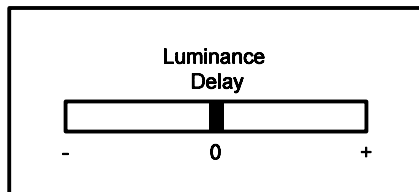
Image 8-4  
Luminance Delay bar scale

#### 8.5.7.9.4 Vertical Sync Reference

##### What can be done?

The Vertical Sync Reference can be set in 2 modes:

Direct	This sync processing has the disadvantage that glitches and other disturbances in the video signal sometimes get passed and hence may cause problems in the image.
Indirect	This sync processing throws away any disturbances that are not really sync signals. By source switching a rolling effect on the image can occur. This sync processing is preferred especially with low quality material.

##### How to toggle Vertical Sync Reference Direct/Indirect?

1. Push the cursor key  $\uparrow$  or  $\downarrow$  to highlight *Vertical Sync Reference*. (menu 8-33)
2. Press **ENTER** to toggle Vertical Sync Reference Direct/Indirect.

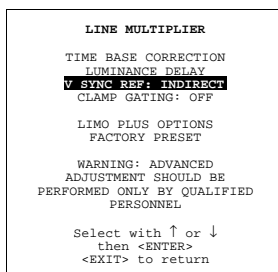

Menu 8-33

#### 8.5.7.9.5 Clamp Gating

##### When is it necessary?

Clamp Gating is useful when protection signals are present in the vertical interval of the video signal (macrovision), that would otherwise confuse the Limo Pro, causing horizontal brightness differences near the top of the screen.

### How to toggle Clamp Gating On/Off?

1. Push the cursor key  $\uparrow$  or  $\downarrow$  to highlight *Clamp Gating*. (menu 8-34)
2. Press **ENTER** to toggle Clamp Gating On/Off.  
**Note:** *Default Clamp Gating is set to Off.*

*Suggested default settings:*

Time Base Correction	On
Vertical Sync Reference	Indirect
Clamp Gate	Off

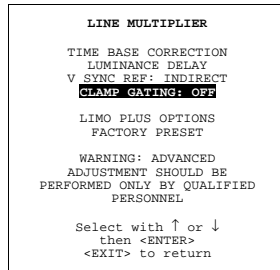

Menu 8-34

### 8.5.7.10 Limo Pro Options

#### Overview

- Starting Up Limo Pro Options
- Coring
- LTI
- CTI

#### 8.5.7.10.6 Starting Up Limo Pro Options

##### When available?

This menu item is only available when the projector is equipped with a line multiplier.

##### How to start up Limo Pro Options?

1. Push the cursor key  $\uparrow$  or  $\downarrow$  to highlight *Limo Pro Options* and press **ENTER** to select. (menu 8-35)  
The *Limo Pro Options* menu will be displayed.

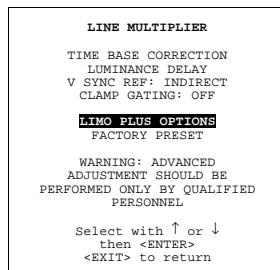

Menu 8-35

#### 8.5.7.10.7 Coring

##### What can be done?

With coring, a noise threshold will be set for all filters.

### How to adjust Coring?

1. Push the cursor key ↑ or ↓ to highlight *Coring* and press **ENTER** to select. (menu 8-36)  
The Coring bar scale will be displayed. (image 8-5)
2. Push the cursor key ↑ or ↓ to adjust the Coring.
3. Press **EXIT** to return to the *Limo Pro Options* menu.

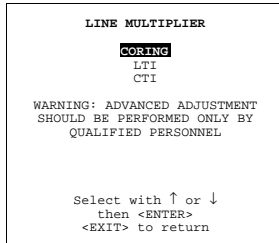

Menu 8-36

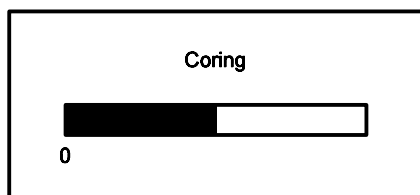

Image 8-5

#### 8.5.7.10.8 LTI



#### LTI

Luminance transient improvement.

#### What can be done?

This function makes the luminance transients sharper (from dark areas to highlight areas) without overshoot, undershoot or ringing.

#### Without LTI adjustment

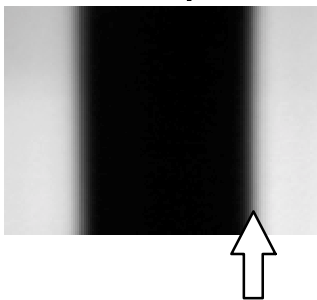

#### With LTI adjustment

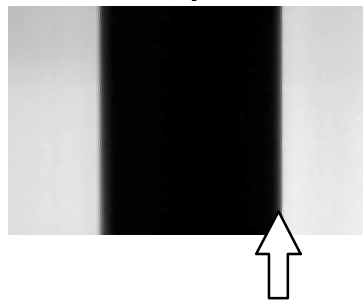

Adjust LTI for max black and white transient improvement

Image 8-6  
 LTI basic principle

## 8. Random Access Adjustment Mode

### How to adjust LTI?

1. Push the cursor key  $\uparrow$  or  $\downarrow$  to highlight *LTI* and press **ENTER** to select. (menu 8-37)  
The Coring bar scale will be displayed. (image 8-7)
2. Push the cursor key  $\uparrow$  or  $\downarrow$  to adjust the LTI value.  
**Note:** Only 7 steps are possible.
3. Press **EXIT** to return to the *Limo Pro Options* menu.

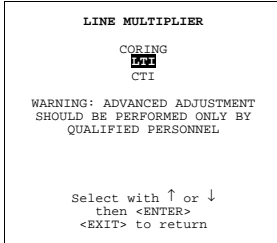

Menu 8-37

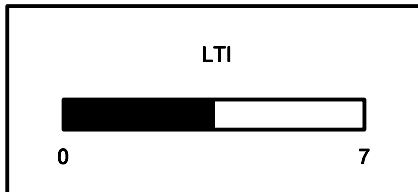

Image 8-7  
LTI bar scale

### 8.5.7.10.9 CTI



#### CTI

Color transient improvement. To improve the transition from one color to another.

#### What can be done?

This function makes the chrominance transients (from one color to another) sharper without overshoot, undershoot or ringing.

#### Without CTI adjustment

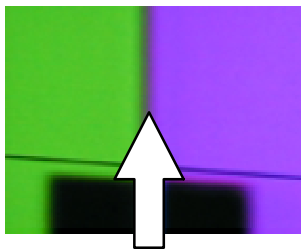

#### With CTI adjustment

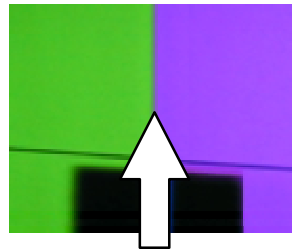

#### Adjust CTI for max color transient improvement

Image 8-8  
CTI principle

**How to adjust CTI?**

1. Push the cursor key ↑ or ↓ to highlight *CTI* and press **ENTER** to select. (menu 8-38)  
The LTI bar scale will be displayed. (image 8-9)
2. Push the cursor key ↑ or ↓ to adjust the CTI value.  
**Note:** Only 7 steps are possible.
3. Press **EXIT** to return to the *Limo Pro Options* menu.

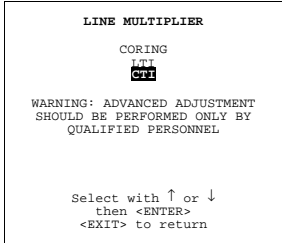

Menu 8-38

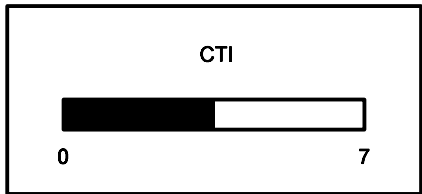

Image 8-9  
CTI bar scale

**8.5.7.10 Factory Presets**

**What can be done?**

All settings for the Line Multiplier can be set to the Factory Presets.  
These Factory Presets settings are:

Time Base Correction	On
Luminance Delay	0
Vertical Sync Reference	Indirect
Clamp Gating	Off

**How to set to the Factory Presets?**

1. Push the cursor key ↑ or ↓ to highlight *Factory Presets*. (menu 8-39)
2. Press **ENTER** to set to the Factory Presets?
3. Press **EXIT** to return to the *Image Processing* menu.

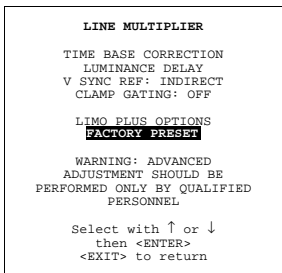

Menu 8-39

---

## 8.6 Geometry Adjustments

---

### Overview

- Starting Up Geometry
- Horizontal Phase Adjustment
- Raster Shift Adjustment
- Left-Right (East-West) Adjustment
- Top-Bottom (Nord-South) Adjustment
- Size Adjustment
- Vertical Linearity Adjustment
- Blanking Adjustments

### 8.6.1 Starting Up Geometry

#### What can be done?

The geometry adjustments have to be done only on the green image. These adjustments are automatically implemented for the other color images.

The following adjustments can be adjusted:

- Left-Right (East-West) Corrections.
- Top-Bottom (North-South) Corrections.
- Blanking.
- Horizontal Amplitude.
- Vertical Amplitude.
- Vertical Linearity .
- Horizontal Phase.



The convergence corrections are disabled during geometry corrections. The blanking corrections are only enabled during the blanking adjustments.

---

#### How to start up Geometry?

1. Push the cursor key  $\uparrow$  or  $\downarrow$  to highlight *Geometry* and press **ENTER** to select. (menu 8-40)

The *Geometry* menu will be displayed. (menu 8-41)

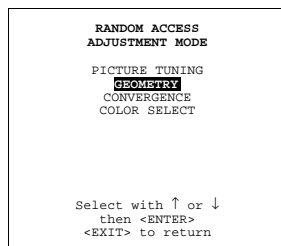

Menu 8-40

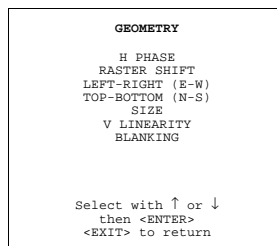

Menu 8-41

### 8.6.2 Horizontal Phase Adjustment



No horizontal phase adjustment is available on the Internal # Pattern. If the genlocked pattern was selected during the start up of the random access mode, the external source will be displayed.

---



### How to adjust the Horizontal Phase?

1. Push the cursor key  $\uparrow$  or  $\downarrow$  to highlight *Horizontal Phase* and press **ENTER** to select. (menu 8-42)  
The Horizontal Phase Text box will be projected in the middle of the external image. A bar scale and a number indicator (between 0 and 100) on the screen give a visual indication of the horizontal phase adjustment. (image 8-10)
2. If the raster shift is correctly adjusted, the H Phase text box is projected in the middle of the raster. At that moment, the "><" icon indicates the middle of the raster.  
Press the  $\leftarrow$  or  $\rightarrow$  keys to adjust the H Phase "><" icon to coincide with the middle of the projected image.
3. Press **EXIT** to return to the *Geometry* menu.

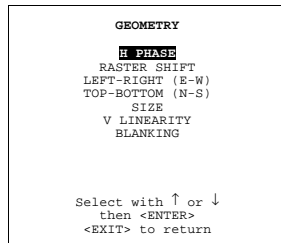

Menu 8-42

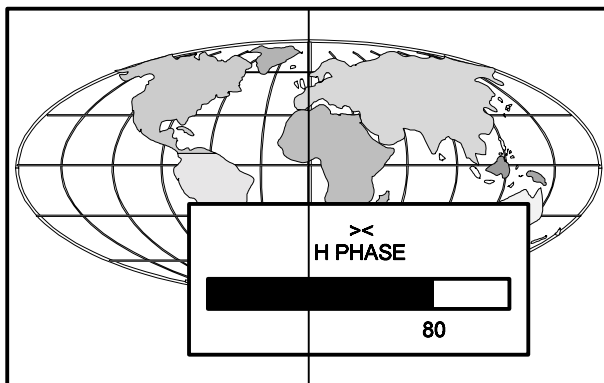
Image 8-10  
Horizontal Phase Text Box

### 8.6.3 Raster Shift Adjustment



It is necessary to look into the lenses to perform these adjustments. To avoid eye discomfort while looking into the lenses, reduce the contrast and gradually increase the brightness level until the raster becomes visible on the face of the CRT.

#### What has to be done?

The raster of the separate colors must be centered both horizontally and vertically on the center of the CRT surface. To center the raster, look into the lens of the respective color and use the cursor keys to move the raster.

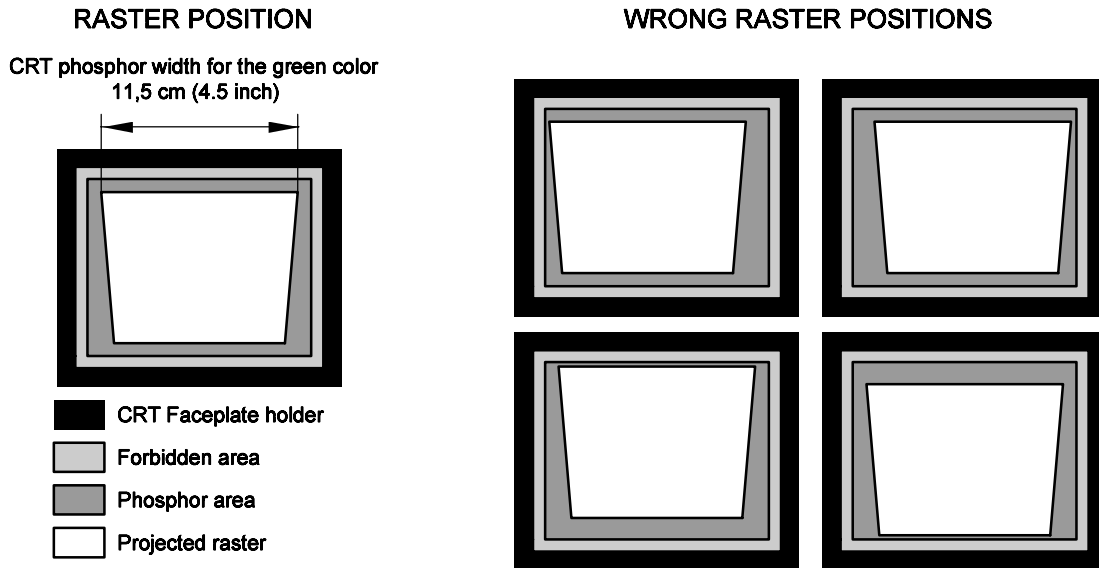
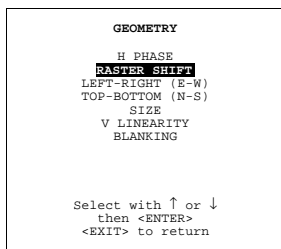

Image 8-11

### How to adjust the Raster Shift?

1. Push the cursor key  $\uparrow$  or  $\downarrow$  to highlight *Raster Shift* and press **ENTER** to select. (menu 8-43)  
The Raster Shift menu will be displayed.
2. First push the  $\uparrow$  or  $\downarrow$  keys to highlight *Coarse Green* and press **ENTER** to select. (menu 8-44)
3. Use the cursor keys to perform a Coarse Raster Shift and press **ENTER** to continue.
4. Push the  $\uparrow$  or  $\downarrow$  keys to highlight *Coarse Red Horz* and press **ENTER** to select.
5. Use the cursor keys to shift the Red Raster until Red is almost on Green.
6. Repeat step 4 till 5 for *Coarse Blue Horz*.
7. If necessary repeat step 4 till 5 to perform a Fine Raster Shift until the colors math each other.  
**Note:** *Horizontal and Vertical shifts for Red and Blue should end up with a setting close to 50%. If these settings are significantly greater or lesser than 50%, contact a BARCO authorized service technician.*
8. Press **EXIT** to return to the *Geometry* menu.



Menu 8-43

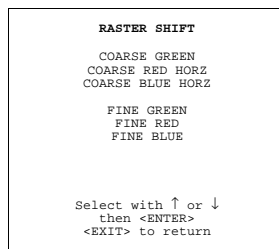

Menu 8-44

### 8.6.4 Left-Right (East-West) Adjustment

#### What can be adjusted ?

Left-right and center adjustments affect only the vertical lines of the projected image. The skew, the bow, the keystone and the seagull distortion can be adjusted.

## Start up

1. Push the cursor key ↑ or ↓ to highlight *LEFT-RIGHT*. (menu 8-45)
2. Press **ENTER** to select.

The Left-Right menu will be displayed. (menu 8-46)

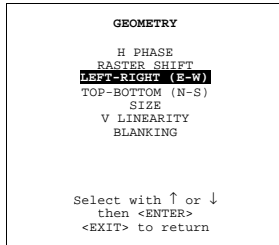

Menu 8-45

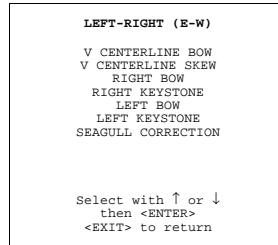

Menu 8-46



**Only the green image is displayed while making left-right adjustments. The red and blue images will automatically be corrected in the same manner.**

**Convergence corrections are automatically disabled for the duration of these adjustments.**

## Possible adjustments

The following adjustments can be executed

- Vertical centerline bow
- Vertical centerline skew
- side keystone (left-right)
- side bow (left-right)

All adjustment are indicated on the screen with the function name, a bar scale and a number between 0 and 100. Adjust the next alignments until the vertical lines are straight.

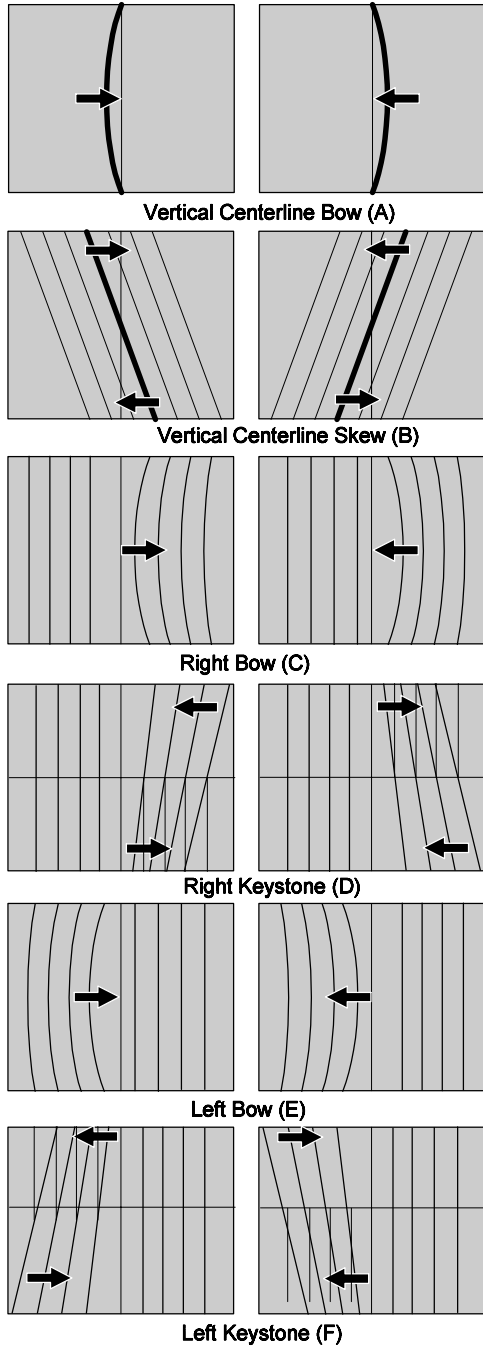

Image 8-12

- (A) Vertical Centerline bow
- (B) Vertical Centerline skew
- (C) Right bow
- (D) Right keystone
- (E) Left bow
- (F) Left keystone

### How to enter an alignment?

1. Push the cursor key  $\uparrow$  or  $\downarrow$  to highlight a function.
2. Press **ENTER** to activate this function.
3. Press **EXIT** to return.

### What can be done with the Seagull correction

Use this correction only if, after adjusting the vertical lines with the side bow or side keystone, still a 'S' deformation is visible on the left and the right side of the image.

The default value on the bar scale for this correction is 50.

**How to adjust the Seagull correction**

1. Push the cursor key ↑ or ↓ to highlight SEAGULL CORRECTION. (menu 8-47)
2. Press ENTER to activate.

Eliminate the deformation by pushing the cursor key ← or → until a straight line is obtained (image 8-13)

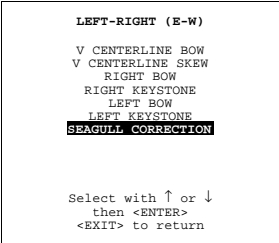

Menu 8-47

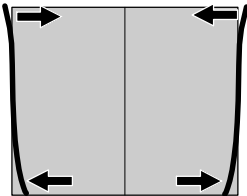

Image 8-13  
Seagull correction

**8.6.5 Top-Bottom (Nord-South) Adjustment**

**What can be adjusted ?**

Top-Bottom and center adjustments affect only the horizontal lines of the projected image. The skew, the bow, the keystone and the seagull deviation can be adjusted.

**Start up**

1. Push the cursor key ↑ or ↓ to highlight LEFT-RIGHT. (menu 8-48)
2. Press ENTER to select.

The Top-bottom menu will be displayed. (menu 8-49)

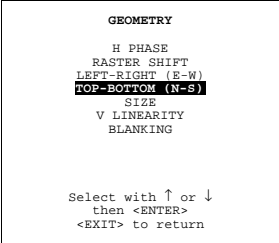

Menu 8-48

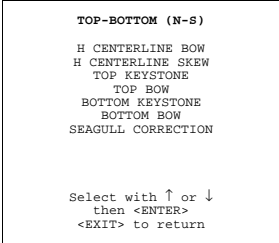

Menu 8-49



**Only the green image is displayed while making left-right adjustments. The red and blue images will automatically be corrected in the same manner.**

**Convergence corrections are automatically disabled for the duration of these adjustments.**

### **Possible adjustments**

The following adjustments can be executed

- Horizontal centerline bow
- Horizontal centerline skew
- Top bow
- Top keystone
- Bottom bow
- Bottom keystone

All adjustment are indicated on the screen with the function name, a bar scale and a number between 0 and 100. Adjust the next alignments until the vertical lines are straight.

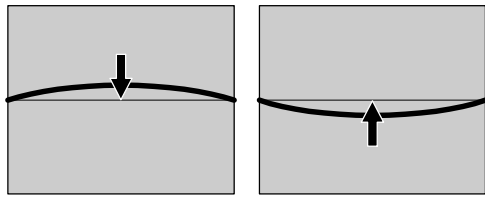

Horizontal Centerline Bow (A)

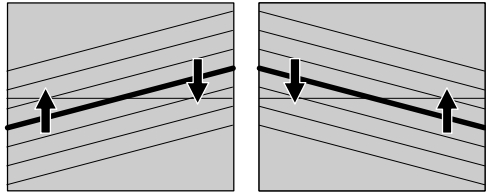

Horizontal Centerline Skew (B)

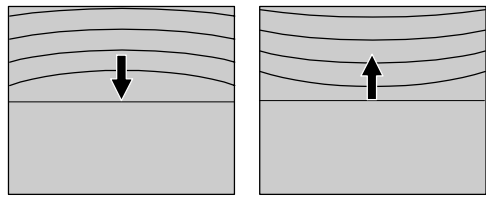

Top Bow (C)

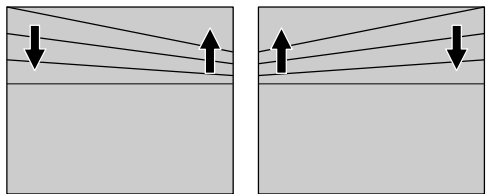

Top Keystone (D)

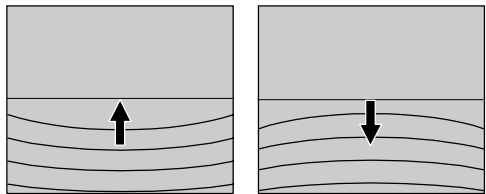

Bottom Bow (E)

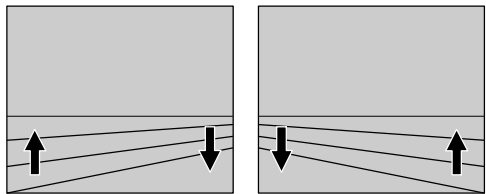

Bottom Keystone (F)

Image 8-14  
Top-Bottom corrections

- (A) Vertical centerline Bow
- (B) Vertical centerline Skew
- (C) Top Bow
- (D) Top Keystone
- (E) Bottom Bow
- (F) Bottom Keystone

### How to enter an alignment?

1. Push the cursor key ↑ or ↓ to highlight a function.
2. Press **ENTER** to activate this function.
3. Press **EXIT** to return.

### What can be done with the Seagull correction

Use this correction after the image has been adjusted with top and bottom bow and keystone. If still a deformation (like a seagull) on top and bottom of the image is visible, proceed to the seagull correction. Due to interaction, it is possible that the top and bottom bow have to be readjusted after adjusting the seagull correction to obtain an improved image.

The default value on the bar scale of this correction is 50.

### How to adjust the Seagull correction

1. Push the cursor key ↑ or ↓ to highlight SEAGULL CORRECTION. (menu 8-50)
2. Press **ENTER** to activate.

Eliminate the deformation by pushing the cursor key ← or → until a straight line is obtained (image 8-15)

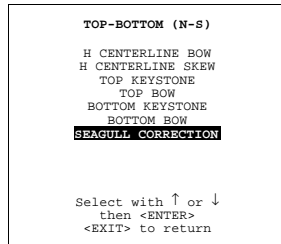

Menu 8-50

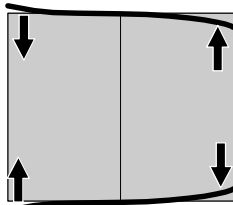

Image 8-15  
Seagull correction

## 8.6.6 Size Adjustment

### What can be done?

To adjust (correct) a little bit the horizontal and vertical picture size (when the projector is on its correct position) in regard with the installed screen.



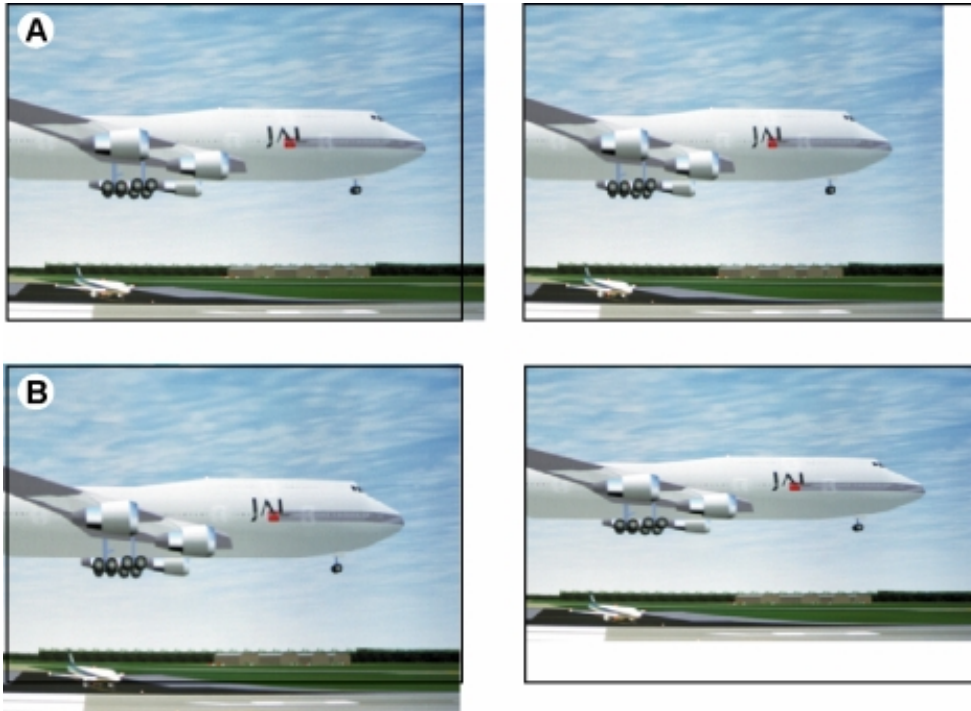

Image 8-16  
Size adjustment

- A Vertical size adjustment
- B Horizontal size adjustment



In order to avoid loss of resolution in the projected image and to ensure maximum CRT longevity, do not use an excessively small size setting.



If the internal # pattern was selected, this pattern remains on the screen, if the genlocked pattern was selected, the external source will be displayed.

### How to adjust the Size?

1. Push the cursor key  $\uparrow$  or  $\downarrow$  to highlight *Size* and press **ENTER** to select. (menu 8-51)  
A bar scale and a numeric indicator will help to gauge the size adjustment. (image 8-17)
2. Push the  $\leftarrow$  or  $\rightarrow$  keys to adjust the horizontal size until the exact image width is obtained. (image 8-18)
3. Push the  $\uparrow$  or  $\downarrow$  keys to adjust the vertical size until the exact image height is obtained. (image 8-19)
4. Press **EXIT** to return to the *Geometry* menu.

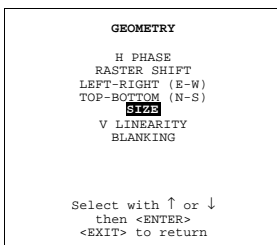

Menu 8-51

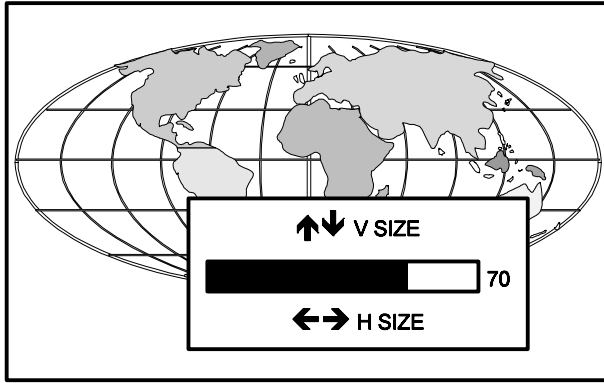

Image 8-17

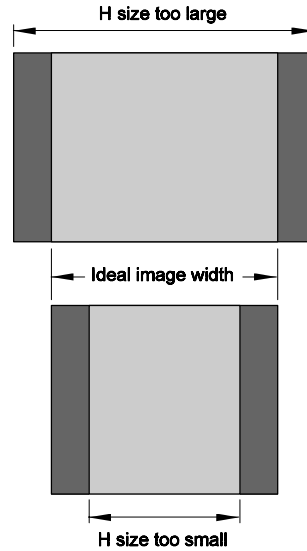

Image 8-18  
Horizontal Size Adjustment

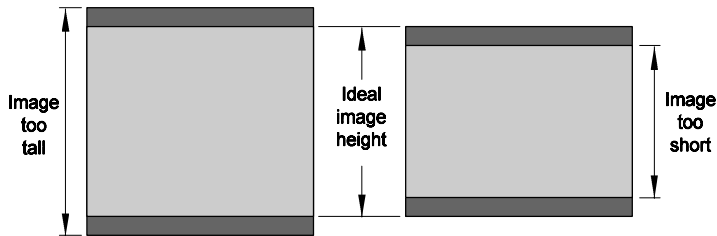

Image 8-19  
Vertical Size Adjustment

### 8.6.7 Vertical Linearity Adjustment

#### What can be done?

The vertical linearity adjustment function corrects for vertical non-linearities which extend from the center of the image to the top and bottom of the image.

#### Start up

1. Push the cursor key  $\uparrow$  or  $\downarrow$  to highlight *V Linearity*. (menu 8-52)
2. Press **ENTER** to activate.
3. Adjust the vertical linearity with the cursor keys until the distances between the horizontal lines of the set up pattern are equal from top to bottom. (image 8-20)

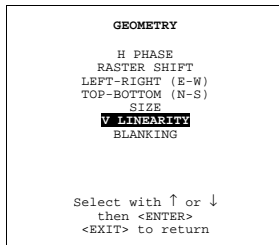

Menu 8-52

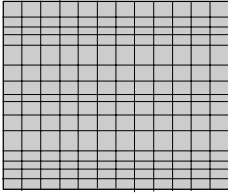

Image 8-20  
Vertical linearity

### 8.6.8 Blanking Adjustments

#### What can be done?

Blanking adjustments affect only the edges of the projected image and are used to frame the projected image on to the screen and to hide or black out unwanted information.

The following blanking adjustments are available:

- Top.
- Bottom.
- Left.
- Right.

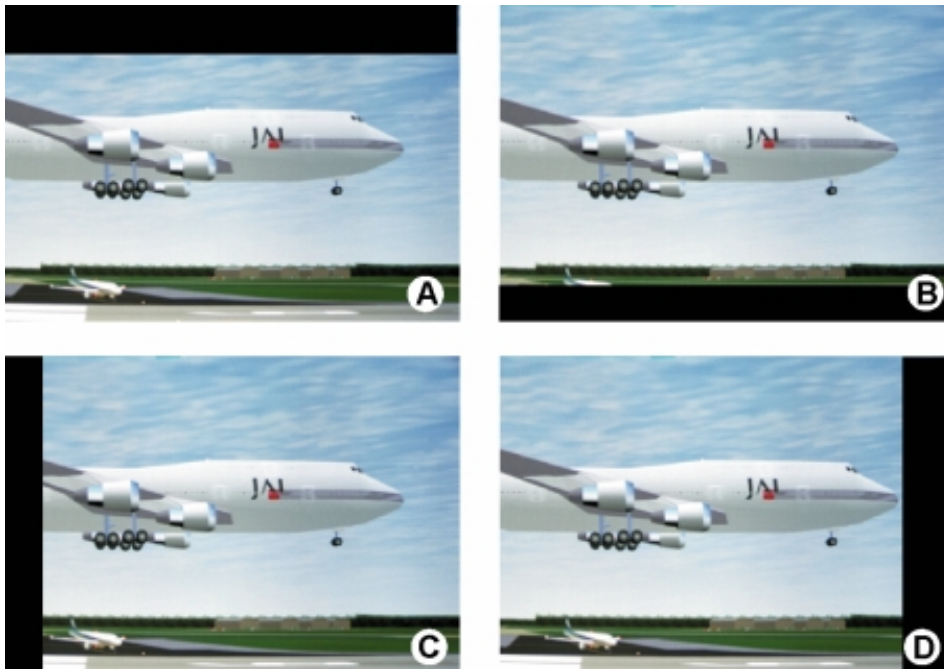

Image 8-21  
Blanking

- A Top Blanking
- B Bottom Blanking
- C Left Blanking
- D Right Blanking



If the internal # pattern was selected, this pattern remains on the screen.

If the genlocked pattern was selected, the external source will be displayed.

### How to adjust the Blanking?

1. Push the cursor key  $\uparrow$  or  $\downarrow$  to highlight *Blanking* and press **ENTER** to select. (menu 8-53)  
The *Blanking* menu will be displayed. (menu 8-54)
2. Push the cursor key  $\uparrow$  or  $\downarrow$  to highlight the desired blanking position and press **ENTER** to select. (image 8-22)
3. Push the cursor keys to adjust the blanking and press **ENTER** to confirm.
4. Press **EXIT** to return to the *Geometry* menu.

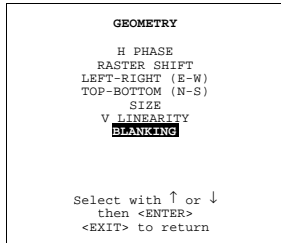

Menu 8-53

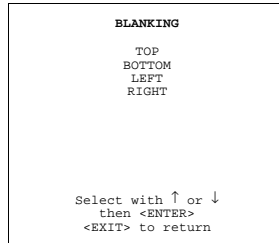

Menu 8-54

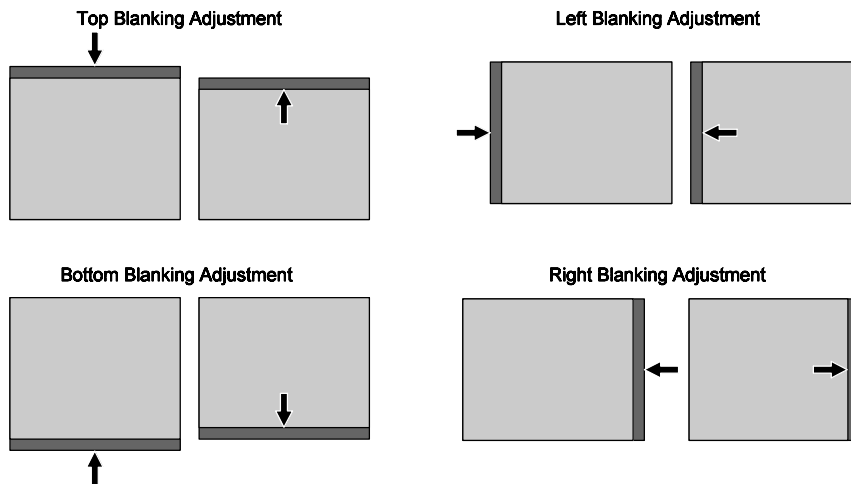

Image 8-22  
Blanking Adjustments

## 8.7 Convergence Adjustment

### Overview

- Starting Up Convergence
- Convergence Adjustment

#### 8.7.1 Starting Up Convergence

##### What has to be done?

Convergence adjustments affect both the horizontal and vertical lines of the setup pattern. These adjustments are performed on the green image first, if green convergence is available, until these lines are straight and then on the red image while superimposed on the green image and on the blue image while superimposed on the green image. Adjust the red and blue until they exactly match with the green lines.

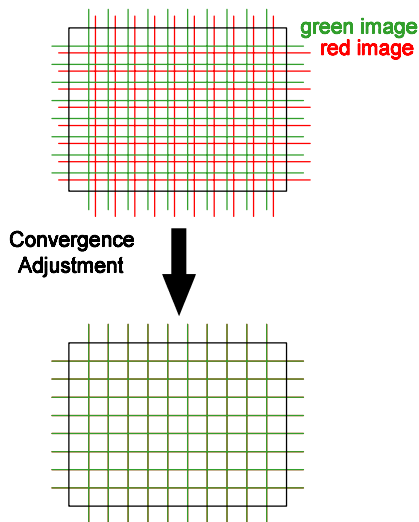

Image 8-23  
Convergence Adjustment

### Adjustment order

Adjust first the green only when available and continue with red on green and blue on green.

### How to start up Convergence?

1. Push the cursor key  $\uparrow$  or  $\downarrow$  to highlight *Convergence* and press **ENTER** to select. (menu 8-55)  
The *Convergence* menu will be displayed. (menu 8-56)

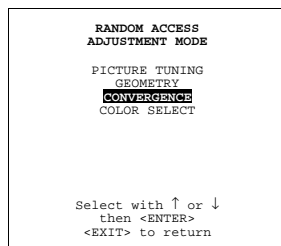

Menu 8-55

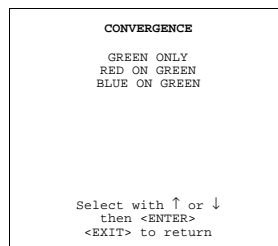

Menu 8-56

## 8.7.2 Convergence Adjustment

### Adjustment Order

When green convergence is available, start always with 'green only' and continue with 'red on green' and 'blue on green'.

### How to perform a Convergence Adjustment?

1. Push the cursor key  $\uparrow$  or  $\downarrow$  to highlight the desired adjustment press **ENTER** to select.
2. Use the cursor keys to select one of the 25 areas and press **ENTER** to confirm and to toggle the cursor keys to the adjustment mode. (image 8-24)  
**Tip:** For the best result, start by adjusting zone 1 and follow the default order as shown in the image.
3. Use the cursor keys to make horizontal or vertical adjustments in the selected zone.
4. Press **ENTER** to finish convergence adjustment and to toggle the cursor keys to the selection mode.
5. Repeat step 2 till 4 for each area that needs an adjustment.
6. Press **EXIT** to return to the *Convergence*.
7. Repeat the same procedure for Red on Green and Blue on Green.
8. Press **EXIT** to return to the *Random Access Adjustment Mode* menu.

## 8. Random Access Adjustment Mode

---

25	23	9	15	17
24	22	8	14	16
5	4	1	2	3
20	18	6	10	12
21	19	7	11	13

Image 8-24  
25 Coarse Convergence Areas

## 9. SERVICE MODE

### Overview

- Introduction
- Service Mode Overview
- Projector Set up
- Memory Management
- Common Settings
- I2C Diagnostics

### 9.1 Introduction

#### How to start up Service Mode?

1. Push the cursor key  $\uparrow$  or  $\downarrow$  to highlight *Service* and press **ENTER** to select. (menu 9-1)

The *Service* menu will be displayed. (menu 9-2)

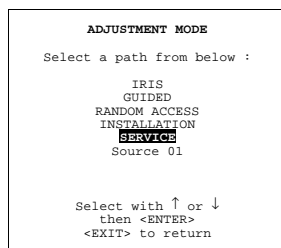

Menu 9-1

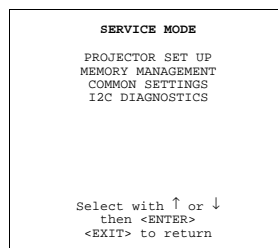

Menu 9-2



**Some items in the Service mode are password protected (when the password function is active). Enter your password to continue. All other password protected items are now also available if you stay in the adjustment mode.**

## 9.2 Service Mode Overview

---

### Service Mode Overview

- Projector Set Up
  - Identification
  - Total Run Time
  - Change Password
  - Change Language
  - Change Projector Address
  - Change Baudrate
  - Projector Warm Up
  - Power Up Mode
  - Common Address
  - BARCO Logo
- Memory Management
  - Copy a Block
  - Delete a Block
  - Deletion All Blocks
  - All Settings to Midposition
  - R & B Convergence Mid
  - GR Convergence Mid
- Common Settings
  - G2 Adjustment
  - CRT Run In Cycle
  - Projector Warm up
  - Memory Banks
- I<sup>2</sup>C Diagnostics

## 9.3 Projector Set up

---

### Overview

- Starting Up Projector Set-Up
- Identification
- Total Run Time
- Change Password
- Change Language
- Change Projector Address
- Change Baudrate
- Power Up Mode Operating/Stand-By
- Common Address
- Barco Logo



### 9.3.1 Starting Up Projector Set-Up

#### Start up

1. Push the cursor key  $\uparrow$  or  $\downarrow$  to highlight *Projector Set-Up* and press **ENTER** to select. (menu 9-3)

The *Projector Set-Up* menu will be displayed. (menu 9-4)

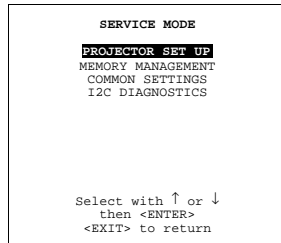

Menu 9-3

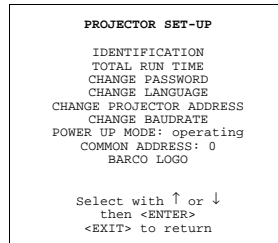

Menu 9-4

### 9.3.2 Identification

#### What can be seen?

The Identification screen gives information concerning:

- Projector address, to change the address of your projector, contact a qualified service technician.
- Software version.
- Configuration, possible installations: Front-ceiling, Front-table, Rear-ceiling, Rear-table.
- Baud rate PC: transfer speed for communication with an IBM PC (or compatible) or MAC. The baud rate of the projector must be the same as the baud rate of the connected computer. When there is a difference, contact a qualified service technician to make the appropriate changes.
- Text On/Off: indicates in operational mode if the bar scale and number indicator will be displayed and if warnings and failures will be displayed (ON: displayed, OFF: not displayed). The status can be changed by pressing the **TEXT** key once on the RCU.
- Serial No. : indicates the fabrication number of the projector. This number can be useful when calling for technical assistance.

#### How to start up Identification?

1. Push the cursor key  $\uparrow$  or  $\downarrow$  to highlight *Identification* and press **ENTER** to select. (menu 9-5)

The Identification screen will be displayed. (menu 9-6)

2. Press **EXIT** to return to the *Projector Set-Up* menu.

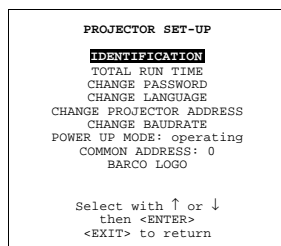

Menu 9-5

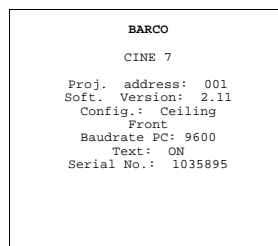

Menu 9-6

### 9.3.3 Total Run Time

#### What can be seen?

The total system run time since the first start up can be displayed plus the run time of the separate CRT's since the last reset.



**All projectors leave the factory after a burn-in period of approximately 100 hours.**

### How to start up Total Run Time?

1. Push the cursor key ↑ or ↓ to highlight *Total Run Time* and press **ENTER** to select. (menu 9-7)

The Total Run Time screen will be displayed, the System Runtime indicates the amount of time the projector has played since its first start up at the factory. (menu 9-8)

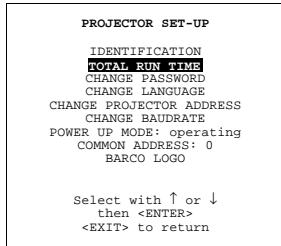

Menu 9-7

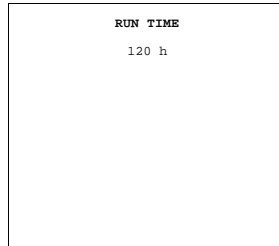

Menu 9-8

### 9.3.4 Change Password

#### What can be done?

The password code (4 digits) can be changed to a new one. This item is password protected. First the actual password should be entered before continuing.



**Password function is only active if the jumper on the controller is in the 'On' position. Contact a qualified BARCO technician to activate the password if needed.**

**The default password is 0000.**

#### How to Change the Password?

1. Push the cursor key ↑ or ↓ to highlight *Change Password* and press **ENTER** to select. (menu 9-9)  
**Note:** *If it is the first time you enter a password protected item, enter your password and press ENTER.*

The current Password will be displayed in the *Password* menu. (menu 9-10)

2. Push the ← or → keys to highlight the digit to be changed.
3. Press a numeric key to enter the new digit.
4. Repeat step 2 till 3 for the other digits.
5. Press **ENTER** to save the new password.

Before saving the new password, a confirmation screen will be displayed.

6. Press **ENTER** to confirm, press **EXIT** to cancel the saving.

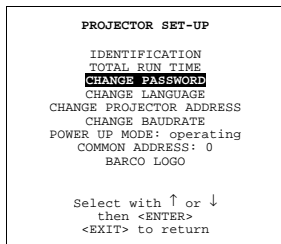

Menu 9-9

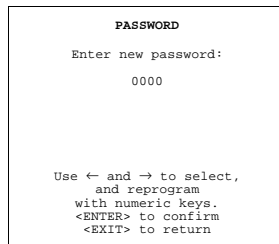

Menu 9-10

### 9.3.5 Change Language

#### What can be done?

The 'Change Language' function offers the possibility to change the language of the screen menus to English, Spanish, French and German.

### What can be done?

1. Push the cursor key ↑ or ↓ to highlight *Change Language*. (menu 9-11)
2. Press **ENTER** to display the language menu. (menu 9-12)
3. Push the cursor key ↑ or ↓ to highlight the desired language.
4. Press **ENTER** to change to that language.

```

PROJECTOR SET-UP

IDENTIFICATION
TOTAL RUN TIME
CHANGE PASSWORD
CHANGE LANGUAGE
CHANGE PROJECTOR ADDRESS
CHANGE BAUDRATE
POWER UP MODE: operating
COMMON ADDRESS: 0
BARCO LOGO

Select with ↑ or ↓
then <ENTER>
<EXIT> to return

```

Menu 9-11

```

LANGUAGE

ENGLISH
ESPAÑOL
FRANCAIS
DEUTSCH

Select with ↑ or ↓
then <ENTER>
<EXIT> to return

```

Menu 9-12

### 9.3.6 Change Projector Address

#### What can be done?

Every projector requires an individual address between 0 and 255. This address can be set by the software.

#### How to Change the Projector Address?

1. Push the cursor key ↑ or ↓ to highlight *Change Projector Password* and press **ENTER** to select. (menu 9-13)  
The current Projector Address will be displayed in the *Projector Address* menu. (menu 9-14)
2. Push the ← or → keys to highlight the digit to be changed.
3. Press a numeric key to enter the new digit.
4. Repeat step 2 till 3 for the other digits.
5. Press **ENTER** to save the new password.

```

PROJECTOR SET-UP

IDENTIFICATION
TOTAL RUN TIME
CHANGE PASSWORD
CHANGE LANGUAGE
CHANGE PROJECTOR ADDRESS
CHANGE BAUDRATE
POWER UP MODE: operating
COMMON ADDRESS: 0
BARCO LOGO

Select with ↑ or ↓
then <ENTER>
<EXIT> to return

```

Menu 9-13

```

PROJECTOR ADDRESS

Enter new projector
address:

000

Use ← and → to select,
and reprogram
with numeric keys.
Highest address is 255
<ENTER> to confirm
<EXIT> to return

```

Menu 9-14

### 9.3.7 Change Baudrate

#### What can be done?

The communication speed between projector and computer has 8 possible speeds. The baud rate speed can be software set up.

The following baud rates are available:

- 9600
- 4800
- 2400
- 1200
- 600
- 300
- 150
- 110



By default the Baudrate is set to 9600.

### How to Change the Baudrate?

1. Push the cursor key ↑ or ↓ to highlight *Change Baudrate* and press **ENTER** to select. (menu 9-15)  
The *Baudrate* menu will be displayed, the actual Baudrate will be highlighted. (menu 9-16)
2. Push the cursor key ↑ or ↓ to highlight the desired Baudrate and press **ENTER** to confirm.
3. Press **EXIT** to return to the *Projector Set-Up* menu.

```

PROJECTOR SET-UP
IDENTIFICATION
TOTAL RUN TIME
CHANGE PASSWORD
CHANGE LANGUAGE
CHANGE PROJECTOR ADDRESS
CHANGE BAUDRATE
POWER UP MODE: operating
COMMON ADDRESS: 0
BARCO LOGO

Select with ↑ or ↓
then <ENTER>
<EXIT> to return
    
```

Menu 9-15

```

BAUDRATE
Select new
baudrate:
9600 4800
2400 1200
600 300
150

Select with arrow
keys:
<ENTER> to accept
<EXIT> to return
    
```

Menu 9-16

### 9.3.8 Power Up Mode Operating/Stand-By

#### What can be done?

When pressing the power switch, the projector can start up in 'operating mode' or in 'stand-by mode'.

Operating	The projector start up and displays image.
Stand-By	The projector start up in stand-by and waits until the stand-by button or a digit key is pressed

#### How to toggle Power Up Mode Operating/Stand By?

1. Push the cursor key ↑ or ↓ to highlight *Power Up Mode ..* (menu 9-17)
2. Press **ENTER** to select to toggle between *Operating* and *Standby*.

```

PROJECTOR SET-UP
IDENTIFICATION
TOTAL RUN TIME
CHANGE PASSWORD
CHANGE LANGUAGE
CHANGE PROJECTOR ADDRESS
CHANGE BAUDRATE
POWER UP MODE: operating
COMMON ADDRESS: 0
BARCO LOGO

Select with ↑ or ↓
then <ENTER>
<EXIT> to return
    
```

Menu 9-17

### 9.3.9 Common Address

#### What can be done?

Every projector listens to a common address. This common address can be set to '0' or '1'. When a RCU is programmed with that common address, every projector with that same common address will follow up the commands given by that RCU.

#### Why 2 different Common Addresses?

The reason to have the choice to select between common addresses is, to avoid controlling of other IR controlled units, e.g. a TV set with standard common address 0.

---

### How to change the Common Address?

1. Push the ↑ or ↓ keys to highlight *Common Address*.
2. Press **ENTER** to toggle the Common Address between '0' and '1'. (menu 9-18)
3. Press **EXIT** to return to the *Service Mode* menu.

```
PROJECTOR SET-UP
IDENTIFICATION
TOTAL RUN TIME
CHANGE PASSWORD
CHANGE LANGUAGE
CHANGE PROJECTOR ADDRESS
CHANGE BAUDRATE
POWER UP MODE: operating
COMMON ADDRESS: 0
BARCO LOGO

Select with ↑ or ↓
then <ENTER>
<EXIT> to return
```

Menu 9-18

### 9.3.10 Barco Logo

#### What can be done?

The BARCO logo can be added to the image, in overlay or in background, on any place on the screen.



Continuous use of the BARCO logo damages the RED CRT.

---

### How to add the Barco Logo

1. Push the cursor key ↑ or ↓ to highlight *Barco Logo*. (menu 9-19)
2. Press **ENTER** to select.

The BARCO logo menu will be displayed on the screen. (menu 9-20)

Within this menu, four toggle settings are available.

- Mode[ON/OFF]            Select mode and toggle with **ENTER** between ON and OFF
- ON : BARCO logo will be displayed on the screen when leaving the adjustment mode. To position the logo on the screen, push the cursor key up, down, to the left or to the right until the desired position is reached.
- OFF : No BARCO logo displayed on the screen when leaving the adjustment mode.
- Size[ON/OFF]            Select size and toggle with **ENTER** between SMALL and LARGE
- SMALL : Small BARCO logo will be displayed if mode is on.
- LARGE : Large (double size) BARCO logo will be displayed if mode is on.
- Background[ON/OFF]    Select background and toggle with **ENTER** between ON and OFF
- ON : BARCO logo will be displayed on a black background. BARCO
- OFF : BARCO logo will be displayed without any background. BARCO
- Orbiting[ON/OFF]        Select orbiting and toggle with **ENTER** between ON and OFF
- ON : the BARCO logo will orbit around its axis.
- OFF : no orbit of the BARCO logo.

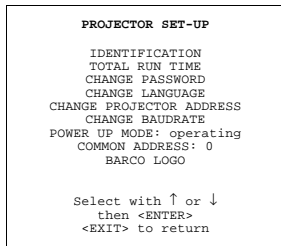

Menu 9-19

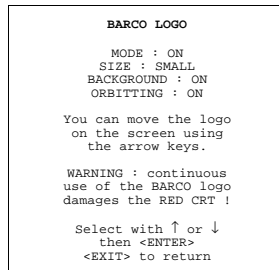

Menu 9-20

---

## 9.4 Memory Management

### Overview

- Starting Up Memory Management
- Copy a Block
- Delete a Block
- Delete All Blocks
- All Settings to Midposition
- R & B Convergence to Midposition
- Green Convergence to Midposition

### 9.4.1 Starting Up Memory Management

#### How to start up the Memory Management?

1. Push the cursor key  $\uparrow$  or  $\downarrow$  to highlight *Memory Management* and press **ENTER** to select. (menu 9-21)

The *Memory Management* menu will be displayed. (menu 9-22)

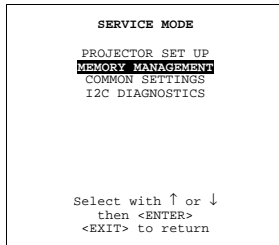

Menu 9-21

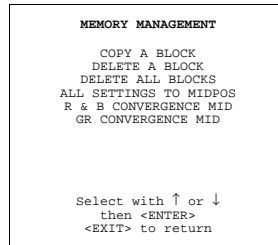

Menu 9-22

### 9.4.2 Copy a Block

#### What can be done?

This will copy the settings of the selected block into the active block.

#### How to Copy a Block?

1. Push the cursor key  $\uparrow$  or  $\downarrow$  to highlight *Copy a Block* and press **ENTER** to select. (menu 9-23)

The *Copy Mode* menu will be displayed.

2. Push the cursor key  $\uparrow$  or  $\downarrow$  to select a block. (menu 9-24)

3. Press **ENTER** to copy the settings of the selected block to the active block you are working on.

**Note:** All current settings will be overwritten with the settings of the block which is copied.

A confirmation screen will be displayed.

4. Press **ENTER** to confirm, press **EXIT** to cancel the saving.

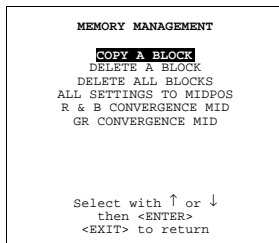

Menu 9-23

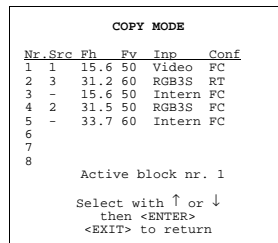

Menu 9-24

### 9.4.3 Delete a Block



This item is password protected.

#### What can be done?

This will delete the selected block.

### How to Delete a Block?

1. Push the cursor key  $\uparrow$  or  $\downarrow$  to highlight *Delete a Block* and press **ENTER** to select. (menu 9-25)  
The *Delete a Block* menu will be displayed. (menu 9-26)
2. Push the cursor key  $\uparrow$  or  $\downarrow$  to select a block.
3. Press **ENTER** to delete the selected block.  
A confirmation screen will be displayed.
4. Press **ENTER** to confirm, press **EXIT** to cancel the deletion.

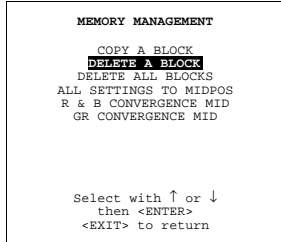

Menu 9-25

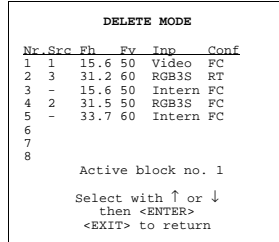

Menu 9-26

### 9.4.4 Delete All Blocks

#### What can be done?

This will delete all blocks.

#### How to Delete All Blocks?

1. Push the cursor key  $\uparrow$  or  $\downarrow$  to highlight *Delete All Blocks*. (menu 9-27)
2. Press **ENTER** to delete all blocks.  
A confirmation screen will be displayed.
3. Press **ENTER** to confirm, press **EXIT** to cancel the deletion.

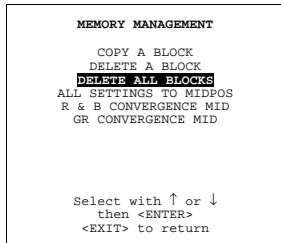

Menu 9-27

### 9.4.5 All Settings to Midposition

#### What can be done?

All adjustment settings (geometry and convergence) can be set to mid position.



This item is password protected.



### How to set All settings to Midposition?

1. Push the cursor key ↑ or ↓ to highlight *All Settings to Midpos.* (menu 9-28)
2. Press **ENTER** to select.  
A confirmation screen will be displayed.
3. Press **ENTER** to confirm, press **EXIT** to cancel the reset.

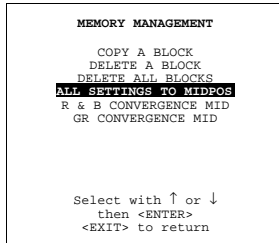

Menu 9-28

### How to Undo All settings to Midposition?

As long as the projector is playing on the same source (= same adjustment block) it is possible to return to the previous settings. *Undo All Settings to Midpos* is displayed in stead off *All Settings to Midpos*.

1. Push the cursor key ↑ or ↓ to highlight *Undo All Settings to Midpos.* (menu 9-29)
2. Press **ENTER** to reset the All settings to the previous settings.

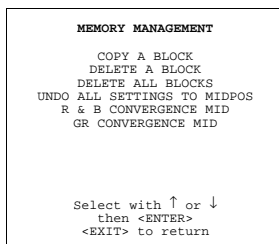

Menu 9-29

## 9.4.6 R & B Convergence to Midposition

### What can be done?

All convergence settings for red and blue are set to midposition.



**This item is password protected.**

### How to set R & B Convergence to Midposition?

1. Push the cursor key ↑ or ↓ to highlight *R&B Convergence Mid.* (menu 9-30)
2. Press **ENTER** to select.  
A confirmation screen will be displayed.
3. Press **ENTER** to confirm, press **EXIT** to cancel the reset.

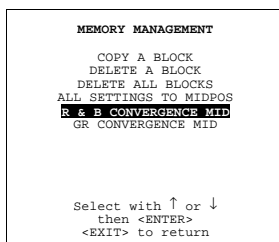

Menu 9-30

### How to Undo Convergence R & B to Midposition?

As long as the projector is playing on the same source (= same adjustment block) it is possible to return to the previous settings. *Undo R&B Convergence to Mid* is displayed in stead off *R&B Convergence to Mid*.

1. Push the cursor key ↑ or ↓ to highlight *Undo R&B Convergence to Mid*. (menu 9-31)
2. Press **ENTER** to reset the All settings to the previous settings.

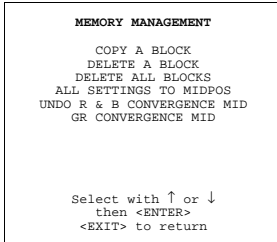

Menu 9-31

### 9.4.7 Green Convergence to Midposition

#### What can be done?

All convergence settings for green are set to midposition.



This item is password protected.

---

#### How to set Green Convergence to Midposition?

1. Push the cursor key ↑ or ↓ to highlight *GR Convergence Mid*. (menu 9-32)
2. Press **ENTER** to select.

A confirmation screen will be displayed.

3. Press **ENTER** to confirm, press **EXIT** to cancel the reset.

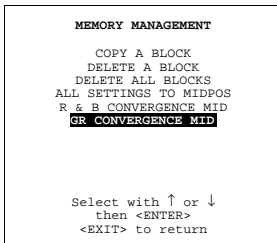

Menu 9-32

#### How to Undo Green Convergence to Midposition?

As long as the projector is playing on the same source (= same adjustment block) it is possible to return to the previous settings. *Undo GR Convergence to Mid* is displayed in stead off *GR Convergence to Mid*.

1. Push the cursor key ↑ or ↓ to highlight *Undo GR Convergence to Mid*. (menu 9-33)
2. Press **ENTER** to reset the All settings to the previous settings.

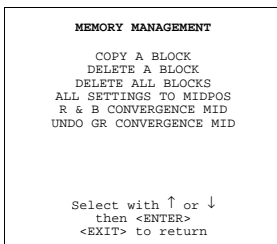

Menu 9-33

## 9.5 Common Settings

### Overview

- Starting Up Common Settings
- G2 Adjustment
- CRT Run In Cycle
- Projector Warm Up
- Memory Banks

### 9.5.1 Starting Up Common Settings

#### How to start up Common Settings?

1. Push the cursor key  $\uparrow$  or  $\downarrow$  to highlight *Common Settings* and press **ENTER** to select. (menu 9-34)

The *Common Settings* menu will be displayed. (menu 9-35)

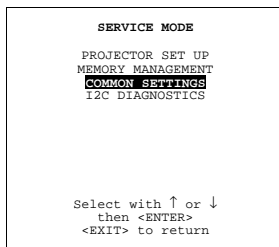

Menu 9-34

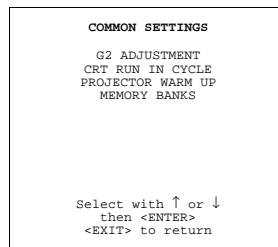

Menu 9-35

### 9.5.2 G2 Adjustment



**G2 adjustment should be performed by BARCO personnel, or BARCO authorized dealers**

#### How to start up G2 adjustment?

1. Push the cursor key  $\uparrow$  or  $\downarrow$  to highlight *G2 Adjustment* and press **ENTER** to select. (menu 9-36)

If you are qualified, press **ENTER** to continue.

If not qualified, press **EXIT** to return to the Common settings menu.

Further description of the G2 adjustment is given in the Installation manual.

Item is password protected.

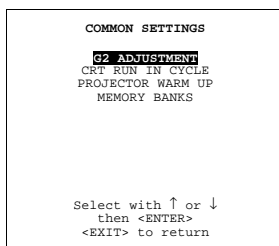

Menu 9-36

### 9.5.3 CRT Run In Cycle

#### When necessary?

Only necessary when a new picture tube is installed.

#### When available?

CRT Run In Cycle can only be activated when one or more memory blocks on an internal # pattern are available.

## 9. Service Mode

If no such a block is available, the projector cannot run CRT Run In Cycle and leaves the adjustment mode. If you still want to run CRT run in cycle, create first a memory block on an internal # pattern and restart CRT Run In Cycle .

### What is done?

A flashing white image (5sec. on, 5 sec. off) is generated for 5 min. on the first internal block. In the next 5 min., the next internal block available will be used to generate the flashing white image.

The image will also be shifted in a vertical way to prevent a CRT burn in.

### How to select CRT Run In Cycle?

1. Push the cursor key  $\uparrow$  or  $\downarrow$  to highlight *CRT Run In Cycle* and press **ENTER** to select. (menu 9-37)  
The *CRT Run In Cycle* menu will be displayed. (menu 9-38)
2. Press **EXIT** to quit the CRT Run In Cycle.

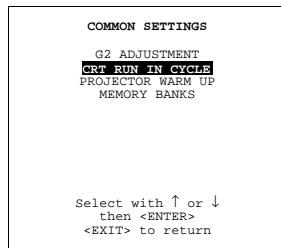

Menu 9-37

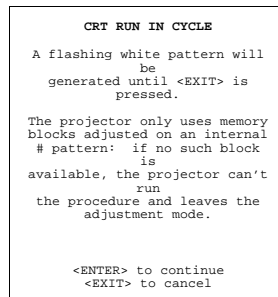

Menu 9-38

## 9.5.4 Projector Warm Up

### What can be done?

When in the ON position (and the CRT run in cycle is OFF), the projector can start up with a warm up period of 20 minutes. During the start up a warm up menu will be displayed. This menu offers the possibility to skip the warm up period anyway by pressing the EXIT key and offers the possibility to adjust the horizontal and vertical amplitude of this white image with the control disc. During this warm up period, a full white image is shifted on the CRT faceplate to avoid a burn in. Every 30 seconds a text box will be displayed on another place on the screen with the remaining time to go. When EXIT is pressed during this warm up period, the warm up menu will be redisplayed with the remaining time indication. Press another time EXIT to interrupt the warm up cycle. When the warm up option is OFF, when switching on the projector, it starts immediately with the projection of the selected source.

### How to select

1. Push the cursor key  $\uparrow$  or  $\downarrow$  to highlight *Projector Warm Up*. (menu 9-39)
2. Press **ENTER** to select.  
The projector warm up menu will be displayed. (menu 9-40)
3. Press **ENTER** to toggle the ON/OFF option.

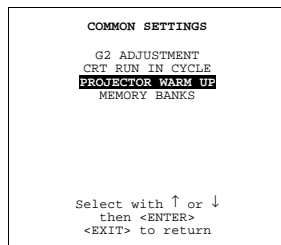

Menu 9-39

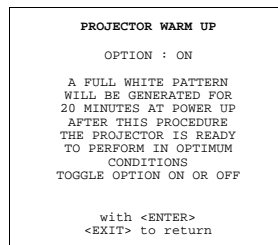

Menu 9-40

## 9.5.5 Memory Banks

### What can be done?

The user has the possibility to create 8 different memory banks (formats) for each source. But, the maximum allowed quantity of memory banks for all sources together is 32. The option to create different memory banks for the same source can be switched ON or OFF.

### How to select

1. Push the cursor key ↑ or ↓ to highlight *Memory Banks*. (menu 9-41)
2. Press **ENTER** to toggle between *ON* and *OFF*.

ON	different memory banks available
OFF	only one memory bank available.

If different memory banks are available for a source and the memory bank option is toggled to OFF, only the first memory bank will be used to display the source.

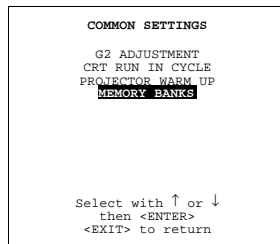

Menu 9-41

### How to create a new memory blank

1. Select your source. The projector selects the last used memory bank.
2. Press **ENTER**.
3. Push the corresponding digit (between 1 and 8) of a non existing memory bank. (The memory banks can be created in random order, e.g. first creating bank 5 and later bank 2.)
4. Make the necessary adjustments. When leaving the source, the new created memory bank will be saved for later use.

When source 1, video 15.6 kHz /60Hz is create on bank 4 and the vertical frequency changes to 50Hz, the projector will create a new block (due to the vertical frequency change) with the same bank number 4.

### How to recall a specific memory bank for the actual source?

When the memory bank option is ON and a source is selected, this source will be displayed with the last used memory bank settings. An on-screen menu will give a indication of the memory bank number used. To switch to another memory bank :

1. Press **ENTER** to select the next memory bank in increasing order.  
Or,  
Enter the number of the desired memory bank with the digit keys.

## 9.6 I2C Diagnostics

### What can be seen?

The I2C diagnostics menu gives an overview of the I2C failures inside the projector.

To scroll through the failure list, push the cursor key ↑ or ↓ . The I2C address, IC number and module name will be given in I2C diagnostic menu. When no errors are detected, the following message will appear on the screen : "No errors on i2c-bus detected".

### How to select

1. Push the cursor key ↑ or ↓ to highlight *I<sup>2</sup>C Diagnostics*. (menu 9-42)
2. Press **ENTER** to display the diagnostic menu. (menu 9-43)

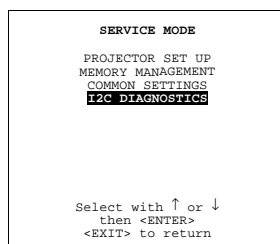

Menu 9-42

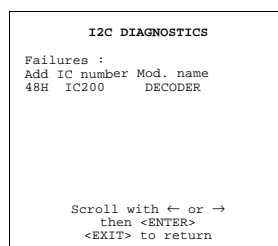

Menu 9-43



# 10. PROGRAMMABLE FUNCTION KEYS

## 10.1 Programming a Function Keys

### What can be done with these keys?

The five function keys on top of the remote control can be programmed as short cut keys (quick access) to almost any adjustment function. See list further in this chapter.

### How can a Function key be programmed?

A function key can only be programmed when in the service menus.

1. Scroll through the menus until the desired function is on the menu.
2. Select this function by pushing the cursor keys up or down.
3. Press the desired function key for this function.

The following message : "Programming Function Key Fx" will be displayed.

The message will disappear automatically and the function key is programmed.

4. Leave the adjustment mode by pressing **ADJUST**.
5. The function key is available in the operational mode.

### Example programming horizontal phase on key F4

1. Press **ADJUST** to enter the main menu. (menu 10-1)
2. Push the cursor key  $\uparrow$  or  $\downarrow$  to select *Service mode*.
3. Press **ENTER** to go into the adjustment menus.  
A warning will be displayed. (menu 10-2)
4. If qualified, press **ENTER** otherwise press **EXIT** and call for technical assistance.
5. Select Random Access by pushing the cursor keys  $\uparrow$  or  $\downarrow$ .
6. Press **ENTER** to display the Random Access mode menu. (menu 10-3)
7. Push the cursor key  $\uparrow$  or  $\downarrow$  to select Geometry.
8. Press **ENTER** to display the Geometry menu. (menu 10-4)
9. Push the cursor key  $\uparrow$  or  $\downarrow$  to select *H PHASE*. (menu 10-5)
10. Press **F4** to program this key.
11. Press **ADJUST** to return to operational mode.

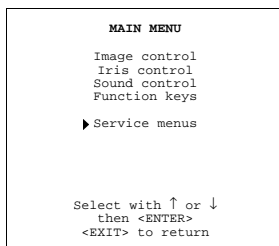

Menu 10-1

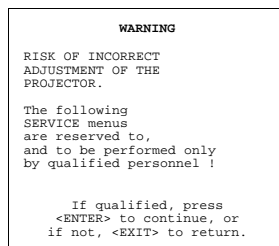

Menu 10-2

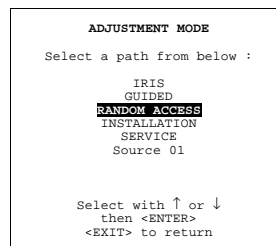

Menu 10-3

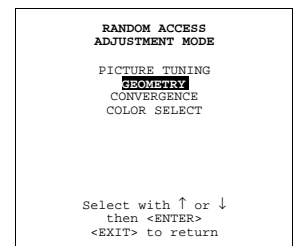

Menu 10-4

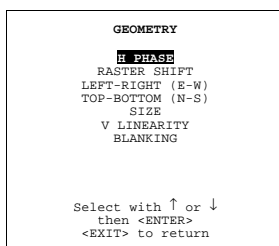

Menu 10-5

## 10.2 Different function which can be programmed.

---

### Overview

- Line Multiplier on/off
- Motion Processing on/off
- Time Base Correction on/off
- LIMO Output Mode
- LIMO Noise Reduction
- LIMO Contrast Enhancement
- Line Doubler on/off
- Color Balance
- Decoding EBU/IRE
- Sync Fast/Slow
- RGB Peaking
- Green Convergence
- Convergence Red on Green
- Convergence Blue on Green
- Horizontal Phase
- H & V Size
- Vertical Linearity
- Green Horizontal Coarse Shift
- Green Vertical Coarse Shift
- Red Vertical Coarse Shift
- Vertical Centerline Bow
- Vertical Centerline Skew
- Right Bow
- Right Keystone
- Left Bow
- Left Keystone
- L-R Seagull Correction
- Horizontal Centerline Bow
- Horizontal Centerline Skew
- Top Bow
- Top Keystone
- Bottom Keystone
- T-B Seagull Correction
- IRIS Touch-Up
- IRIS Quick Autopicture
- IRIS Full Autopicture
- IRIS Align Source
- IRIS Align Source From Mid
- IRIS Touch-Up All Sources
- IRIS Align All Sources
- IRIS Align All Sources From Mid
- Blanking Top
- Blanking Bottom
- Blanking Left
- Blanking Right

### Factory predefined functions

- F1 = IRIS Touch-Up
- F2 = Convergence Red on Green
- F3 = Convergence Blue on Green
- F4 = H & V Size
- F5 = Color Balance



# 11. MESSAGES, WARNINGS AND FAILURES

## Overview

- Messages
- Warnings
- Failures

## 11.1 Messages

### Messages

INPUT 01 RGB2 Fh=064kHz Fv=060Hz	When selecting a new source, following information about this source will be displayed on the screen: Source number, horizontal and vertical frequencies of the displayed source.
SOURCE 01 RGB2	Announcement of the selected source.
enter password XXXX	Message to enter your password, password contains 4 digits.
WRONG PASSWORD !!!	Message when the entered password is wrong
TEXT on SOURCE 01 RGB2 xxxkHz xxHz	These messages will be displayed on the screen when pushing the TEXT key.
TEXT On	TEXT On: the 'bar scale indication' will be enabled during the change of an analog control in the 'operational mode' + all warnings and failures will be displayed.
TEXT Off	Text OF: the 'bar scale indication' will be disabled during the change of an analog control in the 'operational mode' + all warnings and failures will not be displayed.
PROJECTOR ADDRESS: 003	Indication of the projector address when activating the 'ADDRESS' button on the RCU with a pencil or other small object.

## 11.2 Warnings

### Warnings

WARNING: Input not available	When using the projector with the RCVDS, this warning will be displayed when selecting an input slot of an RCVDS where the input board is missing.
WARNING: Source not available	The input is a valid input but the source is not connected to the input terminals or the input source is switched off.
WARNING: Invalid key intro	When a wrong key is pressed on the RCU.
WARNING: End of adjust range	End of adjustment range.
WARNING: Input no longer available	The input source is no longer available.
WARNING: RCVDS not available	The input source selector is not available.
WARNING: invalid frequency input	The entered frequency or applied frequency of the source is out of the projector's range.
WARNING: Option not installed !	Option not installed. e.g. Video selected but no decoder installed.

### 11.3 Failures

---

#### Failures

FAILURE I2C error addr.: 7FH3	Hardware failure. Call a qualified service technician for repair.
FAILURE short circuit on I2C bus	Hardware failure. Call a qualified service technician for repair.
FAILURE RCVDS communication error	Serial communication error between the RCVDS and the projector.
FAILURE invalid input	Input not valid
FAILURE PC communication error	Error in the communication between the projector and the PC.
FAN FAILED Projector will switch off	Projector switched off due to a fan fail.

## A. SOURCE NUMBERS 81 — 86 AND 91 — 96

### A.1 Projector without any 800 peripheral connected

#### Overview

The source numbers 81 - 86 and 91 - 96 do not correspond to physical inputs. An additional adjustment file can be created for these source numbers. This file can contain different settings. The relationship between sources 1 - 6 and 91 - 96 or between 1 - 6 and 81 - 86 is shown in the diagram below.

Source input 1	source number 1	file A
	source number 81	file A'
	source number 91	file A''
Source input 2	source number 2	file B
	source number 82	file B'
	source number 92	file B''
Source input 3	source number 3	file C
	source number 83	file C'
	source number 93	file C''
	...	
Source input 6	source number 6	file F
	source number 86	file F'
	source number 96	file F''

#### How to create a second source?

Follow the steps below to create a second or a third file for sources 1 to 6 :

1. Select the source between 1 and 6.
2. Select the corresponding source number between 81 and 86 or 91 and 96 with the digit keys on the RCU.
3. Enter the adjustment mode and load a corresponding file. Edit this file if necessary.
4. Save the file and exit the adjustment mode.

### A.2 Projector with a 800 peripheral connected

#### Overview

- Source numbers 91 — 96
- Source numbers 81 — 86

#### A.2.1 Source numbers 91 — 96

#### Overview

The source numbers 91 - 99 do not correspond to physical inputs. An additional adjustment file can be created for these source numbers (source numbers of the 800 peripheral). This file can contain different settings. The relationship between sources 1 - 9 of the 800 peripheral and 91 - 99 is shown in the diagram below.

source input 1	source input 1	file A
	source input 91	file A'
source input 2	source input 2	file B
	source input 92	file B'

## A. Source Numbers 81 — 86 and 91 — 96

---

source input 3	source input 3	file C
	source input 93	file C'
	...	
source input 6	source input 6	file F
	source input 96	file F'

Follow the same procedure as for a projector without a 800 peripheral connected.

### A.2.2 Source numbers 81 — 86

#### Overview

Only valid if no input module is connected to slot 81 - 86 of a RCVDS05. The source numbers 81 - 86 correspond to the physical inputs 1 - 6 of the projector. e.g. When slot 1 of the projector has to be selected, key in source number 81. The relationship between the sources of slot 1 - 6 of the projector with 800 peripheral is shown in the table below.

source of slot 1	source number 81
source of slot 2	source number 82
source of slot 3	source number 83
source of slot 4	source number 84
source of slot 5	source number 85
source of slot 6	source number 86

---

# GLOSSARY

**Chrominance**

The color component of a video signal that includes information about tint and saturation.

**Common address**

Default address. Projector will always execute the command coming from a RCU programmed with that common address.

**CTI**

Color transient improvement. To improve the transition from one color to another.

**Interlaced**

Short for interlaced scanning. Also called line interlace. A system of video scanning whereby the odd- and even-numbered lines of a picture are transmitted consecutively as two separate interleaved fields. Interlace is a form of compression.

**LTI**

Luminance transient improvement.

**Luminance**

The component of a video signal that includes information about its brightness.

**Progressive**

Short for progressive scanning. A system of video scanning whereby lines of a picture are transmitted consecutively, such as in the computer world

**Projector address**

Address installed in the projector to be individually controlled.

**RS232**

A standard, single-ended (unbalanced) interconnection scheme for serial data communications.



# INDEX

## A

- AC Power 9
  - Power Cord 9
    - Connection 9
    - Power Voltage 9
    - Switching ON/OFF 9
- Address 27–28
  - Program 28
    - RCU 28
  - Projector 27
- Adjustment 45, 49
  - menus 45
  - Random Access 49
    - Introduction 49
- Adjustment mode 31–32
  - Adjust 32
  - Start up 31
    - Via the local keypad 31
    - Via the RCU 31
- Advanced Settings 61–62
  - Start up 62

## B

- Barco Logo 89
- Battery 21
  - Installation 21
  - Replacement 21
- Baudrate 87
  - Change 87
- Blanking 79
  - Adjustments 79
- Block 91–92
  - Copy 91
  - Delete 91–92
    - All 92

## C

- Clamp Gating 63
- Cleaning 7
- Color Adjust 38
- Color Balance 53–55
  - Custom black balance 55
  - Custom white balance 54
  - Fixed 54
    - Select 53
- Color temperature 38
- Common Address 88
- Common Settings 95
  - Start up 95
- Communication Port 20
  - Peripherals 20
- Component analog 17–18
  - With composite sync 17
    - Source connections 17
  - With Tri level composite sync 18
    - Source connections 18
- Composite video 12
  - Source connections 12
- Connection 19
  - RS232 19
- Contrast Enhancement 38, 60
- Convergence 80–81
  - Adjustment 81
  - Start up 80
- Coring 64
- CRT Run In Cycle 95
- CTI 66

## D

- Decoding 55

## F

- Factory Preset Frequencies 51
- Factory presets 67
- Failures 101–102
- FCC Statement 5
- Fire Hazard 6
- Format Select 39–40
  - Add name 39
  - Selecting 39
  - Storing settings 40
- Function keys 99–100
  - Possible actions 100
  - Programming 99
- Function Keys 43

## G

- G2 Adjustment 95
- Geometry 68, 70, 73, 78
  - Bow & keystone Adjustment 73
    - Horizontal Centerline 73
    - Left-right adjustment 70
    - Seagull correction 70, 73
    - Side Adjustment 70
  - Start up 68
  - Top-Bottom adjustment 73
  - Vertical Centerline 70
  - Vertical linearity 78
- Getting Started 21

## H

- Horizontal Phase 68
  - Adjustment 68

## I

- I2C Diagnostics 97
- Identification 85
- Illumination 7
- Image Control 33–35, 38–40
  - Color Adjust 38
  - Color temperature 38
  - Format Select 39–40
    - Add name 39
    - Selecting 39
    - Storing settings 40
  - Line Multiplier 34–35
    - Changing setting 34
    - Multiplier mode 35
  - Start up 34
- Input 11
  - Locations 11
- Input selection 28
  - Via local keypad 28
  - Via RCU 28
- Installation 7
- Installation Instructions 5
- Internal # Pattern 51
- IRIS Auto Converge 41
- IRIS Control 40–41
  - Start up 41
- IRIS Full Alignment 42
- IRIS Touch Up 41

**L**

- Language 86
  - Change 86
- Limo Pro 64–66
  - Coring 64
  - CTI 66
  - LTI 65
  - Options 64
    - Start up 64
- Limo Pro Options 64
- Line multiplier 67
  - Advanced settings 67
  - Factory presets 67
- Line Multiplier 34–35, 57–63
  - Advanced Settings 61–63
    - Clamp Gating 63
    - Luminance Delay 62
    - Start up 62
    - Time Base Correction 62
    - Vertical Sync Reference 63
  - Changing setting 34
  - Contrast Enhancement 60
  - Motion Processing 58
  - Multiplier mode 35
  - Noise Reduction 60
  - Output Mode 59
  - settings 57–58
    - Start up 57
    - Switching on/off 58
  - Split Screen 61
  - Video Equalizing 59
- LTI 65
- Luminance Delay 62

**M**

- Main Menu 33
  - Overview 33
- Memory Banks 96
  - Select 96
- Memory Management 90–91
  - Start Up 91
- Messages 101
- Midposition 92–94
  - All settings 92
  - Convergence Green 94
  - Convergence R & B 93
- Motion Processing 36, 58
  - On/Off 36, 58

**N**

- Noise Reduction 37, 60
- Notice on Safety 5

**O**

- Operational Mode 25
  - Start up 25
- Output Mode 59
- Owner's Record 5

**P**

- Password 46, 86
  - Change 86
  - Protection 46
- Peaking 56
- Peripherals 20
  - Communication 20
  - Port 20
- Picture Controls 28
  - Via local keypad 28
  - Via RCU 28

- Picture tuning 55–57
  - Decoding 55
  - Line Multiplier 57
  - Peaking 56
  - Port 2 Video/S-Video 56
  - Sync mode 55
- Picture Tuning 52–55
  - Color Balance 53–55
    - Custom black balance 55
    - Custom white balance 54
    - Fixed 54
    - Select 53
  - Start up 53
- Port 2 56
  - Configuration (Optional) 56
  - Video/S-Video 56
- Power Up 88
  - Operating/Stand By 88
- Projector 25–28, 85, 87
  - Address 27, 87
    - Change 87
    - Controlling 27
  - Controlling 28
    - Input selection 28
    - Picture Controls 28
  - Set-Up 85
    - Start up 85
  - Switch off 26
  - Switch on 25
  - Projector Set up 84
  - Projector Warm Up 96

**R**

- Random Access 49–50, 52–53, 68
  - Geometry 68
  - Introduction 49
  - Overview 50
  - Picture Tuning 52–53
    - Color Balance 53
  - Selection menu 52
  - Start up 49
- Raster Shift 69
  - Adjustment 69
- RCU 21–23, 26
  - Battery 21
  - Terminology 22–23
  - Overview 23
  - Use 26
- Repacking 7
- RGB analog 15–16
  - With composite sync 15
    - Source connections 15
  - With Tri level composite sync 16
    - Source connections 16
- RS232 Connection 19

**S**

- S-Video 13
  - Source connections 13
- Safety 6
- Safety Indication 5
- Safety Instructions 5
- Safety Warning 5
- Service Menus 43
- Service Mode 83–84, 90
  - Introduction 83
  - Memory Management 90
  - Overview 84
  - Projector Set up 84
  - Start up 83
- Servicing 7
- Setup Pattern 51
  - Selecting 51



Size Adjustment 76  
Sound Control 42  
Source connections 12–13, 15–18  
    Component source 17–18  
        With composite sync 17  
        With Tri level composite sync 18  
    Composite video 12  
    RGB analog 15–16  
        With composite sync 15  
        With Tri level composite sync 16  
    S-Video 13  
Source Connections 11  
Source numbers 103–104  
    with 800 peripheral 103–104  
        source numbers 81 — 86 104  
        source numbers 91 — 96 103  
    without 800 peripheral 103  
Split Screen 61  
    On/Off 61  
Stand By Mode 25  
    Start up 25  
Stationary Image Warning 26  
Switch off 26

Switch on 25  
Switching ON/OFF 9  
Sync mode 55  
    Fast/Slow 55

## T

Time Base Correction 62  
Total Run Time 85  
Trigger output 20

## V

Vertical Sync Reference 63  
Video Equalizing 36, 59

## W

Warm up period 25  
    Interrupt 25  
Warnings 101



## Revision Sheet

To:

► **Barco nv Home Cinema/Documentation**  
Noordlaan 5, B-8520 Kuurne  
Phone: +32 56.36.84.30, Fax: +32 56.36.88.62  
E-mail: antoon.dejaegher@barco.com, Web: www.homecinema.barco.com

From: \_\_\_\_\_

Date: \_\_\_\_\_

Please correct the following points in this documentation (**R5976584/00**):

**page**

**wrong**

**correct**

## Free Manuals Download Website

<http://myh66.com>

<http://usermanuals.us>

<http://www.somanuals.com>

<http://www.4manuals.cc>

<http://www.manual-lib.com>

<http://www.404manual.com>

<http://www.luxmanual.com>

<http://aubethermostatmanual.com>

Golf course search by state

<http://golfingnear.com>

Email search by domain

<http://emailbydomain.com>

Auto manuals search

<http://auto.somanuals.com>

TV manuals search

<http://tv.somanuals.com>