

## INSTRUCTION SET

### Arithmetic Operations

Instruction	Operation	bytes	OSC Periods
ADD A,#source	add source to A	1,2	12
ADD A,#data		2	12
ADDC A,#data	add with carry	1,2	12
ADDC A,#data		2	12
SUBB A,#source	subtract from A with borrow	1,2	12
SUBB A,#data		2	12
INC A	increment	1	12
INC source		1,2	12
INC DPTR *		1	24
DEC A	decrement	1	12
DEC source		1,2	12
MUL AB	multiply A by B	1	48
DIV AB	divide A by B	1	48
DA A	decimal adjust	1	12

### Legend

Rn	register addressing using R0-R7	bytes	OSC Periods
direct	8bit internal address (00h-FFh)		
@Ri	indirect addressing using R0 or R1		
source	any of [Rn, direct, @Ri]		
dest	any of [Rn, direct, @Ri]		
#data	8bit constant included in instruction		
#data16	16bit constant included in instruction		
bit	8bit direct address of bit		
rel	signed 8bit offset		
addr11	11bit address in current 2K page		
addr16	16bit address		

\* INC DPTR increments the 24bit value DPP/DPH/DPL

### Logical Operations

Instruction	Operation	bytes	OSC Periods
ANL A,#source	logical AND	1,2	12
ANL A,#data		2	12
ANL direct,A		2	12
ANL direct,#data		3	24
ORL A,#source	logical OR	1,2	12
ORL A,#data		2	12
ORL direct,A		2	12
ORL direct,#data		3	24
XRL A,#source	logical XOR	1,2	12
XRL A,#data		2	12
XRL direct,A		2	12
XRL direct,#data		3	24
CLR A	clear A to zero	1	12
CPL A	complement A	1	12
RL A	rotate A left	1	12
RLC A	...through C	1	12
RR A	rotate A right	1	12
RRC A	...through C	1	12
SWAP A	swap nibbles	1	12

### Data Transfer Operations

Instruction	Operation	bytes	OSC Periods
MOV A,#source	move source to destination	1,2	12
MOV A,#data		2	12
MOV dest,A		1,2	12
MOV dest,source		1,2,3	24
MOV dest,#data		2,3	12,24
MOV DPTR,#data16		3	24
MOVC A,@A+DPTR	move from code memory	1	24
MOVC A,@A+PC		1	24
MOVB A,@Ri	move to/from data memory	1	24
MOVB @Ri,A		1	24
MOVB @DPTR,A		1	24
PUSH direct	push onto stack	2	24
POP direct	pop from stack	2	24
XCH A,#source	exchange bytes	1,2	12
XCHD A,@Ri	exchg low digits	1	12

### Program Branching

Instruction	Operation	bytes	OSC Periods
ACALL addr11	call subroutine	2	24
LCALL addr16		3	24
RET	return from sub.	1	24
RETI	return from int.	1	24
AJMP addr11	jump	2	24
LJMP addr16		3	24
SJMP rel		2	24
JMP @A+DPTR		1	24
JZ rel	jump if A = 0	2	24
JNZ rel	jump if A not 0	2	24
CJNE A,direct,rel	compare and jump if not equal	3	24
CJNE A,#data,rel		3	24
CJNE Rn,#data,rel		3	24
CJNE @Ri,#data,rel		3	24
DJNZ Rn,rel	decrement and jump if not zero	2	24
DJNZ direct,rel		3	24
NOP	no operation	1	12

### Boolean Variable Manipulation

Instruction	Operation	bytes	OSC Periods
CLR C	clear bit to zero	1	12
CLR bit		2	12
SETB C	set bit to one	1	12
SETB bit		2	12
CPL C	complement bit	1	12
CPL bit		2	12
ANL C,bit	AND bit with C	2	24
ANL C,#data	...NOTbit with C	2	24
ORL C,bit	OR bit with C	2	24
ORL C,#data	...NOTbit with C	2	24
MOV C,bit	move bit to bit	2	12
MOV bit,C		2	24
JC rel	jump if C set	2	24
JNC rel	jmp if C not set	2	24
JB bit,rel	jump if bit set	3	24
JNB bit,rel	jmp if bit not set	3	24
JBC bit,rel	jmp&clear if set	3	24

## ASSEMBLER DIRECTIVES

EQU	define symbol	DW	store word values in program memory
DATA	define internal memory symbol	ORG	set segment location counter
IDATA	define indirect addressing symbol	END	end of assembly source file
XDATA	define external memory symbol	CSEG	select program memory space
BIT	define internal bit memory symbol	XSEG	select external data memory space
CODE	define program memory symbol	DSEG	select internal data memory space
DS	reserve bytes of data memory	ISEG	select indirectly addressed internal data memory space
DBIT	reserve bits of bit memory	BSEG	select bit addressable memory space
DB	store byte values in program memory		

## PIN FUNCTIONS

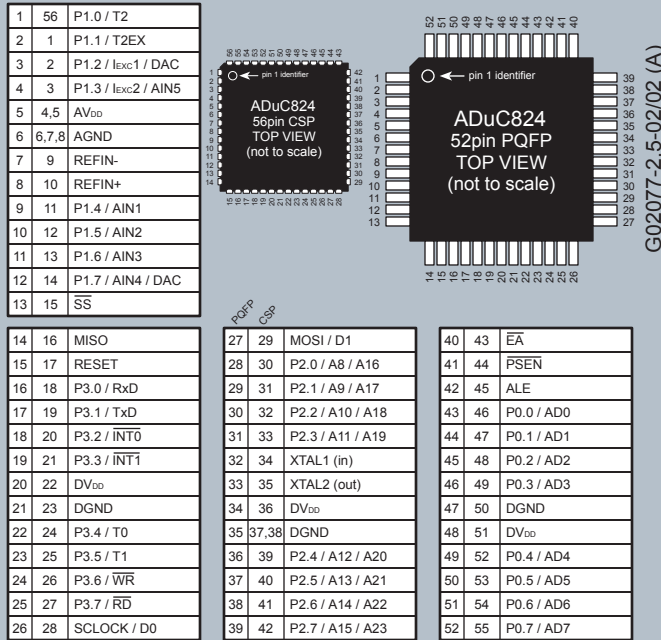

## PROGRAM MEMORY SPACE (read only)

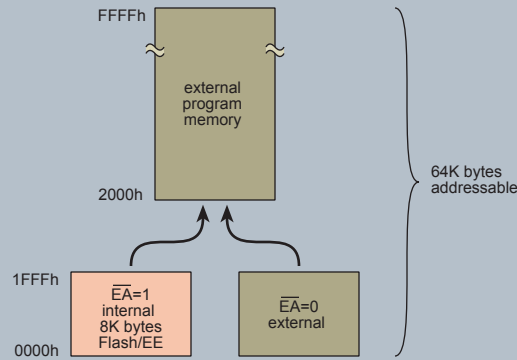

## INTERRUPT VECTOR ADDRESSES

Interrupt Bit	Interrupt Name	Vector Address	Priority within Level
PSMCON.5	Power Supply Monitor Interrupt	43h	1
WDS	WatchDog Timer Interrupt	5Bh	2
IE0	External Interrupt 0	03h	3
RDY0/RDY1	End of ADC Conversion Interrupt	33h	4
TF0	Timer0 Overflow Interrupt	0Bh	5
IE1	External Interrupt 1	13h	6
TF1	Timer1 Overflow Interrupt	1Bh	7
ISPI	SPI Interrupt	3Bh	8
RI/TI	UART Interrupt	23h	9
TF2/EXF2	Timer2 Interrupt	2Bh	10
TIMECON.2	Time Interval Counter Interrupt	53h	11

# MicroConverter® Quick Reference Guide

a "Data Acquisition System on a Chip"

the ADuC824 is: ADC: 24bit  $\Sigma\Delta$  with programmable gain, plus 16bit  $\Sigma\Delta$  auxiliary ADC

DAC: 12bit, 15 $\mu$ s, voltage output, rail-to-rail <1LSB DNL

EEPROM: 8K bytes Flash/EE program memory  
640 bytes Flash/EE data memory

microcontroller: industry standard 8052  
32 I/O lines, programmable PLL clock (98KHz to 12MHz from 32KHz crystal)

other on-chip features: calibrated temperature sensor, power supply monitor, watchdog timer, flexible serial interface ports, voltage reference, time interval counter

## FUNCTIONAL BLOCK DIAGRAM

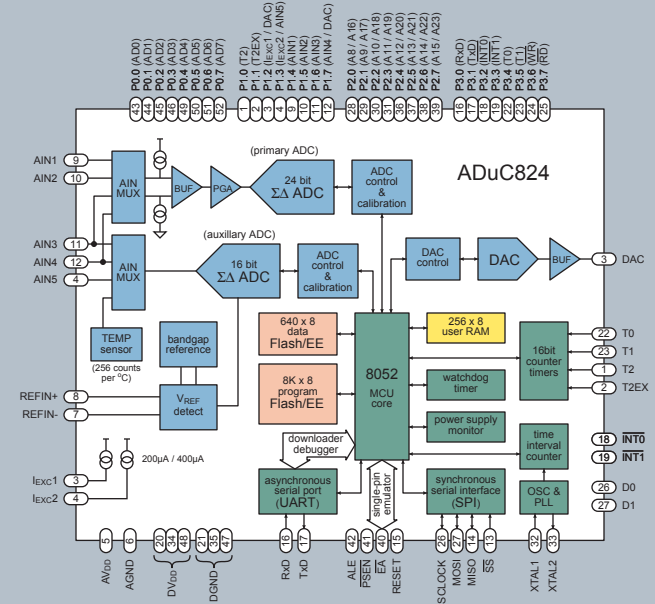

PRINTED IN U.S.A.



## Free Manuals Download Website

<http://myh66.com>

<http://usermanuals.us>

<http://www.somanuals.com>

<http://www.4manuals.cc>

<http://www.manual-lib.com>

<http://www.404manual.com>

<http://www.luxmanual.com>

<http://aubethermostatmanual.com>

Golf course search by state

<http://golfingnear.com>

Email search by domain

<http://emailbydomain.com>

Auto manuals search

<http://auto.somanuals.com>

TV manuals search

<http://tv.somanuals.com>