

6-Year Limited Tank/ 6-Year Limited Parts Warranty*

PRESSURIZED COMBUSTION SYSTEM

- Exclusive and patented pressurized combustion chamber with an advanced air intake blower delivers superior efficiency. Much like a turbocharger, the blower distributes an optimum air-to-gas mixture pushing exhaust gases through the highly restricted flue baffle. The end result is the most efficient atmospheric gas product on the market with a .70 Energy Factor (EF).

INSTALLATION FRIENDLY

- Allows for easy replacement of standard atmospheric vent heaters.
- Easily connects to existing B-vent.

FAN-ASSISTED, CATEGORY 1 APPLIANCE

24V ELECTRONIC CONTROLS

- Tighter differential for more consistent hot water delivery.

ELECTRONIC IGNITION

- The durable hot surface ignitor eliminates pilot relight issues (no standing pilot).

LCD USER INTERFACE

- Easy-to-read, eye level display. Simple temperature settings and adjustments. Service diagnostics are in plain text.

POWERED ANODE ROD

- Powered anodes are non-sacrificial, so they do not deplete over time. Additionally, they provide exceptional performance in all water conditions.

MEETS ENERGY-EFFICIENCY REQUIREMENTS FOR MOST GAS UTILITY REBATE PROGRAMS, AND MEETS ENERGY STAR® REQUIREMENTS.

DURABLE TAMPER-RESISTANT BRASS DRAIN VALVE

DIFFUSER DIP TUBE

- Helps reduce lime and sediment buildup, maximizes hot water output.
- Made from long-lasting PEX cross-linked polymer.

GREEN CHOICE® GAS BURNER

- Patented "Eco-Friendly" Green Choice® gas burner reduces NOx emissions by 33% compared to standard burners and meets low NOx requirements of less than 40ng/j.

CSA CERTIFIED AND ASME RATED T&P RELIEF VALVE

CODE COMPLIANCE: UBC, CEC, SBCC, CABO, HUD, BOCA NATIONAL CODES, CURRENT EDITION ASHRAE/IESNA 90.1 AND 2004 NAECA STANDARDS

DESIGN-CERTIFIED BY CSA INTERNATIONAL

- According to ANSI Z21.10.1 - 4.1 CSA Standards governing storage-type water heaters.



**PCG6240T403NOV and
PCG6250T403NOV**



*For complete warranty information consult the written warranty of American Water Heaters found at www.americanwaterheater.com, or call (800) 456-9805.

MODEL NUMBER	GALLON CAPACITY	ENERGY FACTOR	BTU INPUT PER HOUR	RECOVERY AT 90° RISE	FIRST HOUR RATING	FOAM THICKNESS (INCHES)	DIMENSIONS IN INCHES						DRAFT HOOD OUTLET	SHIPPING WEIGHT (LBS)
							A	B	C	D	E	F		
PCG6240T403NOV	40	.70	40,000	43	70 GPH	2	20	61-3/4	58	51-1/2	23-1/4	25	3 or 4	157
PCG6250T403NOV	50	.70	40,000	43	81 GPH	2	22	60-5/8	57-1/8	50-1/2	25-1/4	27	3 or 4	171

All dimension in inches.
 Recovery capacity based on actual performance tests.
 Water Connections – 3/4" on all models.
 Not available in LP gas (Propane).
 Certified for installations up to 5500 ft. elevations.

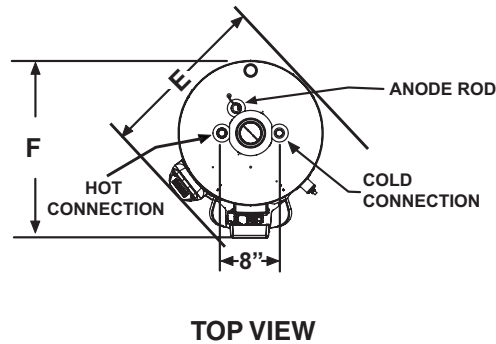
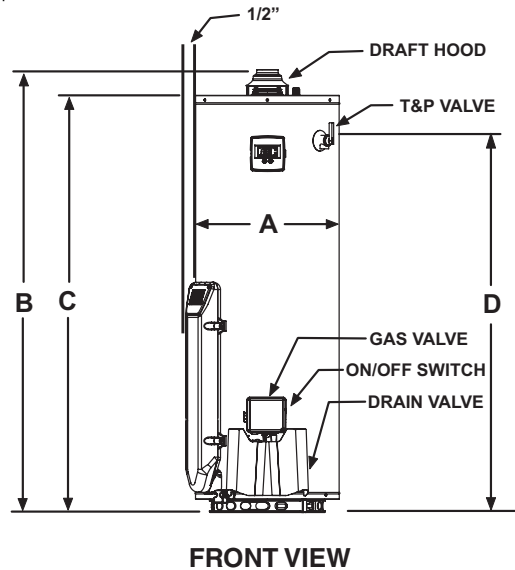

Maximum Hydrostatic Working Pressure: 150 PSI

Flammable Vapor Ignition Resistant Water Heaters

This FVIR design meets the American National Standards Institute standards (ANSI Z21.10.1 - 4.1 CSA Standards) that deal with the accidental or unintended ignition of flammable vapors outside the water heater, such as those emitted by gasoline.

Residential Gas High Efficiency Water Heater Specification

Residential gas water heater(s) shall be models _____ as manufactured by American Water Heaters, or an approved equal, and shall have a _____-year tank warranty and a _____-year parts warranty, when installed in a residential application. Heater(s) shall have a storage capacity of _____ gallons and shall have a rated input of _____ BTUs, and shall be designed, tested and listed with CSA International in accordance with the latest edition of ANSI Z21.10.1 - CSA4.1 standard. Heaters shall meet or exceed the Federal Energy Efficiency Standards effective January 20, 2004, according to the National Appliance Energy Conservation Act (NAECA) of 1992. The interior of the storage tank shall be lined with a Fused Ceramic Shield lining, fused to the tank at 1600° F, forming a corrosion-resistant lining; polymer linings are not acceptable. Each tank shall be furnished with an internal powered anode for cathodic protection. The unit must be equipped with a combination gas control thermostat and non-reset type ECO. A corrosion-resistant drain valve shall be provided on the front of each unit. The tank shall be totally encased in a steel jacket, painted and insulated with a non-CFC foam to reduce standby heat loss. The tank must be design certified for 300 PSI test pressure and 150 working pressure.

Distributed By:

Order Entry and Sales
 500 Princeton Road (FEDEX, UPS)
 Johnson City, TN 37601-2030
 P.O. Box 4808 (Mailing)
 Johnson City, TN 37602-4808
 (800) 937-1037
 FAX (800) 581-7224

Warranty and Service
 500 Princeton Road (FEDEX, UPS)
 Johnson City, TN 37601-2030
 P.O. Box 1597 (Mailing)
 Johnson City, TN 37605-1597
 (800) 456-9805
 FAX (800) 999-5210

NRGSS01010

Free Manuals Download Website

<http://myh66.com>

<http://usermanuals.us>

<http://www.somanuals.com>

<http://www.4manuals.cc>

<http://www.manual-lib.com>

<http://www.404manual.com>

<http://www.luxmanual.com>

<http://aubethermostatmanual.com>

Golf course search by state

<http://golfingnear.com>

Email search by domain

<http://emailbydomain.com>

Auto manuals search

<http://auto.somanuals.com>

TV manuals search

<http://tv.somanuals.com>