

American **AUDIO**

V3000 & V2000_{MK II}

PROFESSIONAL POWER AMPLIFIERS

User Instructions

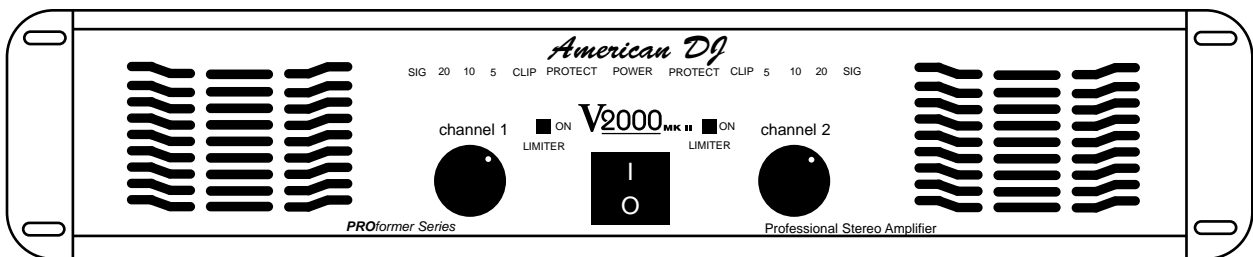
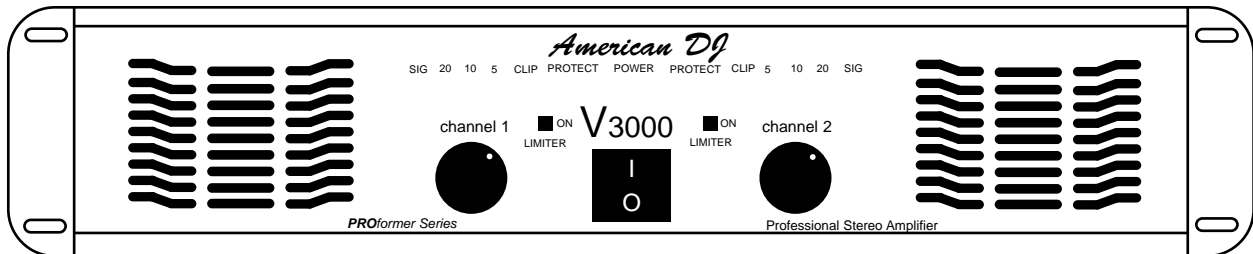

**professional products designed for
installations and the working dj.**

V3000 / V2000 MK II Power Amplifier Instructions
©American AUDIO Los Angeles, CA 90058 USA

Contents:

Front Panel.....	3
Rear Panel.....	3
Application Diagrams.....	3,4,5
Operating Voltage.....	5
Inputs.....	6
Outputs.....	6
Limiter.....	6
Low-Cut Filter.....	6
Gain Controls.....	7
LED Indicators.....	7
Protect Indicators.....	7
Protection.....	7
Specifications.....	8



CAUTION

**Do not open -
risk of electric shock**



CAUTION: TO REDUCE THE RISK OF ELECTRIC SHOCK, DO NOT REMOVE THE COVER RACK. THERE ARE NO USER SERVICEABLE PARTS INSIDE. REFER SERVICE TO YOUR AUTHORIZED AMERICAN DJ AUDIO DEALER.



The lightning flash with an arrow triangular symbol is intended to alert the user to the presence of uninsulated "dangerous voltage" within the products enclosure, and may be of sufficient magnitude to constitute a risk of electric shock.



The exclamation point triangular symbol is intended to alert the user to the presence of important operating and maintenance (servicing) instructions in the user manual accompanying the CD player.



For optimum performance and reliability **DO NOT PRESENT THE AMPLIFIER WITH A SPEAKER LOAD OF LESS THAN 2 OHMS. OR ANY COMBINATION OF SPEAKERS THAT TOGETHER ARE LESS THAN 2 OHMS PER SIDE!**

- Using one speaker, it must be rated at 2 ohms minimum.
- Using two speakers, they must be rated each at 4 ohms minimum.
- Using three speakers, they must be rated each at 8 ohms minimum.



Pour assurer la Fiabilite et obtenit une performance optimale, ne soumette jamais l'amplificateur a une charge d'impedance totale inferieure a 2 ohms, ni avec un H.P. ni en com binasion des H.P.

AVEC un H.P., il Faut une charge d'impedance minimum de 2 ohms.
AVEC deux H.P., il Faut pour chaoun une charge d'impedance minimum de 4 ohms.
AVEC trois H.P. il Faut pour chaon une charge d'impedance minimum de 8 ohms.

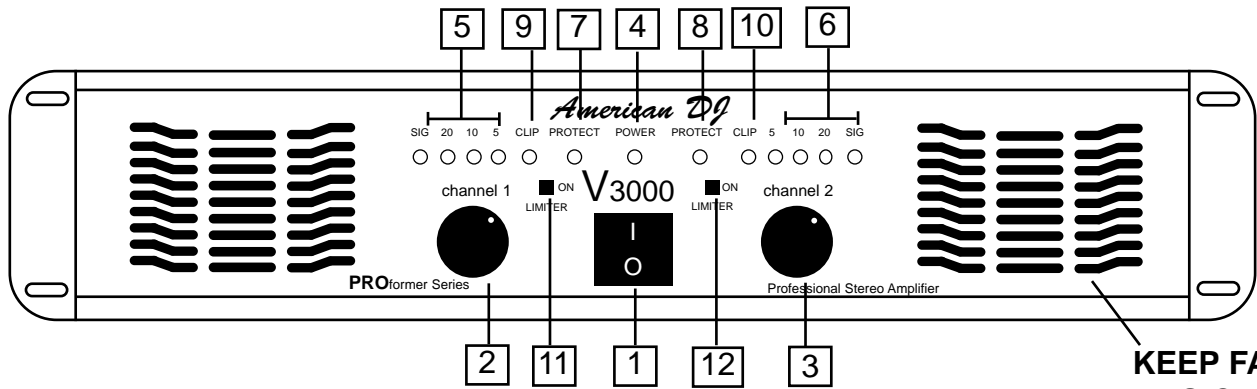

- 1: Power Switch
- 2: Channel 1 gain controls
- 3: Channel 2 gain controls
- 4: Power ON indicator
- 5: Channel 1 indicators
- 6: Channel 2 indicators

- 7: Channel 1 protect indicators
- 8: Channel 2 protect indicators
- 9: Channel 1 clip indicator
- 10: Channel 2 clip indicator
- 11: Channel 1 limiter switch
- 12: Channel 2 limiter switch

KEEP FAN GATES CLEAN!

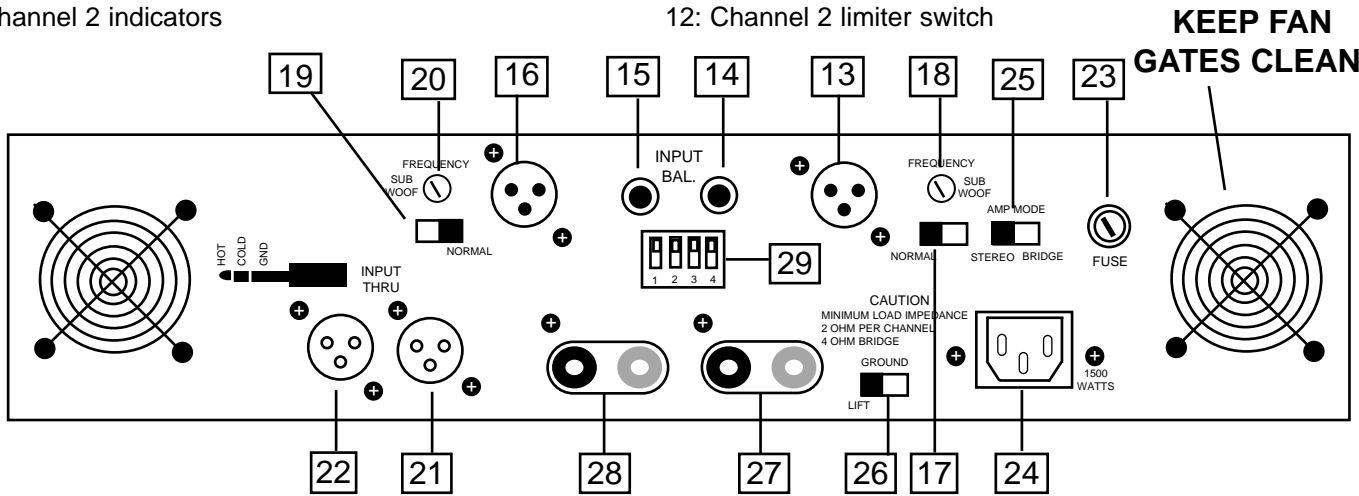

- 13: Channel 1 XLR input
- 14: Channel 1 TRS input
- 15: Channel 2 TRS input
- 16: Channel 2 XLR input
- 17: Channel 1 subwoof on/off switch (V3000 ONLY)
- 18: Channel 1 subwoof frequency adj. (V3000 ONLY)
- 19: Channel 1 subwoof on/off switch (V3000 ONLY)
- 20: Channel 1 subwoof frequency adj. (V3000 ONLY)

- 21: Channel 1 input THRU jack
- 22: Channel 2 input THRU jack
- 23: Fuse holder
- 24: AC cord outlet
- 25: Amplifier mode switch
- 26: Ground lift switch
- 27: Channel 1 output jack
- 28: Channel 2 output jack
- 29: Function settings dip switch

KEEP FAN GATES CLEAN!

STEREO (Typical Settings)

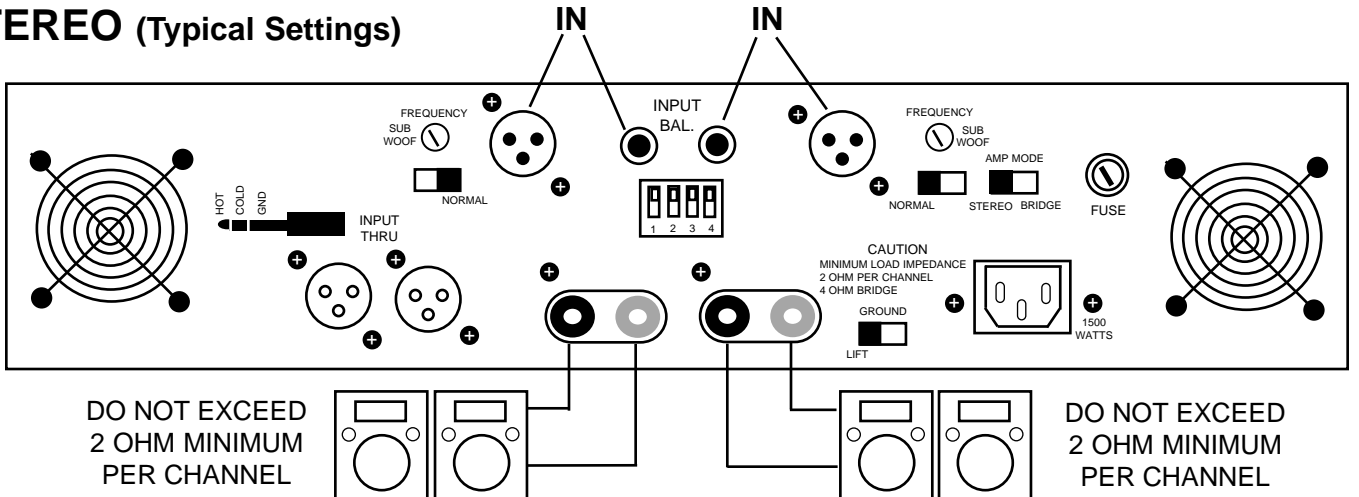

BRIDGE MONO (Typical Settings)

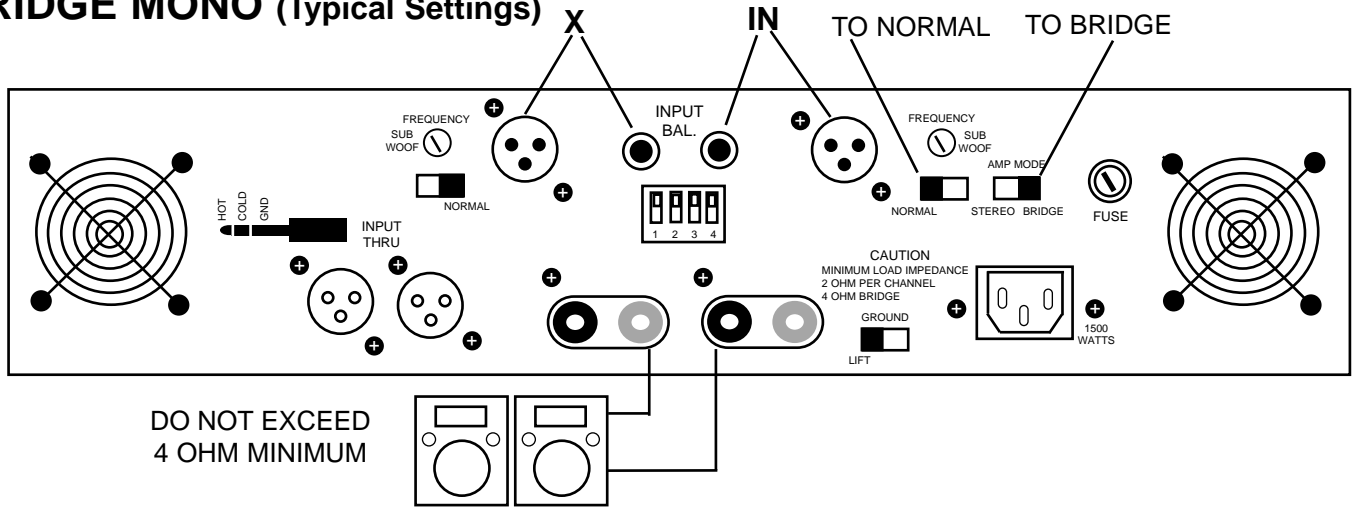

STEREO SUBWOOF

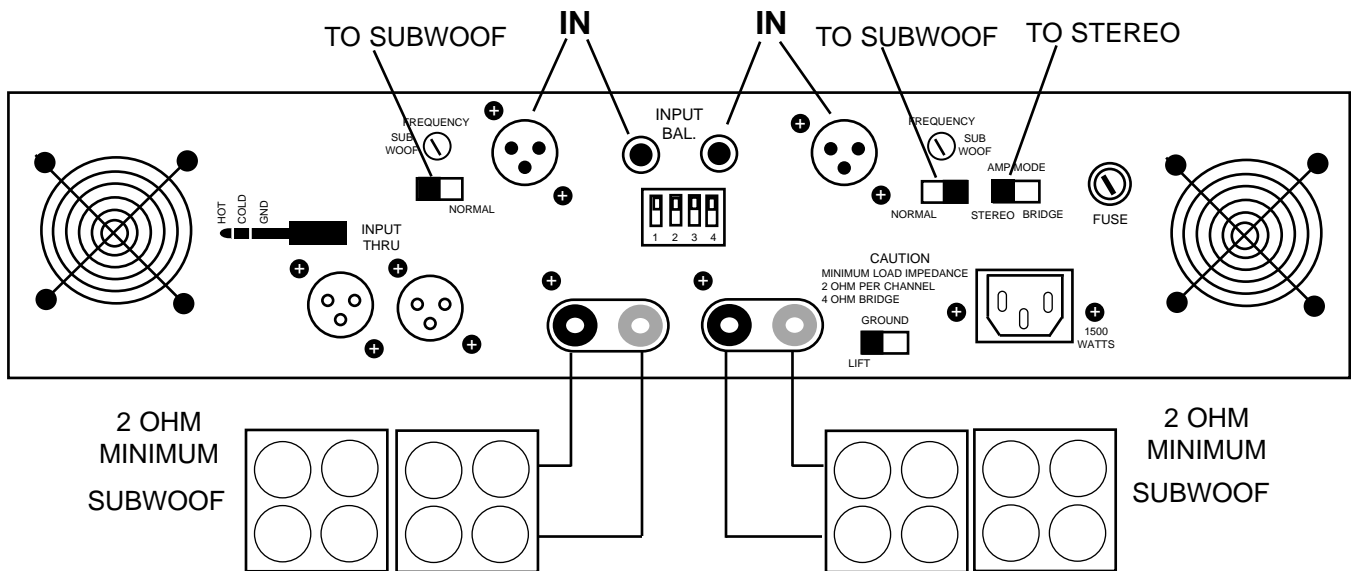

ONE NORMAL / ONE SUBWOOF (BI-AMP)

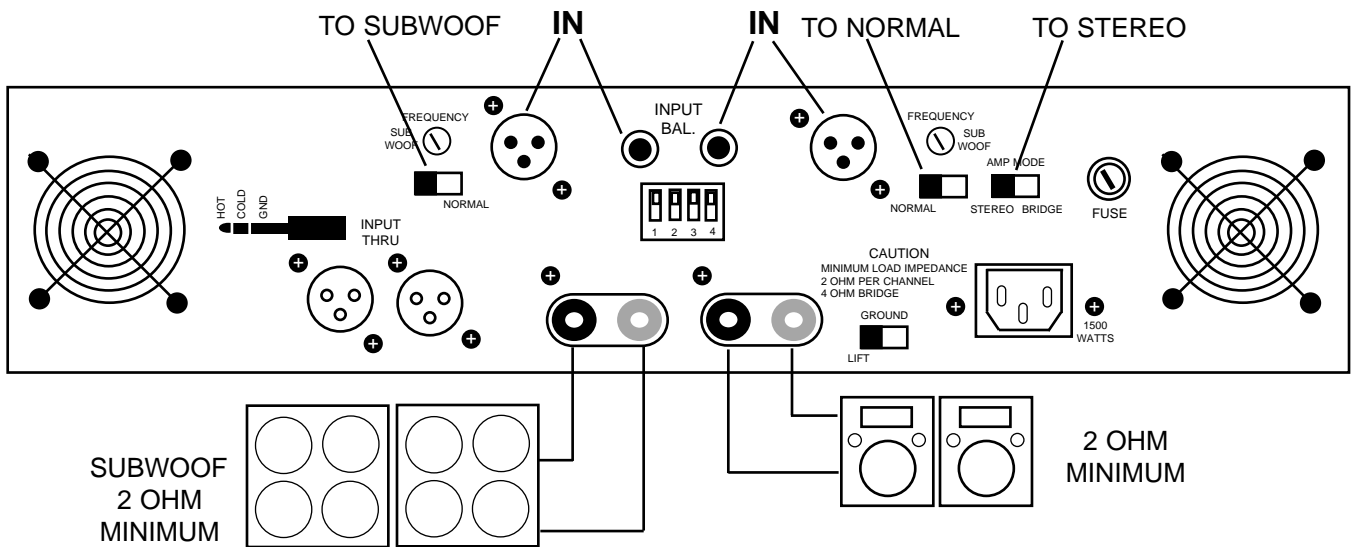

BRIDGE SUBWOOF (V3000 ONLY)

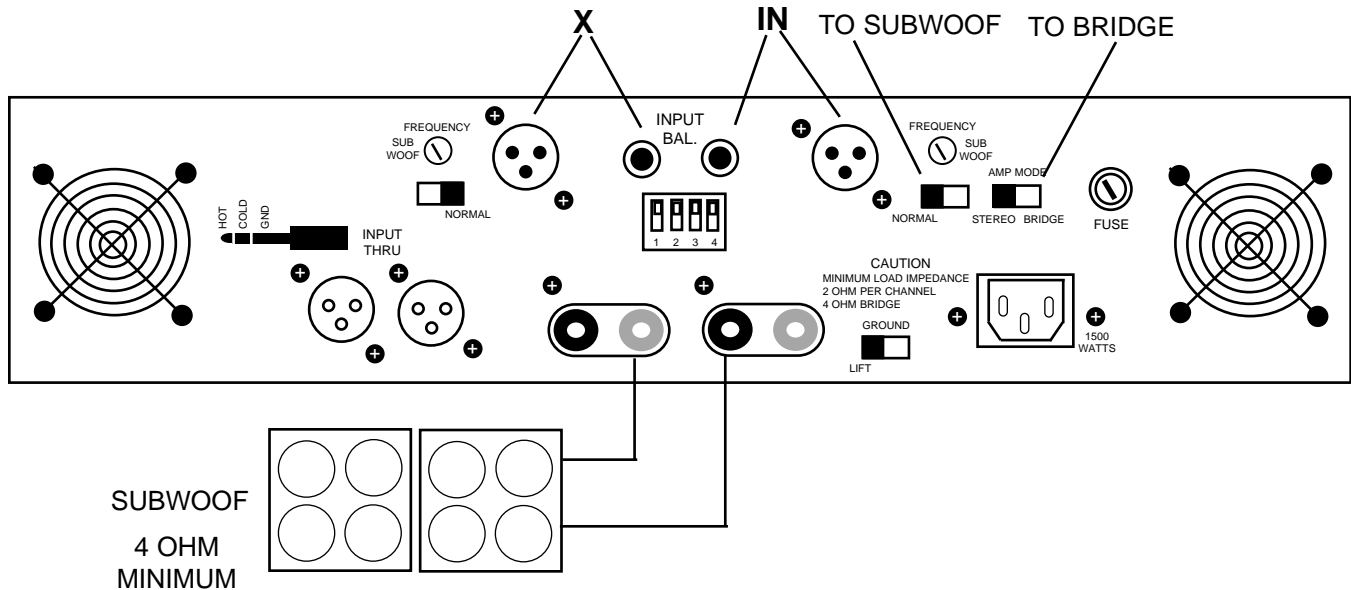

SUBWOOFER (V3000 ONLY)

The subwoofer can be operated in stereo or bridge mono, set the switch to subwoofer position depending on your application, select the frequency from 20 Hz to 200 Hz via variable frequency selector.

AMP MODE (STEREO/BRIDGE)

The Amplifier mode should be configured before operation, if you want to change it during performance, you must decrease the gain controls to protect the speakers from any popping noise.

THRU

Thru will allow the user to daisy-chain one amplifier's signal input into another amplifier. Plug the signal source outputs into the first amplifier's input, patch from the amplifier's THRU jacks to the next amplifier's input, and so on, daisy-chaining as many amplifiers as there is no excessive level loss. Is not affected by crossover setting.

GROUND LIFT SWITCH

Applying or lifting the ground switch will change level for background noise and hum, if the noise level remains the same in either position, better to keep the ground lift switch in the ground position. This will eliminate 60Hz cycle Hum that is sometimes induced when mounting several units in the same rack.

OPERATING VOLTAGE (AC mains)

The serial number label indicates the correct AC main voltage. Connecting to the wrong voltage is dangerous and may damage the amplifier.

INPUTS

Two input connector, XLR jack for balance and 6.3mm (1/4") TRS jack for unbalance.

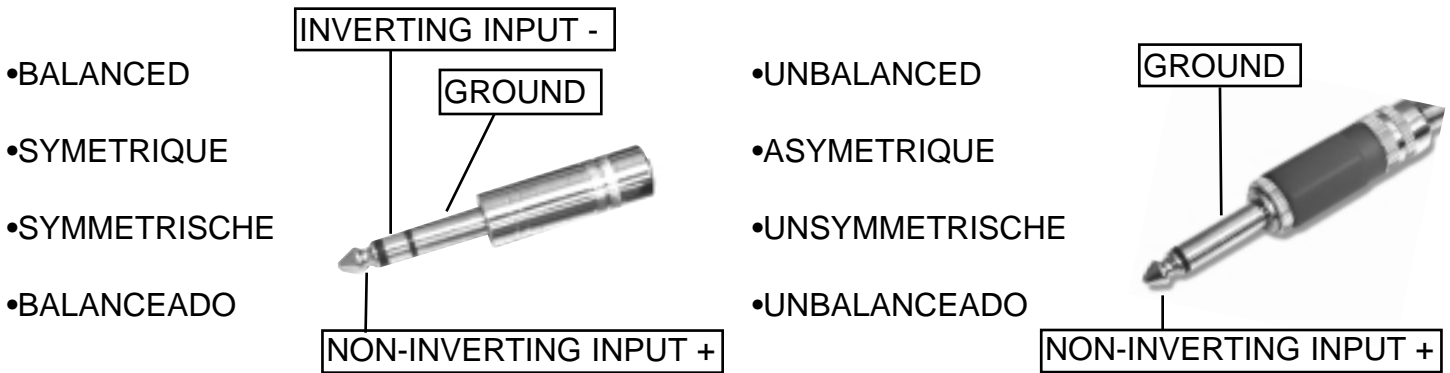

OUTPUTS (Banana Jack Connection)

Strip back insulation 13-mm. Insert wire fully, tighten barrel.

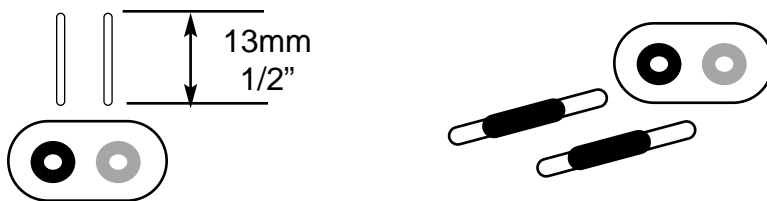

LIMITER

The limiter has a fixed threshold and will prevent continuous clipping. Below clipping, and during short clips on peaks, the limiter does not act on the audio signal. The limiter for either channel can be disabled independently using the slide switch on the front panel.

LOW CUT FILTER

The low-cut filter removes ultra-low frequency information from the audio signal that could damage or cause distortion in a loud speaker system. The dip switch on the rear panel allows you to enable or disable the filter independently for either Channel, as well as set it for either a 50Hz or 30 Hz cut-off. Always use the 50 Hz filter setting if you are using the amplifier to drive a distributed line system (also known as a constant-voltage line, 70 volt line, etc.)

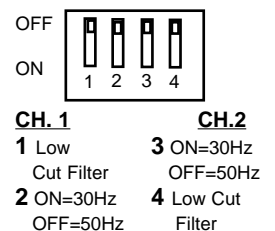

OPERATION

CONFIGURING THE AMPLIFIER

A 4-position dip switch on the rear panel allows you to configure certain amplifier characteristics. A diagram on the rear panel shows the individual switch functions and settings..

LOW-CUT FILTER: Setting position 1 to “ON” enables the low-cut filter on channel 1 and “OFF” disables it. Position 4 does the same for channel 2.

LOW-CUT FILTER FREQUENCY SELECTOR: When setting position 1 or 4 to “ON” then position 2 or 3 up to cut-off of 30 Hz and down is for 50 Hz.

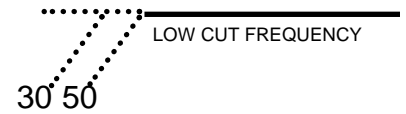

GAIN CONTROLS

The gain controls are located on the front panel and are calibrated in DB of attenuation from full gain. It is best to adjust the amplifier so no “hissing” is heard from speakers with no music being played.

LED INDICATORS

Each channel has 6 LEDs. 2 green LED and 2 yellow LED for level indication, 1 red LED for power clips, 1 red LED for short / overload, and the green LED at center for power indicator.

BUILT IN PROTECTION

LIMITER: During signal overload, the limiter will reduce the input audio signal enough to minimize the amount of clipping. During normal operation, the limiter does not affect the audio signal. It will allow brief clipping of peaks and will only activate when continuous, hard clipping occurs. When the signal amplitude decreases enough that clipping ends, the limiter will deactivate and cease its gain reduction. When the input signal overloads, the “CLIP LED’s” indicate a signal overload. At this time, the “LIMITER” switch on the front panel should be in the “ON” position or the master volume should be lowered to reduce distortion.

INPUT/OUTPUT PROTECTION: The input circuits are isolated by 10k resistors. An ultrasonic network decouples **RF (radio frequency)** from the output and helps keep the amplifier stable with reactive loads.

THERMAL PROTECTION: Variable-speed fans provides cooling airflow. During low level output the fan runs at normal speeds. During high output and as heat raises, (exceeding 90°C), the fan will run at high speed to aid the cooling process. The amplifier will mute until it cools down.

SHORT CIRCUIT PROTECTION: The Output Short Circuit Protection protects the output devices from short circuits and stressful loads. During short circuit protection, the “CLIP LED” and “PROTECT LED” will light simultaneously indicating amp fault. All channel output will be interrupted (i.e. no sound output), during the “**SHORT CIRCUIT PROTECTION.**” **SHORT CIRCUIT PROTECTION** can usually be traced back to the signal output line (i.e. Speaker Line). Check the line from the output terminal to the speaker. If this line is good, check the internal speaker connections and components. A short circuit will usually be traced to a bad cable or a bad speaker and is rarely traced to the amplifier itself.

SPECIFICATIONS

MODEL NO:	V-3000	V-2000 MK II
Output Power: 2 ohms, 1 khz 1% THD 4 ohms, 1khz, 1% THD 8 ohms, 1khz 1% THD (Bridge Mode, mono) 4 ohms, 1khz, 1% THD 8 ohms, 1khz, 1% THD	800W RMS PER CHANNEL 630W RMS PER CHANNEL 400W RMS PER CHANNEL 1500 WATTS RMS 1100 WATTS RMS	540W RMS PER CHANNEL 400W RMS PER CHANNEL 250W RMS PER CHANNEL 1050 WATTS RMS 820 WATTS RMS
Total Harmonic Distortion: 20Hz-20khz, @ rated output power, 8 ohms	Less than 0.1%	Less than 0.1%
Input Sensitivity & Impedance: @ rated output power, 8 ohms	1.0 RMS (0 dBv)	1.0 RMS (0 dBv)
Dimensions & Weight: Height: Width: Depth: Weight:	3.5" (8.8cm) 19" (48.3cm) 15.9" (40.5cm) 35 lbs. (14 kg.)	3.5" (8.8cm) 19" (48.3cm) 15.9" (40.5cm) 31 lbs. (14 kg.)
Frequency Response: +/- 1db, 1w RMS. 8 ohms +/- 0.2 db, @ rated output, 8 ohms	10 Hz- 40 kHz 20 Hz- 40 kHz	10 Hz- 40 kHz 20 Hz- 40 kHz
Hum & Noise: Below rated output, 8 ohms	100 dB, unweighted	100 dB, unweighted
Power Consumption: @rated output power,8 ohms	12A @ 120v AC	10A @ 120v AC
Cooling System:	Dual 2 speed fans and heatsink	Dual 2 speed fans and heatsink

American DJ® World Headquarters:
 4295 Charter Street Los Angeles, CA 90058 USA
 Tel: 323-582-2650 • Fax: 323-582-2610
 web: www.americandj.com • e-mail: info@americandj.com

Free Manuals Download Website

<http://myh66.com>

<http://usermanuals.us>

<http://www.somanuals.com>

<http://www.4manuals.cc>

<http://www.manual-lib.com>

<http://www.404manual.com>

<http://www.luxmanual.com>

<http://aubethermostatmanual.com>

Golf course search by state

<http://golfingnear.com>

Email search by domain

<http://emailbydomain.com>

Auto manuals search

<http://auto.somanuals.com>

TV manuals search

<http://tv.somanuals.com>