

12•20-RTM

RE THERM & FOOD HOLDING OVEN WITH ROLL-IN CART



- HALO HEAT . . . a controlled, uniform heat source that gently rethermalizes or regenerates prepared meals and bulk foods to proper serving temperatures and automatically converts to hot food holding to provide a safe and prolonged holding environment for rethermalized foods.
- Rethermalizes foods within the two-hour time period required by U.S. Food Code.
- Close temperature tolerance and uniform heat distribution reheats evenly, maintaining an ideal serving temperature throughout the cabinet.
- Retherm oven is furnished with a roll-in cart (trolley).
- An optional roll-in cart features removable pan slide panels to stack optional wire baskets for individual entrée rethermalization.
 - Up to twenty-four full-size pans (GN 1/1) or twelve sheet pans.
 - Up to twenty-six wire baskets to retherm individual entrées.
- Non-magnetic stainless steel interior resists corrosion.
- Manual control configurations include an adjustable retherm thermostat, holding thermostat, and 4-hour timer.
- Electronic control models provide complete operating function, automatic preheating, and memory storage for up to eight individual operator set retherm programs. Digital display monitors inside air temperature of the oven programmed operating parameters.



Single compartment, mobile oven with a retherm thermostat temperature range of 100° to 400°F (38° to 204°C) and a holding temperature range of 60° to 240°F (16° to 116°C). Oven includes 20 gauge stainless steel exterior, door handle with positive latch, two (2) exterior handles for maneuverability, and is supported by four (4) 5-inch (127mm) heavy duty casters, 2 rigid and 2 swivel with brake.

Electronic control includes a 4-digit LED display, ON/OFF key, retherm temperature key, and holding temperature key. Control also includes retherm mode count-down timer, up and down arrow keys for time and temperature adjustment, miscellaneous indicator lights for operational status, and a start key. The control features eight (8) programmable menu keys with the ability to set individual retherm, hold, and time parameters. The control has an automatic preheat program and built-in lock out feature.

Manual control configuration includes an ON/OFF power switch, adjustable retherm thermostat, and holding temperature thermostat. Control also includes a 4-hour timer, and an exterior gauge to monitor internal oven air temperature.

Each retherm oven is furnished with one (1) roll-in cart (trolley) which features non-tilt pan support rails.

- MODEL 12•20-RTM/ e: Single compartment mobile oven with electronic control
- MODEL 12•20-RTM: Single compartment mobile oven with manual control configuration

FACTORY INSTALLED OPTIONS

- Left-hand door hinging is standard.
 - Specify right-hand doors as a special order.
- Entrée containers are not included.
- Optional HACCP Documentation web-based software provides the ability to monitor, store, and print all relevant data.
- Optional HACCP with Kitchen Management web-based software provides the ability to program, control, monitor, and store all relevant data.



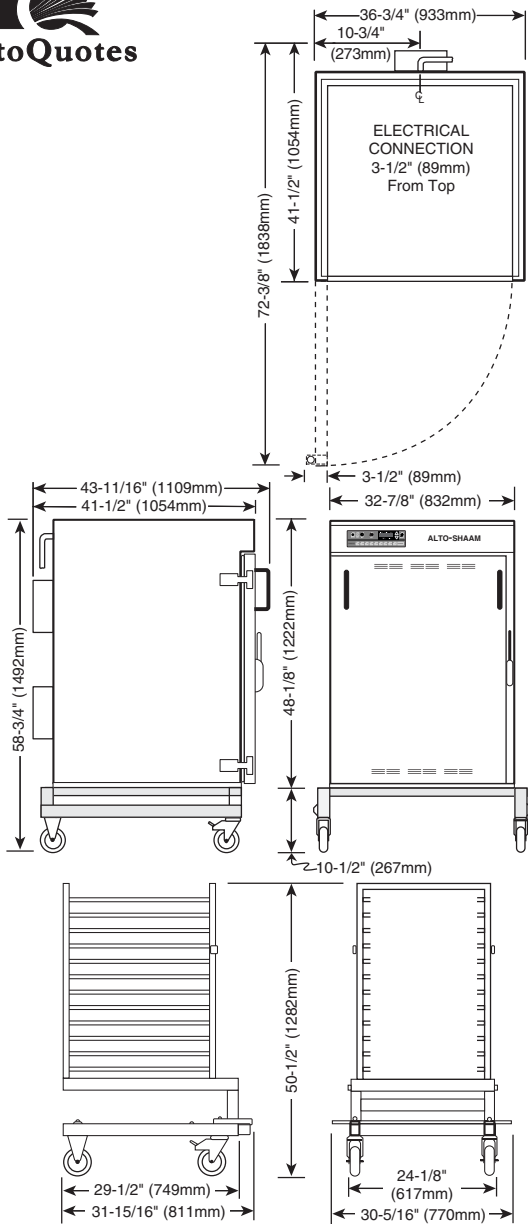

DIMENSIONS: H x W x D	
EXTERIOR:	58-3/4" x 36-3/4" x 43-11/16" (1492mm x 933mm x 1109mm)
INTERIOR:	39" x 28-1/8" x 35" (991mm x 714mm x 889mm)

ELECTRICAL (Retherm Connections)						
	VOLTAGE	PHASE	CYCLE/HZ	AMPS	kW	AWG
208-240	208	1	60	31.0	6.50	BARE END - NO PLUG
	240	1	60	29.8	7.20	CORD INCLUDED
230	at 220	1	50/60	32.8	7.20	CORD INCLUDED
	at 230	1	50/60	28.5	6.60	SEE BELOW
220-240	at 220	3	60	19.0	7.20	CORD INCLUDED
	at 240	3	60	17.9	7.20	SEE BELOW
380-415	at 380	3	50/60	11.0	7.20	CORD INCLUDED
	at 415	3	50/60	10.1	7.20	SEE BELOW

DOMESTIC MODELS FOR SHIPMENT WITHIN USA ARE FURNISHED WITH SINGLE POWER CORD (BARE END, NO PLUG)

MODELS FOR SHIPMENT TO DESTINATIONS OUTSIDE USA ARE FURNISHED WITH ONE POWER CORD CONNECTION FOR REGENERATING AND A SEPARATE POWER CORD CONNECTION FOR FOOD HOLDING

Holding Connections						
	at 220	1	60	9.0	2.20	CORD INCLUDED
	at 240	1	60	10.5	2.50	BARE END - NO PLUG

PRODUCT/PAN CAPACITY	
288 lbs (131 kg) MAXIMUM VOLUME MAXIMUM 180 QUARTS (228 LITERS)	
PANS:	
	FULL-SIZE PANS GASTRONORM 1/1
Twenty-four (24)	20" x 12" x 2-1/2" 530mm x 325mm x 65mm
	FULL SIZE SHEET PANS
Twelve (12)	18" x 26" x 1"
WITH OPTIONAL WIRE SHELVES	
WIRE-ENTRÉE BASKETS:	
Twenty-six (26) #53	13" x 20" (330mm x 508mm)
	ENTRÉE PANS PER BASKET: 8
	ENTRÉE PANS PER CART: 208
	ENTRÉE PAN SIZE: 6-1/2" x 5" (165mm x 127mm)
ROLL-IN CART (TROLLEY) #5814	
— Twelve (12) pan support rail positions	
2-5/8" (67mm) vertical spacing between rails	
21-1/8" (537mm) horizontal width between rails	

WEIGHT	
NET: 405 lb (184 kg)	SHIP: 510 lb (231 kg)
CRATE DIMENSIONS: (H x W x D)	
64" x 44" x 47" (1626mm x 1118mm x 1194mm)	

CLEARANCE REQUIREMENTS
6-inches (152mm) at the back, top, and both sides
INSTALLATION REQUIREMENTS
— Oven must be installed level.
— The oven must not be installed in any area where it may be affected by steam, grease, dripping water, extreme temperatures, or any other severely adverse conditions.

OPTIONS & ACCESSORIES	
HACCP Network Options (ELECTRONIC CONTROL ONLY)	<input type="checkbox"/> Preheat Sealing Strip 1000664
REFER TO SPECIFICATION #9015 FOR APPLICABLE PART NUMBERS	<input type="checkbox"/> Probe, internal product temperature (ELECTRONIC CONTROL ONLY) AVAILABLE
<input type="checkbox"/> HACCP Documentation	<input type="checkbox"/> Stainless Steel Wire Shelf SH-22473
<input type="checkbox"/> HACCP with Kitchen Management	— TO ACCOMMODATE FULL-SIZE SHEET PAN
<input type="checkbox"/> Cart, Roll-in	<input type="checkbox"/> Wire Entrée Basket
with Removable Pan Rail Supports 5000723	— 13" x 20" #53 (330mm x 508mm) BS-25591

Free Manuals Download Website

<http://myh66.com>

<http://usermanuals.us>

<http://www.somanuals.com>

<http://www.4manuals.cc>

<http://www.manual-lib.com>

<http://www.404manual.com>

<http://www.luxmanual.com>

<http://aubethermostatmanual.com>

Golf course search by state

<http://golfingnear.com>

Email search by domain

<http://emailbydomain.com>

Auto manuals search

<http://auto.somanuals.com>

TV manuals search

<http://tv.somanuals.com>