

FOR PERFECT RESULTS

Thank you for choosing this AEG product. We have created it to give you impeccable performance for many years, with innovative technologies that help make life simpler – features you might not find on ordinary appliances. Please spend a few minutes reading to get the very best from it.

ACCESSORIES AND CONSUMABLES

In the AEG webshop, you'll find everything you need to keep all your AEG appliances looking spotless and working perfectly. Along with a wide range of accessories designed and built to the high quality standards you would expect, from specialist cookware to cutlery baskets, from bottle holders to delicate laundry bags...



Visit the webshop at:
www.aeg.com/shop

CONTENTS

4	Safety information
7	Product description
8	Before first use
8	Daily use
9	Using the accessories
10	Additional functions
10	Helpful hints and tips
20	Care and cleaning
23	What to do if...
23	Installation
25	Environment concerns
26	Major Appliance Warranty Information

The following symbols are used in this user manual:



Important information concerning your personal safety and information on how to avoid damaging the appliance.



General information and tips



Environmental information

Subject to change without notice



SAFETY INFORMATION

Before the installation and use, read this manual carefully:

- For your personal safety and the safety of your property
- For the respect of the environment
- For the correct operation of the appliance.

Always keep these instructions with the appliance also if you move or sell it.

The manufacturer is not responsible if incorrect installation or use results in damage.

Children and vulnerable people safety

- This appliance can be used by children aged from 8 years and above and persons with reduced physical, sensory or mental capabilities or lack of experience and knowledge if they have been given supervision or instruction concerning use of the appliance in safe way and understand the hazards involved. Children shall not play with the appliance.
- Keep all packaging away from children. There is the risk of suffocation or physical injury.
- **WARNING:** Keep children and animals away from the appliance when the door is open or the appliance is in the operation, because it becomes hot. There is the risk of injury or other permanent disability.
- If the appliance has Child Lock or Key Lock (Control Lock) function, use it. It prevents children and animals from accidental operation of the appliance.

General safety

- Do not change the specifications of this appliance. There is the risk of injury and damage to the appliance.
- Do not let the appliance stay unattended during operation.
- Switch off the appliance after each use.

Installation

- Only an approved electrician can install and connect the appliance. Contact an approved service centre. This is to prevent the risks of structural damage or physical injury.
- Make sure that the appliance is not damaged because of transport. Do not connect a damaged appliance. If necessary, contact the supplier.
- Remove all packaging, stickers and layers from the appliance before first use. Do not remove the rating plate. It can invalidate the guarantee.
- Make sure that the appliance is disconnected from the power supply during the installation.
- Be careful when you move the appliance. The appliance is heavy. Always use safety gloves. Do not lift the appliance by the handle.
- The electrical installation must have an isolation device which lets you disconnect the appliance from the mains at all poles. The isolation device must have a contact opening width of minimum 3 mm.
- You must have correct isolation devices: line protecting cut-outs, fuses (screw type fuses removed from the holder), earth leakage trips and contactors.

- Before the installation, make sure that the kitchen cabinet has the recess dimensions applicable.
- Make sure that the appliance is installed below and adjacent safe structures.
- Keep the minimum distances to the other appliances and units.
- The appliance cannot be positioned on a base.
- Built in ovens and built in cooking surfaces are attached with special connection system. To prevent damage to the appliance, only use an appliance with the appliances from the same manufacturer.

Electrical connection

- The appliance must be earthed.
- Make sure that the electrical data on the rating plate agree with your domestic power supply.
- Information on the voltage is on the rating plate.
- Always use a correctly installed shockproof socket.
- Do not use multi-way plugs, connectors and extension cables. There is the risk of fire.
- Do not replace or change the mains cable. Contact the service centre.
- Make sure not to squash or cause damage to the mains plug (if applicable) and cable behind the appliance.
- Do not pull the mains cable to disconnect the appliance. Always pull the mains plug – if applicable.

Use

- The appliance is only for domestic use. Do not use the appliance for commercial and industrial use.
- Only use the appliance for domestic cooking tasks. This is to prevent physical injury to persons or prevent damage to property.
- Do not use the appliance as a work surface or storage surface.
- The interior of the appliance becomes hot during use. There is the risk of burns. Do not touch the heating elements in the appliance. Use gloves when you insert or remove the accessories or pots.
- Be careful when you remove or install the accessories to prevent damage to the oven enamel.
- Always stay away from the appliance when you open the door while the appliance is in operation. Hot steam can release. There is the risk of skin burns.
- To prevent damage or discoloration to the enamel:
 - Do not put any objects directly on the appliance floor and do not cover it with aluminium foil.
 - Do not put water directly into the hot appliance.
 - Do not keep moist dishes and food in the appliance after you finish the cooking.
- Discoloration of the enamel has no effect on the performance of the appliance so it is not a defect in the sense of the warranty law.
- Do not apply pressure on the open door.

- Always close the appliance door when you cook, even while grilling.

Care and cleaning

- Before maintenance, switch off the appliance and disconnect the appliance from the power supply.
- Before maintenance, make sure that the appliance is cold. There is the risk of burns. There is the risk that the glass panels can break.
- Keep the appliance clean at all times. A build-up of fats or other foodstuff can result in a fire.
- Regular cleaning prevents the surface material from deteriorating
- Use a deep baking tray for very moist cakes to prevent that fruit juices cause stains that can be permanent.
- For your personal safety and the safety of your property, only clean the appliance with water and a soap. Do not use flammable products or products that can cause corrosion.
- Do not clean the appliance with steam cleaners, high-pressure cleaners, sharp objects, abrasive cleaning agents, abrasive sponges and stain removers
- If you use an oven spray, follow the instructions from the manufacturer.
- Do not clean the glass door with abrasive cleaning agents or metal scraper. Heat resistant surface of the inner glass can break and shatter.
- When the door glass panels are damaged they become weak and can break. You must replace them. Contact the service centre.
- Be careful when you remove the door from the appliance. The door is heavy!
- Do not clean catalytic enamel (if applicable).

Risk of fire

- Open the door carefully. The use of ingredients with alcohol can cause a mixture of alcohol and air. There is the risk of fire.
- Do not let sparks or open flames come near the appliance when you open the door.
- Do not put flammable products or items that are wet with flammable products, and/or fusible objects (made of plastic or aluminium) in, near or on the appliance.

Oven lamp

- The type of light bulb or halogen lamp used for this appliance is only for household appliances. Do not use it for house lighting.
- If it becomes necessary to replace the lamp, use one of the same power and specifically designed for household appliances only.
- Disconnect the appliance from the power supply before the replacement of the oven lamp. There is the risk of electrical shock.

Service centre

- Only an approved engineer can repair or work on the appliance. Contact an approved service centre.
- Use only original spare parts.

Disposal of the appliance

- To prevent the risk of physical injury or damage
 - Disconnect the appliance from the power supply.
 - Cut off the mains cable and discard it.
 - Discard the door catch. This prevents children or small animals from being closed inside of the appliance. There is the risk of suffocation.

PRODUCT DESCRIPTION

General overview

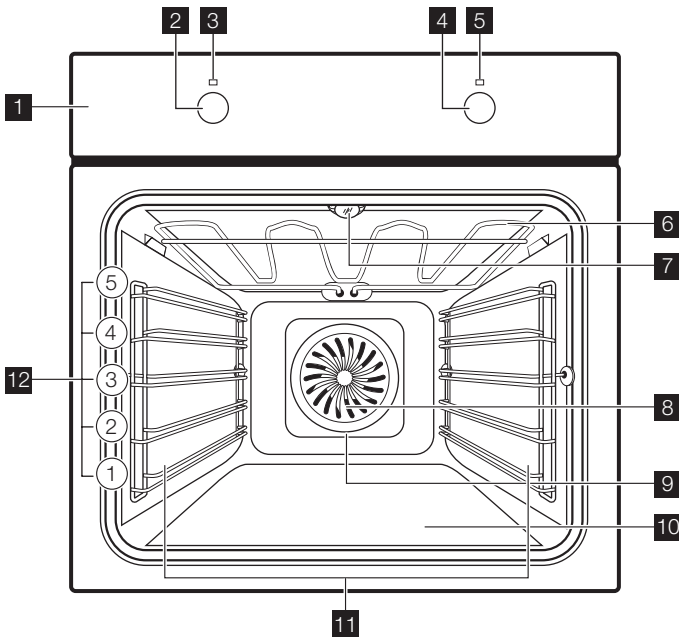

- 1** Control panel
- 2** Control knob for oven functions
- 3** Power lamp/symbol
- 4** Control knob for temperature
- 5** Temperature lamp/symbol/indicator
- 6** Heating element
- 7** Oven lamp
- 8** Fan
- 9** Rear wall heating element
- 10** Bottom heat

11 Shelf support, removable

12 Shelf positions

Accessories

- Wire shelf
For cookware, cake tins, roasts.

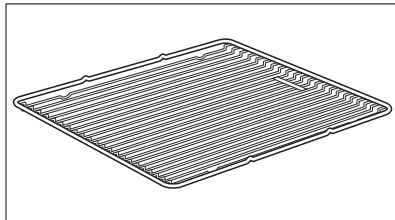

- Combi pan
For cake and biscuits. To bake and roast or as a pan to collect fat.

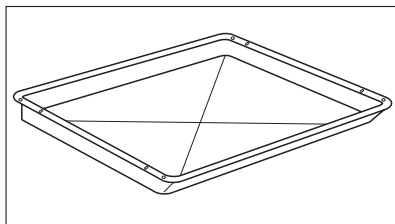

BEFORE FIRST USE



WARNING!

Refer to "Safety information" chapter.

Initial Cleaning

- Remove all parts from the appliance.
- Clean the appliance before first use.



Refer to chapter "Care and Cleaning".

DAILY USE



WARNING!

Refer to "Safety information" chapter.

To use the appliance, press the control knob. The control knob comes out.

Activating and deactivating the appliance

1. Turn the control knob for the oven functions to select an oven function.
2. Turn the control knob for the temperature to select a temperature.









3. To deactivate the appliance turn the control knobs for the oven functions and temperature to off position.



Knob symbol, indicator or lamp (depends on the model - refer to the appliance overview):

- The indicator comes on when the oven heats up.
- The lamp comes on when the appliance operates.
- The symbol shows whether the knob controls one of the cooking zones, the oven functions or the temperature.

Oven Functions

Oven function	Application
 Light	Use this function to light up the oven interior.
 True Fan Cooking	To bake maximum on three oven levels at the same time. Decrease the oven temperatures (68-104 °F) compared with Conventional. And to dry food.
 Pizza Setting	To bake on one oven level food with a more intensive browning and a crispy base. Decrease the oven temperatures (68-104 °F) compared with Conventional
 Conventional Cooking	To bake and roast on one oven level.
 Bottom Heat	To bake cakes with crispy or crusty bases and to preserve food
 Defrost	To defrost frozen food.
 Grilling	To grill flat food in the middle of the grill and to toast.
 Fast Grilling	To grill flat food in large quantities and to toast.
 Turbo Grilling	To roast larger joints of meat or poultry on one level. Also for browning food e.g. gratin.

USING THE ACCESSORIES



WARNING!

Refer to "Safety information" chapter.

Installing the Oven Accessories

- i** The deep pan and the wire shelf have side edges. These edges and the shape of the guide-bars causes the anti-tilt safety for the oven accessories.

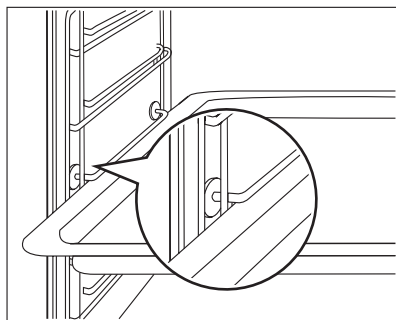

Installing the wire shelf and the deep pan together

Put the wire shelf on the deep pan. Push the deep pan between the guide-bars of one of the oven levels.

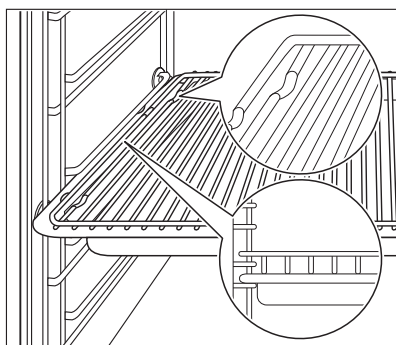

ADDITIONAL FUNCTIONS

Cooling fan

When the appliance operates, the cooling fan activates automatically to keep the surfaces of the appliance cool. If you deactivate the appliance, the cooling fan can continue to operate until the appliance cools down.

HELPFUL HINTS AND TIPS

Inner side of door

In some models on the inner side of the door you can find:

- the numbers of the shelf positions (selected models)
- information about the heating functions, recommended shelf positions and temperatures for typical dishes (selected models).

- i** The temperature and baking times in the tables are guidelines only. They depend on the recipes, quality and quantity of the ingredients used.

Baking

General instructions

- Your new oven may bake or roast differently to the appliance you had before. Adapt your usual settings (temperature, cooking times) and shelf positions to the values in the tables.
- With longer baking times, the oven can be switched off about 10 minutes before the end of baking time, to use the residual heat.

When you use frozen food, the trays in the oven can twist during baking. When the trays get cold again, the distortion will be gone.

How to use the Baking Tables

- We recommend to use the lower temperature the first time.
- If you cannot find the settings for a special recipe, look for the one that is almost the same.
- Baking time can be extended by 10-15 minutes, if you bake cakes on more than one level.
- Cakes and pastries at different heights do not always brown equally at first. If this occurs, do not change the temperature setting. The differences equalize during the baking procedure.

Baking on one level:

Baking in tins

Type of baking	Oven function	Shelf position	Temperature °F	Time in min.
Ring cake or brioche	True Fan Cooking	1	302 - 320	50 - 70
Madeira cake/ fruit cakes	True Fan Cooking	1	284 - 320	70 - 90
Sponge cake	True Fan Cooking	2	284 - 302	35 - 50
Sponge cake	Conventional Cooking	2	320	35 - 50
Flan base - short pastry	True Fan Cooking	2	338-356 ¹⁾	10 - 25
Flan base - sponge mixture	True Fan Cooking	2	302 - 338	20 - 25
Apple pie (2tins Ø20cm, diagonal- ly off set)	True Fan Cooking	2	320	60 - 90
Apple pie (2tins Ø20cm, diagonal- ly off set)	Conventional Cooking	1	356	70 - 90
Cheesecake	Conventional Cooking	1	338 - 374	60 - 90

1) Pre-heat the oven

Cakes/pastries/breads on baking trays

Type of baking	Oven function	Shelf position	Temperature °F	Time in min.
Plaited bread/ bread crown	Conventional Cooking	3	338 - 374	30 - 40
Christmas stollen	Conventional Cooking	2	320 - 356 ¹⁾	50 - 70
Bread (rye bread): 1. First part of baking process. 2. Second part of baking process.	Conventional Cooking	1	1. 446 ¹⁾ 2. 320 - 356	1. 20 2. 30 - 60
Cream puffs/ eclairs	Conventional Cooking	3	374 - 410 ¹⁾	20 - 35
Swiss roll	Conventional Cooking	3	356 - 392 ¹⁾	10 - 20
Cake with crum- ble topping (dry)	True Fan Cooking	3	302 - 320	20 - 40
Buttered almond cake/sugar cakes	Conventional Cooking	3	374 - 410 ¹⁾	20 - 30
Fruit flans (made with yeast dough/ sponge mixture) 2)	True Fan Cooking	3	302	35 - 55
Fruit flans (made with yeast dough/ sponge mixture) 2)	Conventional Cooking	3	338	35 - 55
Fruit flans made with short pastry	True Fan Cooking	3	320 - 338	40 - 80
Yeast cakes with delicate toppings (e. g. quark, cream, custard)	Conventional Cooking	3	320 - 356 ¹⁾	40 - 80

1) Pre-heat the oven

2) Use deep pan

Biscuits

Type of baking	Oven function	Shelf position	Temperature °F	Time in min.
Short pastry bis- cuits	True Fan Cooking	3	302 - 320	10 - 20
Short bread/ Pas- try Stripes	True Fan Cooking	3	284	20 - 35

Type of baking	Oven function	Shelf position	Temperature °F	Time in min.
Short bread/ Pastry Stripes	Conventional Cooking	3	320 ¹⁾	20 - 30
Biscuits made with sponge mixture	True Fan Cooking	3	302 - 320	15 - 20
Pastries made with egg white, merungues	True Fan Cooking	3	176 - 212	120 - 150
Macaroons	True Fan Cooking	3	212 - 248	30 - 50
Biscuits made with yeast dough	True Fan Cooking	3	302 - 320	20 - 40
Puff pastries	True Fan Cooking	3	338 - 356 ¹⁾	20 - 30
Rolls	True Fan Cooking	3	320 ¹⁾	10 - 25
Rolls	Conventional Cooking	3	374 - 410 ¹⁾	10 - 25
Small cakes (20per tray)	True Fan Cooking	3	302 ¹⁾	20 - 35
Small cakes (20per tray)	Conventional Cooking	3	338 ¹⁾	20 - 30

1) Pre-heat the oven

Multileveled Baking

Cakes/pastries/breads on baking trays

Type of baking	True Fan Cooking		Temperature in °F	Time in min.
	Shelf position			
	2 levels	3 levels		
Cream puffs/ Eclairs	1/4	-	320 - 356 ¹⁾	25 - 45
Dry streusel cake	1/4	-	302 - 320	30 - 45

1) Pre-heat the oven

Biscuits/small cakes/pastries/rolls

Type of baking	True Fan Cooking		Temperature in °F	Time in min.
	Shelf position			
	2 levels	3 levels		
Short pastry biscuits	1/4	1/3/5	302 - 320	20 - 40
Short bread/ Pastry Stripes	1/4	1/3/5	284	25 - 50

Type of baking	True Fan Cooking		Temperature in °F	Time in min.
	Shelf position			
	2 levels	3 levels		
Biscuits made with sponge mixture	1/4	-	320 - 338	25 - 40
Biscuits made with egg white, meringues	1/4	-	176 - 212	130 - 170
Macaroons	1/4	-	212 - 248	40 - 80
Biscuits made with yeast dough	1/4	-	320 - 338	30 - 60
Puff pastries	1/4	-	338 - 356 ¹⁾	30 - 50
Rolls	1/4	-	356	30 - 55
Small cakes (20per tray)	1/4	-	302 ¹⁾	25 - 40

1) Pre-heat the oven

Tips on baking

Baking results	Possible cause	Remedy
The cake is not browned enough underneath	Wrong shelf position	Place cake lower
The cake sinks (becomes soggy, lumpy, streaky)	Oven temperature too high	Use a slightly lower setting
The cake sinks (becomes soggy, lumpy, streaky)	Baking time too short	Set a longer baking time. Baking times cannot be reduced by setting higher temperatures
The cake sinks (becomes soggy, lumpy, streaky)	Too much liquid in the mixture	Use less liquid. Pay attention to mixing times, especially if using mixing machines
Cake is too dry	Oven temperature too low	Set oven temperature higher
Cake is too dry	Baking time too long	Set a shorter baking time
Cake browns unevenly	Oven temperature too high and baking time too short	Set a lower oven temperature and a longer baking time
Cake browns unevenly	Mixture is unevenly distributed	Spread the mixture evenly on the baking tray
Cake does not cook in the baking time given	Temperature too low	Use a slightly higher oven setting

Bakes and gratins

Dish	Oven function	Shelf position	Temperature °F	Time in min.
Pasta bake	Conventional Cooking	1	356 - 392	45 - 60
Lasagne	Conventional Cooking	1	356 - 392	25 - 40
Vegetables au gratin ¹⁾	Turbo Grilling or True Fan Cooking	1	320 - 338	15 - 30
Baguettes topped with melted cheese	Turbo Grilling or True Fan Cooking	1	320 - 338	15 - 30
Sweet bakes	Conventional Cooking	1	356 - 392	40 - 60
Fish bakes	Conventional Cooking	1	356 - 392	30 - 60
Stuffed vegetables	Turbo Grilling or True Fan Cooking	1	320 - 338	30 - 60

1) Pre-heat the oven

Roasting

Roasting dishes

- Use heat-resistant ovenware to roast (please read the instructions of the manufacturer).
- Large roasting joints can be roasted directly in the deep pan (if present) or on the wire shelf above the deep pan.
- Roast lean meats in a roasting tin with a lid. This will keep the meat more succulent.
- All types of meat, that can be browned or have crackling, can be roasted in the roasting tin without the lid.

Roasting with Turbo Grilling

Beef

Type of meat	Quantity	Oven function	Shelf position	Temperature °F	Time min.
Pot roast	1-1.5 kg	Conventional Cooking	1	446	120 - 150
Roast beef or fillet: rare	per cm. of thickness	Turbo Grilling	1	374 - 392 ¹⁾	5 - 6
Roast beef or fillet: medium	per cm. of thickness	Turbo Grilling	1	356 - 374 ¹⁾	6 - 8
Roast beef or fillet: well done	per cm. of thickness	Turbo Grilling	1	338 - 356 ¹⁾	8 - 10

1) Pre-heat the oven

Pork

Type of meat	Quantity	Oven function	Shelf position	Temperature °F	Time min.
Shoulder, neck, ham joint	1-1.5 kg	Turbo Grilling	1	320 - 356	90 - 120
Chop, spare rib	1-1.5 kg	Turbo Grilling	1	338 - 356	60 - 90
Meat loaf	750 g-1 kg	Turbo Grilling	1	320 - 338	50 - 60
Porkknuckle (pre-cooked)	750 g-1 kg	Turbo Grilling	1	302 - 338	90 - 120

Veal

Type of meat	Quantity	Oven function	Shelf position	Temperature °F	Time min.
Roast veal	1 kg	Turbo Grilling	1	320 - 356	90 - 120
Knuckle of veal	1.5-2 kg	Turbo Grilling	1	320 - 356	120 - 150

Lamb

Type of meat	Quantity	Oven function	Shelf position	Temperature °F	Time min.
Leg of lamb, roast lamb	1-1.5 kg	Turbo Grilling	1	302 - 338	100 - 120
Saddle of lamb	1-1.5 kg	Turbo Grilling	1	320 - 356	40 - 60

Game

Type of meat	Quantity	Oven function	Shelf position	Temperature °F	Time min.
Saddle of hare, leg of hare	up to 1 kg	Conventional Cooking	1	446 ¹⁾	30 - 40
Saddle of venison	1.5-2 kg	Conventional Cooking	1	410 - 428	35 - 40
Haunch of venison	1.5-2 kg	Conventional Cooking	1	356 - 392	60 - 90

1) Pre-heat the oven

Poultry

Type of meat	Quantity	Oven function	Shelf position	Temperature °F	Time min.
Poultry portions	200-250g each	Turbo Grilling	1	392 - 428	30 - 50
Half chicken	400-500g each	Turbo Grilling	1	374 - 410	35 - 50

Type of meat	Quantity	Oven function	Shelf position	Temperature °F	Time min.
Chicken, pou- lard	1-1.5 kg	Turbo Grilling	1	374 - 410	50 - 70
Duck	1.5-2 kg	Turbo Grilling	1	356 - 392	80 - 100
Goose	3.5-5 kg	Turbo Grilling	1	320 - 356	120 - 180
Turkey	2.5-3.5 kg	Turbo Grilling	1	320 - 356	120 - 150
Turkey	4-6 kg	Turbo Grilling	1	284 - 320	150 - 240

Fish (steamed)

Type of meat	Quantity	Oven function	Shelf position	Temperature °F	Time min.
Whole fish	1-1.5 kg	Conventional Cooking	1	410 - 428	40 - 60

Grilling

Always grill with the maximum temperature setting.



CAUTION!

Always grill with the oven door closed.



Always pre-heat the empty oven with the grill functions for 5 minutes.

- Set the shelf in the shelf position as recommended in the grilling table.
- Always set the pan to collect the fat into the first shelf position.
- Grill only flat pieces of meat or fish.

Grilling

Food to be grilled	Shelf position	Temperature °F	Time in min.	
			1st side	2nd side
Roast beef	2	410 - 446	30 - 40	30 - 40
Filet of beef	3	446	20 - 30	20 - 30
Back of pork	2	410 - 446	30 - 40	30 - 40
Back of veal	2	410 - 446	30 - 40	30 - 40
Back of lamb	3	410 - 446	25 - 35	20 - 25
Whole Fish, 500-1000g	3/4	410 - 446	15 - 30	15 - 30

Fast Grilling

Food to be grilled	Shelf position	Time in min.	
		1st side	2nd side
Burgers	4	8 - 10	6 - 8

Food to be grilled	Shelf position	Time in min.	
		1st side	2nd side
Pork fillet	4	10 - 12	6 - 10
Sausages	4	10 - 12	6 - 8
Fillet steaks, veal steaks	4	7 - 10	6 - 8
Toast ¹⁾	5	1 - 3	1 - 3
Toast with topping	4	6 - 8	-

1) Pre-heat the oven

Pizza Setting

Type of baking	Shelf position	Temperature °F	Time Min.
Pizza (thin crust)	2	392 - 446 ¹⁾²⁾	15 - 20
Pizza (with a lot of topping)	2	356 - 392	20 - 30
Tarts	1	356 - 392	40 - 55
Spinach flan	1	320 - 356	45 - 60
Quiche Lorraine	1	338 - 374	45 - 55
Swiss Flan	1	338 - 374	45 - 55
Apple cake, covered	1	302 - 338	50 - 60
Vegetable pie	1	320 - 356	50 - 60
Unleavened bread	2	446 - 482 ¹⁾	10 - 20
Puff pastry flan	2	320 - 356 ¹⁾	45 - 55
Flammekuchen (Pizza-like dish from Alsace)	2	446 - 482 ¹⁾	12 - 20
Piroggen (Russian version of calzone)	2	356 - 392 ¹⁾	15 - 25

1) Pre-heat the oven

2) Use deep pan

Defrosting

Remove the food packaging. Put the food on a plate.

Do not cover it with a bowl or a plate. This can extend the defrost time.

Use the first oven shelf position. The one on the bottom.

Dish	Defrosting time in min.	Further defrosting time in min.	Comment
Chicken, 1000 g	100 - 140	20 - 30	Place the chicken on an up-turned saucer placed on a large plate Turn halfway through

Dish	Defrosting time in min.	Further defrosting time in min.	Comment
Meat, 1000 g	100 - 140	20 - 30	Turn halfway through
Meat, 500 g	90 - 120	20 - 30	Turn halfway through
Trout, 150 g	25 - 35	10 - 15	-
Strawberries, 300 g	30 - 40	10 - 20	-
Butter, 250 g	30 - 40	10 - 15	-
Cream, 2 x 200 g	80 - 100	10 - 15	Cream can also be whipped when still slightly frozen in places
Gateau, 1400 g	60	60	-

Drying - True Fan Cooking

Cover the oven shelves with baking parchment.

For best results: deactivate the appliance after half the time required. Open the appliance door and let the appliance cool down. After that finish the drying process.

Vegetables

Food to be dried	Shelf position		Temperature in °F	Time in hours (Guideline)
	1 level	2 levels		
Beans	3	1/4	140 - 158	6 - 8
Peppers	3	1/4	140 - 158	5 - 6
Vegetables for sour	3	1/4	140 - 158	5 - 6
Mushrooms	3	1/4	122 - 140	6 - 8
Herbs	3	1/4	104 - 122	2 - 3

Fruit

Food to be dried	Shelf position		Temperature in °F	Time in hours (Guideline)
	1 level	2 levels		
Plums	3	1/4	140 - 158	8 - 10
Apricots	3	1/4	140 - 158	8 - 10
Apple slices	3	1/4	140 - 158	6 - 8
Pears	3	1/4	140 - 158	6 - 9

Information on acrylamides

Important! According to the newest scientific knowledge, if you brown food (specially the one which contains starch), acrylamides can pose a health risk. Thus, we recommend that you cook at the lowest temperatures and do not brown food too much.

CARE AND CLEANING



WARNING!

Refer to "Safety information" chapter.

Notes on cleaning:

- Clean the front of the appliance with a soft cloth with warm water and cleaning agent.
- To clean metal surfaces use a usual cleaning agent.
- Clean the appliance interior after each use. Then you can remove dirt more easily and it does not burn on.
- Clean stubborn dirt with a special oven cleaner.
- Clean all accessories (with a soft cloth with warm water and cleaning agent) after each use and let them dry.
- If you have nonstick accessories, do not clean them using an aggressive agents, sharp edged objects or dishwasher. It can cause a damage to the nonstick coating.

Catalytic walls

The walls with a catalytic coating are self-cleaning. They absorb fat which collects on walls while the oven operates.

To support this self-cleaning process heat the oven without any food regularly:

- Turn the oven light on.
- Remove accessories from the oven.
- Clean the oven floor with warm water and washing up liquid, then dry it.
- Set the  function.
- Set the oven temperature to 482 °F and let oven operate for 1 hour.
- Clean the oven cavity with a soft and damp sponge.



WARNING!

Do not attempt to clean catalytic surface with oven sprays, abrasive cleaners, soap or other cleaning agents. This will damage the catalytic surface.



Discolouration of the catalytic surface has no effect on catalytic properties.

Shelf support

You can remove the shelf support to clean the side walls.

Removing the shelf support

1. Pull the front of the shelf support away from the side wall.

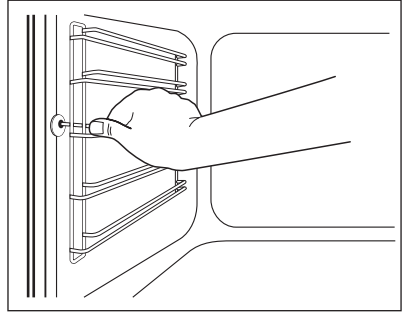

2. Pull the shelf support from the back of the side wall to remove it.

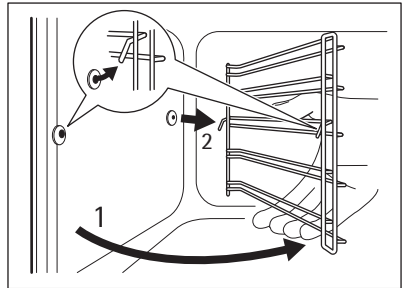

To install the shelf support follow the procedure in reverse.



Valid with telescopic runners:

The retaining pins on the telescopic shelf runners must point to the front!

Oven lamp



WARNING!

There is a risk of electrical shock.

The oven lamp and the lamp glass cover can be hot.

Before you change the oven lamp:

- Deactivate the appliance.
- Remove the fuses from the fuse box or deactivate the circuit breaker.



CAUTION!

Put a cloth on the bottom of the interior of the appliance. It prevents damage to the lamp glass cover and the cavity.

Replacing the oven lamp:

1. You can find the lamp glass cover at the cavity ceiling.
Turn the lamp glass cover counterclockwise to remove it.
2. Clean the glass cover.
3. If necessary, replace the oven lamp with applicable 572°F heat-resistant oven lamp.



Use the same oven lamp type.

4. Install the glass cover.

Door and glass panels

To clean the door, remove it.



CAUTION!

Be careful when you remove the door from the appliance. The door is heavy!

Removing the door

1. Open the door as far as it goes.
2. Fully press clamping levers (A) on the two door hinges.
3. Close the door until the first position (angle approximately 70°).
4. Hold of the door with one hand on each side and pull it away from the at an up angle.

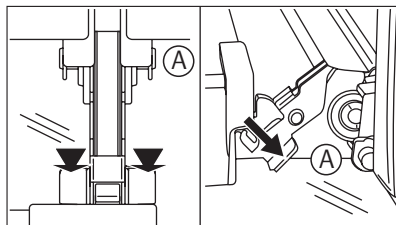

To install the door follow the procedure in reverse.



The number of glass panels is different for the different models.



CAUTION!

Put the door with the outer side down on a soft and level surface to prevent scratches.

Removing and cleaning the door glass panels

1. Remove the door.
2. Hold the door trim (B) on the top edge of the door at the two sides and push inwards to release the clip seal.
3. Pull the door trim to the front to remove it.

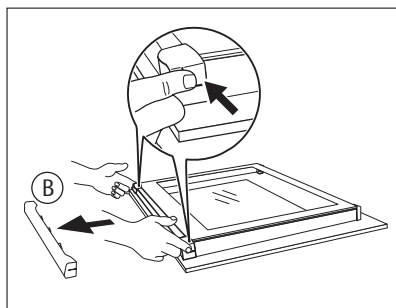

4. Hold the door glass panels on their top edge one by one and pull them up out of the guide
5. Clean the door glass panels.

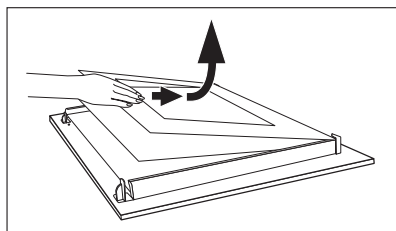

To install panels follow the procedure in reverse. Install the smaller panel first, then the larger.

WHAT TO DO IF...



WARNING!

Refer to "Safety information" chapter.

Problem	Possible cause	Remedy
The oven does not heat up	The oven is not switched on	Switch on the oven (refer to chapter "Daily use").
The oven does not heat up	The fuse in the fuse box is released	Control the fuse. If the fuse is released more than one time, refer to a qualified electrician.
The oven lamp does not operate	The oven lamp is defective	Replace the oven lamp
Steam and condensation settle on the food and in the oven cavity	You left the dish in the oven for too long	Do not leave the dishes in the oven for longer than 15-20 minutes after the cooking process ends

If you cannot find a solution to the problem yourself, contact your dealer or the service centre.

The necessary data for the service centre is on the rating plate. The rating plate is on the front frame of the appliance cavity.

We recommend that you write the data here:

Model (MOD.)

Product number (PNC)

Serial number (S.N.)

INSTALLATION



WARNING!

Refer to "Safety information" chapter.



The built-in unit must meet the stability requirements of DIN 68930.

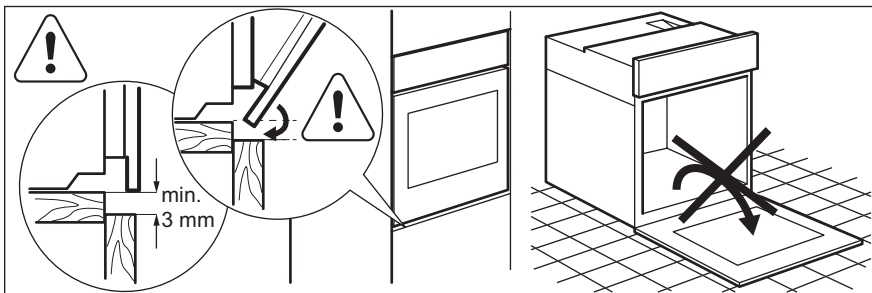

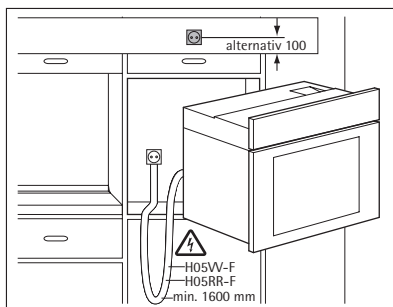
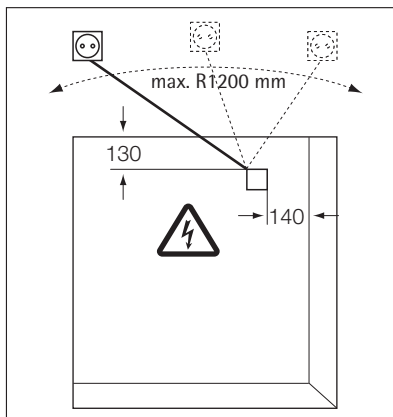
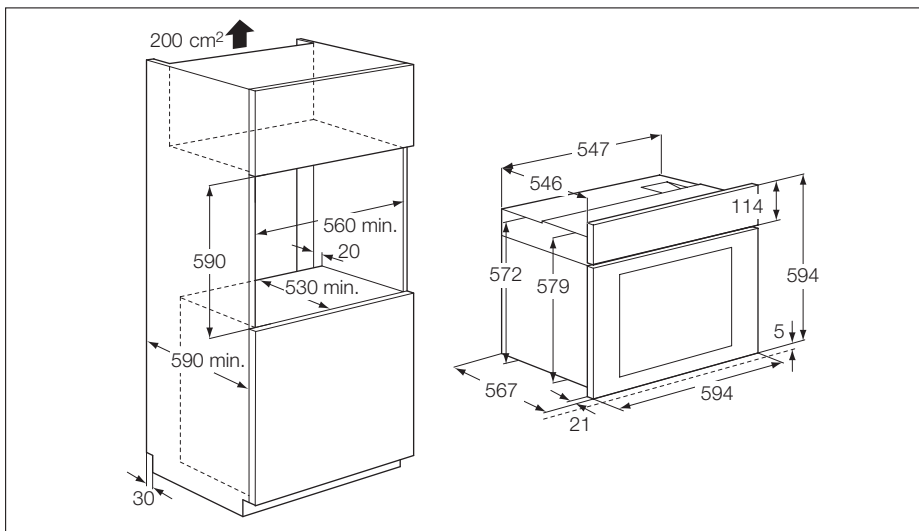

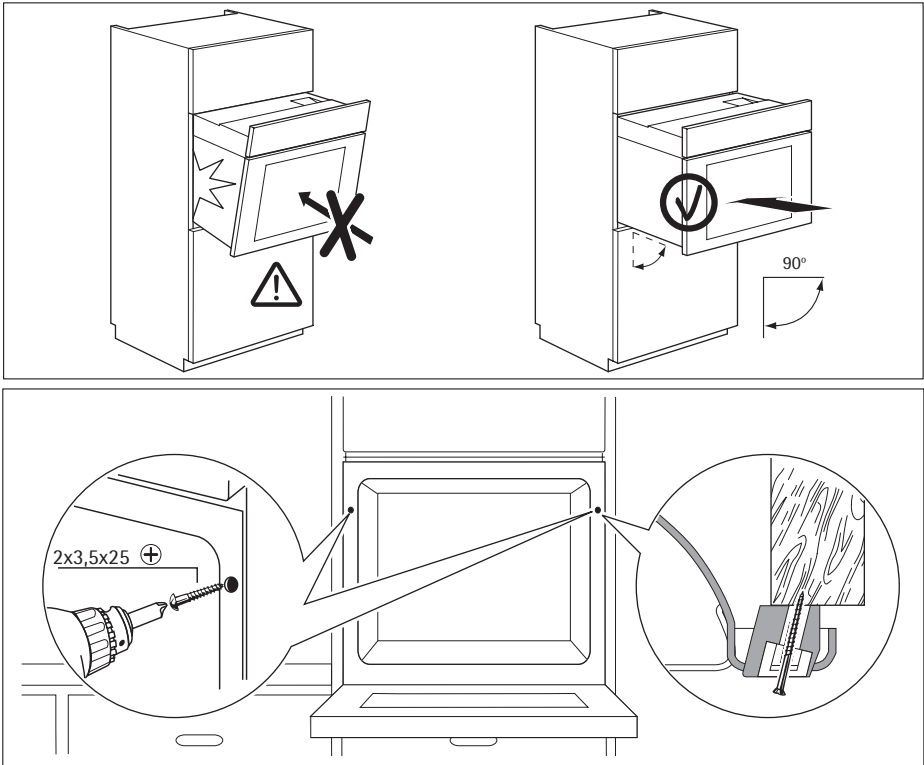

ENVIRONMENT CONCERNS

The symbol  on the product or on its packaging indicates that this product may not be treated as household waste. Instead it should be taken to the appropriate collection point for the recycling of electrical and electronic equipment. By ensuring this product is disposed of correctly, you will help prevent potential negative consequences for the environment and human health, which could otherwise be caused by inappropriate waste handling of this product. For more detailed information about recycling of this product, please contact your local council, your household waste disposal service or the shop where you purchased the product.



Packaging material

The packaging material is environmentally-friendly and recyclable. Plastic parts are marked with international abbreviations such as PE, PS, etc. Dispose of the packaging material in the containers provided for this purpose at your local waste management facility.

MAJOR APPLIANCE WARRANTY INFORMATION

Your appliance is covered by a one year limited warranty. For one year from your original date of purchase, Electrolux will repair or replace any parts of this appliance that prove to be defective in materials or workmanship when such appliance is installed, used, and maintained in accordance with the provided instructions. In addition, the glass cooktop or radiant surface element of your appliance (excluding built-in and free-standing range appliances) is covered by a two through five year limited warranty. During the 2nd through 5th years from your original date of purchase, Electrolux will provide a replacement glass cooktop or radiant surface element for your appliance which has proven to be defective in materials or workmanship when such appliance is installed, used, and maintained in accordance with the provided instructions.

Exclusions

This warranty does not cover the following:

1. Products with original serial numbers that have been removed, altered or cannot be readily determined.
2. Product that has been transferred from its original owner to another party or removed outside the USA or Canada.
3. Rust on the interior or exterior of the unit.
4. Products purchased "as-is" are not covered by this warranty.
5. Food loss due to any refrigerator or freezer failures.
6. Products used in a commercial setting.
7. Service calls which do not involve malfunction or defects in materials or workmanship, or for appliances not in ordinary household use or used other than in accordance with the provided instructions.
8. Service calls to correct the installation of your appliance or to instruct you how to use your appliance.
9. Expenses for making the appliance accessible for servicing, such as removal of trim, cupboards, shelves, etc., which are not a part of the appliance when it is shipped from the factory.
10. Service calls to repair or replace appliance light bulbs, air filters, water filters, other consumables, or knobs, handles, or other cosmetic parts.
11. Labor or in-home service costs during the additional limited warranty periods beyond the first year from your original date of purchase.
12. Pickup and delivery costs; your appliance is designed to be repaired in the home.
13. Surcharges including, but not limited to, any after hour, weekend, or holiday service calls, tolls, ferry trip charges, or mileage expense for service calls to remote areas, including the state of Alaska.
14. Damages to the finish of appliance or home incurred during transportation or installation, including but not limited to floors, cabinets, walls, etc.
15. Damages caused by: services performed by unauthorized service companies; use of parts other than genuine Electrolux parts or parts obtained from persons other than authorized service companies; or external causes such as abuse, misuse, inadequate power supply, accidents, fires, or acts of God.

DISCLAIMER OF IMPLIED WARRANTIES; LIMITATION OF REMEDIES CUSTOMER'S SOLE AND EXCLUSIVE REMEDY UNDER THIS LIMITED WARRANTY SHALL BE REPAIR OR REPLACEMENT AS PROVIDED HEREIN. CLAIMS BASED ON IMPLIED WARRANTIES, INCLUDING WARRANTIES OF MERCHANTABILITY OR FITNESS FOR A PARTICULAR PURPOSE, ARE LIMITED TO ONE YEAR OR THE SHORTEST PERIOD ALLOWED BY LAW, BUT NOT LESS THAN ONE YEAR. ELECTROLUX SHALL NOT BE LIABLE FOR CONSEQUENTIAL OR INCIDENTAL DAMAGES SUCH AS PROPERTY DAMAGE AND INCIDENTAL EXPENSES RESULTING FROM ANY BREACH OF THIS WRITTEN LIMITED WARRANTY OR ANY IMPLIED WARRANTY. SOME STATES AND PROVINCES DO NOT ALLOW THE EXCLUSION OR LIMITATION OF INCIDENTAL OR CONSEQUENTIAL DAMAGES, OR LIMITATIONS ON THE DURATION OF IMPLIED WARRANTIES, SO THESE LIMITATIONS OR EXCLUSIONS MAY NOT APPLY TO YOU. THIS WRITTEN WARRANTY GIVES YOU SPECIFIC LEGAL RIGHTS. YOU MAY ALSO HAVE OTHER RIGHTS THAT VARY FROM STATE TO STATE.

If You Need Service

Keep your receipt, delivery slip, or some other appropriate payment record to establish the warranty period should service be required. If service is performed, it is in your best interest to obtain and keep all receipts. Service under this warranty must be obtained by contacting Electrolux at the addresses or phone numbers below. This warranty only applies in the USA, Puerto Rico and Canada. In the USA and Puerto Rico, your appliance is warranted by Electrolux Major Appliances North America, a division of Electrolux Home Products, Inc. In Canada, your appliance is warranted by Electrolux Canada Corp. Electrolux authorizes no person to change or add to any obligations under this warranty. Obligations for service and parts under this warranty must be performed by Electrolux or an authorized service company. Product features or specifications as described or illustrated are subject to change without notice.

U.S.A.

1.800.944.9044

Electrolux Home Products, Inc.,
10200 David Taylor Drive
Charlotte, NC 28262

Canada

1-800-265-8352

Electrolux Canada Corp.
5855 Terry Fox Way
Mississauga, Ontario, Canada L5V 3E4



Free Manuals Download Website

<http://myh66.com>

<http://usermanuals.us>

<http://www.somanuals.com>

<http://www.4manuals.cc>

<http://www.manual-lib.com>

<http://www.404manual.com>

<http://www.luxmanual.com>

<http://aubethermostatmanual.com>

Golf course search by state

<http://golfingnear.com>

Email search by domain

<http://emailbydomain.com>

Auto manuals search

<http://auto.somanuals.com>

TV manuals search

<http://tv.somanuals.com>