



VCX™ Manager's Telephone Guide

VCX™ V7000 IP Telephony Solution
System Release 7.0

Part Number 900-0326-01 Rev AD
Published May 2006

<http://www.3com.com/>



3Com Corporation
350 Campus Drive
Marlborough, MA
01752-3064

Copyright © 2006 3Com Corporation. All Rights Reserved. No part of this documentation may be reproduced in any form or by any means or used to make any derivative work (such as translation, transformation, or adaptation) without written permission from 3Com Corporation.

3Com Corporation reserves the right to revise this documentation and to make changes in content from time to time without obligation on the part of 3Com Corporation to provide notification of such revision or change.

3Com Corporation provides this documentation without warranty, term, or condition of any kind, either implied or expressed, including, but not limited to, the implied warranties, terms, or conditions of merchantability, satisfactory quality, and fitness for a particular purpose. 3Com may make improvements or changes in the product(s) and/or the program(s) described in this documentation at any time.

If there is any software on removable media described in this documentation, it is furnished under a license agreement included with the product as a separate document, in the hardcopy documentation, or on the removable media in a directory file named LICENSE.TXT or !LICENSE.TXT. If you are unable to locate a copy, please contact 3Com and a copy will be provided to you.

UNITED STATES GOVERNMENT LEGENDS:

If you are a United States government agency, then this documentation and the software described herein are provided to you subject to the following:

United States Government Legend: All technical data and computer software is commercial in nature and developed solely at private expense. Software is delivered as Commercial Computer Software as defined in DFARS 252.227-7014 (June 1995) or as a commercial item as defined in FAR 2.101(a) and as such is provided with only such rights as are provided in 3Com's standard commercial license for the Software. Technical data is provided with limited rights only as provided in DFAR 252.227-7015 (Nov 1995) or FAR 52.227-14 (June 1987), whichever is applicable. You agree not to remove or deface any portion of any legend provided on any licensed program or documentation contained in, or delivered to you in conjunction with guide.

Unless otherwise indicated, 3Com registered trademarks are registered in the United States and may or may not be registered in other countries.

3Com and the 3Com logo are registered trademarks of 3Com Corporation. VCX is a trademark of 3Com Corporation.

Other brand and product names may be registered trademarks or trademarks of their respective holders.

CONTENTS

ABOUT THIS GUIDE

Conventions	8
Figures	8
Related Documentation	9
Comments	10

1 GETTING STARTED

VCX Telephone Overview	12
Initial Voice Mailbox Setup	13
Configuration Options	14
Additional Information Sources	14

2 VCX V7000 MANAGER'S TELEPHONE — MODEL 3103

Telephone Buttons and Controls	16
Access Buttons	19
Status Lights for Access Buttons	20
Feature Options	20
Display Panel Contrast	23

3 BASIC TELEPHONE OPERATION

Logging In to Your Telephone	26
Changing Your Password	27
Answering a Call	28
Answering a Second Call	29
Making Calls	29
Making Internal Calls	29
Redialing a Call	30
Making External Calls	30
Making a Call to a Remote Office	30

Using Unique Extensions	30
Using Site Codes	31
Class of Service Override	31
Terminating Calls	32
Using the Telephone Display Panel	32
Controlling the Volume	34
Using the Hands Free Feature	35
Using a Headset	35
Returning to the Headset After a Long Delay	36
Putting a Call on Hold	36
Music on Hold	36
Dialing a New Call While on a Call	37
Answering a New Call While on a Call	37
Transferring a Call	37
Unattended Transfer	37
Attended Transfer	38
Serial Transfer	38
Mapped Button Method	38
Serial Transfer Feature Code Method	39
Muting Calls	39
Mute Ringer	39
Activating Do Not Disturb	40

4 FEATURE CODES

Feature Code Overview	44
Feature Codes	44

5 STANDARD FEATURES

Viewing the Call Logs	52
Viewing the User Directory	52
Controlling Caller ID	53
Using the Telephone User Interface	53
Using the VCX User Interface	54
Setting up a Conference Call	54
Unannounced Conference	55
Announced Conference	55
Dropping a conference recipient	55

Camping on a Busy Extension	55
Transferring Your Phone Settings to Another Phone	56
Forwarding Calls to Voice Mail	57
Transferring a Call to Another User's Voice Mail	58
Call Waiting	58
Speed Dialing	58
Configuring Personal Speed Dial Numbers	59
Editing Personal Speed Dial Numbers	61
Dialing Personal Speed Dial Numbers	61
Dialing System Speed Dial Numbers	62
Call Forwarding	62
Call Forward No Answer	63
Call Forward Busy	63
Call Forward All	64
Call Park	64
Paging	65
Paging a Group	66
Call Pickup	66
Directed Call Pickup	67
Group Call Pickup	67
Call Pickup Interaction With Other Features	67
Silent Monitor and Barge In	68
Monitoring a Call	69
Barging In	70
Blocking Call Monitoring	70
Remote Call Forward	71
Hunt Groups	72
Hunt Group Types	74
Logging In to a Hunt Group	76
Hunt Group Interaction With Other Features	77
Viewing Hunt Group Membership and Status	78

6 USING THE VCX USER INTERFACE

Accessing the VCX User Interface	80
VCX User Interface Overview	80
Enabling Call Forwarding	83
Configuring a Call Coverage Point	85

Assigning Access Button Functions Using the VCX User Interface	86
Enabling Bridged Extensions	86
Bridged Line Interaction with Other Features	88
Do Not Disturb and Bridged Line Calls	89
Hands Free and Bridged Line Calls	90
Call Forward, Forward to Voice Mail, and Bridged Line Calls	90
Call Transfer, Call Conferencing, and Bridged Line Calls	91
Call Park and Bridged Line Calls	91
Call Pickup and Bridged Line Calls	92
Attendant Console and Bridged Line Calls	92
Hunt Groups and Bridged Line Calls	92
Message Waiting Indication and Bridged Line Calls	92
Personal Speed Dial Access Buttons	93
Logging Out	93

7 VCX ATTENDANT CONSOLES — MODEL 3105 AND COMPLEMENT ATTENDANT

VCX Attendant Console	96
Access Buttons	96
Feature Buttons	96
Printing Labels	98
Attendant Console Status Lights	99
Complement Attendant Software	100

A TELEPHONE INSTALLATION AND MAINTENANCE

Connecting the Telephone	106
Attaching and Adjusting the Articulating Support Bracket	108
Opening the 3105 Attendant Console Label Cover	111
Moving Your Telephone	111
Swapping Telephones	111
Cleaning Your Telephone	112
Troubleshooting Problems	112

INDEX

ABOUT THIS GUIDE

This guide describes how to set up and use 3Com® VCX™ telephones and consoles.

This guide is for users of the following VCX hardware and software:

- VCX 3103 Manager's Telephone
- VCX3105 Attendant Console and PC-based Self-conscious



If release notes are shipped with your product and the information there differs from the information in this guide, follow the instructions in the release notes.



CAUTION: *The 3Com telephone system operates over the Ethernet local area network (LAN), not through a traditional telephone connection. Your telephone is connected to the 3Com system through an RJ45 Ethernet connector instead of through an RJ11 telephone connection. Your telephone will not work unless it is connected correctly.*

For information about installing your telephone, see the packing sheet that came in the box with your telephone. The model number is on the underside of the telephone. Contact your administrator if you have questions about your telephone connection.

For information about the voice mail system and features, see the *IP Messaging Module User Guide - 3Com Native Interface* or the *IP Messaging Module User Guide - Traditional Interface*, depending on the Telephone User Interface (TUI) enabled for your phone.

Conventions

Table 1 and Table 2 list conventions that are used throughout this guide.

Table 1 Icons



Icon	Type	Description
		Information about important features or instructions.
		Alerts you to potential loss of data or potential damage to an application, system, device, or network.
		

Table 2 Text Conventions

Convention	Description
Screen displays	This typeface represents information as it appears on the screen
Commands	The word “command” means that you must enter the command exactly as shown and then press Return or Enter. Commands appear in bold. Example: To remove the IP address, enter the following command: SETDefault!0 -IP NETaddr = 0.0.0.0
Words in <i>italics</i>	Italics are used to: <ul style="list-style-type: none"> ■ Emphasize a point. ■ Denote a new term at the place where it is defined in the text.

Figures This guide provides figures and screen captures that contain sample data. This data may vary from the data on an installed system.

**Related
Documentation**

These 3Com documents contain additional information about the products in this release that are a part of or support the 3Com Convergence Application Suite.

The following documents are a part of the VCX IP Telephony Module:

- *VCX Installation and Maintenance Guide*
- *VCX Administration Guide*
- *VCX Basic Telephone Quick Reference Guide*
- *VCX Business Telephone Quick Reference Guide*
- *VCX Manager's Telephone Quick Reference Guide*
- *VCX Feature Codes for Analog Telephones Quick Reference Guide*
- *VCX Basic Telephone Guide*
- *VCX Business Telephone Guide*
- *VCX Manager's Telephone Guide*
- *VCX Security Guide*

The following documents are a part of the IP Messaging Module:

- *IP Messaging Module Product Overview*
- *IP Messaging Quick Reference Guide - 3Com Native Interface*
- *IP Messaging Module User Guide - 3Com Native Interface*
- *IP Messaging Quick Reference Guide - Traditional Interface*
- *IP Messaging Module User Guide - Traditional Interface*
- *IP Messaging Module Operations and System Administration Guide*
- *E-Mail Reader Application Quick Start Guide*

The following documents are a part of the IP Conferencing Module:

- *IP Conferencing Module Installation Guide*
- *IP Conferencing Module Administration Guide*
- *IP Conferencing Module User Guide*
- *Convergence Center Client User and Administration Guide*

The following documents provide information on products that support this release:

- *Enterprise Management Suite User Guide*
- *Enterprise Management Suite Getting Started Guide*
- *VCX V7111 Fast Track Installation Guide, Version 4.4*
- *VCX V7111 VoIP SIP Gateways User Manual, Version 4.4*
- *VCX V7122 SIP VoIP Gateway Installation Guide, Version 4.4*
- *VCX V7122 VoIP SIP Gateways User Manual, Version 4.4*

Comments

Send e-mail comments about this guide or about any Voice product documentation to:

`VOICE_Techcomm_comments@3com.com`

Include the following information with your comments:

- Document title
- Document part number (found on the front page)
- Page number
- Your name and organization (optional)

Example:

***VCX Manager's Telephone Guide
System Release 7.0***

Part Number 900-0326-01 Rev AD

Page 25



Please address all questions regarding the 3Com software to your authorized 3Com coordinator.

1

GETTING STARTED

This chapter provides a general description of your VCX telephone and describes the steps you must complete to use your phone.

This chapter includes the following topics:

- [VCX Telephone Overview](#)
- [Initial Voice Mailbox Setup](#)
- [Configuration Options](#)
- [Additional Information Sources](#)

VCX Telephone Overview

Your VCX telephone must be configured to work in an IP network. This means your phone must be assigned an IP address so it can communicate with other VCX phones and devices. Typically, your administrator assigns IP values, including an IP address, as part of the installation process.

During the installation process, your administrator creates an account for you. This account includes a telephone number and a voice mailbox. Your administrator also assigns a password that associates your telephone number and a voice mailbox with your account.

This chapter assumes that your administrator has either logged you in to your telephone or has given you login instructions.

- If you are logged in, the Display Panel on your phone shows the current date and time, and your extension.
- If you are not logged in, see [Logging In to Your Telephone](#).



This guide describes the features available with your telephone, such as telephone button functions, making and forwarding calls, and speed dialing. In addition, your account includes a voice mailbox. Voicemail features are provided by 3Com IP Messaging software. These features, such as listening to or sending messages, are described in the IP Messaging guide associated with your messaging system. See [Additional Information Sources](#).

The settings on your telephone, including your extension, personal settings, and system settings, remain the same even when you move your telephone from one Ethernet jack to another, as long as both Ethernet connections are part of the same network.

One of the benefits of a telephone configured with an IP address is portability. Depending on how your administrator has configured the VCX system, you may be allowed to configure another VCX phone in the system to duplicate your primary phone simply by logging in to the other phone using your password (see [Transferring Your Phone Settings to Another Phone](#)).



Your VCX telephone can provide many features. Some of these features are optional. Your administrator determines which features are available for your telephone.

Initial Voice Mailbox Setup

When a caller dials your telephone number and you are unable to answer the call, the caller hears a recording and is prompted to leave a message. Before you can listen to messages in your voice mailbox, you must record your name, a personal greeting, and change the default password you use to access your mailbox.

Your administrator will provide you with the default password for initial mailbox access. Typically, the default password is the last 4 digits of your phone number. The first time you access your voice mailbox, the system prompts you to change your password, record your name, and record a personal greeting.

Note that the password you use to access your voice mailbox is not the same password you use to log in to your telephone. When you change the default voicemail password in the following procedure, you do not change the telephone login password.

To initialize your mailbox:

- 1** Lift the handset.
- 2** Press the message button on your phone (see the chapter in this guide that describes the buttons and controls for your particular phone model).
- 3** At the password prompt, use the keypad to enter your default password.
The voice prompt system describes the initialization process and introduces the Setup Assistant function.
- 4** Follow the voice prompts to:
 - a** Enter a new password (ask your administrator for password length requirements; use digits only, * and # are invalid characters).
 - b** Record a name announcement.
 - c** Record a personal greeting.
- 5** Hang up.

Configuration Options

Simple VCX telephone operations (for example, making a call, transferring a call, and putting a call on hold) require no configuration. These operations are described in [Chapter 3](#).

Many VCX features, however, do require configuration (for example, call forwarding and speed dialing). In general, you can configure these features using one of the following methods:

- The Telephone User Interface (TUI) is a phone-based interface that allows you to manage your user account and VCX telephone by entering commands using the telephone keypad. The command used to enable or disable a feature is executed by entering a feature code. Configuration options and prompts are displayed on the telephone Display Panel. See [Chapter 5](#) for more information on using the TUI. Many options configured through the TUI require entering a feature code.
 - Basic telephone operation, such as making calls and putting a call on hold, is described in [Chapter 3](#).
 - Features that must be configured, such as speed dialing and call forwarding, are described in [Chapter 5](#).
 - Feature codes are described in [Chapter 4](#).
- The VCX User Interface is a web browser-based application that allows you to manage your user account and VCX telephone. Most of the options available through this interface are also available through the TUI. See [Chapter 5](#) for more information on using the VCX 7000 User Interface.

Additional Information Sources

You may also want to refer to the following documents in the VCX documentation set for additional information:

- *VCX Manager's Telephone Quick Reference Guide* — Provides a single-sheet reference that describes commonly used Model 3103 telephone features.
- *IP Messaging Module User Guide - 3Com Native Interface* or the *IP Messaging Module User Guide - Traditional Interface* — Provides information about the voicemail system and features available on your phone. The Guide you should reference depends on the Telephone User Interface (TUI) enabled on your phone. Ask your administrator for details.

2

VCX V7000 MANAGER'S TELEPHONE — MODEL 3103

This chapter describes the buttons, controls, and features on the 3Com® VCX™ Model 3103 Manager's Telephone.

This chapter includes the following topics:

- [Telephone Buttons and Controls](#)
- [Access Buttons](#)
- [Status Lights for Access Buttons](#)
- [Feature Options](#)

Telephone Buttons and Controls

[Figure 1](#) shows the buttons and controls on the VCX Model 3103 Manager's Telephone.

Figure 1 VCX Model 3103 Manager's Telephone

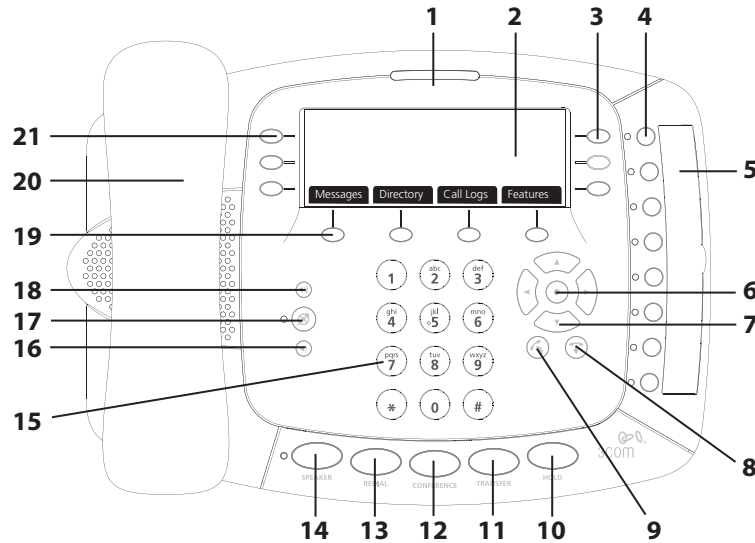

- 1 Message Waiting Indicator (MWI)** — When lit, indicates that you have at least one unreviewed message (voice, e-mail, or fax) in your mailbox. This indicator also flashes when your telephone rings.
- 2 Display Panel** — Displays telephone status messages, Caller ID information (if enabled), and the number of new messages (voice, e-mail, and fax) that you have in your mailbox. You can also use the display panel to access the following options:
 - **Messages** — Allows you to access messages stored in your mailbox.
 - **Directory** — Displays a directory of the people in your organization. You can search the directory, select a user, and make a call.
 - **Call Logs** — Displays a list of received, missed, and placed calls. You can select and return a call, or clear a call from the log.
 - **Features** — Provides access to features such as call forwarding, call park, password change, and hunt group login. See [Feature Options](#) for more information.

You can manage items in the Display Panel with the buttons to the right (see **3**), the left (see **21**), and below (see **19**) the panel.

- 3 Right Buttons** — Invoke the action list for a corresponding call. When a phone call is associated with the button, the button opens or closes a call action list. Scroll through the list and select an action by pressing the corresponding **right** button or press the **Select** button (see **6**).

When there is a list option (not a call) associated with the button, the button activates the option.

Bottom Right (Advanced Settings) Button — provides users access to configure the phone to the call processor server. Settings include:

- **Set Primary PBX IP** — sets the primary IP address of the call processor server
- **Set Secondary PBX IP** — sets the secondary IP address of the call processor server
- **Set Dialing Domain** — sets the dialing domain for your phone. The default dialing domain is 000.000.000.000.
- **Set My Phone Number** — set the phone number for the phone
- **Set My Password** — sets the user password
- **Change Login Status** — sets the login status associated with the system.
- **Set External IP** — sets the IP address of the Media Gateway for the external telephone network
- **View Debug Events** — used by network administrators

Refer to the *VCX System Administrator's Guide* for details on how to use the Advanced Settings feature.

- 4 Access Buttons** — Your administrator assigns default functions for these buttons and may allow you to reprogram a button's function (for example, create more personal speed dial buttons). See [Access Buttons](#) and [Status Lights for Access Buttons](#).
- 5 Label Area** — Provides space for inserting a label that describes the function of each Access button. See [Printing Labels](#).
- 6 Select Button** — Selects the highlighted item in a list on the Display Panel.
- 7 Scroll Buttons (Up, Down, Left, Right)** — Moves items up and down in the Display Panel if there are more than three calls or list items to be displayed. Arrows in the display show if there are more calls or items above or below those displayed.

The left and right buttons move you to the top or bottom of a list or move the cursor left or right when you enter data.

- 8 Release Button** — Hangs up the current active call.
- 9 New Call Button** — Initiates a new telephone call.
- 10 Hold Button** — Places a caller on hold. See [Putting a Call on Hold](#).
- 11 Transfer Button** — Sends the currently active call to another telephone. See [Transferring a Call](#).
- 12 Conference Button** — Establishes a single call with up to three additional internal parties, external parties, or both. See [Setting up a Conference Call](#).
- 13 Redial Button** — Redials the last telephone number or extension that you called. See [Redialing a Call](#).
- 14 Speaker Button** — Enables you to use the speaker phone feature. Press the Speaker button before you dial the call, when your telephone is ringing, or while a call is in progress. To turn the speaker phone off and continue the conversation, pick up the handset.
- 15 Telephone Key Pad** — Enables you to dial calls, enter Feature Codes, or enter other passwords and numbers required for features.
- 16 Volume Down** — Lowers the volume of the ringer, the speaker, the handset, or the headset. See [Controlling the Volume](#).
- 17 Mute Button** — Enables you to prevent callers from hearing what you are saying during a telephone call, although you can still hear them. See [Muting Calls](#).
- 18 Volume Up** — Raises the volume of the ringer, the speaker, the handset, or the headset. See [Controlling the Volume](#).
- 19 Bottom Soft Buttons** — There are four soft buttons that activates the tabbed command displayed above a corresponding button. The commands change according to context. Possible options include access to messages, directories, call logs, and feature dialogs.
- 20 Handset**
- 21 Left Line Buttons** — There are three line buttons that control the call displayed beside the corresponding button. Up to three calls can be displayed at one time. Press a left line button to answer an incoming call, rejoin a call on hold, and select it for other action. If there is no call associated with a line button, press it to start a new call.

Access Buttons

[Figure 2](#) shows the 8 Access buttons on the VCX Model 3103 Manager's Telephone.

The buttons are assigned default functions (described in the following list) by 3Com. Your administrator can change these defaults and may allow you to reprogram some or all of the button functions. Ask your administrator for more information.

You can view button assignments through the Telephone User Interface (see [Feature Options](#)) or change button assignments through the VCX User Interface (see [Assigning Access Button Functions Using the VCX User Interface](#)).

Figure 2 VCX Model 3103 Access Buttons

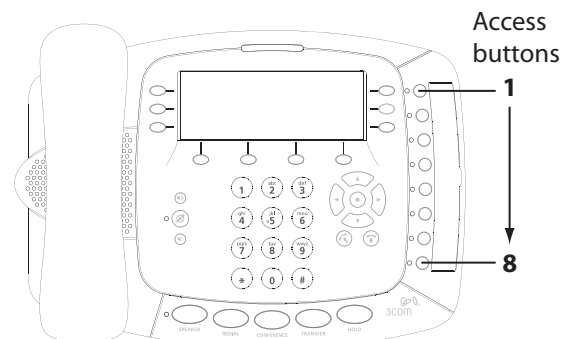

Access buttons have these default settings:

- 1 **Do Not Disturb** — Enables the Do Not Disturb feature. See [Activating Do Not Disturb](#).
- 2 **Call Forward** — Allows you to forward calls to different destinations. See [Call Forwarding](#).
- 3 **Call Park** — Allows you to place a call in a “holding pattern” and retrieve it from any other telephone in the system. See [Call Park](#).
- 4 **Personal Speed Dial 1** — See [Speed Dialing](#).
- 5 **Personal Speed Dial 2**
- 6 **Personal Speed Dial 3**
- 7 **Personal Speed Dial 4**
- 8 **Personal Speed Dial 5**

Status Lights for Access Buttons

An Access button that is set up for incoming and outgoing calls indicates the status, as shown in [Table 3](#).

Table 3 Status Lights for Access Buttons

	The line is
Off	Available for use
Steady	In use

Feature Options

Your Manager's phone provides a full range of features. You can access some of these features (for example, call transfer) by pressing a dedicated button. These features, and basic phone operations such as making and answering calls, are described in [Chapter 3, Basic Telephone Operation](#).

You can access some Manager's phone features by pressing the **Features** soft button, as shown in [Figure 3](#). You can then enable a feature using either of the following methods:

- 1 Press the **Features** soft button.
- 2 Enter the three-digit feature code on the keypad (see [Feature Codes](#)).
- 3 Enter any additional values following display panel prompts.

Or

- 1 Press the **Features** soft button.
- 2 Scroll to the feature by pressing the **Scroll Down** () button.
- 3 Press the **Select** soft button.
- 4 Enter any additional values following display panel prompts.

Figure 3 Features Soft Button



The following list describes the Manager's phone features. See [Chapter 5, Standard Features](#) for detailed information.

- **Anonymous All**— Controls whether your Caller ID (your name and extension) is shown on the Display Panel of the telephone receiving your call. See [Controlling Caller ID](#).
- **Anonymous Next** — Restricts Called ID information from displaying only on the next call that you make.
- **Call Forward All** — Allows you to redirect incoming calls to another destination unconditionally. See [Call Forwarding](#).
- **Call Forward Busy** — Allows you redirect incoming calls to another destination when your phone is busy. See [Call Forwarding](#).
- **Call Forward No Answer** — Allows you redirect incoming calls to another destination when your phone rings but is not answered. See [Call Forwarding](#).
- **COS Override** — Class of Service (COS) Override allows you to apply the features of your own 3Com telephone temporarily to another 3Com telephone on the same local network.
- **Do Not Disturb (DND)** — Forces incoming calls to go immediately to the call coverage point set by you or your administrator. See [Activating Do Not Disturb](#).

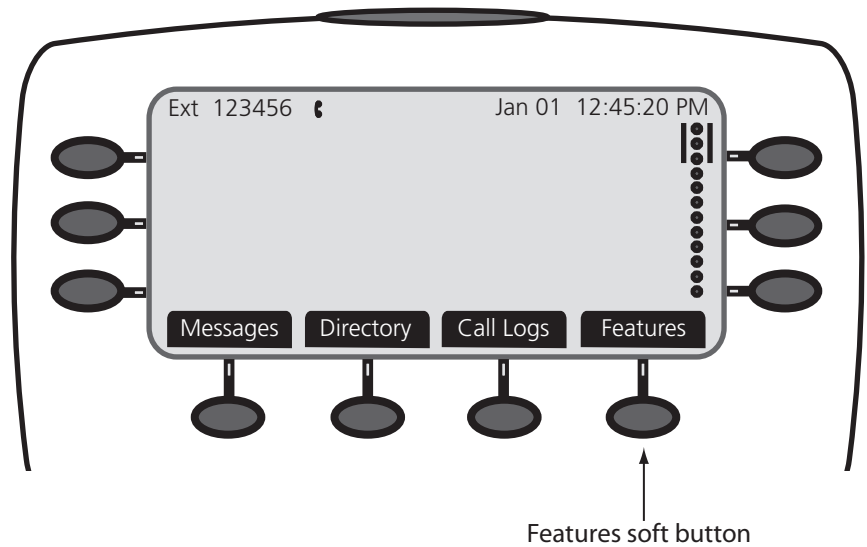
- **Forward to Mail** — Forwards incoming calls to your voice mail. See [Forwarding Calls to Voice Mail](#).
- **Handsfree (toggle)** — When enabled, you can use your phone as an intercom. You can answer internal (intercom) calls without picking up the handset. When you receive an internal call, your telephone sounds a tone and activates the speaker phone.
- **Hunt Group Login Enabled** — When enabled by your administrator, allows you to log in to, and out of, a Hunt Group. See [Hunt Groups](#).
- **Last Number Redial** — Redials the last telephone number or extension that you called.
- **Pickup, Directed** — Allows you to answer a call ringing on another specific phone. See [Directed Call Pickup](#).
- **Speed Dials: Personal** — Allows you to create up to nine internal or external personal speed dial numbers.
- **Speed Dials: System** — Displays commonly used internal or external speed dial numbers that the system administrator assigns.
- **Supervisory Monitoring** — When enabled by your administrator, this feature allows you to monitor another user's phone calls. See [Silent Monitor and Barge In](#).
- **User Configurations** — Except for adjusting the display panel contrast, this feature is for system administrator use **only**.
- **Version** — Displays the current phone software version.

Display Panel Contrast

You can adjust the Display Panel contrast as one of the User Configuration Features.

To adjust the contrast:

- 1 Press the **Features** soft button.
- 2 Scroll to **User Configuration** and press **Select**.
- 3 Scroll to **Modify Display** and press **Select**.
- 4 Press **Select** to choose **Set Contrast**.
- 5 Change contrast using the left and right scroll buttons.
- 6 Press **Exit** when you have finished.



Other User Configuration items should only be changed with the advice of your administrator.

3

BASIC TELEPHONE OPERATION

This chapter describes how to use the basic telephone functions available on all VCX telephone models and includes the following topics:

- [Logging In to Your Telephone](#)
- [Answering a Call](#)
- [Making Calls](#)
- [Terminating Calls](#)
- [Using the Telephone Display Panel](#)
- [Controlling the Volume](#)
- [Using the Hands Free Feature](#)
- [Using a Headset](#)
- [Putting a Call on Hold](#)
- [Transferring a Call](#)
- [Muting Calls](#)
- [Mute Ringer](#)
- [Activating Do Not Disturb](#)

Logging In to Your Telephone

Your administrator assigns an extension (telephone number) and initial password to your phone.

If you hear a dialtone and the Display Panel on your phone shows the date, time, and a telephone extension, you are logged in and can make calls:

Extension: 1001 Feb 17 08:12:00

Note that your administrator initially determines the format for the date and time display. You can change this format (and time zone location of your phone) through the VCX User Interface. See [VCX User Interface Overview](#) and the VCX User Interface online Help.

If you do not hear a dialtone and the Display Panel on your phone shows the following information, you are not logged in and cannot make calls:

Use Program btn to login
Logged out from PBX

To log in to your phone:

- 1 Press the **bottom right** soft button (Advanced Settings) + **6** (Change Login Status), and then press the **Select** soft button.
- 2 Enter your password and press **#**.

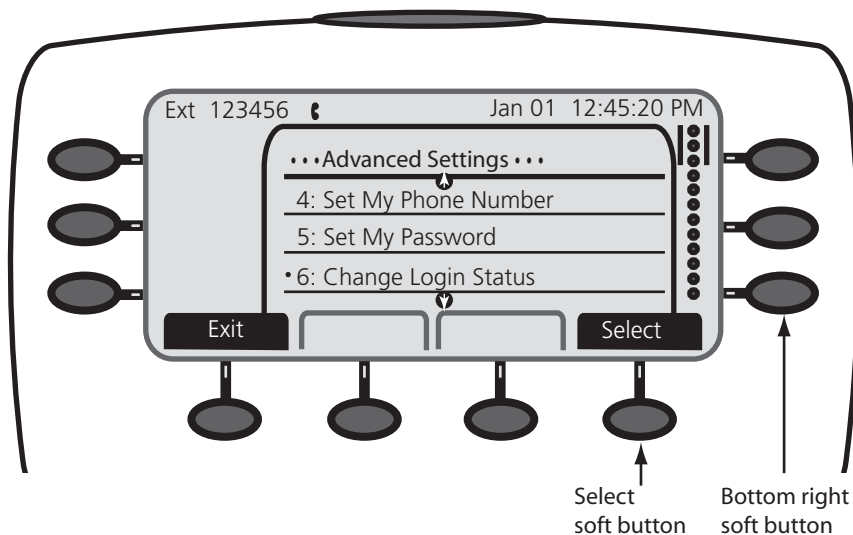

If the password you entered is associated with the phone extension, you are logged in.

If the Display Panel alternately shows the following information, the password you entered is not associated with the phone extension or the extension has not yet been assigned to the phone:

Invalid number/password:

Then:

Unable to contact PBX

Logged out from PBX

In this case, use the following steps to log in to your phone:

- 1 Press the **bottom right** soft button (Advanced Settings) + **4**.

The Display Panel shows:

Local Phone Number:

- 2 Enter your extension and press **#**.

If the Display Panel shows a previously assigned number that you want to replace, press the Delete button under the Display Panel to move the cursor back one space. Repeat as necessary and then enter your extension and press **#**.

The Display Panel shows:

Enter Password:

- 3 Enter your password and press **#**.

Alternatively to set a password locally, you can use the Password Stored Locally feature code (434) by entering the **bottom right** soft button (Advanced Settings) + **5**, then enter the password. You can use this method in place of step 1 above. See [Chapter 4](#) for information on feature codes.

Changing Your Password

You can change your password through the VCX User Interface (see [Chapter 6](#)). This changes your password on the VCX call processor. However, your password is also stored locally on your telephone. Changing your password through the VCX User Interface does *not* change the password stored on the phone. You must use the Telephone

User Interface (TUI) and change the local password to match the password stored on the call processor by following these steps:

- 1 Press the **bottom right** soft button (Advanced Settings) + **5**.

The Display Panel shows:

Enter Password:

- 2 Enter your new password and press **#**.

The VCX call processor periodically communicates with each VCX telephone. If you change your password through the VCX User Interface but do not change it through the TUI, the VCX call processor detects a password mismatch and logs you out. If this happens, follow steps 1 and 2 to log in.

Answering a Call

To answer an incoming call, lift the handset.

Alternatively, you can press the **Speaker** button. If you have enabled Handsfree Active on Intercom, you can simply speak to answer internal calls.

If your phone includes multiple access lines, press the Access button for the line on which the new call is arriving (the light next to the button will be flashing).

If you have multiple calls, press the **left line** soft button for the line on which the new call is arriving.

The Display Panel can display up to ten active calls, but only three can be visible on the display. To access active calls that are not visible, use the scroll down button. If the Display Panel contains ten active calls and you have a new incoming call, it is forwarded to your voicemail.

Unanswered calls are sent to either your call coverage point which, by default, is your voice mailbox or your configured call forwarding destination. See [Configuring a Call Coverage Point](#) or [Call Forwarding](#).

Answering a Second Call On 3Com Manager's Telephones, when a new call arrives while you are on a call:

- 1 Press the **Left** soft button next to the new call on the display. You are connected to the new call. The current call hangs up.
- 2 To return to the earlier call, you must redial the number.

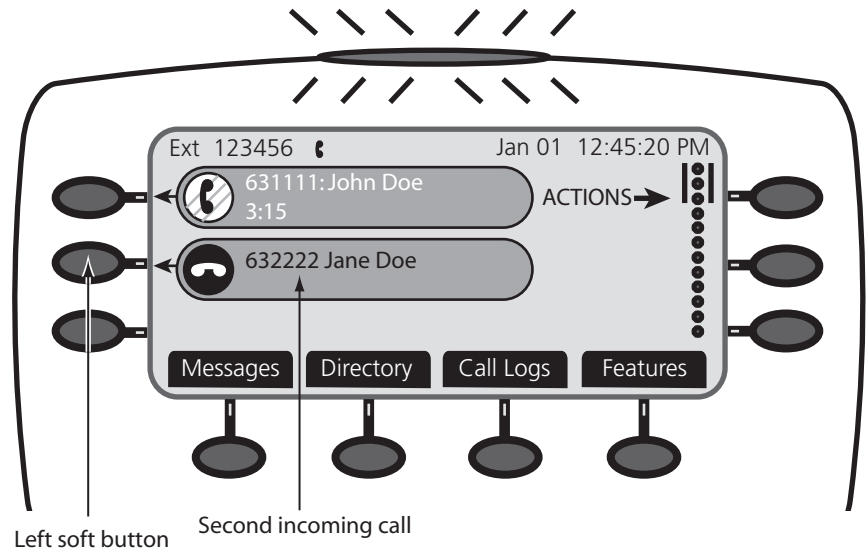

Making Calls

This section describes standard dialing features.



The VCX administrator can configure calling restrictions for some, one, or all the phones at a site. These restrictions may limit the outbound calls (external or to another company site) a phone can make. Ask your administrator if any calling restrictions have been implemented on your phone system.

Making Internal Calls To dial an internal call:

- 1 Pick up the handset. Alternatively, you can press the **Speaker** button or press the **New Call** button. If no call is associated with one of the **Left** buttons, you can press it to access a new line. You hear the dial tone.
- 2 Dial the extension. Alternatively, you can use the Display Panel to find and dial the name of the person whom you want to call in the user directory, call logs, or a speed dial list.

- 3 When you complete the call, hang up the handset. If you pressed the **Speaker** button, press it again to end the call. Or you can press the **Release** button.

Redialing a Call To redial a number on a 3Com Manager's Telephone:

- Pick up the handset and press **Redial** to dial the most recent number that you called.
- Use the Call Logs on the display panel to redial a recently missed, answered, or dialed call.

Making External Calls To dial an external call:

- 1 Pick up the handset. Alternatively, on 3Com Manager's Telephones, you can press the **Speaker** button, or you can press the **New Call** button. If no call is associated with one of the **Left** buttons, you can also press it for a new line. You hear the dial tone. If necessary, dial the number required to access an external line (for example, 9). If one of the Access buttons is configured to access an external line directly, you can press that button.
- 2 Dial the number. Or use the display panel on a 3Com Telephone to scroll to Placed Calls, Received Calls, or Missed Calls, or a personal or system-wide speed dial number. If you have programmed one of the One-Touch buttons, press that button.
- 3 When you finish speaking, hang up the handset. If you pressed the **Speaker** button, press it again to end the call.

Making a Call to a Remote Office

You can dial calls between sites in your organization that are separated geographically but that are linked by a Wide Area Network (WAN) connection. Each site must have an VCX system. Typical configurations are described in the next sections.

Using Unique Extensions

In some companies with geographically separated offices, everyone in the entire organization has a unique telephone extension. Whenever you make a call to an extension that is not located at your own site, your VCX system sets up a connection to the VCX system at the other extension's site.

For example, suppose a company has three offices:

- Phones at the Chicago office use an extension range from 1000 through 1999.
- Phones at the Atlanta office use an extension range from 2000 through 2999.
- Phones at the Dallas office use an extension range from 3000 through 3999.

In this example, to call a user in Dallas, a user in Chicago dials a Dallas extension (3000 through 3999). The dial plan on the Chicago VCX system sets up the necessary connection to the Dallas VCX system and then to the extension at that site.

Using Site Codes

In some companies with geographically separated offices, phone extensions may not be unique. If some users have overlapping telephone extensions, your administrator can configure your telephone system to require site codes that you must use to dial people at remote offices. Your administrator chooses the site codes for your system. In this case, you dial a site code first, followed by the extension at the site.

For example, suppose a company has three offices:

- Phones at the Chicago office use an extension range from 1000 through 3999. The site code for Chicago is 61.
- Phones at the Atlanta office use an extension range from 1000 through 3999. The site code for Atlanta is 62.
- Phones at the Dallas office use an extension range from 1000 through 3999. The site code for Dallas is 63.

In this example, to call someone in Atlanta, a user in Chicago dials the site code 62 and then the appropriate extension (1000 through 3999). To reach a user in Dallas, a user in Chicago dials 63 and then the appropriate extension (1000 through 3999). The site code prevents conflicts between the remote extension number and a duplicated extension number at the local site (Chicago).

Class of Service Override

The Class of Service Override feature allows you to apply the capabilities of your own VCX telephone *temporarily* to another VCX telephone on the same local network.

For example, the telephone in a conference room may be configured to prevent long-distance telephone calls. You may, however, need to place a long-distance call during a meeting. If the permissions included with the Class of Service on your phone allow long-distance calling, you can use the Class of Service Override feature to apply your phone features to the conference room phone for one call only.

To activate the one-call-only Class of Service Override for a Manager's phone:

- 1 Press the **Features** soft button.
- 2 Scroll to the **COS Override** feature.
- 3 Press the **Select** soft button. The display panel displays `COS Override on` for a few seconds.
- 4 Enter the COS number (your phone extension) and press **#**.
- 5 Enter the COS password (your telephone password) and press **#**.
- 6 When you hear the dial tone, dial the destination telephone number.



When you use Class of Service (CoS) Override, any reports that are generated on the VCX system indicate that the CoS features of your own VCX telephone were applied temporarily to the telephone on which you made the call.

Terminating Calls

You can terminate a call (hang up) by replacing the handset. Alternatively, depending on your phone model, you can press the **Release** button, or if the call is on Speaker, turn the Speaker off by pressing the **Speaker** button.

Using the Telephone Display Panel

The Display Panel shows the current date and time, and your extension number. It can also show features that you have enabled. For example, if you are logged in to a hunt group, the Display Panel shows `hunt group login enabled`.

The Display Panel can also list telephone status messages, Caller ID information (if enabled), and the number of new messages (voice, e-mail, and fax) that you have in your mailbox.

The list of new messages in the Display Panel depends on the status of each message. A new message can be:

- **Unreviewed** — An unreviewed message has never been listened to or acted upon (saved or deleted).
- **Reviewed** — A reviewed message has been listened to but has not been acted upon (saved or deleted). A message may reach this state if you listen to the message and then hang up.

The Display Panel shows the number of messages in your mailbox (and the MWI is lit) *only* if you have at least one unreviewed message. If you review the last new message and do not act on it, the Display Panel shows the date and extension, and MWI is off. If your mailbox then receives a new message, the Display Panel shows the following (and MWI is lit): 2 MSGS 1 New. The 2 MSGS include the just received new, unreviewed message and the other message which is new but reviewed. The 1 New indicates the just received new, unreviewed message.

The Display Panel also shows the number of missed calls. Missed calls include unreviewed messages in your mailbox and any other calls that you did not answer. For example, you can configure your default call coverage point to be no coverage. In this case, if you do not answer a call, when the call terminates the caller hears a busy tone and the call is not forwarded or sent to your mailbox. The Display Panel on your phone shows Missed 1. If you press the **Call Logs** soft button below the Display Panel, you can scroll through the list of missed calls and to show you the name of the calling party. Press the **Select** soft button to automatically dial the listed extension.

You can also use the Display Panel to view or enable the following features:

- **Call History** — Displays logs of your recent missed, answered, and dialed calls. See [Viewing the Call Logs](#).
- **User Directory** — Displays a directory of the people in your organization. See [Viewing the User Directory](#).
- **Speed Dial** — Displays configured speed dial numbers. See [Speed Dialing](#).
- **Call Features** — Displays the list of telephone features (note that some features may be disabled by your administrator). See [Feature Options](#).

- **Advanced Settings** — Configures network parameters, sets your phone password and changes your login status.



CAUTION: *Network parameter options are for administrator use only. Unauthorized changes to network parameters will disconnect your phone.*

Controlling the Volume

Use the **Volume Control** buttons to raise or lower the volume of the ringer, handset, or speaker.



Adjusting the volume control of one device DOES NOT affect the volume control of the other devices. For example, lowering the volume of the speaker has no effect on the handset volume. Changes you make to any device remain in effect if you reset the phone to its default settings.

- **Ringer Volume** — To raise or lower the volume of the ring, press the up or down **Volume Control** button repeatedly *while your telephone is ringing*, until the volume is at the level that you prefer.
- **Handset Volume** — To raise or lower the volume of the dial tone and the voice level of your callers, lift the handset then press the up or down **Volume Control** buttons repeatedly until the volume is at the level you prefer. You can change the volume during a conversation or by listening to the dial tone.
- **Headset Volume** — During a call, press the up or down **Volume Control** buttons repeatedly until the volume is at the level you prefer.
- **Speaker Volume** — To raise or lower the volume of the speaker, press the **Speaker** button and then press the up or down **Volume Control** button repeatedly until the volume is at the level you prefer. You can change the volume during a conversation or by pressing **Speaker** and listening to the dial tone.

When you press a **Volume Control** button, the Display Panel shows the volume setting as a series of dark vertical bars. Repeatedly pressing a **Volume Control** button raises the volume (increases the number of displayed bars) or lowers the volume (decreases the number of displayed bars).

Using the Hands Free Feature

You can use your phone as an intercom. You can answer *internal* (intercom) calls without picking up the handset. When you receive an internal call, your telephone sounds a tone and activates the speaker phone.

An external call (a call from outside your local call processor) rings to your telephone as usual.



If your telephone is part of a bridged extension, see [Hands Free and Bridged Line Calls](#) for additional information.

To enable the Hands Free feature on a Manager's Telephone:

- 1 Press the **Features** soft button.
- 2 Scroll to **Handsfree**.
- 3 Press **Select**.

To cancel Handsfree:

- 1 Press the **Features** soft button.
- 2 Scroll to **Handsfree**.
- 3 Press **Select**.

You can also enable and disable Hands Free by using Feature Code 100. See [Feature Codes](#).

Using a Headset

The Model 3103 Manager's telephone has a headset jack located on the underside of the telephone.

To prepare the headset for all calls:

- 1 Plug the headset connector into the headset jack on the underside of the telephone.
- 2 Log into the VCX User Interface and select **My Extensions** and then select the **Button Mappings** tab.
- 3 Change the phone type to *3103 Manager Phone* and then click **Select**.
- 4 Assign one of the access buttons to **Headset**. Click **Save**.
- 5 On the 3103 phone, press the **Headset** access button you assigned.
- 6 Verify that the indicator light next to the **Headset** button comes on.

To answer a call when you are using the headset:

- 1 Put the headset on. When a call comes in, press the left soft button associated with the incoming call. You are connected to the call.



The handset can be either on hook or off hook.

- 2 To end a call when you are using the headset, press the **Release** button on the telephone.

Returning to the Headset After a Long Delay

Certain brands of headsets enter a power-saving mode that prevents the telephone from ringing for one or more calls when *both* of these conditions are true:

- The headset amplifier buttons for **Mute** and **On** are both set to **On**.
- The handset is off the phone for a long time (for example, overnight).

It may take a few minutes for your headset to return from the power-saving mode to the active mode when calls first come in, so your telephone may not ring until the headset has returned to active mode, and you may miss a call.

If you plan to not use the headset for a long time, 3Com recommends that you set the mute and headset buttons on the amplifier to **Off** and hang up the handset on your telephone. When you are ready to receive calls again, set up the headset for receiving calls:

- 1 Pick up the handset on your telephone and set it on your desk.
- 2 Put on the headset.
- 3 On the amplifier, set the headset button to **On**.

Putting a Call on Hold

To put a call on hold:

- 1 Press the **Hold** button. Or press the **Right** button corresponding to the call for the Actions menu, scroll to **Hold**, and press **Select**.
- 2 To return to the call, press the corresponding **Left** button. Use the scroll buttons to locate the call if necessary.

Music on Hold

If configured by the administrator, callers on hold hear music while they wait.

Dialing a New Call While on a Call

You can put a call on hold, dial a new call, and toggle between the two calls:

- 1 Press the **Hold** button. Or press the **Right** button corresponding to the call for the Actions menu, scroll to **Hold**, and press **Select**.
- 2 Press an **Access** button, the **New Call** button, or the **Left** button to choose a new line.
- 3 When you hear dial tone, dial the second call.

Answering a New Call While on a Call

You can put your current call on hold, answer a second call, and then toggle between the two calls:

- 1 Press **Hold** and then the **Left** soft button next to the new call on the display. You are connected to the new call. The current call is put on hold.
- 2 To return to the earlier call, press **Hold** and the **Left** soft button corresponding to the earlier call on the display.

Transferring a Call

When you are on a call, the Transfer feature allows you to send the call from your telephone to any other internal line. For unattended or attended transfers, if your call permissions allow, you can send the call to an external line.



If your telephone is part of a bridged extension, see [Call Transfer, Call Conferencing, and Bridged Line Calls](#) for additional information.

You can also transfer a call to another subscriber's voice mail. See [Transferring a Call to Another User's Voice Mail](#).

Unattended Transfer

In an unattended transfer, you transfer the call without notifying the recipient. You can either use the **Transfer** button or the transfer feature code:

- 1 While on a call, press **Transfer**. The call is placed on hold, you hear a dial tone, and the system prompts you enter a destination number.
- 2 Dial the number to which you want to transfer the call or choose the number from the Directory or Speed Dial lists.
- 3 Hang up.

The call is disconnected as soon as the transfer starts, which frees up your line. If the transfer cannot be completed:

- The call is forwarded to the called party's call coverage point (by default, voice mail; see [Configuring a Call Coverage Point](#)).
- If the called party's default call coverage point is No Coverage, the call is returned to (rings back at) your extension. If you are unavailable, the call is forwarded to your call coverage point.

Attended Transfer In an attended transfer, you announce the call to the recipient. You can either use the **Transfer** button or the transfer feature code.

To announce a transfer:

- 1 While on a call, press **Transfer**. The call is placed on hold, you hear a dial tone, and the system prompts you enter a destination number.
- 2 Dial the extension number to which you want to transfer the call or choose the number from the Directory or Speed Dial lists.

The VCX call processor dials the call.

- 3 When the recipient answers, announce the call. Note that, at this point you cannot return to the original caller.
 - If the recipient wants to take the call, press **Transfer** or press the **Complete** soft button. Hang up.
 - If the recipient does *not* want to take the call, press the **Release** button. The call you tried to transfer is now on hold. Return to the original caller.

Serial Transfer A serial transfer is like an unattended transfer except that when the destination hangs up at the end of the call, the caller rings back to you as the attendant who made the transfer. With your help, the caller can make a single call to the organization and make a series of internal connections with a series of transfers. You can either use a mapped button on the Attendant Console or the serial transfer feature code:

Mapped Button Method

- 1 Press the mapped Attendant Serial Calling button on the Attendant Console.
- 2 Press the button mapped to the called party's extension on the Attendant Console.
- 3 Press the mapped Attendant Serial Calling button again on the Attendant Console to complete the call.

Serial Transfer Feature Code Method

- 1 While on a call, press **Feature + 471**. The call is placed on hold, you hear a dial tone, and the system prompts you to enter a destination number.
- 2 Dial the number to which you want to transfer the call or choose the number from the Directory or Speed Dial lists, and then press **#** to complete the call.
- 3 Hang up.

When the destination phone hangs up, the caller returns to you.

Serial transfers:

- Apply to a single transfer. Repeat for subsequent transfers even for the same caller.
- Can be mapped to a button on an Attendant Console.
- That cannot be completed return directly to the attendant.
- If the calling party reaches the called party's voice mailbox, the calling party can press **99** to return to the attendant.

Muting Calls

You can prevent callers from hearing you by turning off the telephone's microphone when you are using the handset or headset, or when your telephone is in speaker phone mode.

To mute your phone:

- 1 While you are on a call, press **Mute**. The light next to the **Mute** button comes on. Callers cannot hear you.
- 2 To turn this feature off, press **Mute**.

Mute Ringer

You can prevent the phone's ringer from ringing by enabling this feature. By default, the phone's ringer is enabled (feature disabled). You can enable or disable the phone's ringer at any time while either on the phone or on-hook, but the change takes effect on the next incoming call.

All non-ringer tones are unaffected. All ring tones, such as, internal domain, external domain, and anonymous tones are affected for all primary, bridge, and hunt-group calls. A user with a phone on hands-free hears the hands-free tone. A user that receives a page hears the page tone.

If the VCX system or the phone reboots or is upgraded with new software, the ringer resets to the default ringer enabled (feature disabled) mode.

To mute the phone ringer:

- 1 Press **Feature + 489**. The LCD displays:
Ringer is now muted.
- 2 To clear the display, press the **Clear** soft button. The next time you receive an incoming call, the ringer is muted.
- 3 To turn this feature off, press **Feature + 489** again. The LCD displays:
Ringer is now enabled.
- 4 To clear the display, press the **Clear** soft button.

Activating Do Not Disturb

When you enable Do Not Disturb, incoming calls immediately go to the call coverage point set by you or your administrator. The default call coverage point is your voice mailbox. The call coverage point is set through the VCX User Interface (see [Chapter 6](#)).

When your telephone is in Do Not Disturb mode:

- An incoming call does not cause your phone to ring. If you are logged in to multiple phones using the same phone number and one of the phones enables Do Not Disturb, the feature applies to all phones—an incoming call will not ring on any of the phones.
- You can use the phone to dial outgoing calls.
- If you enable Do Not Disturb while one or more calls are ringing, the pending calls are sent to your call coverage point and Do Not Disturb is enabled for all subsequent calls.
- If you are a Hunt Group member and you enable Do Not Disturb, personal (non-Hunt Group) calls go to your call coverage point. However, Hunt Group calls always ring on a member's phone, regardless of the Do Not Disturb setting.



If your telephone is part of a bridged extension, see [Do Not Disturb and Bridged Line Calls](#) for additional information.

To activate Do Not Disturb:

- 1** Open the **Features** tab, then scroll down the list of features and select **Do Not Disturb**.

Your telephone is now in Do Not Disturb mode. The display panel shows DND.

- 2** To disable Do Not Disturb mode, repeat step **1**. The **DND** message disappears from the display panel.

4

FEATURE CODES

This chapter describes how to use VCX feature codes on a VCX telephone to enhance the operation of your phone. A feature code is a sequence of numbers you enter on the telephone keypad to enable a feature that is not mapped to a button.

This chapter includes the following topics:

- [Feature Code Overview](#)
- [Feature Codes](#)

Feature Code Overview

Some common telephone features are mapped to buttons (**Hold**, for example). However, the number of buttons varies on each model of VCX phone. Furthermore, the number of VCX features exceeds the number of buttons available on any phone. Feature codes allow the VCX telephone feature set to be available to all VCX phones, regardless of the number of buttons on the phone.

Each feature is assigned a unique three-digit feature code. You can invoke a feature by entering the numeric code assigned to a particular feature. For example, you can use a feature code to enable call forwarding and specify a destination number.

You can access all Manager's phone features by pressing the **Features** soft button. You can then enable a feature using either of the following methods:

- 1 Press the **Features** soft button.
- 2 Enter the three-digit feature code on the keypad (see [Feature Codes](#)).
- 3 Enter any additional values following display panel prompts.

Or

- 1 Press the **Features** soft button.
- 2 Scroll to the feature.
- 3 Press the **Select** soft button.
- 4 Enter any additional values following display panel prompts.

Feature Codes

[Table 4](#) lists the features that you can control with feature codes. Features are listed alphabetically and include the required feature code syntax and, in most cases, a reference for more information. In the syntax, the notation `<parameter>` represents a variable that you must supply, for example, a telephone extension.

Table 4 VCX Feature Codes Alphabetical by Feature or Task

Feature	Feature Code Entry	Description
Anonymous All (Enable/Disable)	Feature + 889 Or *889	See Controlling Caller ID .

Table 4 VCX Feature Codes Alphabetical by Feature or Task (continued)

Feature	Feature Code Entry	Description
Anonymous Next (Enable/Disable)	Feature + 890, then <destination> Or *890*<destination>	See Controlling Caller ID .
Barge In	Feature + 428	Used with Silent Monitor. See Silent Monitor and Barge In .
Beep — Send	Feature + 331	Sends a page (a beep) between phones. The sending phone displays the target extension. The target extension displays the sending extension.
Call Forward Busy	Feature + 467, then <destination> Or *467*<destination>	See Call Forward Busy .
Call Forward Ring No Answer	Feature + 466, then <destination> Or *466*<destination>	See Call Forward No Answer .
Call Forward Universal	Feature + 465, then <destination> Or *465*<destination>	See Call Forward All .
Call History	Feature + 462	See Viewing the Call Logs .
Call Park a Call	Feature + 444, then <call park extension> (or accept the default)	See Call Park .
Call Pickup — Directed	Feature + 455, then <security code>, then <destination> Or *455*<security code>*<destination>	See Directed Call Pickup
Call Pickup — Group	Feature + 456, then <security code> Or *456*<security code>	See Group Call Pickup
Camp On	Feature + 469, then <destination>	Completes call when busy destination extension becomes available. See Camping on a Busy Extension .
Class of Service (COS) Override	Feature + 433, then <your extension>, then <your mailbox password>+ #, then <outside party number>	See Class of Service Override .
Conference Call	Feature + 430, then <destination>, then Feature + 430	See Setting up a Conference Call .

Table 4 VCX Feature Codes Alphabetical by Feature or Task (continued)

Feature	Feature Code Entry	Description
Conference Drop	Feature + 431, then <destination>, then Feature + 431	See Setting up a Conference Call .
Display Software Version	Feature + 837	Displays the current version of VCX software running on the phone.
Do Not Disturb (Enable/Disable)	Feature + 446 Or *446	See Activating Do Not Disturb .
Hands Free	Feature + 100	Enables or disable the Hands-Free feature. See Using the Hands Free Feature .
Headset	Feature + 112	See Using a Headset .
Hold	Feature + 402	See Putting a Call on Hold .
Hunt Group or Calling Group Login/Logout	Feature + 971, then <hunt group number> Or *971*<hunt group number>	See Hunt Groups .
Hunt Group Status	Feature + 972	See Hunt Groups .
Login/Logout (phone)	Feature + 128	
Mute	Feature + 101	See Muting Calls .
Mute Ringer	Feature + 489	See Mute Ringer .
OK	Feature + 120	Displays OK in the Display Panel. Used to make a call without waiting for the call completion time-out value to expire.
Password Stored Locally	Feature + 434, then <current password>	Stores the password you use to log in to your telephone on the phone (locally). If you use the VCX User Interface to change your password, use this feature code to set the password stored on the phone, thus synchronizing the passwords. See Changing Your Password and the VCX User Interface online help for more information.
Program	Feature + 410	Displays the Program menu in the Display Panel.
Redial	Feature + 401	See Redialing a Call .
Release	Feature + 111	Cancels the current operation.

Table 4 VCX Feature Codes Alphabetical by Feature or Task (continued)

Feature	Feature Code Entry	Description
Remote Call Forward	Feature + 468, then <extension to forward> + #, then <destination> + # Or *468*<extension to forward> *<destination>	See Remote Call Forward .
Retrieve Voice Mail	Feature + 600 Or *600	The first entry simulates pressing the MSG button. The second entry allows you to leave a message in another mailbox or access your own mailbox. Follow the prompts.
Scroll Down Button	Feature + 109	Simulates pressing the scroll Down button to navigate through items in the Display Panel.
Scroll Up Button	Feature + 108	Simulates pressing the scroll Up button to navigate through items in the Display Panel.
Serial Transfer	Feature + 471	Transferred call returns to attendant at the end of the call. See Serial Transfer .
Silent Monitor	Feature + 425	See Silent Monitor and Barge In .
Silent Monitor Block	Feature + 429	Allows an agent to make a private call by blocking an attempt to monitor the agent phone. See Silent Monitor and Barge In .
Soft Button 1	Feature + 105	Simulates pressing the Slct (Select) button to select an item in the Display Panel.
Soft Button 2	Feature + 106	Simulates pressing the Back button. Action depends on contents of the Display Panel. Either moves the cursor left one position or sorts listed items.
Soft Button 3	Feature + 107	Simulates pressing the Exit button to exit the current function in the Display Panel.
Speaker — On/Off	Feature + 104	Speak and listen without picking up the handset. Not available on Model 2101 or Model 3101 Telephones.
Speed Dial — Display	Feature + 464	Lists the configured speed dial numbers in the Display Panel.

Table 4 VCX Feature Codes Alphabetical by Feature or Task (continued)

Feature	Feature Code Entry	Description
Speed Dial — Personal	Feature + 601 + <i>n</i> Or *601*n , where <i>n</i> is the speed dial digit (1 through 9) associated with the number you want to dial.	Allows you to dial a personal speed dial number. To configure personal speed dialing, see Speed Dialing .
Speed Dial — System	Feature + 700 + speed dial number Or *700*n# , where <i>n</i> is the speed dial number associated with the number you want to dial.	Allows you to dial a system speed dial number. To configure personal speed dialing, see Speed Dialing .
Transfer	Feature + 420, then <destination> + hang up	This is an unattended transfer. For an attended transfer, see Transferring a Call .
Transfer to Voice Mail (Enable/Disable)	Feature + 440 Or *440	When enabled, transfers all calls to the voice mail. See Forwarding Calls to Voice Mail .
Transfer to Another User's Voice Mail	Feature + 441, then <destination> Or Transfer , then *441 * <destination>, then Transfer	See Transferring a Call to Another User's Voice Mail .
User Directory	Feature + 461	Lists the users in the local user directory or, if enabled, the users in the global user directory. See Viewing the User Directory .
View Personal Speed Dials	Feature + 463	Displays the personal speed dial numbers
View System Speed Dials	Feature + 464	Displays the system speed dial numbers

Table 4 VCX Feature Codes Alphabetical by Feature or Task (continued)

Feature	Feature Code Entry	Description
Volume — Up or Down	Feature + 102 to raise the volume or Feature + 103 to lower the volume	Adjusts the volume setting for the current mode: <ul style="list-style-type: none"> ■ If the handset is in the cradle and the speaker is disabled, adjusts the ring volume setting. ■ If the speaker is enabled, adjusts the speaker volume setting. ■ If the handset is not in the cradle and the speaker is disabled, adjusts the handset volume setting. See Controlling the Volume .

5

STANDARD FEATURES

This chapter describes the standard VCX telephone features that you can set up and access through the Telephone User Interface (TUI) on your telephone.

[Chapter 6](#) describes the telephone features that require configuration through the VCX User Interface.

This chapter contains the following topics:

- [Viewing the Call Logs](#)
- [Viewing the User Directory](#)
- [Controlling Caller ID](#)
- [Setting up a Conference Call](#)
- [Camping on a Busy Extension](#)
- [Transferring Your Phone Settings to Another Phone](#)
- [Forwarding Calls to Voice Mail](#)
- [Transferring a Call to Another User's Voice Mail](#)
- [Call Waiting](#)
- [Speed Dialing](#)
- [Call Forwarding](#)
- [Call Park](#)
- [Paging](#)
- [Call Pickup](#)
- [Silent Monitor and Barge In](#)
- [Remote Call Forward](#)
- [Hunt Groups](#)

Viewing the Call Logs

You can use the Call History feature to display your call logs. These are the logs of the 10 most recent calls to and from your telephone. From the call logs you can select calls and the phone automatically dials them.

To access and use the Call History:

- 1 Press the **Call Logs** soft button.
- 2 Use the Scroll buttons to highlight the call log you want to view.
- 3 Press the **Select** soft button.

Use the Scroll buttons to navigate through the list. The Display Panel always starts with the oldest call in the category you select. That is, the oldest call appears first and the most recent call appears last.

- 4 If you want to call a listed name, press the **Dial** soft button when the indicator is beside the name.
 - 5 To return to the main Display Panel, press the **Exit** soft button.
-

Viewing the User Directory

You can view a list of users in your organization and their extensions in the Display Panel. When you select a displayed user, your VCX phone automatically dials the extension.

The Users Directory can be local or global.

- Local users are typically located in the same office and share the same call processor.
- If your VCX system includes multiple sites (for example, regional and branch offices), each with one or more VCX call processors, you can display a global directory of all the users in your organization. Note that this option must be configured by your administrator. By default, you can view the local user directory.

The global directory is also available through the VCX User Interface (see [Chapter 6](#)).

To view the User Directory, use one of the following access options:

- Select the **Directory** soft button. By default, the display sorts the names alphabetically by last name. You can change the sort order to first name or extension by selecting the appropriate tab on the display.

Use the up and down scroll buttons to locate a user. When you have located the user, select the **Dial** soft button to automatically call the user.

You can also use the directory while you are on a call to find another user and transfer the call to that user.

- Select the **Features** soft button and enter **461**.

Controlling Caller ID

This section describes how to enable and use Caller ID privacy features.

By default, the VCX system shows your Caller ID (your name and extension) on the Display Panel of the telephone receiving your call if that telephone supports Caller ID. You can control whether the VCX system sends your Caller ID when you make a call. You can choose one of the following settings:

- Select one of the following settings for *all* your calls:
 - Send Caller ID information (Anonymous All is disabled).
 - Block Caller ID information (Anonymous All is enabled).
- Block Caller ID information for your *next* call. This setting only applies when the setting for all calls is set to *Send Caller ID information*. You must enter the destination number to call.

Anonymous All — When enabled, the system blocks your Caller ID to all dialed numbers and *Anonymous* displays on the destination phone.

Anonymous Next — When enabled, the system restricts Called ID information from displaying only on the next call that you make. This setting only applies when Anonymous All is disabled, or the setting for all calls is set to *Send Caller ID information*.

If you disable Caller ID, the system sends your Caller ID to all dialed numbers.

Using the Telephone User Interface

You can control Caller ID settings using the Telephone User Interface by enabling the appropriate feature.

To change the current setting using the Telephone User Interface, select **Features**. Use the Scroll buttons to navigate through the features.

If Caller ID (Anonymous All) is disabled and you want to block your Caller ID for the next call only:

- 1 Pick up the handset.
- 2 Select the **Features** soft button.
- 3 Use the Scroll buttons to navigate to **Anonymous Next**.
- 4 Press the **Select** soft button.
- 5 Dial the number. Your ID is not sent to the caller.

Using the VCX User Interface

You can control Caller ID settings using the VCX User Interface by enabling the appropriate feature.

To change the current setting using the VCX User Interface:

- 1 Log into the VCX User Interface and select **My Extensions** and then select the **Button Mappings** tab.
- 2 Select the 3103 Manager phone.
- 3 In any one of the top three **Feature Type** pulldown windows, set the type to *Anonymous All* if you want to block your Caller ID for all calls, or select *Anonymous Next* to block your Caller ID for the next dialed number. These feature types are mapped to your phone's Access buttons.
- 4 Click **Save** and log out.
- 5 To block Caller ID information for all calls, press the Access button associated with *Anonymous All*. The LED will go on, indicating that the feature is enabled.
- 6 To block Caller ID information for only the next dialed call, press the Access button associated with *Anonymous Next*. The LED will go on, indicating that the feature is enabled. When the call is completed, the LED will go off.

Setting up a Conference Call

The conference feature enables you to have three people on one call (4-way calling).



If your telephone is part of a bridged extension, see [Call Transfer, Call Conferencing, and Bridged Line Calls](#) for additional information.

The following sections describe how to set up an unannounced conference call and an announced conference call. In either type of conference call, if one of the participants hangs up, the other two participants remain connected.

Unannounced Conference In an unannounced conference, you conference in the person without notifying that person:

- 1 While on a call, press **Conference** or **Feature + 430**. The system places your caller on hold.
- 2 Dial the number of the person you want to conference in.
- 3 Press **Conference** or **Feature + 430** again. The three-way conference begins when the recipient answers the call.

Announced Conference In an announced conference, you announce to the recipient that you are conferencing them into a call. The recipient can then decide whether to take the call:

- 1 While on a call, press **Conference** or **Feature + 430**. The system places your caller on hold.
- 2 Dial the extension of the person you want to conference in, then press the **OK Access** button (or press **Feature + 120**).
- 3 When the called party answers, announce the conference.
 - If the recipient wants to take the call, press **Conference** or **Feature + 430**. Now three people are on the same call.
 - If the recipient does not want to take the call, hang up the second call and go back to the first call by pressing the **Hold** button for that call.

Dropping a conference recipient Once a conference has been established, the conference originator can drop a conference recipient from the conference. To do this:

- 1 While on a conference, the conference originator press **Conference** and then press **Feature + 431**. A list of conference recipients displays in the Display Panel.
- 2 Scroll to the extension of the recipient you want to drop from the conference and press the **Drop** soft button.

Camping on a Busy Extension

The Camp On feature allows you a call to a busy or an unanswered internal telephone, and then be automatically called back when the

destination phone becomes available. When you activate camp on, the system monitors the called telephone. When the extension can receive a call, the system automatically dials your phone (using a priority ring or other audible ring tone that is different than your programmed ring tone) and redials the original called extension.



You can camp on system extensions. You cannot camp on external phone numbers, hunt groups, pickup groups, or paging groups. If the called extension does not become free within a time period specified by your administrator, Camp On expires.

To camp on an extension you call:

- 1 When you make a call and hear a busy tone, press **Feature + 469**. The system camps on the phone you are calling. You can hang up.
- 2 When the called extension becomes available, the system calls your phone. When you answer your phone, the called extension begins to ring.

To camp on an extension when you transfer a call:

- 1 When you are transferring a call and hear a busy tone, press **Feature + 469**. The system camps on the phone you are calling. Explain to the person whose call you are transferring that the call will call back. When you hang up, the person whose call you are transferring is put on hold.
- 2 When the called extension becomes available, the system calls the destination extension.

If Camp On expires before the destination becomes available, the system calls you back and connects you to the person whose call you were transferring.

Transferring Your Phone Settings to Another Phone



This feature enables you to use any 3Com phone attached to the same VCX system (call processor) as your phone with all your phone's settings.

It is possible for an administrator to lock an extension to a particular phone. If this is the case, you cannot program the phone to use your extension.

To transfer your phone's settings to another phone:

- 1 Log out of your own phone by pressing the **bottom right** soft button (Advanced Settings) + **6**.



If your administrator has enabled the Multiple Contacts feature for your extension, you do not have to log out of one phone before logging into another.

- 2 From the phone that you want to use as yours, enter your phone number and password:
 - a Press the **bottom right** soft button (Advanced Settings) + **4**, enter your phone number, and then press **#**.
 - b Press the **bottom right** soft button (Advanced Settings) + **5**, enter your password, and then press **#**.
- 3 When you are finished using the other phone, log out of the phone by pressing the **bottom right** soft button (Advanced Settings) + **6**.
- 4 Log back into your own phone by pressing the **bottom right** soft button (Advanced Settings) + **6**.

Forwarding Calls to Voice Mail

You can forward all incoming calls to your voice mailbox.

When you forward incoming calls to your voice mailbox:

- An incoming call rings once on your phone and is then sent to your voice mailbox. If you are logged in to multiple phones, each using the same phone number, and one of the phones enables forward to voice mail, the feature applies to all phones—an incoming call rings once on all of the phones and is then sent to your voice mailbox.
- If you enable forward to voice mail while one or more calls are ringing, the pending calls are sent to your voice mailbox and forward to voice mail is enabled for all subsequent calls.
- If you are a Hunt Group member, personal (non-Hunt Group) calls go to your voice mailbox. However, Hunt Group calls always ring on a member's phone, regardless of your personal phone setting.

To forward incoming calls to your voice mailbox for a Manager's phone:

- 1 Press the **Features** soft button.
- 2 Scroll to the **Forward to Mail** feature.
- 3 Press the **Select** soft button.

To disable this feature, repeat steps 1 through 3.

Transferring a Call to Another User's Voice Mail

You can transfer a connected call directly to another subscriber's voice mail rather than that subscriber's phone extension. The subscriber can be located locally or at a remote site.

To transfer a call to another subscriber's voice mail:

- 1 Press the **Features** soft button + **441**.

The Display Panel shows the following prompt:

```
Transfer VMail Number:
```

- 2 Enter the extension of the subscriber whose mailbox will receive the call.

The caller hears the mailbox greeting of the target subscriber but the subscriber's phone does not ring.

Call Waiting

The Call Waiting feature provides a "beep" on your current call to let you know that another call has arrived on another access line.

- 1 When you hear the "beep", press the **Hold** button to put the current call on hold.
- 2 Press the **Access** button for the incoming call.
- 3 To toggle between the two calls, put the current call on hold and then press the **Access** button for the call you want.

Speed Dialing

This section describes the following types of speed dialing:

- **One-Touch Speed Dials** — With this type of speed dialing, a telephone number (internal or external) is mapped to a dedicated Access button on your phone. Pressing the button dials the call.
- **Personal Speed Dials** — With this type of speed dialing, you map a number (internal or external) to a feature code value. To use a personal speed dial, you press the **Feature** button and enter the appropriate feature code.

Feature code 601 plus 1 through 9 inclusive, are available, which allows you to create up to 9 personal speed dials. Personal speed dials allow speed dialing on phones that do not have Access buttons.

Personal speed dials are available on all VCX telephone models.

- **System Speed Dials** — With this type of speed dialing, your administrator maps commonly used numbers (internal or external) to feature code values. To use a system speed dial, you press the **Feature** button and enter the appropriate feature code and the speed dial number.

The administrator creates system speed dial numbers. System speed dials can be dialed on all VCX telephone models.

Note that, a configured one-touch speed dial is also mapped to a feature code (the speed dial number mapped to the first speed dial Access button is also mapped to feature code 601, the speed dial number mapped to the second speed dial Access button is also mapped to feature code 601, and so on). This means that on a phone with four configured speed dial numbers, you can dial a speed dial number by either pressing an Access button or entering feature code 601 + an index number 1 through 9.

This section describes how to set up speed dialing through the Telephone User Interface. You can also enable speed dialing through the VCX User Interface. See [Chapter 6](#) for information on accessing the VCX User Interface; see the online Help for information on creating speed dials.

Note that the two interfaces are synchronized. A speed dial created or modified in one interface appears in the other interface. A speed dial deleted in one interface is deleted in the other interface.



Your administrator can configure speed dial numbers for your phone. You can reassign these administrator configured speed dials unless the administrator has optionally enabled BLF (busy light flashing) for a speed dial. During speed dial configuration, the administrator can enable BLF for the status light associated with the speed dial button. When the user assigned to that speed dial button is on a call, the status light is lit. If the administrator has enabled the BLF for a speed dial, you cannot reassign a different number for that speed dial.

Configuring Personal Speed Dial Numbers

You set up speed dialing through the Telephone User Interface using the **Feature** soft button. Refer to the chapter that describes the buttons and controls on your phone for the location of the available speed dial Access buttons.

To configure a speed dial number using the **Feature** soft button and the **Speed Dial** menu:

- 1 Press **Feature + 410**.

The Main menu appears.

- 2 Press **[3]** to access the Speed Dial menu.

The Display Panel lists the first speed dial:

Speed dial 1:

If the speed dial is already configured, the Display Panels show the configured number, for example:

Speed dial 1:

1001

To locate the speed dial number you want to configure, press the speed dial number (1 through 9) or use the up and down scroll buttons



If you assign a number to a speed dial that does not have a corresponding Access button, you can speed dial the number only by entering the appropriate feature code. Or you can scroll through the display panel directory.

- 3 Press the Change soft button, then enter the number you want to associate with this speed dial. Include all prefix numbers that you would normally dial, such as a **9** or **8** or **1** to access an outside line, and, if necessary, the country code or area code.
- 4 To store the number, press the **Enter** soft button (or press #).

Alternatively, you can directly configure a speed dial number with a speed dial Access button:

- 1 Press **Feature + 410 + 3**.
- 2 Press the speed dial Access button you want to configure.
- 3 Enter the number you want to associate with this button. If a number is already configured for this button, you can enter a different number.
- 4 To store the number, press the **Enter** soft button (or press #).



*Make sure you write the name of the person whose number you have stored and the corresponding **Speed Dial Access** button or feature code.*

Editing Personal Speed Dial Numbers

You can change or delete any personal speed dial number that you previously configured using the Telephone User Interface.

To change or delete a previously configured speed dial number:

- 1 Select the **Features** soft button + **410 + 3**. The **Personal Speed Dial Index** displays.
- 2 Scroll down to the personal speed number you want to change.
- 3 Press the **Change** soft button and then press the **Delete** soft button to delete part or all of the number.
- 4 Enter the new number and press the **Enter** soft button to complete the change. Press **Exit** to return to the main display.

Dialing Personal Speed Dial Numbers

The method you use to dial a configured speed dial number depends on your phone and whether or not the number is mapped to a speed dial Access button.

To dial a number configured as a speed dial on a VCX phone with one or more speed dial Access buttons, press the appropriate button. If the number is not associated with a button, use the next procedure.

To dial a configured speed dial number on any VCX phone:

- 1 Pick up the handset. Or press the **Speaker** button.
- 2 Press **Feature**.
- 3 Enter the feature code associated with the number you want to dial.

For example, if the number you want to speed dial is mapped to `Speed dial 2`, enter the following through the Telephone User Interface:

Feature + 601 + 2

Alternatively, you can skip pressing the **Feature** button and enter:

***601*2**

Note that, with this syntax, you *cannot* enter ***602**.

You can also use the following method to dial a speed dial number on any VCX phone:

- 1 Press **Feature + 410 + 3**.

The Display Panel lists the first speed dial, for example:

Speed dial 1:

1001

Use the up and down scroll buttons to locate the speed dial number you want to dial.

- 2 Press the **Dial** soft button under the Display Panel.

Your phone dials the number.

To exit the speed dial list in the Display Panel, press the **Exit** soft button.

In addition to using the Feature menu to list speed dial numbers, you can view the speed dial numbers configured on your phone by pressing **Feature + 463**.

Dialing System Speed Dial Numbers

The administrator can set up system-wide speed dials for numbers that are dialed frequently by many internal users. You can view the system-wide speed dial list through the VCX User Interface (see [Chapter 6](#) for information) or you can view and dial numbers from it using the telephone display panel.

To use a system speed dial number:

- 1 Pick up the handset or press the **Speaker** button.
- 2 Press the **Feature** button plus **700** plus the system-wide speed dial number for the number that you want to call. Alternatively, you can press the **Feature** soft button, scroll to **Speed Dials: System**, press **Select**, scroll to the number that you want to dial, and press **Select** again.



*If you dial a speed dial code that has no number assigned to it, the display panel on your telephone shows the message "**No number stored.**"*

Call Forwarding

This section describes how to enable and use call forwarding features set up through the Telephone User Interface (TUI). You can also configure and enable call forwarding through the VCX User Interface. See [Enabling Call Forwarding](#).

You can use the TUI on your phone to specify:

- Where you want your call to be forwarded
- The condition that results in the system forwarding a call:
 - **No Answer** — Redirects incoming calls to another destination when your phone rings for a configured time period (the default is 20 seconds). You can forward all unanswered calls by enabling **Call**

Forward No Answer (feature code 466) and entering the number to which you want the calls forwarded.

- **Busy Line** —Redirects incoming calls to another destination when your phone is busy. If you have multiple lines, busy means that all lines are in use. You can forward all calls that come in when your lines are busy by enabling **Call Forward Busy** (feature code 467) and entering the number to which you want the calls forwarded.
- **All Calls** — Redirects incoming calls to another destination unconditionally. Use this feature, also called Forward Universal, when you plan to be away from your phone for an extended period of time. You can forward all unanswered calls by enabling **Call Forward All** (feature code 465) and entering the number to which you want the calls forwarded.



If your telephone is part of a bridged extension, see [Call Forward, Forward to Voice Mail, and Bridged Line Calls](#) for additional information.

You can also use the VCX User Interface to configure Call Forward, Fall Back to Coverage. When you enable this feature, a forwarded call that is not answered at the forwarding destination falls back to your extension's coverage (either voicemail or Auto Attendant). See [Enabling Call Forwarding](#).

Call Forward No Answer To forward your calls to another extension when your extension is not answered:

- 1 Press the **Features** soft button.
- 2 Scroll to **Call Forward No Answer**.
- 3 Press the **Select** button.
- 4 Enter the extension of the subscriber whose extension will receive the call and select **Enter** (or press #).

To disable **Call Forward No Answer**, repeat steps 1 through 3.

Call Forward Busy To forward your calls to another extension when all your lines are busy:

- 1 Press the **Features** soft button.
- 2 Scroll to **Call Forward Busy**.
- 3 Press the **Select** button.

- 4 Enter the extension of the subscriber whose extension will receive the call and select **Enter** (or press #).

To disable **Call Forward Busy**, repeat steps 1 through 3.

Call Forward All To forward all your calls to another extension:

- 1 Press the **Features** soft button.
- 2 Scroll to **Call Forward All**.
- 3 Press the **Select** button.
- 4 Enter the extension of the subscriber whose extension will receive the call and select **Enter** (or press #).

To disable **Call Forward All**, repeat steps 1 through 3.

Call Park

Use the Call Park feature to place a call in a holding pattern and make it available for you or for another user to pick up from any telephone on the system by dialing the Call Park extension.

The Call Park feature is useful when the recipient is elsewhere in the building or you want to continue a call on another telephone and transferring the call does not give you enough time to retrieve it.

When you park a call, you assign it a Call Park extension, which you (or another user) use to retrieve it. The default Call Park extension numbers are 800 through 899 inclusive. Ask your administrator to verify the Call Park extensions for your location. If the specified Call Park extension is in use or if no extension is specified, VCX selects the next available Call Park extension.

A call remains parked for 5 minutes. This default value can be adjusted by your administrator. If the call is not answered 5 minutes after it is parked, the user who parked the call is called back. If the user is not available, the parked call is forwarded to the user's call coverage point.



If your telephone is part of a bridged extension, see [Call Park and Bridged Line Calls](#) for additional information.

To park a call:

- 1 While you are on a call, press the **Right** soft button for the call for the Actions menu.
- 2 Scroll to **Call Park**.
- 3 Press **Select**.
- 4 Dial the park extension and press #.
- 5 Notify another user about the parked call,
 - a Select an Access button for outgoing calls and dial the user's extension.
 - b When the call is answered, tell the user the Call Park extension number, for example 818.
 - c Hang up.
The user dials the Call Park number and the system connects the call automatically.
- 6 To retrieve a parked call yourself:
 - a Pick up the handset of any telephone on the system.
 - b Dial the Call Park extension that was assigned to the call.
The system connects you to the parked call.

Paging

Paging lets you activate the speakers and broadcast a message to all of the available phones in a paging group. Your administrator defines the members of a paging group and an extension to dial to page that group. A phone in a group is available to receive pages if it has a speaker, unless:

- the phone is not logged in
- the phone has a call ringing, connected, or on hold
- the phone has Do Not Disturb, Call Forwarding, or Forward to Voicemail enabled.

Note that you do not need to be a member of a page group to send a page to that group; you just need to know the extension for that group.

A page is subject to the following restrictions:

- You cannot park, transfer, hold, conference, or pick up a page.
- You cannot camp on a page group extension.

- A page cannot be bridged (see [Enabling Bridged Extensions](#) for information about bridging).

If you are sending or receiving a page, you can drop the page by using the speaker button to disconnect the page, by picking up and replacing the receiver, or by pressing the **Release** button.

Paging a Group You can view the page groups, the group extensions, and the members of those groups by accessing the VCX User Interface (see [Accessing the VCX User Interface](#)).

To page a group:

- 1 Pick up the handset.
- 2 Dial the appropriate page group extension.

When you dial the page group extension, speakers are activated on the telephones that are members of the group.

- 3 Speak the message you want to broadcast into the handset.
- 4 Hang up when you are finished.

Call Pickup

Use the Call Pickup feature to answer a call that is ringing on another telephone.

There are two types of call pickup:

- **Directed Call Pickup** — Allows you to answer a call ringing on the phone of a specific user. Both you and the other user must be members of the same Directed Call Pickup group. Each Directed Call Pickup group is assigned a security code by the administrator. You must enter this security code when using Directed Call Pickup to answer a call.
- **Group Call Pickup** — Allows you to answer a call ringing on the phone of any user who is a member of a configured Group Call Pickup group. A Group Call Pickup group is a collection of phones that allow each member of the group to answer another member's calls. Your administrator can also configure a Group Call Pickup group that allows non-group members to answer a call ringing on a phone in the group.



If your telephone is part of a bridged extension, see [Call Pickup and Bridged Line Calls](#) for additional information.

Directed Call Pickup To answer a call that is ringing on a specific user's telephone:

- 1 Pick up the handset.
- 2 Press the **Features** soft button.
- 3 Scroll to **Pickup, Directed**.
- 4 Press **Select**.
- 5 Dial the extension of the ringing telephone and press **#**.
The call is directed to your telephone.

Using One-Touch Pickup:

- 1 Pick up the handset.
- 2 Press the Access button that you have assigned to **Directed Pickup**.
- 3 Dial the extension number of the ringing telephone.

Group Call Pickup To answer a call that is ringing on a group member's telephone:

- 1 Pick up the handset.
- 2 Press the **Features** soft button.
- 3 Scroll to **Pickup, Group**.
- 4 Press **Select**.
- 5 Dial the group number of the ringing telephone and press **#**.

The call is directed to your telephone and call stops ringing on the other member phones. If multiple calls are ringing, the first call received is directed to your telephone.

**Call Pickup
Interaction With
Other Features**

This section describes how call pickup interacts with other VCX phone features. Note the following considerations:

- **Call Forwarding** — If both the phone forwarding a call and the phone receiving the forwarded call belong to the same call pickup group, then any member of the group may answer the call.
- **Camp On** — A call pickup group member or a directed call pickup user cannot answer a camp on callback call.

- **Conference Calls** — A conference call cannot be picked up at another extension. A conference originator can, however, pick up a call and add it to the conference call.
- **Display Panel** — When you pick up a call, the telephone Display Panel shows a confirmation message, for example, `PickUp Marie x3434`.
- **Hunt Groups** — A call pickup group member can also be a member of a hunt group. Call pickup group members can use either directed call pickup or group call pick up to answer a call that is ringing at another group member's telephone.
- **Speed Dials** — You or your administrator can assign the following to a speed dial button:
 - The feature code for directed call pickup (455) or the feature code for group call pick up (456), and a telephone number.
 - Only the feature code for directed call pickup (455) or the feature code for group call pick up (456).

Silent Monitor and Barge In

The VCX system supports Silent Monitor and Barge In. These two features are typically used in call centers to allow supervisors to listen to (monitor) and optionally join (barge in) a conversation between an agent and a customer to ensure proper customer support. Unless the supervisor barges in, neither the agent or the customer are aware that the supervisor is monitoring the call.

To invoke Silent Monitor, the supervisor enters a feature code followed by the extension to be monitored (see [Monitoring a Call](#)). The supervisor, in this case, is defined as a user who is allowed to invoke the Silent Monitor feature for that particular extension. Permission to monitor one or more extensions is configured through the VCX Administrator Interface (see the *VCX Administration Guide*). The supervisor must use a phone with a Display Panel (not a 3Com Model 3100 Entry Telephone). If a supervisor attempts to monitor an extension without permission, the supervisor hears an error tone and the LCD shows `Unauthorized`. The supervisor and the monitored agent can be located at different sites.

If a supervisor attempts to monitor an agent's extension, the supervisor phone LCD will display the error message `no calls to supervise if:`

- The agent is not logged in.

- The agent is not on a call.
- The agent is currently monitored by another supervisor.

While in Silent Monitor mode, the supervisor can join the conversation by entering the feature code for Barge In. After barging in, the supervisor can return to Silent Monitor mode by reentering the Silent Monitor feature code. See [Barging In](#).

A user can ensure a private call by blocking Silent Monitor and Barge In. To make a private call, the user enters a feature code before dialing the call.

Note the following Silent Monitor and Barge In feature conditions and restrictions:

- Multiple supervisors cannot monitor the same extension at the same time.
- If an agent parks a monitored call, initiates a conference, or transfers the call, the supervisor will be disconnected from the session.
- If a supervisor attempts to park, conference, or transfer a monitored call, the action will be ignored and the Display Panel shows `Not supported operation`.
- If a customer or agent terminates a monitored call by hanging up, the supervisor will be disconnected from the session.
- Supervisors cannot monitor conference calls.
- The agent, the customer, and the supervisor can place a monitored call on hold. The results depend on who places the call on hold and whether or not Music On Hold (MOH) is enabled.
- If the VCX call processor fails during an established silent monitoring or barge in session, the audio is not affected. However, none of the parties in the call can invoke mid-call features.
- The supervisor can monitor a Hunt Group call by selecting the member's extension, not the Hunt Group's extension.
- Bridge line connected calls can be monitored by selecting the extension of the connected party (primary or secondary, depending on who is connected).

Monitoring a Call

Silent Monitor allows a supervisor to listen to calls that come in to an agent's extension. The supervisor must be granted explicit permission by

the VCX administrator to monitor one or more extensions. If you have been granted monitoring privileges, your administrator will give you a list of the extensions you can monitor.

To monitor a call on an agent's extension from a Manager's Telephone:

- 1 Pick up the handset.
- 2 Press the **Feature** soft button.
- 3 Scroll to Supervisory Monitoring.
- 4 Press **Select**.
- 5 Enter the extension of the agent you want to monitor and press **Select**.

To terminate participation in a monitored call, hang up. This has no effect on agent-customer communication (the agent-customer session remains active).

If you want to join a monitored call, see the following section, [Barging In](#).

Barging In Barge In allows a supervisor to speak to the agent and customer during a monitored call. While you are silently monitoring a call, to barge in when you are monitoring a call, press **Feature + 428**. To return to silent monitor mode, press **Feature + 425**.

To terminate participation in a barged in call, hang up. This has no effect on agent-customer communication (the agent-customer session remains active).

Blocking Call Monitoring An agent can prevent a supervisor from monitoring an outgoing call. This allows the agent to make private call. Monitor blocking can be enabled for one call at a time. That is, an agent cannot enable the monitor blocking feature for all subsequent calls. Furthermore, this feature works for outgoing calls only; the agent cannot block monitoring for an incoming call.

Note the following blocking considerations for call monitoring

- Blocking can be invoked before dialing a call or during a call.
- The monitor blocking feature can be mapped to a button.
- After invoking monitor blocking for a call, monitoring is blocked for the duration of that call. If the call is disconnected (during transfer or a

call park, for example), blocking is disabled and the call can be monitored. If the call is reconnected (for a park timeout, for example), blocking is disabled and the call can be monitored.

- Blocking is effective only for calls that can be monitored. For example, invoking monitor blocking for a conference call has no effect on the call because conference calls cannot be monitored.

To block call monitoring on an agent extension to make a private call:

- 1 Pick up the handset.
- 2 Press **Feature + 429**.

The Display Panel shows the following prompt:

```
Enter the phone number:
Press # to complete!
```

- 3 Enter the extension of the private call and press #.

Alternatively you can combine steps 2 and 3 by using the following single command after picking up the handset:

```
*429*<extension>
```

For **<extension>**, you can either enter the private phone extension or press a speed dial button mapped to that extension.

Remote Call Forward

The Remote Call Forward feature allows you to configure the forwarding options of a phone from another phone in the network. This is useful if, for example, a person A is on vacation and all of person A's calls must be forwarded to person B. This feature enables person B to configure Call Forward Universal on the source phone (person A). Note that person A can be at one site and person B can be at a different site.

The VCX administrator must authorize use of the Remote Call Forward feature. For example, if the administrator authorizes you to change person A's forwarding options, you can enter a feature code (468) and redirect person A's calls to any other extension, including your own.

When successfully configured, the remote (destination) phone's LED (if available) will flash for all forwarded calls, and the LCD will also display a call forward message.

To remotely enable a phone to forward calls to another extension:

- 1 Pick up the handset.
- 2 Press **Feature + 468**.

The Display Panel prompts you to enter the remote phone number.

- 3 Enter the extension of the phone whose calls you want to forward and press #.

The Display Panel prompts you to enter the extension of the phone that will receive the forwarded calls.

- 4 Enter the extension of the phone that will receive forwarded calls and press #.

Alternatively, you can combine steps 2, 3, and 4 by entering the following command:

```
*468*<source extension>*<destination extension>
```

Remote call forwarding can be disabled either on the phone that set up remote call forwarding or on the extension whose calls you no longer want to remotely forward.

For example, extension 1001 has used feature code 468 to specify that all of extension 1000's calls be forwarded to extension 1002. You can disable remote call forwarding on extension 1000 or 1001:

- On extension 1001:

- a Press **Feature + 468**.

- b Enter the extension whose calls you no longer want to remotely forward (in this case, 1000) and press #.

The Display Panel shows the extension of the phone receiving the forwarded calls (in this case, 1002).

- c Delete the extension number by pressing Soft button 3, followed by Soft button 2, then press #.

- On extension 1000, press **Feature + 465**.

Hunt Groups

Your administrator can establish formal and informal call centers so that incoming calls can be directed to several telephones that have been associated into hunt groups.

A call center is a general term that refers to any system that accepts incoming calls to a site, ensures that those calls are sent to the proper destination within the site, and manages database records on call activity and distribution. The call center can be used, for example, as a help desk, a reservations counter, an information hotline, or a customer service center.

Incoming calls that arrive at your company can go either to:

- Your extension and the call coverage point you have set up (see [Configuring a Call Coverage Point](#)).
- A hunt group that follows the call coverage path assigned by an administrator for that group.

A hunt group is a group of VCX phone extensions that are configured under a virtual extension. An incoming call to the virtual extension rings on the phone of one hunt group member. If that member's telephone is in use, or if that member does not answer the call, the system "hunts" for another member of the group until the call is answered or is forwarded to the group call coverage point. For example, if there are no available members of the hunt group, the call might be forwarded to a group mailbox or to the receptionist.

An administrator can configure a hunt group in which all members are fax machines. Incoming faxes are routed to an available fax machine. Depending on the type of hunt group configured, if no fax machine is available, pending faxes may be queued until a machine becomes available or they may be sent to the call coverage point.

The method used to hunt for an available hunt group member is determined by an administrator-configured call coverage pattern for that group. Pattern types include linear, circular, and calling groups. These patterns are described in [Hunt Group Types](#).

If you are a member of a hunt group, your administrator should provide the following information:

- The type of hunt group to which you belong. The hunt group type determines the ringing pattern followed by incoming calls. See [Hunt Group Types](#).
- Your hunt group number. You need this number to log in to the hunt group. You must be logged in to receive calls directed to the hunt group. See [Logging In to a Hunt Group](#).

You can be a member of, and logged in to, multiple hunt groups, which may be of different hunt group types.

As a hunt group member, you should also be aware of how hunt group calls work with other VCX phone features, such as call conferencing. See [Hunt Group Interaction With Other Features](#).

Hunt Group Types

The type of hunt group to which you belong determines how incoming calls are allocated to group members. Your administrator can configure a linear hunt group, a circular hunt group, and a calling group.

To illustrate the differences between hunt group types, assume the administrator has configured four members for each type: A, B, C, and D. Note that a member must be logged in to both the VCX system and the hunt group to receive a call.

- **Linear Hunt Group** — An incoming call always rings at the first member phone of the group, then, if the call is not answered, at the phone of the next member in the group list.

For example, if A, B, C, and D are all available, an incoming call will always ring first at member A's extension. If A does not answer, the call is routed to member B's extension, and so on until the last member of the group is reached. If no member is available, the call is routed to the call coverage point immediately. When the total timeout value configured for the group is reached or the last hunt group member fails to answer (whichever happens first), the call is routed to the call coverage point (see the discussion of timeout values and call coverage points later in this section).

- **Circular Hunt Group** — An incoming call rings at the member phone following the member to whom the last call was routed. If the call is not answered, the call rings at the phone of the next member in the group list.

For example, if A, B, C, and D are all available and member B received that last call, the next call will ring at member C's extension. If C does not answer, the call is routed to member D's extension, and so on until the total timeout value for the group is reached (see the discussion of timeout values later in this section).

- **Calling Group** — An incoming call simultaneously rings on all member phones that are logged in, even if a member is on another call.

For example, if A, B, C, and D are all available, an incoming call will ring simultaneously at all four extensions until the total timeout value for the group is reached (see the discussion of timeout values later in this section).

For each hunt group type, your administrator configures two timeout values:

- **Device Timeout** — Specifies how long the VCX call processor rings at one extension before moving to the next extension if there is no answer.
- **Total Timeout** — Specifies how long the VCX call processor attempts to make a connection within the hunt group before directing the call to the hunt group’s default call coverage point. The administrator can configure the call coverage point to be:
 - A voice mailbox
 - Another hunt group
 - An individual extension
 - An Auto Attendant number
 - An external phone number

Ask your administrator for information on timeout values and your hunt group’s default call coverage point.

[Table 5](#) summarizes how the three hunt group types route incoming calls.

Table 5 Hunt Group Behavior

Condition	Linear Hunt Group Result	Circular Hunt Group Result	Calling Group Result
No members	Go to call coverage.	Go to call coverage.	Go to call coverage.
All members logged out	Go to call coverage.	Wait for a member to log in or until total timeout reached.	Go to call coverage.
All members busy	Go to call coverage.	Wait for a member to become available or until total timeout reached.	Queue the call and wait for an available member or until total timeout reached.

Table 5 Hunt Group Behavior (continued)

Condition	Linear Hunt Group Result	Circular Hunt Group Result	Calling Group Result
All members available	Route call to first member in the list.	Route call to the member following the member to whom the last call was routed.	Ring all member phones.
Total timeout reached	Go to call coverage.	Go to call coverage.	Go to call coverage.



Hunt Group calls routed to a call coverage point always go to the point configured for the Hunt Group, not to the point configured for (or by) the Hunt Group member (that is, the member's personal call coverage point). If the member has Do Not Disturb enabled, personal (non-Hunt Group) calls go to the call coverage point. However, Hunt Group calls always ring on a member's phone, regardless of the Do Not Disturb setting.



If your telephone is part of a bridged extension, see [Hunt Groups and Bridged Line Calls](#) for additional information.

Logging In to a Hunt Group

When your administrator gives you your hunt group membership information, you can log in to your hunt group (or groups if you have been assigned membership in multiple groups). You must be logged in to a hunt group to receive calls for that group.



You must be logged in to your VCX system account before you can log in to a hunt group. If you are not logged in to the VCX system, which requires password authentication, you cannot log in to a hunt group. See the overview section for your phone in this guide.

To log in to a hunt group:

- 1** Select **Features**.
- 2** Scroll to **Hunt Group Login Enabled**.
- 3** Press **Select**.
- 4** Enter the group number.
- 5** Enter the group password and press **#**.

To log out of a hunt group, repeat the steps used to log in.

Hunt Group Interaction With Other Features

This section describes how participation in a hunt group interacts with other VCX phone features. Note the following considerations:

- A hunt group call can be added to a conference. The member receiving the call can conference with another extension or with another hunt group. Both announced and unannounced conferences are supported (see [Setting up a Conference Call](#)).
- A hunt group call can be put on hold and taken off hold without losing the caller.
 - If a hunt group member puts a call on hold, that member can receive other calls.
 - A hunt group caller on hold will hear hunt group Music On Hold.
- A hunt group call can be parked and then picked up by any user on the same site.
- If the VCX phone has Hands Free enabled, an incoming call to a hunt group will not be picked up automatically.
- A hunt group member's personal phone settings (for example, Call Forward, Call Coverage point, and Do Not Disturb) are not invoked on Hunt Group calls
- An external call to a private user (someone not in the hunt group) can be transferred to a hunt group.
- Both attended and unattended call transfers are allowed for calls to a hunt group or from a hunt group.
- After reaching an Auto Attendant, a caller can enter a hunt group extension and be transferred to a Hunt Group.
- Internal and external callers that are forwarded to voice mail can leave a message and navigate through the voice mail options.
- If a hunt group call is routed to a voice mailbox or Auto Attendant call coverage point but the routing fails (for example, because no ports are available), the call is requeued for the hunt group.
- Each time a call is put back in a hunt group queue, it is treated like a new call.
- If you are a member of one or more hunt groups, the phone message button acts as a MWI for the hunt group voice mailbox even if you are not logged in to the hunt group. Pressing the message button displays a menu which shows number of new messages in each mailbox, including your personal mailbox. You can use the arrow navigation

keys to locate a voice mailbox. Press the message button to access the selected mailbox.

Viewing Hunt Group Membership and Status

You can use the Telephone User Interface to view the hunt groups you belong to and your current login status for each group.

To view hunt group information enter the following feature code:

Feature + 972

The Display Panel on the phone displays the hunt groups you belong to and your current status.

Use the up and down scroll buttons to navigate through the hunt group list. The first line displays the name and number of the hunt group. The second line displays your current status.

- Press **Change** soft button below the Display Panel to change your current login status.
- Press **Exit** soft button below the Display Panel to exit from the hunt group display.

When you change your login status, the Display Panel shows `HuntGroup Login Enabled`. If you are logged into multiple phones using the same phone number, this message appears on all phone displays. While this message appears in the Display Panel, press **Feature + 972** to display the hunt group list.

You can also use the VCX User Interface to view the hunt groups you belong to and your current login status for each group.

6

USING THE VCX USER INTERFACE

This chapter describes how to access the VCX User Interface application. It also provides a description of the options available to manage your user account and VCX telephone from this web-based application. Features that require configuration through the application and, subsequently, on the telephone itself are described in more detail.



Your administrator determines whether the features in this chapter are available for your telephone or for the entire system. Some of these features may not be available to you.

This chapter includes the following topics:

- [Accessing the VCX User Interface](#)
- [VCX User Interface Overview](#)
- [Enabling Call Forwarding](#)
- [Configuring a Call Coverage Point](#)
- [Enabling Bridged Extensions](#)
- [Logging Out](#)

Accessing the VCX User Interface

You can use the VCX User Interface to access and manage advanced VCX telephone features, change your web login password, and modify your personal account information.

The VCX User Interface is a web-based application. Before you begin, obtain the following information from your system administrator:

- Web login username
- Web login password
- Web address (URL) for the VCX User Interface



Your browser must have cookies and Java script support enabled to start a VCX User Interface provisioning session.

To log in to the VCX User Interface:

- 1 In your web browser's address bar, enter the VCX User Interface web address and press **Enter**.
- 2 On the **3Com VCX V7000 Networked Telephony Solution** window, click **User Interface**. The Login dialog box appears.
- 3 In the **Username** field, type your web login name.
- 4 In the **Password** field, type your web login password.
To clear the username and password fields, click **Reset**.
- 5 Click **Submit**.

The VCX User Interface displays the Welcome window.

VCX User Interface Overview

The Welcome window illustrates the general structure of the VCX V User Interface.

The left column displays four options:

- **Welcome**
- **My Extensions**
- **Calling Features**
- **Log Out**

Each option (except **Log Out**) is associated with a set of tabbed pages shown on the right side of the window. When you select an option, the set of tabbed pages changes. Click on a tab to display its contents.

Each tabbed page includes a text box that describes the purpose of the page. Each text box also includes a **Help** button. If you need more information on a page, click **Help** to launch the VCX User Interface online Help system.

The following list provides a brief description of the features you can manage on each tabbed page. For detailed information, refer to the online Help. Note that some features must be enabled on the phone after configuration in the VCX User Interface. These features are noted in the list.

■ **Welcome**

- **Welcome** — Provides an initial welcoming page that can include current system information, such as mailbox capacity, and the number of new and saved messages.
- **My Information** — Displays name and address information that you can modify as necessary. Also enables you to change the size of the font used in your telephone's Display Panel.
- **Web Login** — Allows you to change the password you use to access the VCX User Interface.
- **Directory** — Allows you to search a directory of other system users to find name and extension information. The directory can be either local (users whose phones are connected to the same VCX call processor) or global (all the users in a multi-site enterprise that includes regional, branch, and local offices). Search criteria can include first name, last name, extension, or location. If you do not enter search criteria, all users are displayed.

■ **My Extensions**

- **Call History** — Allows you to view the call history for your phone, for example, the calling and called parties, and call duration.
- **Ring Patterns** — Enables you to set distinctive ringing tones to identify the source (inside, outside, or private) of incoming calls. Inside calls are calls that originate from within the VCX network. Outside calls are calls that originate from outside the VCX network. Private calls are anonymous calls or calls with caller ID blocked.

- **Bridge Permissions** — Enables you set up your extension so that up to four other users have permission to transfer their calls to your phone. After configuring bridge permissions through the VCX User Interface, see [Enabling Bridged Extensions](#) for additional information. This feature is not supported on Basic (2101 and 3101) phones.
- **Bridged Phones** — Displays up to four extensions that are bridged to your phone. After configuring mappings through the VCX User Interface, see [Enabling Bridged Extensions](#) for additional information. This feature is not supported on Basic (2101 and 3101) phones.



You should not bridge an extension to a Basic phone (Models 2101 or 3101) because these phones have no programmable access buttons. Therefore, these phones have no way of distinguishing a call to its extension and a bridged call.

- **Button Mappings** — Displays the default function associated with each programmable button on your telephone. If permitted by your administrator, you can assign a new function to a button or assign a new value to a button function. For example, you could reprogram a button to add another personal speed dial, or you could change the number dialed for an existing speed dial button. See [Assigning Access Button Functions Using the VCX User Interface](#) for more information.
- **Registrations** — Lists all phones on which you are currently logged in.
- **Passwords** — Enables you to set the login password for your phone extension. This password is also used for mailbox access and must be synchronized with IP Messaging (see the VCX User Interface online help).
- **Date/Time** — If you log in to a phone in another time zone, you can use this option to update the VCX system with your current time zone information. Also allows you to change the date/time format, which is initially set by your administrator.
- **Calling Features**
 - **Personal Speed Dials** — Allows you to set up personal speed dial codes for up to 9 phone numbers.
 - **System Speed Dials** — Allows you to view the system-wide speed dial numbers configured on your system by your administrator. You

cannot add, modify, or delete a system speed dial number. However, you can export the list to a Microsoft Excel spreadsheet. You can also map a system speed dial number to a button on your phone (see [Assigning Access Button Functions Using the VCX User Interface](#)). See [Dialing System Speed Dial Numbers](#).

- **Call Forwarding** — Allows you to control how the VCX system handles your calls when you do not answer a call, your extension is busy, or your calls are forwarded to another extension. See [Enabling Call Forwarding](#) for additional information.
- **Call Coverage** — Allows you to set your default call coverage point. The configured call coverage point determines the destination of a call that is either not answered in time, or cannot be answered because the destination is busy or unreachable (logged out, or disconnected from the network). The default destination for unanswered calls is voice mail. See [Configuring a Call Coverage Point](#).
- **Selective Ringing** — Enables you to set distinctive ringing tones to identify individual callers.
- **Privacy** — Allows you to control whether the VCX system sends your Caller ID when you make a call. See [Controlling Caller ID](#).
- **Call Restrictions** — Allows you to block incoming and outgoing calls that match specified patterns.
- **Group Features**
 - **Hunt Groups** — Allows you to view the hunt groups you belong to and your current login status for each group. See [Hunt Groups](#).
 - **Page Groups** — Allows you to view the page groups configured on your system. When you dial the group page extension, speakers are activated on the telephones that are members of the group. As you speak into your handset, your voice is broadcast on the activated speakers. See [Paging](#).
 - **Call Pickup Groups** — Allows you to view the call pickup groups you belong to and the other members of these call pickup groups. See [Call Pickup](#).
- **Log Out** — Ends your VCX User Interface session. See [Logging Out](#).

Enabling Call Forwarding

This section describes how to enable and use call forwarding features set up through the VCX User Interface.

You can also configure and enable call forwarding through your phone's Telephone User Interface (TUI). See [Call Forwarding](#).

You can use the VCX User Interface to set:

- How long (in seconds) your telephone rings before the system forwards unanswered calls
- Where you want your call to be forwarded
- The condition (or conditions) that result in the system forwarding a call:
 - **Ring No Answer** — Redirect incoming calls to another destination when your phone rings for a configured time period (the default is 20 seconds).
 - **Busy Line** — Redirect incoming calls to another destination when your phone is busy. If you have multiple lines, busy means that all lines are in use.
 - **All Calls** — Redirect incoming calls to another destination unconditionally. Use this feature when you plan to be away from your phone for an extended period of time. Also referred to as Call Forward Universal.
 - **Fall Back** — Return forwarded calls to your call coverage point if the forwarding destination does not answer. When you enable this Call Forward, Fall Back to Coverage feature, a forwarded call that is not answered at the forwarding destination falls back to your extension's coverage. This call coverage point must be either voice mail or Auto Attendant (the call cannot fall back to another extension or to no coverage; see [Configuring a Call Coverage Point](#)).

For example, a call to extension A gets forwarded to extension B if extension A is busy. Extension A has also enabled the Fall Back option. Extension A receives a call that gets forwarded to extension B. However, extension B is also busy. Instead of sending the call to extension B's coverage point or call forwarding destination, VCX returns the call to extension A's voice mail or Auto Attendant.



You can configure the Call Forward, Fall Back to Coverage feature through the VCX User Interface only. This feature cannot be configured through the Telephone User Interface.

To set up call forwarding, log in to the VCX User Interface, select the **Calling Features** option, then access the **Call Forwarding** tabbed page. Enable the appropriate forwarding conditions and click **Save**.

If you configure and enable any call forwarding option through the VCX User Interface, the option becomes effective the next time your phone registers with the VCX call processor (ask your administrator about registration intervals).



Your administrator may prevent you from configuring Call Forward All, Call Forward Ring No Answer, or Call Forward Busy to an external (outside the enterprise) number. See your administrator for information.

Configuring a Call Coverage Point

A call coverage point determines how the VCX system treats an unanswered call. A call is considered unanswered for the following reasons:

- The call rings and is not answered before the call coverage ring timeout value is reached. The default timeout value is 20 seconds.

Note that Call Forward settings take precedence over Call Coverage Point settings. Furthermore, the Call Forward - Ring No Answer feature also has a ring timeout value. The default timeout value for this feature is also 20 seconds. The Ring No Answer timeout value has priority over the call coverage timeout value. If the Ring No Answer timeout value is greater than the coverage timeout value, the coverage timer is ignored so the call can be forwarded to the Call Forward destination.

- The call cannot be answered because the destination is busy or unreachable (logged out or disconnected from the network).

The default call coverage point is voice mail. However, your administrator can specify a different default for all subscribers, or you can set your own call coverage point. There are four possible call coverage points:

- Voice mail (the default)
- The Auto Attendant
- A telephone number (internal or external)
- No coverage

If the no coverage option is selected and a call is not answered, the caller will hear a busy tone or an error message depending on the reason for the unanswered call.



If you enable Do Not Disturb on your phone, calls will automatically go to the call coverage point, which may or may not be voice mail.

The call coverage point must be set through the VCX User Interface (or the Administrator Interface). It cannot be set through the Telephone User Interface.

Assigning Access Button Functions Using the VCX User Interface

This section describes how to use the VCX User Interface to view, and possibly modify, the VCX features associated with the Access buttons on your telephone.

When a VCX system is configured, your administrator assigns (maps) default functions for the Access buttons on your telephone. Mapping a function to a button allows one-touch access to that function. Speed dialing is one example of a one-touch function.

Your administrator may allow you to reprogram a button's function (for example, create more personal speed dial buttons).

To view the functions currently mapped to buttons on your phone:

- 1 Log in to the VCX User Interface, select the **My Extensions** option, then access the **Button Mappings** tabbed page.
- 2 Choose your telephone model (for example, the Model 3103 Manager'sphone) and click **Select**.



CAUTION: *The VCX User Interface cannot determine your telephone model. You must select the correct model from the drop down list.*

The VCX User Interface displays a graphic of the selected phone model and shows the function mapped to each button. If a function name appears dimmed (light gray text), your administrator has locked that function-button mapping and you cannot remap it. See the online help for more information.

Enabling Bridged Extensions

This section describes how to enable and use bridged extensions set up through the VCX User Interface.

The VCX system allows you to set up your extension so that other users can receive your calls at their phones. Through the VCX User Interface, you can grant permission to up to four other users to receive calls intended for your extension; that is, you are “bridging” your extension to their phones.

The bridged phone is sometimes referred to as the primary phone. The phone receiving bridged calls is sometimes referred to as the secondary phone.

A bridged extension is typically used by an administrative assistant (the secondary phone) to accept calls for one or more managers (primary phones). Or one manager (primary phone) may be monitored by multiple assistants (secondary phones). The primary phone and the secondary phone (or phones) can be located at different sites.

Bridging an extension requires three steps:

- 1 On the phone whose extension you want to bridge (for example, extension 1000):
 - a Log in to the VCX User Interface, select the **My Extensions** option, then access the **Bridge Permissions** tabbed page.
 - b Specify the extension (for example, extension 1001) that you want to receive a bridged call and click **Add**.



The bridged phone can identify up to four phone numbers to bridge with, but the number of extensions it can actually bridge is determined by the maximum number of contacts that the system administrator has set up for the phone, which may be fewer than four.

- 2 On the phone that will receive a bridged call (in this example, extension 1001):
 - a Log in to the VCX User Interface, select the **My Extensions** option, then access the **Button Mappings** tabbed page.
 - b Map the bridged extension (in this example, extension 1000) in the Bridged Extension 1/2 box and click **Save**.



You should not bridge an extension to a Basic phone (Models 2101 or 3101) because these phones have no programmable buttons. Therefore, a Basic phone has no way of distinguishing a call to its extension and a bridged call.

- 3 For the bridged line settings to take effect, the phone must retrieve the new settings from the VCX server. By default, phones check the VCX server for new information every 60 minutes (the phone registration interval). To retrieve bridged line settings, you can use one of the following options:
 - Wait for the phone registration interval to expire (60 minutes or less, depending on when the last registration occurred).
 - Log off and then log on to the phone.

In this example, an incoming call to extension 1000 will also ring on extension 1001.

The primary phone user can make calls on a bridged line. The secondary phone user can answer calls that are made to the primary phone's extension. Both users can use VCX features to manage bridged calls. For example, bridged calls can be transferred, put on hold, or forwarded to voice mail. However, because multiple phones are involved, you should note the considerations discussed in [Bridged Line Interaction with Other Features](#).

Both primary and secondary users can be logged in to multiple phones. For example, an administrative assistant (secondary user) can be logged in to four phones and monitor a manager from any phone as long as all the secondary phones are configured with the same extension. Or, a manager may be logged in to multiple phones and monitored by an assistant logged in to one or more phones. In any case, the total number of logged in primary and secondary phones cannot exceed five.

For the current release, the primary and secondary phone (or phones) must be located on the same site.

Your administrator can also set up bridged extensions. In this case, fields on your **Bridge Permissions** and the **Button Mappings** tabbed pages have preassigned values.

Bridged Line Interaction with Other Features

Calls to a bridged extension can be managed by a primary user or a secondary user, like non-bridged calls. For example, bridged calls can be parked, put on hold, transferred, or conferenced.

A call to a bridged extension can be affected by call coverage points, call forwarding settings, and Do Not Disturb settings on the primary and secondary phones.

Calls to a bridged extension that are not answered always follow the call coverage point configured for the primary phone, or, if call forwarding is enabled, the appropriate call forward setting for the primary phone.

Topics in this section describe how bridged calls are handled when certain VCX features are invoked by the primary phone user, the secondary phone user, or both users.

Do Not Disturb and Bridged Line Calls

If the primary phone enables Do Not Disturb and a call rings on a secondary phone, there is no call indication on the primary phone—the phone does not ring. Once the call is answered or put on hold, the primary phone's handset icon in the Display Panel show on hold.

- If the primary phone enables Do Not Disturb, a call goes directly to the primary phone's call coverage point if:
 - All secondary phones have enabled Do Not Disturb
 - No secondary phone is available
- If the primary phone enables Do Not Disturb and no secondary phone answers the call, the call goes to the primary phone's Call Forward destination when the Call Forward - Ring No Answer ring timeout value is reached.
- If a secondary phone enables Do Not Disturb and other secondary phones are available (or the primary phone is available), the call rings on one of the other phones.
- If a secondary phone enables Do Not Disturb and no other secondary phones are available, the call rings on the primary and there is no indication of the call on the secondary phone.
 - If the primary does not answer, the call goes to the primary phone's Call Forward destination when the Call Forward - Ring No Answer ring timeout value is reached.
 - If the primary does answer or put on hold, the secondary phone does indicate call status.

If neither the primary phone or the secondary phones have Do Not Disturb enabled, a call rings on both phones.

- If the primary phone user presses the DND button while the call is ringing, it stops ringing but continues to ring on the secondary. If the secondary does not answer, the call goes to the primary phone's Call

Forward destination when the Call Forward - Ring No Answer ring timeout value is reached.

- If the secondary phone user presses the DND button while the call is ringing, it stops ringing but continues to ring on the primary. If the primary phone does not answer, the call goes to the primary phone's Call Forward destination when the Call Forward - Ring No Answer ring timeout value is reached.
- If the primary and secondary phone users both press the DND buttons while the call is ringing, it stops ringing on both phones. The call goes to the primary phone's Call Forward - Busy destination.

If the primary phone enables Do Not Disturb, a call rings on a secondary phone. If the primary phone user disables Do Not Disturb while the call is ringing, the call does not start ringing on the primary. Do Not Disturb is enabled only for subsequent calls. This is also true for a secondary phone user who toggles the Do Not Disturb setting while a call is ringing.

If the primary phone enables Do Not Disturb and a call comes in from a hunt group, the Do Not Disturb setting is ignored and the call rings on the primary. If a secondary phone enables Do Not Disturb and a call comes in from a hunt group to the primary phone, the call does not ring on the secondary phone.

Hands Free and Bridged Line Calls

Enabling the Hands Free feature has the following effect on bridged calls:

- If the primary phone has Hands Free enabled, a call rings briefly on the secondary phone before it is automatically answered by the primary phone.
- If the secondary phone has Hands Free enabled, only calls made to the secondary's phone extension are answered Hands Free. Calls to primary phone are not answered Hands Free on the secondary phone; they appear as normal bridge calls.

Call Forward, Forward to Voice Mail, and Bridged Line Calls

Enabling Call Forwarding and Forward to Voice Mail (or enabling both features) has the following effect on bridged calls:

- If the primary phone enables Forward to Voice Mail, calls ring once on the primary and secondary phones, and then go to voicemail.

- If the primary phone enables Call Forward Universal, calls to the primary go to the Call Forward Universal destination immediately and do not ring on the primary or secondary phones.
- If a secondary phone enables Forward to Voice Mail or Call Forwarding to another extension, these settings affect only calls to the secondary phone extension. A bridged call rings on both the primary phone and secondary phone.
- If a call is ringing on the primary phone and the secondary phone, and the primary phone user presses the Forward to Voicemail button, the call is forwarded to primary phone's voice mailbox and the secondary phone stops ringing.
- If a call is ringing on the primary phone and the secondary phone, and the secondary phone user presses the Forward to Voicemail button, call will continue ringing on both phones.

Call Transfer, Call Conferencing, and Bridged Line Calls

Bridged calls can be transferred by either the primary phone or the secondary phone. The primary phone user and secondary phone user can also set up a conference with a bridged call.

If the primary phone is on a bridged call and presses the **Transfer** button, the primary phone user hears a dial tone. The user can then enter a telephone number to start attended or unattended call transfer. While the primary phone user enters the phone number, the calling party is put on hold. However, the light for BSA line on the secondary phone remains on (does not blink as it would for a non-bridged call on hold).

While on a bridged call, the primary phone user can also press a free SA line to transfer the call from a BSA line to a SA line. Or, a call connected on a SA line can be transferred from the SA line to its BSA line. A secondary phone user, however, can only transfer a call from an SA line to BSA line but cannot transfer a bridged call to an SA line.

Both primary and secondary phones can set up a 3-way conference call on a bridged line.

Call Park and Bridged Line Calls

Either the primary phone user or the secondary phone user can park a call.

When either a primary or secondary phone user parks a call and the call park timeout value is reached (the default is 5 minutes), the parked call rings back only on the phone that parked the call. For example, if a primary phone user parks a bridged call to a Call Park extension and no one picks up the parked call, after 5 minutes the parked call rings back only on the primary phone that parked the call. The call does not ring back on a secondary phone or on any other primary login instance. When the primary phone answers the call, the status light on primary phone lights but the status lights on the bridged phones do not light.

If all lines are in use, a parked call that rings back is forwarded according to the enabled Call Forwarding setting for that phone. If Do Not Disturb is enabled, the parked call is forwarded to the call coverage point configured for that phone.

Call Pickup and Bridged Line Calls

Call Pickup (both Directed and Group) allows a user to answer a call that is ringing on another telephone.

For bridged calls, you enter the Call Pickup feature code (455 for Directed; 456 for Group) followed by the group security code and the extension of a primary phone. The call stops ringing on all primary and secondary phones when the call is picked up. You cannot enter the extension of a secondary phone. Doing so returns an error, and the call keeps ringing on all primary and secondary phones.

Attendant Console and Bridged Line Calls

The VCX administrator can map primary phone numbers and secondary phone numbers to buttons on a VCX 3105 Attendant Console. In this case, status lights on the Attendant Console show that the bridged line is in use for primary and secondary phones.

Hunt Groups and Bridged Line Calls

A primary or a secondary phone can belong to a hunt group.

If a primary phone is a member of a hunt group, a call coming to the hunt group rings on an SA line on the primary phone. A secondary phone cannot receive a hunt group call directed to a primary phone.

Message Waiting Indication and Bridged Line Calls

A secondary phone displays the Message Waiting Indication (MWI) of the primary phone (or phones).

Pressing the **MSG** button lists the mailboxes. You can press Up and Down arrow keys to select a mailbox, then press the **MSG** button again to connect to that mailbox.

Personal Speed Dial Access Buttons

The VCX User Interface allows you to set up personal speed dial access buttons using two method; by assigning the **Personal Speed Dial** feature to an access button and by assigning the **Call** feature to an access button.

Using the Personal Speed Dial feature provides up to five personal speed dial numbers that you can assign. Using the Call feature provides an additional three personal speed dial numbers you can assign.

Logging Out

To log out of the VCX User Interface, follow these steps:

- 1 From any screen, click the **Log Out** button just above the copyright notice.
The **Login** screen appears.
- 2 Close your web browser.

7

VCX ATTENDANT CONSOLES — MODEL 3105 AND COMPLEMENT ATTENDANT

The VCX Attendant Console (Model 3105) and the VCX Complement Attendant Software (CAS) application enable a receptionist to handle high call volumes efficiently. Although receptionists are the primary users of the Attendant Console and the CAS, the two can also be used by busy sales representatives and others who receive a high volume of telephone calls or who make frequent calls to the same telephone numbers.

This chapter includes the following topics:

- [VCX Attendant Console](#) — A device that works along with VCX telephones to increase call handling capability. In many offices, the Attendant Console is used by a receptionist or switchboard operator, who is referred to in this guide as “the receptionist.”
- [Complement Attendant Software](#) (CAS) — A software application, installed by an administrator, that allows a receptionist to answer and route calls using a personal computer.

The Attendant Console and VCX Complement Attendant Software application can be used at the same time. However:

- When incoming calls appear on the Attendant Console, you must handle them using the buttons of the console.
- When calls appear on the CAS computer screen, you must handle them using the mouse and the CAS software features.

VCX Attendant Console

The VCX 3105 Attendant Console has 50 Access buttons and 4 preprogrammed Feature buttons. In effect, the Attendant Console is an extension of the VCX Business Telephone or VCX Basic Telephone with which it is associated.

[Figure 4](#) illustrates the buttons and controls on the VCX 3105 Attendant Console.

Access Buttons

The 50 Access buttons on an VCX 3105 Attendant Console can each have two sets of assignments: 1 through 50, and 51 through 100. To toggle between the two sets of assignments, press the **Shift** button.

Your administrator can assign features to each Access button. Possible features include:

- Status of internal telephone extensions (busy, available)



In the current release, when you assign a phone extension to an Attendant Console button, the button assignment does not become effective until either the Attendant Console is rebooted or the phone registration interval elapses. The default registration interval is one hour (3600 seconds).

- Status of external telephone lines
- Speed dials for user extensions:

Feature Buttons

The four **Feature** buttons are programmed for four of the five most common features needed by a receptionist: Call Transfer, Call Hold, Conference, Call Park, or Attendant Serial Call. The **Shift** button does not affect the operation of the Feature buttons. Your administrator configures the feature assigned to a particular Feature button using the VCX User Interface, Central Management Console. The feature-to-button mappings described in the list following [Figure 4](#) are the defaults and may not correspond to your configuration.

Your administrator also maps telephone extensions to Access buttons using the VCX Administrator web interface.

[Figure 4](#) and the text that follows it describe the features on the VCX 3105 Attendant Console.

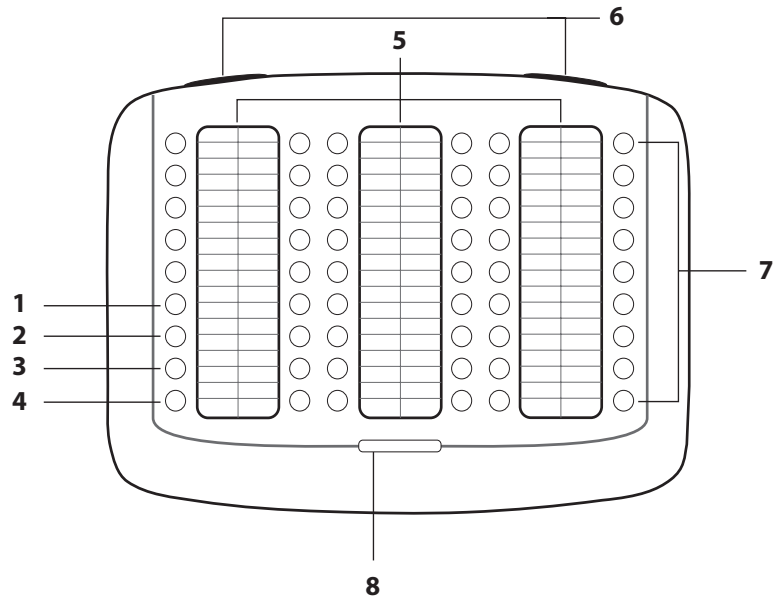
Figure 4 VCX 3105 Attendant Console

- 1 Transfer button** — Enables you to send a call to another telephone. See [Transferring a Call](#).
 - 2 Hold button** — Places a caller on hold. See [Putting a Call on Hold](#).
 - 3 Conference button** — Allows you to set up a three-way conference call. See [Setting up a Conference Call](#).
 - 4 Call Park button** — Places a call in a “holding pattern” so that it can be retrieved from any other telephone on the system. See [Call Park](#).
- Attendant Serial Call button** — Enables you to send a call to another telephone like Transfer, but the call rings back to you when the destination hangs up. You can perform another transfer or other action. Not mapped to a button by default, your administrator can map Attendant Serial Call to any of the four buttons. See [Serial Transfer](#).
- 5 Labels** — You can print labels for your Attendant Console using the LabelMaker utility, which is available through the 3Com web site. See [Printing Labels](#).
 - 6 Label cover tabs** — Allow you to unsnap the plastic cover to insert labels.

- 7 Access buttons** — If your administrator has mapped an extension to an Access button, a light next to the button indicates whether the line is available or in use, or whether an assigned feature is enabled. See [Attendant Console Status Lights](#).

Your administrator uses the VCX Administrator web interface to map telephone extensions to **Access** buttons numbers. The interface numbers each button. For example, the administrator may say that extension 4001 is assigned to button 1, extension 4002 is assigned to button 2, and so on. On the Attendant Console, the buttons are numbered from top to bottom, starting in the top left corner. (However, no number physically appears next to a button.)

- The first five buttons from the top in the left column correspond to **Access** buttons 1 through 5. (The bottom four buttons are always the **Feature** buttons.)
 - The second column of nine buttons correspond to **Access** buttons 6 through 14.
 - The third column of nine buttons correspond to **Access** buttons 15 through 23.
 - The fourth column of nine buttons correspond to **Access** buttons 24 through 32.
 - The fifth column of nine buttons correspond to **Access** buttons 33 through 41.
 - The sixth column of nine buttons correspond to **Access** buttons 42 through 50.
- 8 Shift button** — Enables you to toggle between the two sets of Access button assignments on the Console. Press the **Shift** button to switch between assignments 1 through 50 and assignments 51 through 100. The **Shift** button LED is lighted when you have buttons 51 through 100 selected.

Printing Labels To create, print, and save labels for your Attendant Console (or any VCX telephone):

- 1 Access the 3Com web site, <http://www.3com.com>.
- 2 Click **Support & Downloads** and select **Downloads & Drivers** from the drop-down list box.
Your browser displays the Downloads page.
- 3 On the Downloads page, select the following options:

- a In the **Criteria-base Search** section, in the **Type of File** list box, select **Documentation**.
 - b In the **Product Category** list box, select **Convergence/IP Telephony**.
 - c In the **Filename** text box, enter **labels.exe**.
 - d In the **Operating System** list box, select **All**.
 - e Click **Search**.
- 4 When the search results page is displayed, locate the **labels.exe** file for 3Com VCX V7000 IP Telephony Solution, and download it to your system. (Do not download any of the labels.exe files for the NBX product.)
 - 5 Locate labels.exe on your system and double-click the file icon to start the LabelMaker program.
 - 6 Find the page in the LabelMaker that has labels for your attendant console.
 - 7 Edit the label template by clicking any of the label text boxes to highlight the existing text, and then typing new text.
 - 8 Press **Tab** to move to the next text field in the label.
 - 9 Click the **Print** button at the top of the LabelMaker screen to open the Print dialog. Specify which page you want to print. Typically, the default is to print all pages.
 - 10 Click **Print**.
 - 11 Cut out the labels and put them in the label holders of your attendant console.
 - 12 To save the edited LabelMaker, click the **Save** button at the top of the LabelMaker screen. Or you can click **File > Save As** to save the LabelMaker to a new location.



To reuse your saved LabelMaker, run the file that you saved to your computer. If you download the LabelMaker from the 3Com web site, you always get the default version. If you save the default version to the same place you saved an earlier edited version, you overwrite the earlier version.

Attendant Console Status Lights

An Access button that is set up for incoming and outgoing calls is called a System Appearance button. The light beside each System Appearance button indicates its status. See [Table 6](#).

Table 6 Status Indicator Lights for System Appearance Buttons

If the light is	The line is
Off	Available for use
Steady	In use
Blinking	Do Not Disturb is enabled
Blinking quickly	Dialing an emergency call

Complement Attendant Software

The Complement Attendant Software (CAS) application is an optional VCX component, which requires a license. On your personal computer, the Complement Attendant Software displays your telephone directory in a series of tabs. Each tab sorts the directory by a different type of information, for example, by last name, by department, or by extension.

[Figure 5](#) shows the Complement Attendant Software main window.

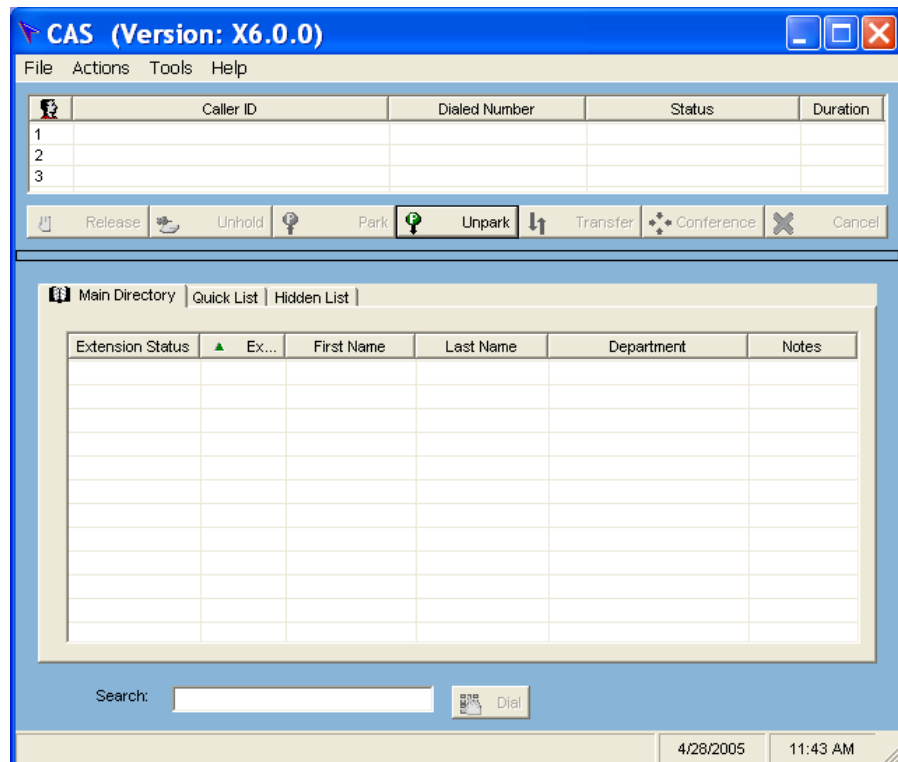
Figure 5 Complement Attendant Software Main Window

The main window includes three areas:

- The Call List appears on the top part of the window and displays currently active calls. See [Table 7](#).
- The Command Buttons appear below the Call List and perform operations on a selected call. See [Table 8](#).
- The Directory List appears on the bottom of the window and lists phone extensions and users in the system directory. See [Table 7](#).

The Call List and Command Buttons are separated from the Directory List by a horizontal bar that allows you to resize the lists. This is very useful if you want to display more of the Call List and less of the Directory List.

To resize the lists, move the mouse pointer over the horizontal bar. The pointer changes to a double-ended arrow. Press the left mouse button and drag the bar up or down the screen.

When you answer a call using the Complement Attendant Software, you can select a user from the directory and transfer the call to that user.

[Table 7](#) describes the main elements of the Call List and Directory List areas.

Table 7 Elements of the Complement Attendant Software Screens

Field	Purpose
Call List	Displays Caller ID information (name and extension number), the status of a call, and the duration of the call. The number of calls displayed depends on the number of access lines that you have specified in your general settings.
Find/Phone# Display	Provides the extension number and name of the person selected in the directory.
Clear Button	Cancels previous criteria.

Table 7 Elements of the Complement Attendant Software Screens (continued)

Field	Purpose
Main Directory tab	<p>Displays all the entries in the Directory List.¹</p> <p>Extension Status — Sorts the data in the directory by extension status.</p> <p>Extension — Sorts the data in the directory by listing the extension numbers in ascending order.</p> <p>First Name — Sorts the list of users in alphabetical order by first name.</p> <p>Last Name — Sorts the list of users in alphabetical order by last name.</p> <p>Department — Sorts the directory by the user department.</p> <p>Notes — Sorts the directory by note entries.</p>
Hidden List tab	Hides entries in the VCX directory that you do not want to appear on other tabs, such as conference room phones.
Quick List tab	Provides access to frequently used entries in the directory.

¹ If your VCX system includes multiple sites (for example, regional and branch offices), each with one or more VCX call processors, CAS can display a global directory of all the users in your organization. Note that this option must be configured by your administrator. By default, CAS displays the local user directory.

The Complement Attendant Software provides a Line Monitoring feature similar to the Busy Lamp Field (BLF) feature available on the VCX Attendant Console. Line Monitoring allows you to monitor the busy status of other phones. This feature is very useful for determining if someone is on the phone prior to transferring a call to that person.

[Table 8](#) describes Command Buttons, and the keyboard shortcuts to functions on the Action menu. Note that [Figure 5](#) does not show all the possible buttons because there are no active calls.

Table 8 Complement Attendant Software Buttons and Keyboard Shortcuts

Button	Purpose	Keyboard Shortcut
Answer/Release	Answers an incoming call.	Alt+A
	Terminates a call.	Alt+R
Hold/Unhold	Places a caller on hold.	Alt+H
	Removes a caller from being on hold and returns to the call.	Alt+N

Table 8 Complement Attendant Software Buttons and Keyboard Shortcuts

Button	Purpose	Keyboard Shortcut
Park	Places a call in a "holding pattern" so that it can be retrieved from another telephone on the system.	Alt+K
Unpark	Releases a caller from a "holding pattern."	Alt+U
Transfer	Forwards a call to another telephone.	Alt+T
	Completes the transfer of a call.	Alt+M
Conference	Enables three subscribers to participate in a single call.	Alt+C
	Completes the conference call.	Alt+P
Cancel	Cancels a transfer.	Alt+S
	Cancels a conference call.	Alt+E
Dial	Dials a selected number to place an outgoing call.	Alt+D

For complete information on the Complement Attendant Software, see the online Help system in the software.

A

TELEPHONE INSTALLATION AND MAINTENANCE

This chapter covers these topics:

- [Connecting the Telephone](#)
- [Opening the 3105 Attendant Console Label Cover](#)
- [Moving Your Telephone](#)
- [Swapping Telephones](#)
- [Cleaning Your Telephone](#)
- [Troubleshooting Problems](#)

Connecting the Telephone

Although the connector layout varies between telephones, all VCX telephones and attendant consoles use these symbols to identify the connectors:

Power connection for an AC power adapter.



Network connection. Connects the device to the network. A powered Ethernet cable that conforms to the Power over Ethernet (IEEE 802.3af) standard is acceptable for:

- 3Com 3101 Basic Telephones
- 3Com 3102 Business Telephones
- 3Com 3103 Manager's Telephones
- 3Com 3105 Attendant Consoles
- Older 3Com telephones that include "PE" in the part number.



Switch port for connecting a computer or other network device, such as an VCX Attendant Console, to the network.



Handset connector.



Headset connector. Model 3102 and Model 3103 only.

[Figure 6](#) shows underside of the VCX 3102 Business Telephone as an example of possible connection points. Connection details for each type of VCX device are listed on the packing sheet that is shipped with the device.

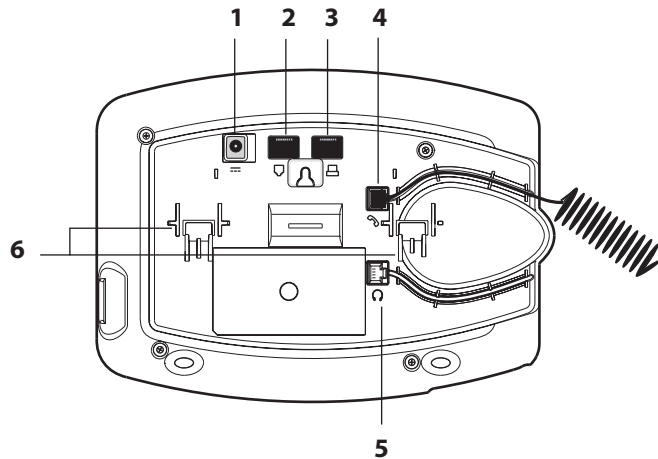
Figure 6 Underside of the VCX 3102 Business Telephone

CAUTION: The VCX system operates over the LAN, not through traditional telephone wiring. Your telephone connects to the VCX system through an RJ-45 LAN connector instead of an RJ-11 telephone connector. Your telephone will not work unless it is connected properly. Ask your administrator if you have questions about your telephone connection.

The underside of an VCX telephone or attendant console includes:

- 1 AC power adapter connection
- 2 Ethernet connector for connection to the LAN
- 3 Ethernet connector for an optional connection to your desktop computer.
- 4 Handset connector
- 5 Headset connector (3102 and 3103 only)
- 6 Tabs for the support bracket



For information about the underside of each VCX Telephone, and for information about how to connect any VCX Telephone or Attendant Console to a Power over Ethernet source, see the packing sheet that comes with the device.

Strain relief clamps are built into the 3101/3102/3105 support bracket.

Attaching and Adjusting the Articulating Support Bracket

The articulating support bracket is common to the following devices:

- 3Com 3105 Attendant Console
- 3Com 3103 Manager's Telephone

[Figure 7](#), [Figure 8](#), and [Figure 9](#) show a 3102 Telephone. The instructions apply to all telephones.

Figure 7 Attaching the Support Bracket

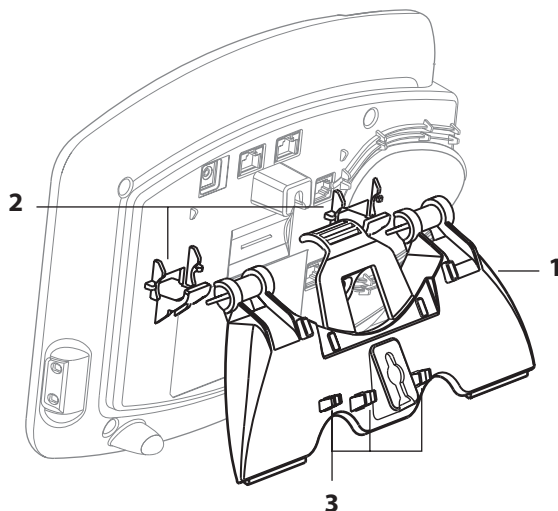

To attach the support bracket, **1**, snap the bracket into the mounting supports **2**, on the bottom of the telephone.

After you connect the cables to the phone, press the cables into the cable management clamps **3**, on the stand.

Figure 8 Adjusting the Support Bracket

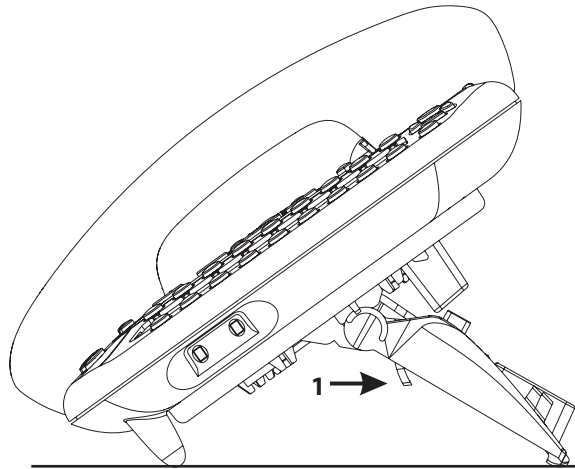

To adjust the support bracket, press to release the lock tab **1**, rotate the bracket to the position that you want, and then release the lock tab.

Figure 9 Wall Mounting a 3102 Telephone

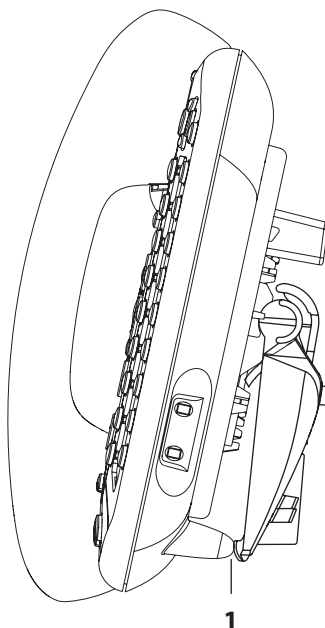

When you mount a 3101, 3101SP, 3102, or 3103 telephone on a wall, attach the support bracket and adjust it so that the bottom of the support bracket rests against the bottom supports on the telephone, **1**.

Safe wall mounting requires 3/4-inch drywall and 1.5-inch drywall screws.

Opening the 3105 Attendant Console Label Cover

For instructions on how to create and print labels, see [Printing Labels](#) on [page 98](#).

Figure 10 3105 Attendant Console Label Cover Tabs

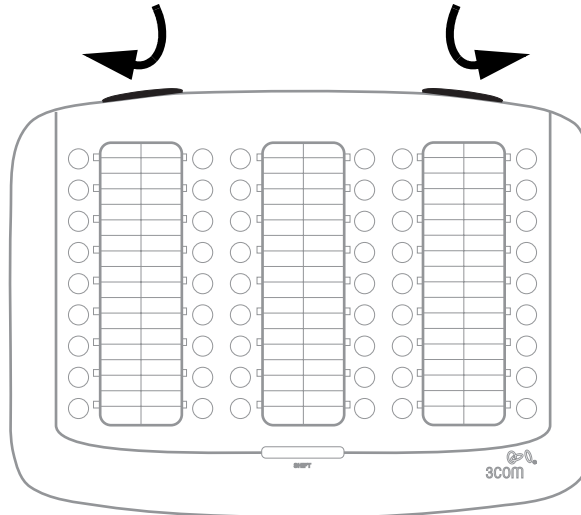

After you print the labels and then cut them out, remove the plastic cover from the Attendant Console by pulling up on the two tabs at the top of the Attendant Console until the top of the cover pops off.

Moving Your Telephone

Each VCX telephone is uniquely identified by an IP address. You can move your telephone to another location within your calling domain, connect it to any Ethernet jack on the LAN, and still maintain all of your personalized features, speed dials, and extension number.

Swapping Telephones

Your administrator assigns a password for your telephone. This password associates your telephone extension (and mailbox) with your account. This may allow you to configure another VCX phone in the system to duplicate your primary phone. This means if you are away from your primary phone (for example, in a different office), you can program the local phone to use your extension. Any calls made to your extension will ring in both locations and you can access your mailbox from either phone. See the overview section in the chapter that describes your telephone for more information.

Cleaning Your Telephone

Always unplug your telephone from the power source and from the network before you clean it. Use a soft cloth dampened with mild detergent.



WARNING: Failure to unplug the telephone before you clean it could result in electrical shock.

Troubleshooting Problems

[Table 9](#) lists possible problems that you may encounter and the most likely solutions. Where possible, each solution refers to the section in this guide where you can find detailed information.

Table 9 Possible Problems

Possible Problem	Suggested Solutions
My telephone has no dial tone and the display panel is blank.	<ul style="list-style-type: none"> ■ Verify that the power cord is fully inserted in the correct connector on the underside of the telephone. Use the strain relief tab to prevent the cord from becoming unplugged. ■ Verify that the Ethernet cables are connected and that each cable is in the proper connection. ■ Remove and add power to the telephone by unplugging the power cord at the electric outlet and plugging it back in. ■ If the telephone is powered through a powered Ethernet cable, make sure that power is applied to the cable at its source.
My telephone has "locked up."	<ul style="list-style-type: none"> ■ Your telephone has lost the connection to the system. Remove the Ethernet cord from the jack, and then re-insert it into the jack. ■ Wait a few seconds. If the telephone display panel still appears to be locked, disconnect the electrical power for your telephone, and then plug it back in.
Callers cannot leave messages on my voice mail.	Your mailbox may be full. Log in to your voice mailbox and delete some messages.
When I dial 9 or 8 to access an outside line, the display panel shows "All Ports Busy."	No outside lines are available. Try again in a few minutes.
After I call another user in my organization, I hear a tone but no ringing.	The other user may have the Hands Free feature enabled. Begin speaking after you hear the tone. For details, see Using the Hands Free Feature .

Table 9 Possible Problems (continued)

Possible Problem	Suggested Solutions
On my VCX Business Telephone, all incoming internal calls come over my speaker phone.	You have the Hands Free feature enabled. For details, see Using the Hands Free Feature .
My telephone is not forwarding my incoming calls to my voice mailbox.	Verify that you have activated the Forward to Voice Mail feature. For details, see Forwarding Calls to Voice Mail .
On my VCX Business Telephone, I added a One-Touch speed dial, but the telephone does not dial that number.	Verify that you have correctly set up speed dialing. For details, see Speed Dialing .
My telephone keeps ringing after I pick up the handset.	<ul style="list-style-type: none"> ■ Your telephone may have lost connection to the system immediately after a call came in. Remove the Ethernet cord from the jack, then re-insert it into the wall jack. ■ Wait a few seconds. If the telephone continues to ring, disconnect the electrical power for your telephone, and then plug it back in.
The display panel shows "Wait for NCP."	Your telephone may be disconnected from the system. Hang up your telephone and wait a few seconds. Then pick up the handset. If the message still appears on your telephone display panel, contact your administrator.

INDEX

Numbers

- 3105 Attendant Console 95
 - creating labels 98
 - figure and features 97
 - overview 96

A

- accessing the VCX User Interface 80
- all calls (call forwarding)
 - set through VCX User interface 84
- All Ports Busy message 112
- answering a call 28

B

- Barge In 69
- bracket
 - 3103, telephone support 108
- bridging extensions
 - enabling 86
- busy line (call forwarding)
 - set through VCX User interface 84
 - set with a feature code 63

C

- call coverage
 - forwarding calls to 85
- call fallback (call forwarding) 84
- call forward
 - problems with 113
- call forwarding
 - all calls 63, 84
 - busy line 63, 84
 - ring no answer 62, 84
 - setting up 83
- call history
 - through the VCX User Interface 81
 - viewing 52
- call park 64
- call pickup 66
 - feature interaction 67
- call waiting 58

- Caller ID
 - sending or blocking 53
- caller ID
 - controlling 86
- calling Hunt Group 74
- calls
 - answering 28
 - answering a second call 37
 - answering for a group 66
 - answering for another user 66
 - camp on 55
 - dialing a second call 37
 - dropping 32
 - forwarding to call coverage 85
 - forwarding to voicemail 57
 - forwarding using feature codes 62
 - forwarding using the VCX User interface 83
 - holding 36
 - making 29
 - missed 33
 - muting 39
 - parking 64
 - redialing 30
 - tracing a malicious call 41
 - transferring 37
- camp on 55
- circular Hunt Group 74
- Class of Service
 - overriding 31
- cleaning telephones 112
- Complement Attendant Software 95
 - buttons and keyboard shortcuts 102
 - features 100
 - interface 101
- conference call
 - announced 55
 - setting up 54
 - unannounced 55
- configuration
 - interface options 14
- connecting telephones
 - caution, RJ-45 versus RJ-11 jacks 107
 - electrical power 106
- contrast 23

D

dial tone, troubleshooting an NBX Telephone 112
dialing a remote office
 using a site code 31
 using a unique extension 30
dialing while on a call 37
directed call pickup 66
directory of users
 global 52
 local 52
display panel
 contrast 23
 soft keys 18
 using 52
Do Not Disturb
 activating 40
dropping calls 32

E

electrical shock, avoiding 112
extensions
 bridging 86

F

feature codes 44
forward universal (call forwarding)
 set through VCX User interface 84
 set with a feature code 63
forwarding a call to a remote location 71
forwarding calls 62, 83

G

global user directory 52
group call pickup 66
group paging 65

H

hands-free
 using 35
headset
 retuning after a long delay 36
 using (3102, 3103 phone only) 35
holding a call 36
Hunt Groups
 access numbers 73
 calling 74
 circular 74
 feature code 78

feature interaction 77
linear 74
logging in 76
overview 72
timeout values 75
types 74
viewing membership and status 78

J

joining a monitored call 69

L

linear Hunt Group 74
local user directory 52
logging in 26

M

mailbox
 setup 13
making calls 29
Malicious Call Trace 41
mapping button functions 86
missed calls 33
monitoring calls 68
 barging in 69
moving telephones 111
music on hold 36
mute ringer 39
muting calls 39

O

one-touch speed dials 58
overview 12

P

paging 65
parking a call 64
password 26
 changing 27
 for telephone and mailbox access 82
 for VCX User Interface 80
 changing 81
personal speed dials 58
phone settings
 transferring to another phone 56
problems
 solving 105

R

redialing 30
 registrations
 through the VCX User Interface 82
 relocating telephones 111
 Remote Call Forward 71
 ring no answer (call forwarding)
 set through VCX User interface 84
 set with a feature code 62
 ring patterns
 setting through the VCX User Interface 81
 RJ-11 jack caution, avoiding use with VCX
 telephones 107
 RJ-45 jack caution, using instead of RJ11 107

S

selective ringing
 setting through the VCX User Interface 83
 Silent Monitor 68
 blocking 70
 site codes 31
 soft keys 18
 speaker phone
 problems with 113
 using 30
 speed dialing 58
 configuring personal numbers 59
 dialing personal numbers 61
 dialing system numbers 62
 editing personal numbers 61
 one-touch 58
 personal 58
 system 59
 viewing configured numbers 62
 speed dials
 problems with 113
 support brackets
 3103, attaching 108
 3105, attaching 108
 system speed dials 59

T

telephone support brackets
 3103 108
 3105 108
 telephones
 cleaning 112
 connecting 106
 logging in 26
 mounting 3105 108

 mounting, 3103 108
 moving and swapping 111
 passwords 26
 time zone
 setting through the VCX User Interface 82
 transferring a call 37
 attended 38
 serial 38
 unattended 37
 troubleshooting
 list of possible problems 112

U

user directory
 through the VCX User Interface 81
 user directory (global)
 viewing 52
 user directory (local)
 viewing 52

V

VCX 3105 Attendant Console
 see 3105 Attendant Console
 VCX Complement Attendant Software
 see Complement Attendant Software
 VCX User Interface
 accessing 80
 logging out 93
 set up selective ringing 83
 setting ring patterns 81
 setting the time zone 82
 viewing call history 81
 viewing phone registrations 82
 viewing the user directory 81
 voice mail
 problems with 112
 volume
 controlling 34

W

Wait for NCP message 113

Z

zone paging 65

Free Manuals Download Website

<http://myh66.com>

<http://usermanuals.us>

<http://www.somanuals.com>

<http://www.4manuals.cc>

<http://www.manual-lib.com>

<http://www.404manual.com>

<http://www.luxmanual.com>

<http://aubethermostatmanual.com>

Golf course search by state

<http://golfingnear.com>

Email search by domain

<http://emailbydomain.com>

Auto manuals search

<http://auto.somanuals.com>

TV manuals search

<http://tv.somanuals.com>