

MVME956AC VME Chassis User's Manual

MVME956ACA/UM2

Notice

While reasonable efforts have been made to assure the accuracy of this document, Motorola, Inc. assumes no liability resulting from any omissions in this document, or from the use of the information obtained therein. Motorola reserves the right to revise this document and to make changes from time to time in the content hereof without obligation of Motorola to notify any person of such revision or changes.

No part of this material may be reproduced or copied in any tangible medium, or stored in a retrieval system, or transmitted in any form, or by any means, radio, electronic, mechanical, photocopying, recording or facsimile, or otherwise, without the prior written permission of Motorola, Inc.

It is possible that this publication may contain reference to, or information about Motorola products (machines and programs), programming, or services that are not announced in your country. Such references or information must not be construed to mean that Motorola intends to announce such Motorola products, programming, or services in your country.

Restricted Rights Legend

If the documentation contained herein is supplied, directly or indirectly, to the U.S. Government, the following notice shall apply unless otherwise agreed to in writing by Motorola, Inc.

Use, duplication, or disclosure by the Government is subject to restrictions as set forth in subparagraph (c)(1)(ii) of the Rights in Technical Data and Computer Software clause at DFARS 252.227-7013.

Motorola, Inc.
Computer Group
2900 South Diablo Way
Tempe, Arizona 85282

Preface

The *MVME956AC VME Chassis User's Manual* describes the installation, configuration, and operation of the Model MVME956 chassis. This chassis is a member of a family of system enclosures that are configurable with a variety of card cage, storage drive, and AC power supply options. The MVME956AC is a 12-slot model designed for rack-mount or lab benchtop applications. The manual supplies general information on the chassis, instructions for its preparation and installation, and support information.

This manual is intended for anyone who wants to design OEM systems, supply additional capability to an existing system, or use the equipment in a lab environment for experimental purposes.

A basic knowledge of computers and digital logic is assumed.

Technical knowledge of energy and voltage hazards present in line connected electronic equipment is assumed.

To use this manual, you may need to be familiar with the publications listed in the following *Related Documentation* section.

If any modifications are made to a MVME956AC chassis, the modifier assumes responsibility for radio frequency interference issues. If any payload installed in a Model MVME956AC system is not totally supported by Motorola, the integrator assumes responsibility for radio frequency interference.

Motorola® and the Motorola symbol are registered trademarks of Motorola, Inc.

All other products mentioned in this document are trademarks or registered trademarks of their respective holders.

© Copyright Motorola, Inc. 1997, 1998
All Rights Reserved

Printed in the United States of America
October 1998

Safety Summary

Safety Depends On You

The following general safety precautions must be observed during all phases of operation, service, and repair of this equipment. Failure to comply with these precautions or with specific warnings elsewhere in this manual violates safety standards of design, manufacture, and intended use of the equipment. Motorola, Inc. assumes no liability for the customer's failure to comply with these requirements.

The safety precautions listed below represent warnings of certain dangers of which Motorola is aware. You, as the user of the product, should follow these warnings and all other safety precautions necessary for the safe operation of the equipment in your operating environment.

Ground the Instrument.

To minimize shock hazard, the equipment chassis and enclosure must be connected to an electrical ground. Both AC and DC versions of this equipment require a three-conductor power cable. A supplementary chassis ground is also provided. AC power cables must be plugged into an approved three-contact electrical outlet. The power jack and mating plug of the power cable must meet International Electrotechnical Commission (IEC) safety standards.

Do Not Operate in an Explosive Atmosphere.

Do not operate the equipment in the presence of flammable gases or fumes. Operation of any electrical equipment in such an environment constitutes a definite safety hazard.

Keep Away From Live Circuits.

Operating personnel must not remove equipment covers. Only Factory Authorized Service Personnel or other qualified maintenance personnel may remove equipment covers for internal subassembly or component replacement or any internal adjustment. Do not replace components with power cable connected. Under certain conditions, dangerous voltages may exist even with the power cable removed. To avoid injuries, always disconnect power and discharge circuits before touching them.

Do Not Service or Adjust Alone.

Do not attempt internal service or adjustment unless another person capable of rendering first aid and resuscitation is present.

Use Caution When Exposing or Handling CRTs.

Breakage of a Cathode-Ray Tube (CRT) causes a high-velocity scattering of glass fragments (implosion). To prevent CRT implosion, avoid rough handling or jarring of the equipment. CRTs should be handled only by qualified maintenance personnel using approved safety mask and gloves.

Do Not Substitute Parts or Modify Equipment.

Because of the danger of introducing additional hazards, do not install substitute parts or perform any unauthorized modification of the equipment. Contact your local Motorola representative for service and repair to ensure that safety features are maintained.

Dangerous Procedure Warnings.

Warnings, such as the example below, precede potentially dangerous procedures throughout this manual. Instructions contained in the warnings must be followed. You should also employ all other safety precautions which you deem necessary for the operation of the equipment in your operating environment.



Dangerous voltages, capable of causing death, are present in this equipment. Use extreme caution when handling, testing, and adjusting.



Regulatory Notices

Changes or modifications not expressly approved by Motorola Computer Group could void the user's authority to operate the equipment.

Use only shielded cables when connecting peripherals to assure that appropriate radio frequency emissions compliance is maintained.

FCC (U.S.)

Both Class A (commercial) and Class B (residential) digital devices have the following Federal Communications Commission (FCC) wording on the regulatory label:

This device complies with Part 15 of the FCC Rules.

Operation is subject to the following two conditions: (1) this device may not cause harmful interference, and (2) this device must accept any interference received, including interference that may cause undesired operation.

In addition, Class B equipment will also have an FCC ID number displayed such as: FCC ID: LNT600ADT. To determine the classification of your equipment, examine the FCC labels, which are readily visible on the exterior of the cabinets (usually on the back or bottom). If all labels have Class B ratings, the system is Class B. Any Class A label makes the system Class A.

For FCC Class A

NOTE: This equipment has been tested and found to comply with the limits for a Class A digital device, pursuant to part 15 of the FCC Rules. These limits are designed to provide reasonable protection against harmful interference when the equipment is operated in a commercial environment. This equipment generates, uses, and can radiate radio frequency energy and if not installed and used in accordance with the instruction manual, may cause harmful interference to radio communications. Operation of this equipment in a residential

area is likely to cause harmful interference, in which case the user will be required to correct the interference at his own expense.

Industry Canada

The classification of your system for Industry Canada can be determined by examining the regulatory labels, which are readily visible on the exterior of the cabinets (usually on the back or bottom). If all labels have Class B ratings, the system is Class B. Any Class A label makes the system Class A. The following wording in English or French or both, indicates the Classification.

This Class A digital apparatus meets all requirements of the Canadian Interference-Causing Equipment Regulations.

Cet appareil numérique de la classe * respecte toutes les exigences du Règlement sur le matériel brouilleur du Canada.

CE Notice (European Community)

Marking a system with the “**CE**” symbol indicates compliance of that Motorola system to the EMC and Low Voltage directives of the European Community. A system with the CE marking meets or exceeds the following technical standards:

EN 55022 “Limits and methods of measurement of radio interference characteristics of information technology equipment.”

EN 50082-1 “Electromagnetic compatibility - Generic immunity standard Part 1: Residential, commercial, and light industry.”

IEC 801-2 “Electromagnetic compatibility for industrial process measurement and control equipment Part 2: Electrostatic discharge requirements.”

IEC 801-3 “Electromagnetic compatibility for industrial process measurement and control equipment Part 3: Radiated electromagnetic field requirements.”

IEC 801-4 “Electromagnetic compatibility for industrial process measurement and control equipment Part 4: Electrical fast transient/burst requirements.”

EN 60950 “Safety of information technology equipment, including electrical business equipment.”

In accordance with European Community directives, a “Declaration of Conformity” has been made and is on file at Motorola, Inc. – Computer Group, 27 Market Street, Maidenhead, United Kingdom, SL6 8AE.

In addition to the above standards, this system has also met the requirements of the following European standards:

EN 60555-2 “Disturbances in supply systems caused by household appliances and similar electrical equipment Part 2: Harmonics.”

EN 60555-3 “Disturbances in supply systems caused by household appliances and similar electrical equipment Part 3: Voltage fluctuations.”

Contents

CHAPTER 1 General Information

- Overview 1-1
- Features 1-1
- General Description 1-2
 - Chassis Description and Specifications 1-3
 - Power Supply Description and Specifications 1-4
 - Power Supply Limit Considerations 1-5
 - VME Bus Backplane Description and Specifications 1-5
- Safety and Regulatory Compliance 1-6
- General Precautions 1-7
- Operating Environment 1-7
- Chassis Cooling Considerations 1-8
- Hardware Preparation 1-9
- Related Documentation 1-10

CHAPTER 2 Chassis Mount Options

- Overview 2-1
- Chassis Installation Instructions 2-1
 - Benchtop Operation 2-1
 - Install the Desktop Cover Kit 2-2
 - Rack Mounting Option 2-4

CHAPTER 3 Operating Procedures

- Overview 3-1
- Controls and Indicators 3-1
- Power Control Procedure 3-2

CHAPTER 4 12-Slot VMEbus Backplane

- Overview 4-1
- Physical Description 4-1
- Backplane Power 4-1
 - Backplane Bus Connectors 4-2

VME64x Bus Interface Signal Termination	4-2
Backplane Preparation	4-3
Install the Daisy-Chain Jumpers	4-5
Pin Assignments	4-6
Power Monitor Connection	4-6
Live Insertion	4-7

CHAPTER 5 Removal and Replacement Procedures

Overview	5-1
Following ESD and Safety Procedures	5-1
Power Supply	5-2
Removal	5-2
Replacement	5-4
Disk and Tape Drive	5-6
Removal	5-6
Replacement	5-7
VME64x Bus Backplane	5-9
Removal	5-9
Replacement	5-11
Cooling Fan	5-12
Removal	5-12
Optional Air Filter Kit	5-14
Replacement	5-14

CHAPTER 6 Support Information

Introduction	6-1
Drawings/Wiring Diagram	6-1
Parts Lists	6-2

List of Figures

Figure 2-1. Cover Kit	2-3
Figure 4-1. 12-Slot Backplane Connectors and Headers Rear View	4-4
Figure 4-2. Backplane Daisy-Chain Jumper Wiring	4-8
Figure 5-1. Power Supply Removal/Replacement	5-4
Figure 5-2. Disk/Tape Drive Removal	5-7
Figure 5-3. Backplane Mounting (Card File Removed)	5-10
Figure 5-4. Cooling Fan Removal/Replacement	5-13
Figure 6-1. MVME956AC Chassis Assembly, 1 of 2.....	6-5
Figure 6-2. MVME956AC Chassis Assembly, 2 of 2.....	6-6
Figure 6-3. MVME956AC Wiring Diagram.....	6-7

List of Tables

Table 1-1. MVME956AC Chassis Specifications	1-4
Table 1-2. 12-Slot VME Bus Backplane Specifications	1-5
Table 1-3. Hardware Preparation Items	1-9
Table 4-1. Power Monitor Connection	4-6
Table 4-2. Live Insertion Connections	4-7
Table 6-1. MVME956AC Chassis Parts List	6-2
Table 6-2. MVME956AC-AC Major Assemblies.....	6-4

Overview

This manual provides general information, hardware preparation, installation instructions, removal and replacement procedures for major assemblies, operational information, parts lists, and diagrams for the MVME956AC 12-slot chassis. Throughout the remainder of this manual, this enclosure may be referred to as the MVME956AC, or simply as the chassis.

Features

The features of the MVME956AC chassis include:

- ❑ VME board injector features in front card cage
- ❑ Board slot keying
- ❑ Internationally approved 550 watt power factor corrected, wide ranging power supply
- ❑ 12-slot, 64-bit, VME64X-compatible backplane with +5Vdc, +12Vdc and -12Vdc power supplied
- ❑ Optional SCSI drive kits
- ❑ Electrostatic Discharge (ESD) hardening and Electromagnetic Interference (EMI) shielding
- ❑ Forced air cooling for power supply, mass storage modules, and VME modules
- ❑ Rear mounted card cage for 17 transition modules, connected by cables to rear P2 connectors or P2 paddle boards
- ❑ Lab benchtop or rack-mount operation

Features of the 12-slot VME bus backplane include:

- ❑ Compatibility with standard VME (3-row) modules
- ❑ Compatibility with standard VME64x modules requiring only +5Vdc, +12Vdc, and -12Vdc backplane power and no direct P2 transition module connections
- ❑ 12 VME slots (24 sockets, 160-pin IEC 1076-4_xxx, 2.54mm receptacle connectors for VME modules)
- ❑ 64-bit address and data (P1 and P2)
- ❑ VME64x bus and VME64X bus termination
- ❑ 35 additional signal ground return
- ❑ 46 additional user-defined I/O pins
- ❑ Geographical addressing
- ❑ +5Vdc, +12Vdc, and -12Vdc power supplied
- ❑ +3.3Vdc power is not supplied

General Description

The MVME956AC chassis is designed for OEMs and other technical professionals who wish to integrate individual VME module board-level products into a complete, compact, self-contained microcomputer system, including disk and/or tape drive units. This packaging design helps to best meet your specific performance and installation requirements. Various options to permit the convenient assembly of systems for custom installation and/or application are possible.

The major assemblies of the MVME956AC are:

- ❑ Chassis with card cage, power supply, backplane, power switch, and cooling fans. Operates on 115/220 Vac input power.
- ❑ AC power supply, 550W, 115/230 Vac input (+5 Vdc, +12 Vdc, and -12 Vdc). Includes cooling fan and housing with cables.

- VME module backplane. Contains 12 connectors for P1 and P2 of VME bus.

The basic chassis, power supply, and backplane are described in this manual. The optional disk drives, tape drives, and controllers are described in their respective manuals or reference sheets. Refer to the [Related Documentation](#) on page 1-10 for additional information.

Chassis Description and Specifications

The MVME956AC chassis is designed for industry-standard 3-row VME modules and VME64X modules not requiring +3.3Vdc backplane power. The chassis accommodates five additional peripheral drive and houses a VME module card cage with 12 VME bus slots. The front panel opening accommodates the five 5-1/4-inch, half-height SCSI peripheral devices. The control for the chassis is an ON/OFF power switch. When the switch is in the OFF position, power to the modules is removed but the primary side of the power supply remains energized. Power is supplied by an internal 550 watt wide-ranging power supply, which is mounted vertically toward the rear of the chassis. There is provision for 17 rear panel-mounted 80 mm interface modules.

Three DC-powered fans provide forced air cooling for the power supply, mass storage enclosure, and VME modules. Convection cooling is used for the rear-mounted modules.

The rear of the chassis supports standard double-high Eurocard panels and 80 mm modules such as MVME7XX series modules. [Table 1-1](#) lists the specifications for the MVME956AC chassis and power supply. [Table 1-3](#) lists the specifications for the 12-slot backplane. Specifications for the SCSI drives and VME modules used in the MVME956AC chassis are given in their respective manuals or reference sheets. Refer to [Related Documentation](#) on page 1-10 for information.

Table 1-1. MVME956AC Chassis Specifications

Characteristics	Specifications
Dimensions	
Width	
(with front flange)	19.00 inches (482.6 mm)
(without front flange)	17.20 inches (436.8 mm)
Depth	19.02 inches (483.1 mm)
Height	12.22 inches (310.4 mm)
Weight	32 pounds (15 kg)
Input voltage	90-132/180-264 Vac
Input frequency	47 to 63 Hz
Input power	90-132 Vac or 180-264 Vac
Output voltages	+5 Vdc @ 80A
	+12 Vdc @ 10A (16A peak)
	-12 Vdc @ 10A
Output power	550 Watts (max.)
Temperature (NOTE)	
Operating	0 degrees C to 40 degrees C
Storage	-40 degrees C to +60 degrees C
Relative humidity (NOTE)	20% to 80% (noncondensing)

Note Temperature and humidity limits are primarily determined by the type of tape and disk media that you expect to install.

Power Supply Description and Specifications

DC power is supplied by a 550-watt wide-ranging power supply. It is mounted in a fan-cooled air duct assembly and installed in the rear of the chassis behind the disk drives. The cooling fan runs constantly when the power supply is plugged in.

Power Supply Limit Considerations

The MVME956AC chassis is supplied with a 550-watt, 3-output switching power supply. The power supply is capable of higher output currents than the interconnection to the backplane. As designed, the enclosure +5 Vdc output is rated at 60 amperes, the +12 Vdc output at 10 amperes (16 peak), and the -12 Vdc output at 10 amperes.



Caution

The current rating for each individual output must not be exceeded, and the total power supply output power must not exceed 550 watts. When calculating the 5-volt current, remember to include the backplane termination resistors.

The system integrator must ensure that the installed peripheral devices and VME module set do not exceed the power supply rating.

VME Bus Backplane Description and Specifications

The MVME956AC chassis contains one 12-slot, full 64-bit VME bus backplane mounted to the left of the peripheral device area. The backplane can accommodate up to 12 VME modules. It uses all signal and power lines for VME bus connectors P1 and P2.

Table 1-2. 12-Slot VME Bus Backplane Specifications

Characteristics	Specifications
Power consumption (without device modules)	5W (1.0 A max @ +5V), required by active termination
Connectors Device sockets	24 sockets: 160-pin IEC1076-4_xxx 2.54mm connectors Socket spacing (center-to-center): 0.8 inch

For more detailed information on the VME bus backplane, refer to the *VME Extensions Standard, VITA 1.1-199X*, which can be found at <http://www.vita.com>.

Safety and Regulatory Compliance

All systems integrated by Motorola meet the standards claimed for those systems with regard to electromagnetic interference (EMI), radio frequency interference (RFI), and overall safety. It is possible, however, to install circuit boards and drives in the MVME956AC enclosure that produce a system not in compliance with the applicable emission limits.

Note It is the integrator's responsibility to design a payload that meets the desired standards.

When Motorola integrates a payload into the MVME956AC enclosure, it is often necessary to make changes to the payload in order for the system to pass RFI standards. The following is a list of conditions that in general must be met in order to achieve compliance with RFI standards:

- ❑ At a minimum, the chassis must be connected to earth ground through the safety ground wire in the power cord to meet safety and other requirements.
- ❑ All external I/O cables should be high-quality shielded types with metal shell connectors.
- ❑ Connectors on VME modules should be metal shell types, connected to earth ground. This is accomplished through the conductive panels in contact with the chassis rails.
- ❑ All VME modules should have conductive panels to ensure a good RF ground with the conductive chassis rails.
- ❑ Blank panels with EMI gaskets should be installed over all unused chassis slots to ensure there are no RF leaks in the chassis.

- ❑ The VME module front panel screws should be properly tightened for good grounding.

For minimum RF emissions, it is essential that the foregoing conditions be implemented. Failure to do so could compromise the RFI compliance of the system.

This product, as configured and shipped by Motorola, has been designed and tested for compliance with the following RFI standards and product safety regulations:

- ❑ Electromagnetic Compatibility: FCC class A; European CE Class A
- ❑ Safety: UL 1950; CSA C22.2/950; VDE EN 60 950; IEC 950

It is the customer's responsibility to verify compliance if the customer makes changes or additions to the "as-shipped" configuration.

General Precautions

- ❑ Ensure that the air space above and below the chassis is not blocked, and that the inlet screens and optional air filter are clean.
- ❑ The air inlet temperature must not exceed 40 degrees Celsius. If the MVME956AC is installed in a rack with other chassis, be sure that each chassis in the rack is provided with its own supply of fresh cooling air. Do not use air heated by one chassis to "cool" another chassis.
- ❑ All unused VME module slots must be covered to prevent cooling air and/or RF emissions from escaping from the chassis.
- ❑ The chassis should be used only in a clean environment such as an office or lab.

Operating Environment

When using tape and disk drive units in the MVME956AC chassis observe the following:

- ❑ This equipment is intended for use in a relatively clean environment (office or lab). In some industrial environments, you may need to provide additional protection against airborne contaminants in order to assure reliable operation of the floppy disk and magnetic tape drives and media.
- ❑ This equipment is intended for use in an enclosure consisting of the front bezel together with the Motorola top panel and side panels or equivalent. Operating this equipment without a front bezel may compromise compliance with RFI and/or product safety regulations. It may expose the operator to electrical and mechanical hazards.

Chassis Cooling Considerations



Caution

The system integrator must ensure that all modules used in the system are properly cooled. The following information will help you to determine whether the cooling is adequate.

The MVME956AC chassis is designed for an input air temperature below 40 degrees Celsius. Three DC-powered fans provide forced-air cooling for the power supply, mass storage enclosure, and VME modules. The direction of air flow is: in at the bottom of the chassis, past the power supply and VME modules, and out the top of the chassis. The 24-volt fans deliver 81 CFM at zero inches of water. An air filter is optional.

The fans provide airflow sufficient for most VME modules, but some high-density, high-power modules may require more cooling than this enclosure provides. When integrating VME modules that are known to be difficult to cool, testing is advisable to confirm that such modules are properly cooled.

No forced air cooling is provided for the rear-mounted modules. The rear-mounted modules are typically transition modules with few active components, and cooling is generally not required.

Hardware Preparation

There are a number of items to check or tasks to perform before you apply power to the chassis. These items include, but are not limited to, the items summarized in the following table.

Table 1-3. Hardware Preparation Items

Item	Location of Instructions
VME bus backplane jumpers	<i>Chapter 4</i> of this manual
Install modules	User's manual(s) for the respective module(s)
Install cables (as required)	MVME956AC installation instructions, also other user's manual(s) as applicable
Chassis rack mounting	<i>Chapter 2</i> of this manual
Jumper options on modules used in this chassis (as required)	User's manual(s) for the respective module(s)
<i>For peripheral drives:</i> Select jumper options on disk drive(s)	System manual, kit instructions

Related Documentation

Document Title	Motorola Publication Number
MVME946 Desktop Cover Kit Installation Instructions	MVME946CVR
MVME946 Rack Mount Kit Installation Instructions	MVME946RKMT
MVME946 Air Filter Kit Installation Instructions	MVME946AFO
System Manual Module Set	68-SYSMODULE

The following VMEbus publications are available from the sources indicated.

ANSI/IEEE Std 1014-1987 Versatile Backplane Bus:
The Institute of Electrical and Electronics Engineers, Inc.,
345 East 47th Street, New York, NY 10017, USA.
<http://standards.ieee.org/>

VME64 Extensions Specification, VITA 1.1-199X.
VMEbus International Trade Association,
<http://www.vita.com>

Vita 1.x Live Insertion for VME64x Requirements Standard, VMEbus International Trade Association, <http://www.vita.com>

Overview

This chapter includes the installation instructions for the MVME956AC chassis. Instructions on the installation of replacement assemblies are in [Chapter 6](#).



Dangerous voltages, capable of causing death are present in this equipment. Use extreme caution when handling, testing and adjusting.



Unless otherwise instructed, perform all hardware preparation and/or installation with power disconnected. Installing or removing hardware items such as modules and cables while power is applied may damage the equipment.

Chassis Installation Instructions

The MVME956AC chassis can be configured for either rack mounting or for lab benchtop use. This section describes the steps necessary to install the optional desktop cover on the chassis for lab benchtop use or to rackmount your unit.

Benchtop Operation

The MVME956AC chassis can be placed on a standard table or desk for operation as a lab benchtop unit. For this configuration, the chassis must be equipped with the Motorola side panels, top panel, and disk drive cover. To prepare the MVME956AC for operation as a lab benchtop unit, follow these steps.

Install the Desktop Cover Kit

1. The top and side panels are attached with ball stud pop-on, pop-off catches. If the ball studs are not already installed on the chassis, unpack the studs and thread them into place in the holes provided in the top and sides of the chassis.
2. Install the side panels by positioning the ball stud catches over the ball studs and pressing firmly inward until the catches engage.
3. Install the top panel by positioning the ball stud catches over the ball studs and pressing downward until the catches engage.

Be sure the chassis is resting on a strong, level table or desk, in a clean environment, with plenty of air space above and around the chassis. Refer to [Chassis Cooling Considerations](#) on page 1-8.

If you desire to have an MVME956AC chassis with top and side panels after previously having purchased a chassis without them, order the cover kit (MVME946CVR) referenced in *Related Documentation* on page 1-10.

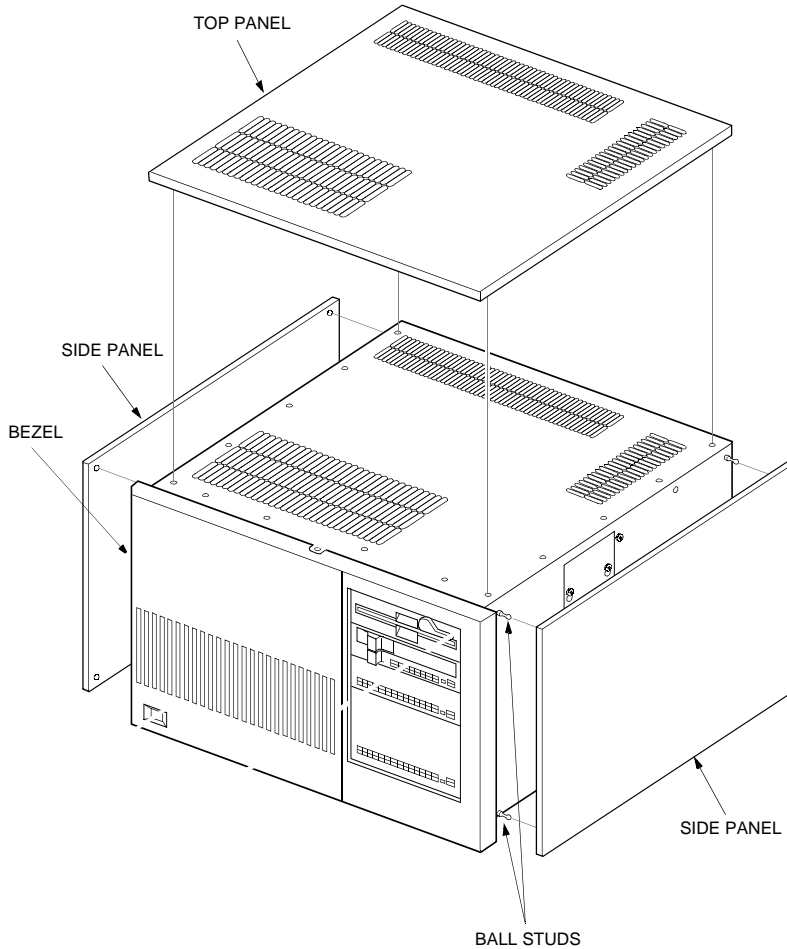

11819.00 9797

Figure 2-1. Cover Kit

Rack Mounting Option

The MVME956AC can be mounted, along with other equipment, in a standard 19-inch RETMA (or equivalent) rack. If the chassis is equipped with the benchtop cover kit, you must first remove it.

Cover Kit Removal

1. The top and side panels are attached with ball stud pop-on, pop-off catches. Remove the top panel by grasping the panel at the edges and lifting it straight up from the chassis.
2. Remove the side panels by firmly grasping each panel and pulling it straight out from the chassis.
3. Remove the ball studs from the top and sides of the chassis.
4. Remove the disk drive cover from the front opening.

To rack mount the MVME956AC unit, you must use the optional slide mounting kit, MVME946RKMT. Be sure to observe and follow the special cooling requirements explained in [Chapter 1](#).

To rack-mount an MVME956AC chassis, follow the procedure below.

1. Install the two chassis slide sections as shown in using the binder-head screws that came in the kit. The right and left sections are identical.
2. Determine where you will mount the chassis in the rack and how much space is required for mounting. Install the rack slide rails in the equipment rack using the binder-head screws and barnuts supplied. The chassis can now be installed in the rack.

Note: The rack slide rails (18-5/8 inches) must coincide with that of the chassis slide rails.

3. Align the chassis slide sections with the two rack-mounted slide sections.
4. While depressing the loc/stop buttons on the chassis slide sections, slide the chassis into the rack. Adjust the slide mounting hardware until the chassis slides in and out smoothly.

5. Secure the chassis using the rear mounting bracket supplied.
6. Reinstall the front bezel by aligning the pop-on/off catches on the back of the bezel with the ball studs on the front panel of the chassis. Press firmly into place.
7. Reconnect the power cable and power-on the system.



Implementation of this procedure may invalidate product safety (e.g., UL, CSA, etc.) and RFI regulatory compliance (FCC, VDE).

Overview

This chapter provides a description of the controls, indicators, and operating procedures for the MVME956AC chassis.

System operation using this chassis is completely dependent on your choice of hardware and software. Therefore, the only operation discussed here is a suggested basic power on/power off procedure.

Controls and Indicators

The MVME956AC chassis contains one control (switch). The switch has an indicator (LED) that is powered by the +5 Vdc output from the power supply. Some of the individual modules used in the chassis may also contain controls and/or indicators. This manual describes only those that are part of the chassis. For a description of other related controls and indicators, refer to the documentation that came with your module(s).

The control provided for the MVME956AC chassis is an AC power ON/OFF switch. With the switch in the OFF position, power to the modules is removed but the primary side of the power supply remains energized. This switch is located at the lower left front corner of the chassis and provides a convenient means of powering the chassis up and down.

Power Control Procedure

A suggested power-on procedure for the chassis is as follows:

1. Ensure that all modules and cabling are properly configured and installed. Also check that all required external cabling (to peripherals) is correctly installed.
2. Plug in the AC line cord (at the rear of the chassis) and connect the cord to an AC power source.
3. Set the power switch at the front of the chassis to (ON). The power supply cycles up and the cooling fans immediately come on.
4. Power up any peripheral equipment interfaced to the chassis that has its own power on/off switch.

A suggested power-off sequence for the chassis is as follows:

Note Ensure that proper software shutdown procedures have been executed before you continue.

1. Power down any peripheral equipment interfaced to the chassis that has its own power on/off switch.
2. Set the power switch to OFF. The power supply cycles down, and the cooling fans stop running. For the AC chassis only, the power supply fan will continue to run.

Overview

This chapter provides a physical and electrical description of the 12-slot VME bus backplane used in the MVME956AC chassis. Refer to [Chapter 1](#) for features and specifications of the backplane. Refer to [Chapter 6](#) for removal and replacement procedures.

Physical Description

The backplane was designed to accommodate VME modules and disk drive units. It accommodates up to 12 double-high user VME modules containing both P1 and P2 connectors. The backplane is fully assembled with connectors and terminators. It contains:

- ❑ 12 connectors on the top row to receive connector P1 of the VME modules
- ❑ 12 connectors on the bottom row to receive VME module expansion connector P2

Backplane Power

VME modules that plug into the backplane require voltages of +5 Vdc, +12 Vdc, and -12 Vdc for operation. The MVME956AC chassis contains a power supply and wiring that provide these voltages to the backplane.

The power connectors characteristics and the number and arrangement of their pins are summarized in Figure 4-1 on page 4-4.

Backplane Bus Connectors

All rows of J101 through J112 (Z, A, B, C, D) are interconnected across all 12 slots, which provides the required signals for A24/D16 operation.

The center row (B) of J201 through J212 is interconnected across all 12 slots, which provides the required signals for extended operation (A32/D32).

Rows A and C of J201 through J212 are not interconnected, but are available for I/O functions or expansion bus operation.

VME64x Bus Interface Signal Termination

Signal lines are terminated with active termination. For further information on bus termination and VME64x bus backplane specifications, refer to the *VME64 Extensions Specification*, VITA 1.1-199x.

Backplane Preparation

The chassis is shipped from the factory with the backplane fully equipped with sockets (VME64X bus connectors), power connectors, and bus terminator resistor networks. No special preparation or preassembly is required prior to use.

You must configure the VME64X bus daisy-chain jumpers on the rear (wire side) of the backplane. Refer to *VITA 1.x Live Insertion for VME64x* requirements standard for more electrical detail and information on daisy-chain jumpering.

Note Backplane daisy-chain jumpers normally are shipped with the chassis. If necessary, additional jumpers can be ordered from Motorola.

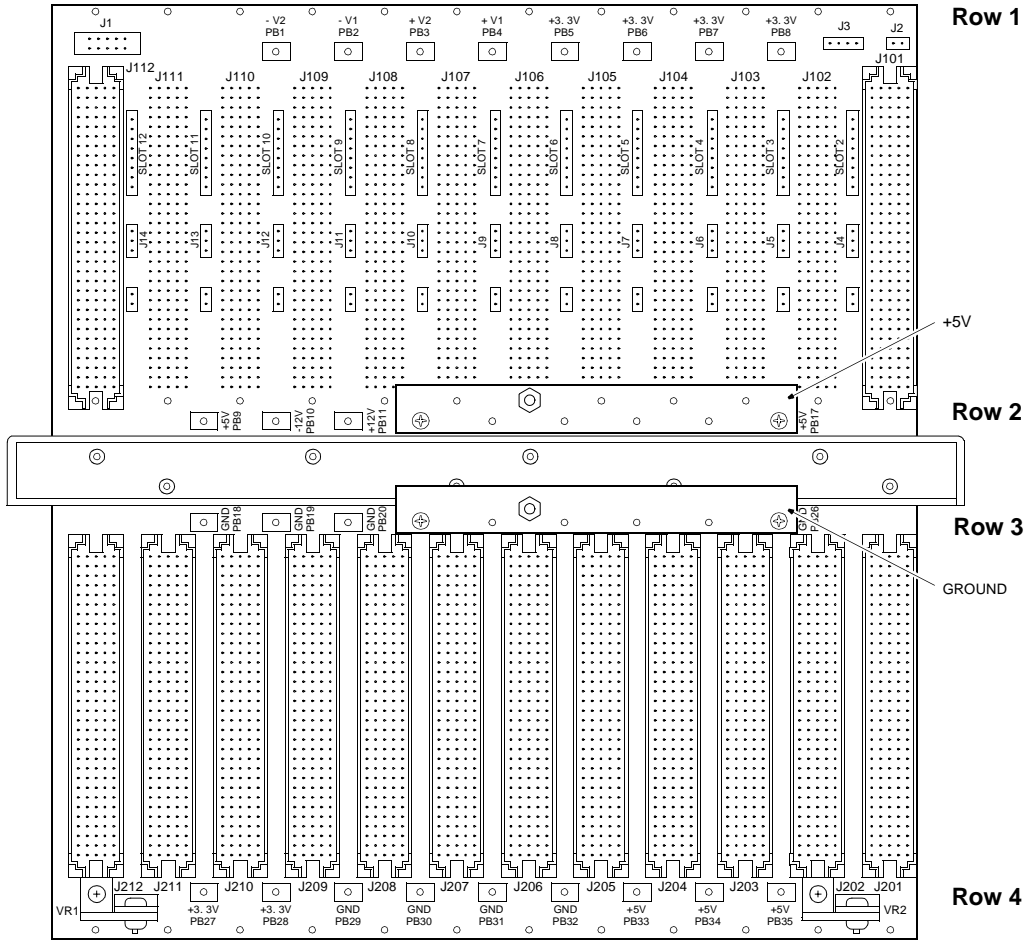

11864.00 9709

**Figure 4-1. 12-Slot Backplane Connectors and Headers
Rear View**

Install the Daisy-Chain Jumpers

All daisy-chain lines of the VME64x bus can be separately bypassed with removable shorting jumpers on every connector socket. Shorting the input to the output of the daisy-chain signals is required if the daisy-chains are in use, and if a VME64x module design does not provide for the propagation of the daisy-chain.

For instance, if a backplane slot contains a device module designed for daisy-chain signal propagation, no jumpers are required on the jumper pins for that slot. However, all empty slots, and slots containing modules without this capability, must have daisy-chain jumpers installed to provide propagation of these signals.

Daisy-chain bypass jumper areas are provided on the rear side of the backplane. For an illustration of the backplane daisy-chain jumper wiring, see Figure 4-2 on page 4-8.

The following procedure is suggested for installing the jumpers:

1. Attach an ESD strap to your wrist. Attach the other end of the ESD strap to the chassis as a ground. The ESD strap must be secured to your wrist and to ground throughout the procedure.
2. Perform an operating system shutdown. Turn the AC or DC power off and remove the AC cord or DC power lines from the system.
3. At the rear of the backplane, select the row(s) of header pins that require jumpers. Any backplane slot that will not be occupied by a VME64x module requires jumpers on the rear backplane pins to propagate the Bus Grant (BG) and Interrupt Acknowledge (IACK) signals to the next VME64x module slot. See Figure 4-1 on page 4-4 and Table 4-2 on page 4-7.

For example: If a VME64x module is used in all slots except slots J103 and J106, jumpers must be installed on the BG and IACK pins associated with those slots. (The pins that must be jumpered are the ones located immediately to the left of the module slot, J4 through J14, depending on the slot, when viewed from the rear of the backplane.) In this case, the following pairs of header pins would require jumpers:

- Row of pins, left side of slot J103 - BG0, BG1, ...
- Row of pins, left side of slot J106 - BG0, BG1, ...

Carefully align the jumper(s) on the correct pair of pins to be jumpered and gently push until the top of the jumper is flush with the top of the pins.

4. Continue in this fashion, placing jumpers on all pairs of pins for each backplane slot that will not be occupied by a VME64x module.

Pin Assignments

Power Monitor Connection

Connectors J1 and J3 provide for the power monitor signals ACFAIL, SYSFAIL and SYSRESET. They have the following pinouts.

Table 4-1. Power Monitor Connection

Pin Assignment for J1 Connector		Pin Assignment for J3 Connector	
J1-1	GND	J3-1	ACFAIL
J1-2	NC	J3-2	SYSFAIL
J1-3	SYSRST	J3-3	SYSRST
J1-4	NC	J3-4	GND
J1-5	SYSFAIL		
J1-6	NC		
J1-7	ACFAIL		
J1-8	NC		
J1-9	+5V		
J1-10	NC		

For the location of these connectors, see Figure 4-1 on page 4-4.

Live Insertion

Sockets J4-J14 allow the daisy-chained bus grant arbitration and interrupt priority resolution processes to continue unaffected during live insertion or removal. These sockets, in conjunction with the headers for bus grant signal jumpers and the headers for IACK signal jumpers can be used with a user-supplied daisy-chain switch module. This switch module incorporates the backplane daisy-chain bypass circuits.

Table 4-2. Live Insertion Connections

Sockets J4 through J14	
Pin 1	+5V
Pin 2	LI/O
Pin 3	GND
NOTE: All jumper pins in slots that use the live insertion must be removed before installing a user-supplied daisy chain switch module.	

Header J2 can be used to monitor IACK signal on both pin 1 and pin 2.

For further information, refer to the *VITA 1.x Live Insertion for VME64x* requirements standard.

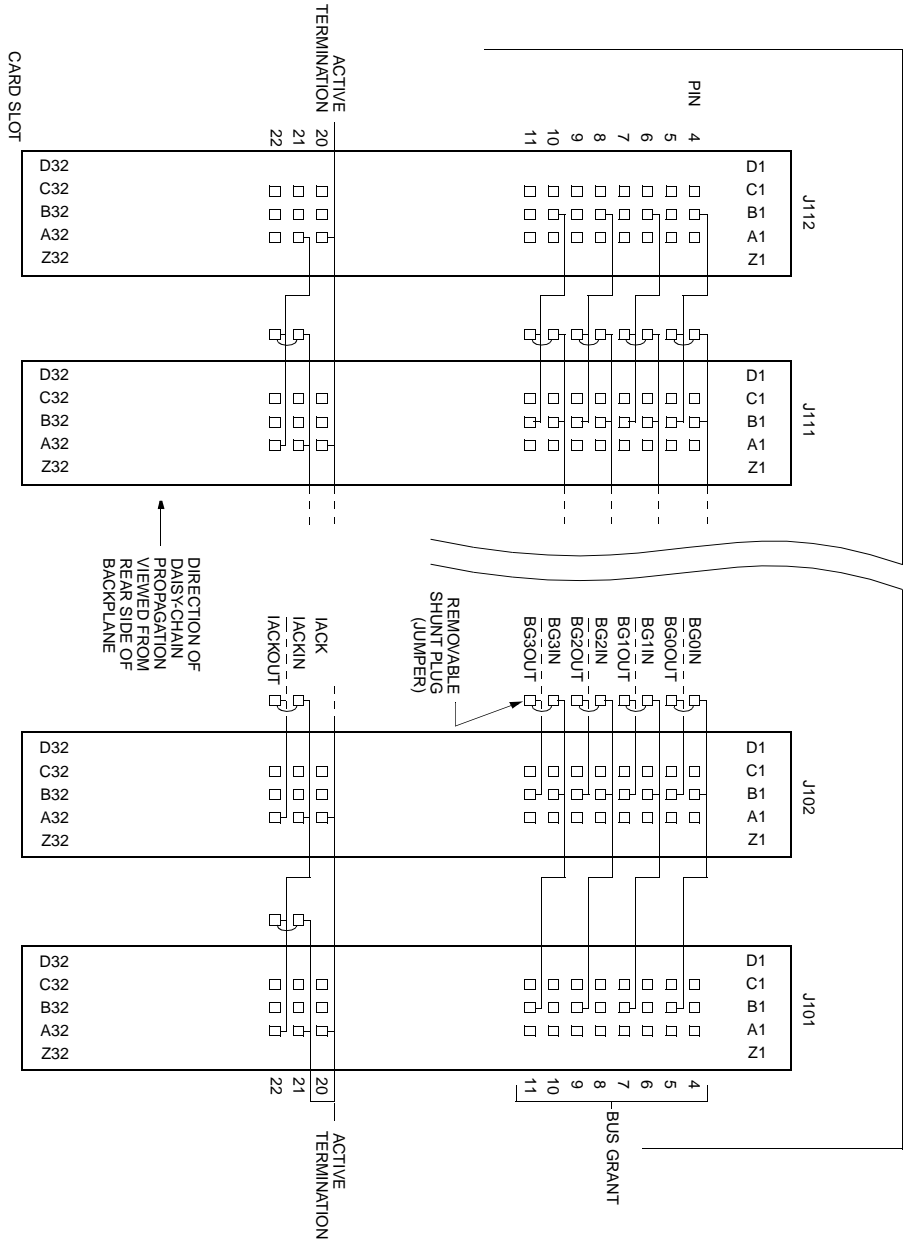

Figure 4-2. Backplane Daisy-Chain Jumper Wiring

2114 9710

Removal and Replacement Procedures

5

Overview

This chapter provides recommended procedures for the removal and replacement of MVME956AC chassis major assemblies. For identification and location of the assemblies and parts mentioned in these procedures, refer to the drawings and parts lists in [Chapter 7](#).

The removal/replacement procedures are organized and presented in the following order:

- ❑ *Power Supply*
- ❑ *Disk and Tape Drive*
- ❑ *VME64x Bus Backplane*
- ❑ *Cooling Fan(s)*
- ❑ *Optional Air Filter Kit*

Following ESD and Safety Procedures

Use ESD

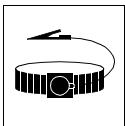

Wrist Strap

Motorola strongly recommends that you use an antistatic wrist strap and a conductive foam pad when installing or upgrading the system. Electronic components, such as disk drives, computer boards, and memory modules, can be extremely sensitive to ESD. After removing the component from the system or its protective wrapper, place the component flat on a grounded, static-free surface, and in the case of a board, component-side up. Do not slide the component over any surface.

If an ESD station is not available, you can avoid damage resulting from ESD by wearing an antistatic wrist strap (available at electronics stores) that is attached to an unpainted metal part of the system chassis.



Turn the system's power off before you perform these procedures. Failure to turn the power off before opening the system can result in personal injury or equipment damage. Hazardous voltage, current, and energy levels are present in this product. Power switch terminals can have hazardous voltages present even when the power switch is off. Do not operate the system with the cover removed. Always replace the cover before turning on the system.

5

Prior to performing any of the following installation or removal procedures, follow these steps.

1. Attach an ESD strap to your wrist. Attach the other end of the ESD strap to the chassis as a ground. The ESD strap must be secured to your wrist and to ground throughout the procedure.
2. Perform an operating system shutdown. Turn the AC or DC power off and remove the AC cord or DC power lines from the system.

Power Supply

The suggested procedure for the removal and replacement of the power supply assembly is as follows:



Removal of the power supply provides access to high voltages. Ensure the power cord is removed from the power supply. Allow one minute for the capacitors in the power supply to discharge.

Removal

1. Turn the power OFF to all equipment and disconnect the power cable from the AC power source.
2. If the MVME956AC chassis is rack mounted, slide it from the rack, or if it is a lab benchtop unit, remove the top panel and right side panel.

3. Remove the screws holding the top cover to the chassis and remove the top cover.
4. Remove the power supply mounting screw from the right side of the chassis. Remove the additional screws from the back of the chassis.
5. Disconnect the cable assemblies from the power supply or from the backplane, if access to the power supply connections is difficult.
6. Disconnect the +5V, +12V, -12V, and RTN wires from the connections on the power supply.
7. Slide the power supply assembly vertically up and out of the chassis.

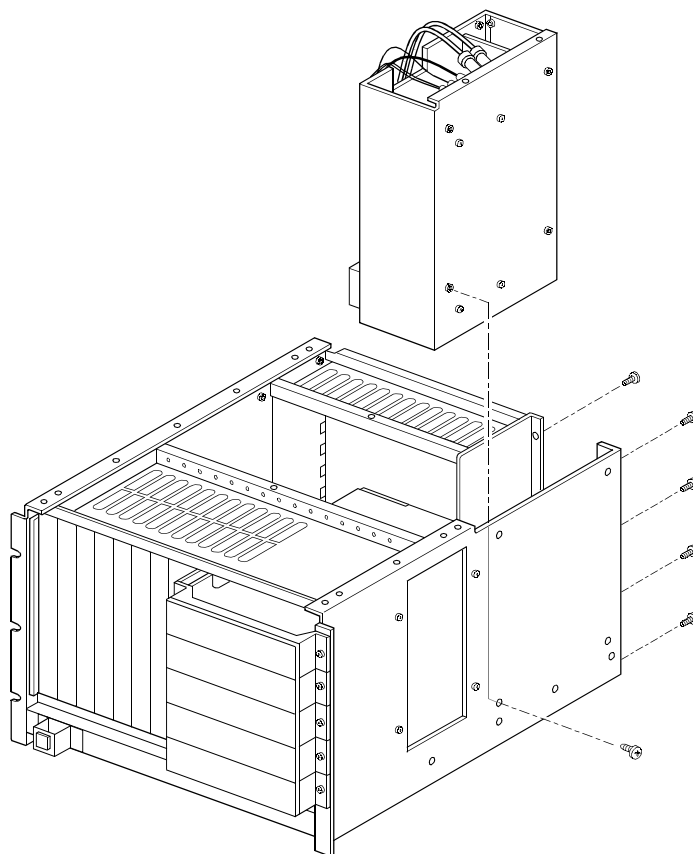

Figure 5-1. Power Supply Removal/Replacement

Replacement

To replace the power supply assembly or to install an exchanged assembly, follow these procedures.

1. Slide the power supply assembly vertically back into the chassis.
2. Reconnect the +5V, +12V, -12V, and RTN wires disconnected in [Step 6](#).

3. Reconnect the cable assemblies removed in [Step 5](#) above to the power supply or backplane.
4. Reinstall the power supply mounting screw from the side of the chassis. Reinstall the screws you removed from the back of the chassis in [Step 4](#) above.
5. Replace the chassis' top cover with the screws removed in [Step 3](#) above.
6. Slide the MVME956AC chassis back into its rack mounting or reinstall the top and side panel on your lab benchtop unit.

Disk and Tape Drive

To remove and replace disk and/or tape drives, follow these procedures.

Removal

5

1. Turn the power OFF to all equipment and disconnect the power cable from the AC power source.
2. Slide the MVME956AC chassis out from its rack mounting remove the top panel and the side panel nearest the drives.
3. Remove the front bezel.
4. Loosen the screws that engage the keyhole slots in the right side access cover. Lift the cover up and off the screws.
5. Remove the screws on either side of the drive and partially pull the drive out of the chassis. Disconnect the data and power cables. Remove the drive from the chassis.
6. Remove the screws connecting the drive mount bracket to the drive.
Note: If this is a permanent removal, ensure that the remaining drive identifications are correct and the terminating resistor is properly installed.
7. If the drive is to be immediately replaced, go on to the replacement procedure at this point.
8. Position the side access cover on the screws to engage the keyhole slots properly. The washers must be on the outside of the cover.
9. When the screws have properly engaged the keyhole slots, slide the cover down and tighten the screws.
10. Replace the front bezel.
11. Slide the MVME956AC chassis back into its rack mounting or replace the side panel and the top panel to your lab benchtop unit.

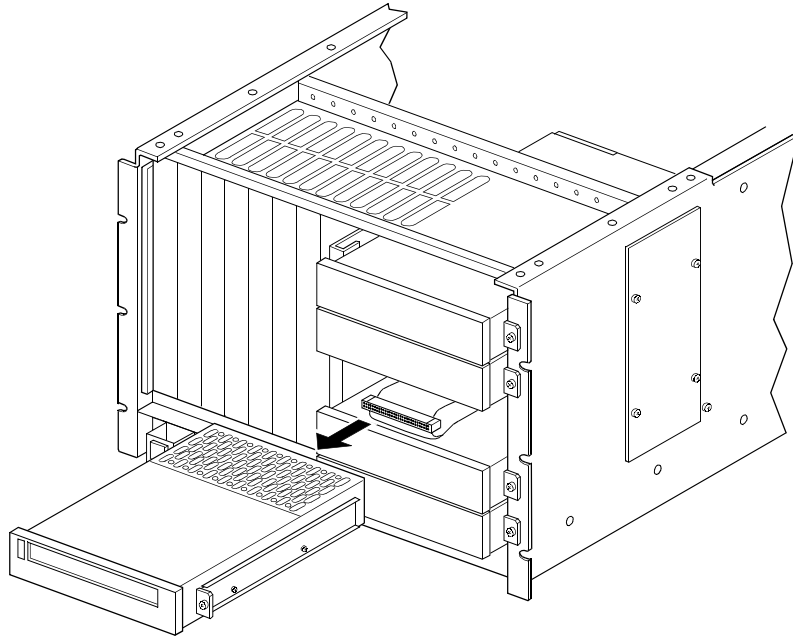

11823.00 9708

Figure 5-2. Disk/Tape Drive Removal

Replacement

1. Follow the replacement procedure in the installation instructions that came with your drive.
Note: Use the short (1/4 inch long) screws to attach the brackets to the drive. The longer screws may damage the drives. Ensure that all drives are properly identified and that the terminating resistor is installed or removed as applicable.
2. Reconnect the power and data cables.
3. Position the side access cover on the screws to engage the keyhole slots properly. The washers must be on the outside of the cover.
4. When the screws have properly engaged the keyhole slots, slide the cover down and tighten the screws.

5. Replace the front bezel.
6. Slide the MVME956AC chassis back into its rack mounting or replace the side panel and the top panel to your lab benchtop unit.

To reset the jumper addresses, refer to the installation instructions that came with your drive.

VME64x Bus Backplane

To remove or replace the backplane used in the MVME956AC chassis, follow these procedures.

Removal

1. Turn the power OFF to all equipment and disconnect the power cable from the AC power source.
2. Remove all external cabling connected to modules installed in the chassis. Then remove all modules installed in the chassis.
3. Slide the MVME956AC chassis out from its rack mounting or remove the top panel of your lab benchtop unit.
4. Remove the screws holding the top cover to the chassis and lift off the top cover.
5. For better access to the backplane, you may remove the rear card file subassembly from the rear of the chassis by removing the screws on the left and right sides of the card file.
6. Remove all internal cables connected at the rear of the backplane.
7. Remove all power wires from the rear of the backplane.
Note: Mark the wire locations carefully so they can be correctly reinstalled. Incorrect connection of these wires can cause damage to the equipment.
8. Disconnect the bus bar's ground and +5V by removing the screws that attach it to the backplane.
9. Disconnect the stiffener bar from the chassis by removing the two screws located on the left side of the chassis. Then, remove the two screws on the right side of the chassis by accessing through the drive cable access panel.
10. Loosen and remove the two rows of screws that secure the backplane to the chassis frame members. Then remove the backplane.

11. Now remove the stiffener from the backplane by removing the screws from the front of the backplane. Note that the adhesive associated with the insulating tape on the stiffener may make the removal of the stiffener from the backplane somewhat difficult. Take caution to prevent damage to the backplane when prying the stiffener off.

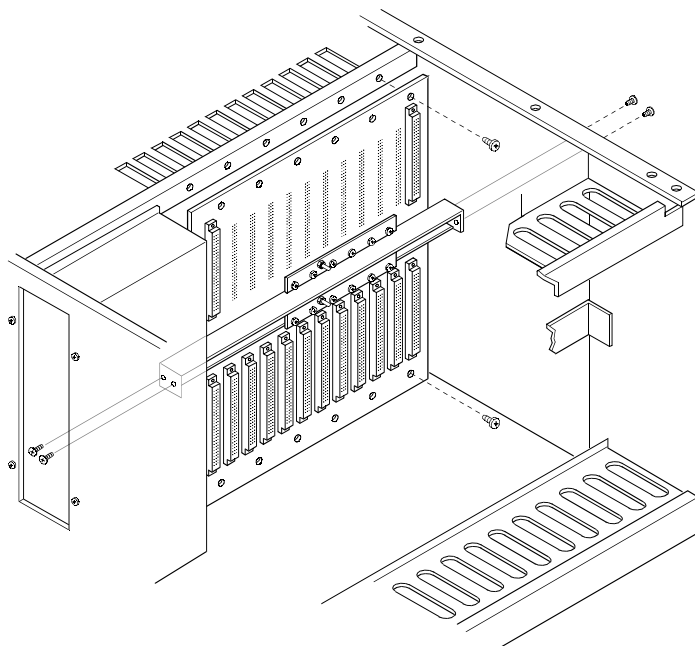

11869.00 9710

Figure 5-3. Backplane Mounting (Card File Removed)

Replacement

1. Attach the stiffener to the backplane with the screws removed in [Step 11](#) above.
2. Position the backplane with the J1 and J2 connectors toward the front of the chassis.
3. Attach the backplane to the chassis frame members with the screws removed in [Step 10](#) above.
4. Attach the ends of the stiffener to the chassis using the screws removed in [Step 9](#) above.
5. Attach the ground bus bar to the backplane with the screws removed in [Step 8](#) above.
6. Connect all power wires removed in [Step 7](#) above.
7. Connect all cables removed in [Step 6](#) above to the rear of the backplane.
8. Slide the card file back into position and attach with the screws removed in [Step 5](#).
9. Install the modules removed in [Step 2](#) above.
10. Replace the top cover of the chassis with the screws removed in [Step 4](#) above.
11. Slide the MVME956AC chassis back into its rack mounting or reinstall the top panel on your lab benchtop unit.
12. Connect all external cabling removed in [Step 2](#) above.

Cooling Fan

To remove or replace one or more of the chassis cooling fans, follow these procedures.

Removal

5

1. Turn the power OFF to all equipment and disconnect the power cable from the AC power source.
2. Slide the MVME956AC chassis out from its rack mounting or remove the top panel and side panels of your lab benchtop unit.
3. Remove the front bezel.
Note: Refer to [Figure 7-1 on page 7-5](#) and [Table 7-2 on page 7-4](#) for parts identification and location.
4. At the left and right side of the chassis, remove the three screws along each side of the base which hold the hinged fan tray and air filter door in the chassis.
5. If the MVME956AC is not mounted in a rack, lay the unit on one side.
6. Remove the screws that keep the fan tray and air filter door secured.
7. Swing the fan tray and air filter door open.
8. Depending on the fan you are replacing, unplug the appropriate fan wire connector from its mating connector.
See the wiring diagram in [Figure 7-3 on page 7-7](#).
9. Using a nut driver, remove the nuts and screws that secure the fan to the tray.
10. Remove the fan.

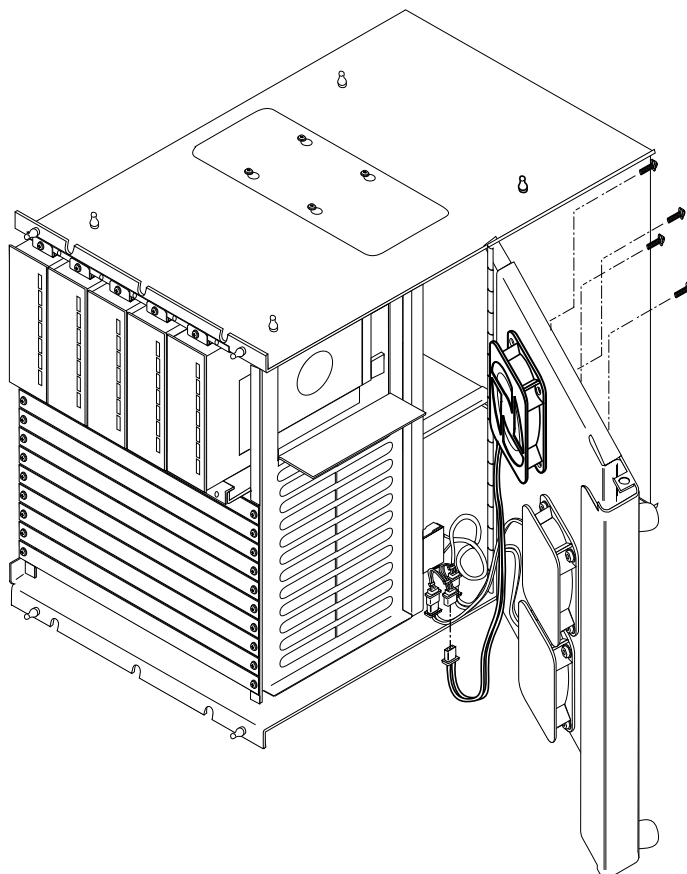

Figure 5-4. Cooling Fan Removal/Replacement

Optional Air Filter Kit

If you are using the optional air filter (MVME946AFO) and wish to replace it, refer to *Related Documentation* on page 1-10 for information on the Air Filter Kit.

Replacement

5

1. Attach the new fan to the fan tray with the screws removed in [Step 9](#) above.
2. Plug the appropriate fan wire connector into its mating connector.
3. Rotate the fan tray and air filter door back into place and secure them with the screws removed in [Step 4](#) and [Step 6](#) of the removal procedure. Set the unit upright if it is not mounted in a rack.
4. Reinstall the front bezel.
5. Slide the MVME956AC chassis back into its rack mounting or reinstall the top panel and side panels on your lab benchtop unit.

Introduction

This chapter provides parts lists, wiring diagram, and assembly drawings for the MVME956AC chassis. For information concerning drawings and parts lists for power supplies and mass storage units used in this chassis, refer to their respective manuals or reference sheets.

Drawings/Wiring Diagram

Chassis assembly drawings for the MVME956AC chassis are provided in this chapter. A chassis wiring diagram is included as part of the main assembly drawing of the chassis. These drawings represent the latest design at the time of printing. Occasionally, minor component changes are made at the factory. Therefore, when replacing defective components or parts, always use the same value as the defective part, even though the diagram or drawing may indicate a different value or type.

Parts Lists

Parts lists are provided for the MVME956 chassis major assemblies. This list reflects the latest issue of hardware at the time of printing. The parts list for the main chassis is provided below. The parts list for the major assemblies is in [Table 6-2 on page 6-4](#). The main assembly parts location is illustrated in [Figure 6-1 on page 6-5](#)

Table 6-1. MVME956AC Chassis Parts List

COMPONENT	DESCRIPTION
27-W5328C01x	Chassis assembly
01-W1631B02x	Bezel assembly, 956
01-W2030E01x	AC power supply
01-W2287D01x	Assy fan, 24V Cholla+
01NW9804E44	Backplane assy, 1 2-slot, VME ext
07-W5215C01x	Access cover, left side
07-W5224C01x	Access cover, right side
07-W5225C01x	Card cage
07-W5329C01x	Cover, 956
07-W6858B01x	SCSI cable cover
07-W5331C01x	Stiffener, 956 motherboard
07-W6907B01x	Fan guard, Cholla+
07NW9502A96	Guard, 20x20mm, SW
30-W2285D02x	Power cable harness assembly
30-W2297D02x	DC harness,+2V MNFR.
30-W2295D03x	Cable assembly, switch/enable, AC unit
30-W2296D03x	Harness assembly, DC harness/enable
31-W5330C01x	Bus bar, 956 motherboard
33-W6414B01x	Voltage warning label
33-W4120C01x	Label enclosure, US
33-W6862B02x	Label enclosure, universal
64-W4211B01x	BDL, 1 wide

Table 6-1. MVME956AC Chassis Parts List (Continued)

COMPONENT	DESCRIPTION
64-W4727C01x	Front panel blanks
13-W6275B01x	Brk, mld dr flr
42NW9401A80	Mount, push cable tie
42NW9401B28	Tywrap, nylon,L3-7/8,B3/4
42NW9401B33	Retainer, tywrap, self-adhesive
42NW9401B35	Tywrap, nylon, L7-3/8,B1-7/8
75NW9402A32	Foot, round
29NW9805A83	Lug, quick connect, .250 w/blde
29NW9805B17	Jumper, insulated shorting
29NW9805B34	Terminator, .187"X.02" quick connect
29NW9805B38	Lug, quick connect, .187" w/blde
04NW9005A60	Flat washer, FLT, #10
03NW9004B48	Captive Screw, m2.5
03SW990F608	Sem, Phillips
03SW990F012	Sem, Phillips panhead, 10-32X3/4"
03SW990F604	Sem, Phillips panhead, 6-32X1/4"
03SW990F606	Sem, Phillips panhead, 6-32X3/8"
03SW990F626	Sem, Phillips, 6-32X1-5/8"
03SW990F806	Sem, Phillips panhead, 8-32X3/8"
03SW991F604	Screw, Phillips flathead, 6-32X1/4"
03SW993D212	Screw, Phfil, M2.5X.45X 12SCYI
02SW995E005	Nut, hex 10-32
02SW999E002	Nut, hex 6-32

Table 6-2. MVME956AC-AC Major Assemblies

Model	Part Number	Common Name	Description
MVME956-AC		Chassis assy	Chassis with card cage, power supply, backplane, power switch, and cooling fans. Operates on 115/220 Vac input power.
---	01-W2030E01X	Power supply	Power supply, 550W, 115/230 Vac input (+5 Vdc, +12 Vdc, and -12 Vdc). Includes cooling fan and housing with cables.
---	01-NW9804E44	Backplane	VMEmodule backplane. Contains 12 connectors for P1 and P2 of VME bus.

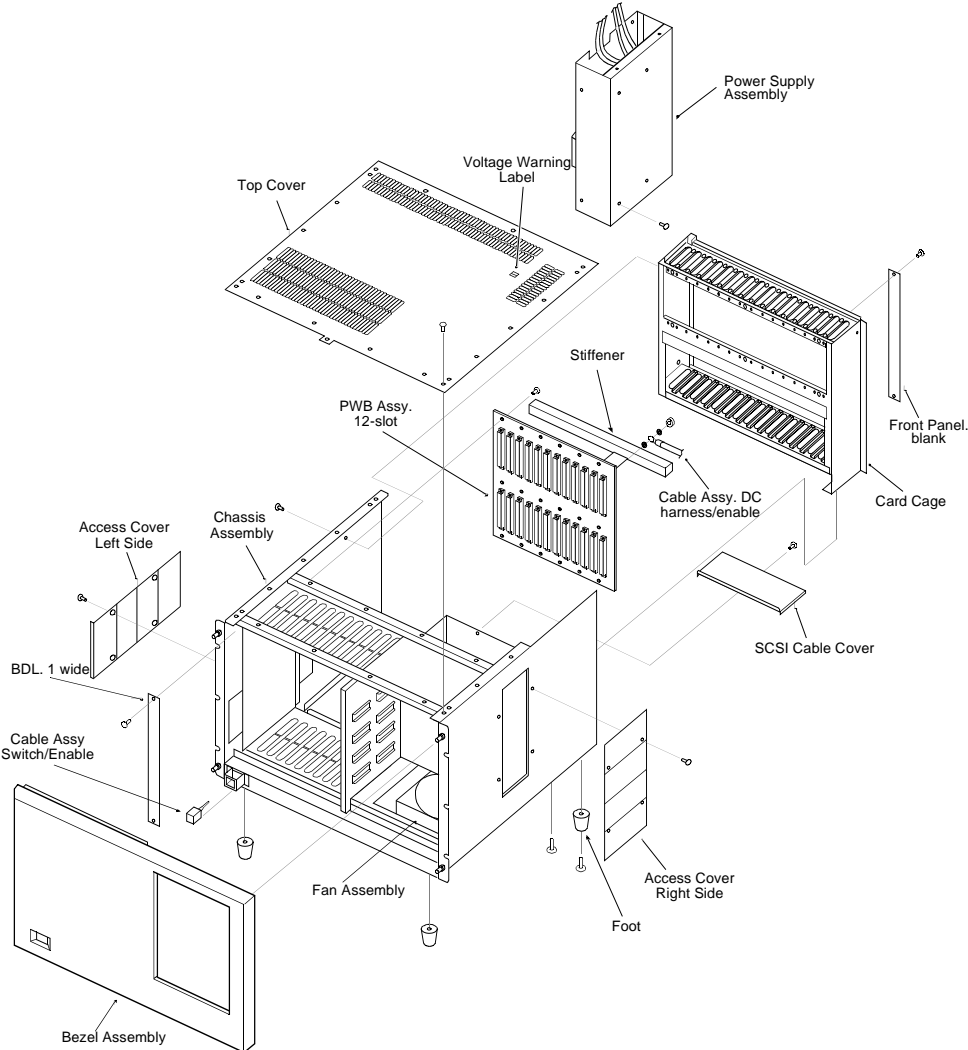

11877.00 9710

Figure 6-1. MVME956AC Chassis Assembly, 1 of 2

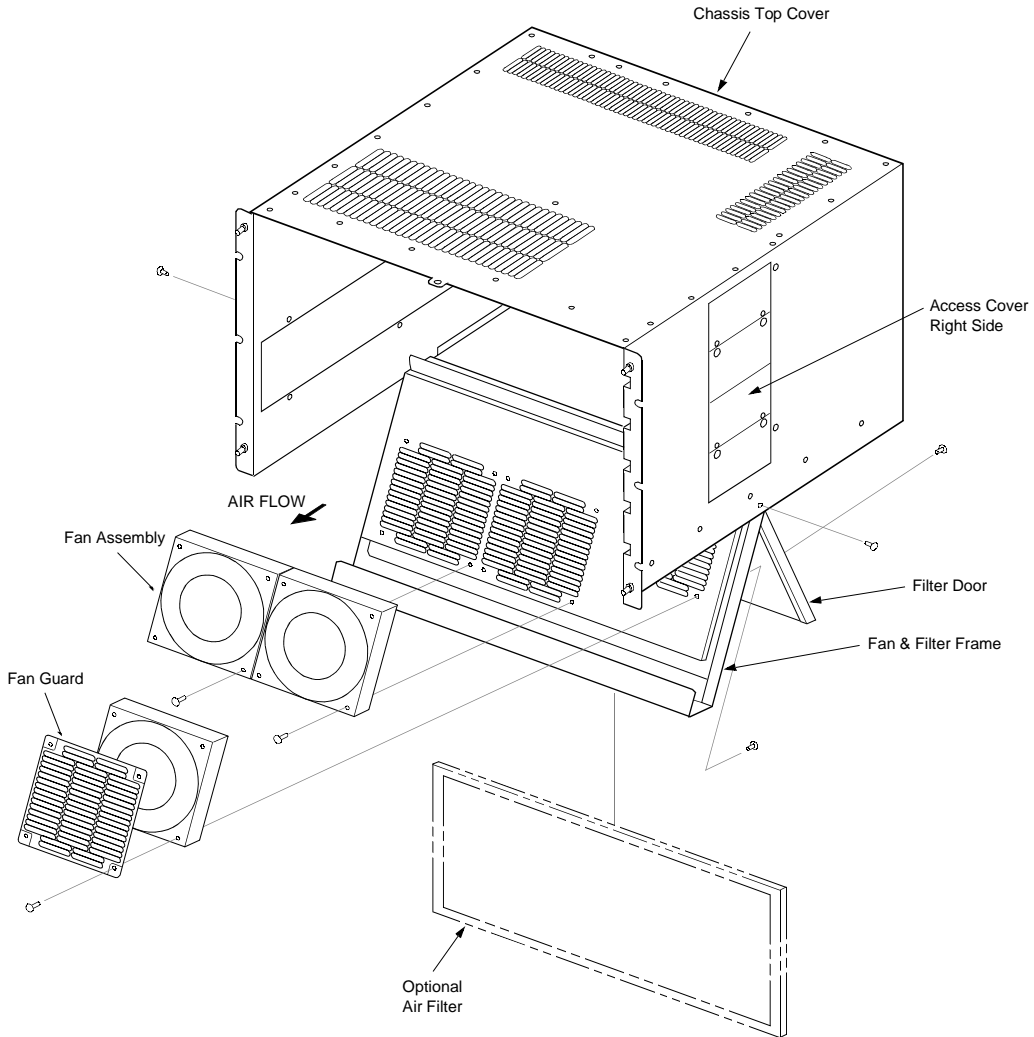

11876.00 9710

Figure 6-2. MVME956AC Chassis Assembly, 2 of 2

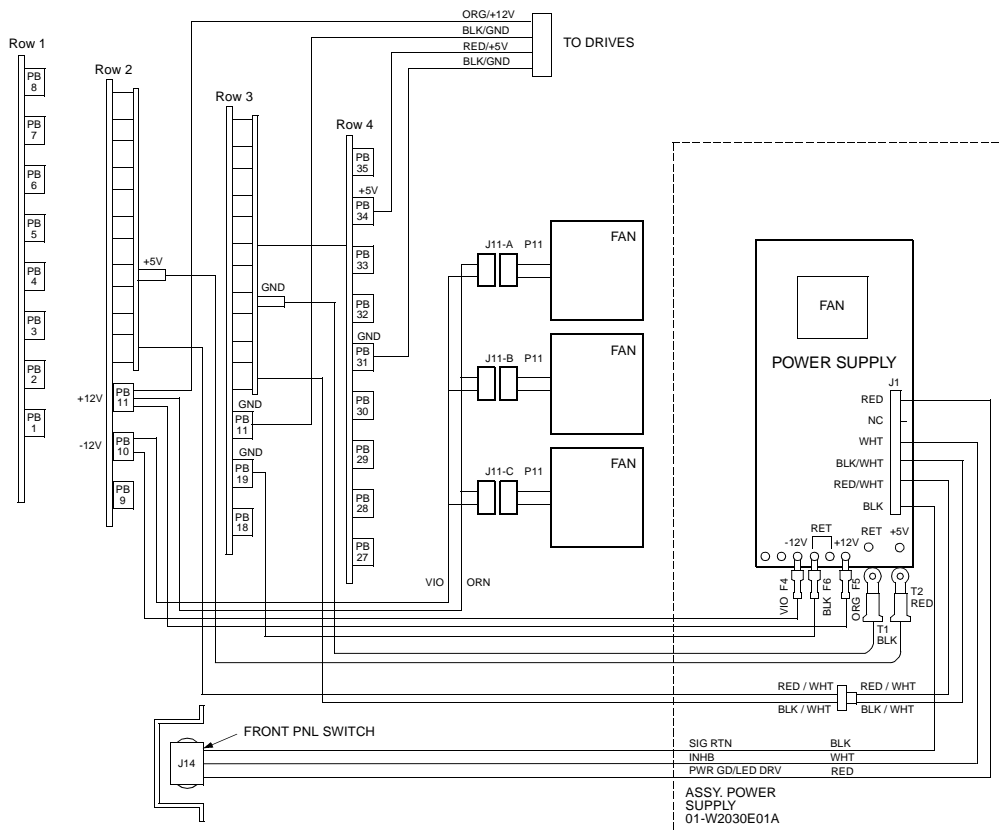

2115 9710

Figure 6-3. MVME956AC Wiring Diagram

A

- A24/D16 operation [4-2](#)
- A32/D32 operation [4-2](#)
- ACFAIL [4-6](#)
- air cooling [1-3](#), [1-8](#)
- air filter door [5-14](#)
- air filter, optional [1-8](#)
- assemblies
 - backplane [1-2](#)
 - chassis [1-2](#)
 - power supply [1-2](#)
- assembly drawings [6-1](#)

B

- backplane
 - bus connectors [4-2](#)
 - physical description [4-1](#)
 - power output [4-1](#)
 - preparation [4-3](#)
- backplane description [1-5](#)
- backplane power [1-3](#)
- benchtop cover kit, ordering [2-3](#)
- BG pins [4-5](#)
- bus termination [4-2](#)

C

- chassis
 - components [1-2](#)
 - controls and indicators [3-1](#)
 - cooling [1-8](#)
 - documentation [1-10](#)
 - features [1-1](#)
 - installing [2-1](#)

- major assemblies [1-2](#)
- operating environment [1-8](#)
- power supply [1-3](#)
- regulatories [1-6](#)
- setup precautions [1-7](#)
- specifications [1-3](#)
- use and purpose [1-2](#)
- chassis assemblies, removal and replacement
 - [5-1](#)
- control switch, location [3-1](#)
- cooling requirements [1-8](#)
- cover kit, installation [2-2](#)
- cover kit, removal [2-4](#)

D

- d SYSRES [4-6](#)
- daisy-chain
 - configure jumpers [4-3](#)
 - install jumpers [4-5](#)
 - jumper bypass [4-5](#)
 - jumper wiring [4-8](#)
 - jumpering [4-5](#)
 - shorting the input to output [4-5](#)
 - signal propagation [4-5](#)
 - switch module [4-7](#)
- drive brackets, install [5-7](#)
- drives, optional [1-3](#)

E

- ESD procedures [5-1](#)
- Eurocard panels [1-3](#)
- expansion bus [4-2](#)
- extended operation [4-2](#)

F

front panel, description 1-3

H

hardware issue 6-2

hardware preparation 1-9

I

I/O functions, backplane connectors 4-2

IACK pins 4-5

install drive brackets 5-7

installation instructions 2-1

L

live insertion 4-7

M

manual overview 1-1

module support 1-3

mounting, benchtop 2-1

mounting, rack 2-4

O

operating environment 1-8

ordering jumpers 4-3

overview of manual 1-1

P

parts list

 chassis assemblies 6-2

 for subassemblies 6-1

 main assembly 6-2

pin assignments 4-6

power monitor connections 4-6

power supply

 description 1-2, 1-4

 limits 1-4

preparation of backplane 4-3

procedures

 benchtop operation 2-1

 install jumpers 4-5

 power control 3-2

 power-off 3-2

 power-on 3-1

 safety 5-1

 to rack mount 2-4

publications, related 1-10

R

rack mount, slide mounting kit 2-4

remove/replace AC power supply 5-2 to 5-5

remove/replace backplane 5-9 to 5-11

remove/replace cooling fan 5-12 to 5-14

remove/replace drives 5-6 to 5-8

RF emissions, precautions 1-7

RFI compliance 1-7, 1-8

RFI standard 1-6

S

safety procedures 5-1

SCSI drive specifications 1-3

setting up the chassis 1-7

signal line termination 4-2

SYSFAI 4-6

system operation 3-1

system shutdown 5-2

T

temperature requirements 1-7

terminating signal lines 4-2

U

using tape and disk drive units 1-7

V

VME modules and backplane 4-1

VME64x requirements standard 4-3

VMEbus backplane

 description 1-5

VMEmodule specifications 1-3

voltage requirements, backplane 4-1

W

wiring diagram 6-1

Free Manuals Download Website

<http://myh66.com>

<http://usermanuals.us>

<http://www.somanuals.com>

<http://www.4manuals.cc>

<http://www.manual-lib.com>

<http://www.404manual.com>

<http://www.luxmanual.com>

<http://aubethermostatmanual.com>

Golf course search by state

<http://golfingnear.com>

Email search by domain

<http://emailbydomain.com>

Auto manuals search

<http://auto.somanuals.com>

TV manuals search

<http://tv.somanuals.com>