

OWNER'S MANUAL

Sunbeam

Microwave Oven

SMW1100

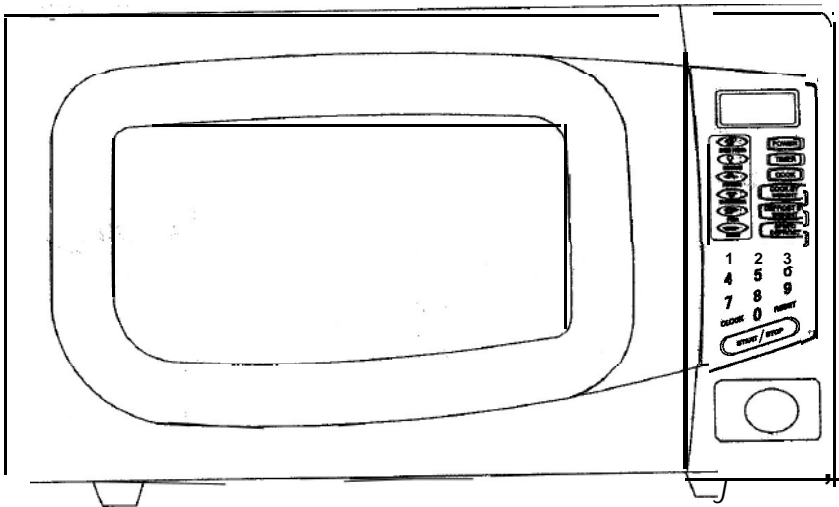

1. Read these instructions carefully before installing and operating the oven. Keep them for future reference.
2. Record in the space below the SERIAL NO. found on the nameplate on your oven and retain this information for future reference.

SERIAL NO.:

3. Complete and return the attached card.

PRECAUTIONS TO 'AVOID POSSIBLE EXPOSURE TO EXCESSIVE MICROWAVE ENERGY

- (a) **Do not attempt** to operate this oven with the door open since open door-operation can result in harmful exposure to microwave energy. It is important not to defeat or tamper with the safety interlocks.
- (b) **Do not place** any object between the oven front face and the door or allow soil or cleaner residue to accumulate on sealing surfaces.
- (c) **Do not operate** the oven if it is damaged. It is particularly important that the oven door close properly and that there is no damage to the:
 1. **Door** (bent),
 2. **Hinges and latches** (broken or loosened),
 3. **Door seals and sealing surfaces.**
- (d) **The oven should not be adjusted or repaired by anyone except properly qualified service personnel.** Refer to the warranty card.

CONTENTS

PRECAUTIONS TO AVOID POSSIBLE EXPOSURE TO EXCESSIVE MICROWAVE ENERGY.	1
IMPORTANT SAFETY INSTRUCTIONS	2
GROUNDING INSTRUCTIONS	3
UTENSILS GUIDE	4
COOKING TECHNIQUES	6
BEFORE YOU CALL FOR SERVICE	7
SPECIFICATIONS	7
NAMES OF PARTS	7
CONTROL PANEL	a
OPERATING INSTRUCTIONS	a
ABOUT "QUICK COOK" SETTINGS	1 2
CLEANING AND CARE	1 2

IMPORTANT SAFETY INSTRUCTIONS

When using this electrical appliance, basic safety precautions should be followed, including the following:

WARNING - To reduce the risk of burns, electric shock, fire, injury to persons or exposure to excessive microwave energy:

1. Read all instructions before using the appliance.

2. Read and follow the specific

"PRECAUTIONS TO AVOID POSSIBLE EXPOSURE TO EXCESSIVE MICROWAVE ENERGY" on page 1.

3. Select a level surface that provides enough open space for the intake and/or outlet vents. A minimum clearance of 3 inches is required between the oven and any adjacent wall. One side must be open. Leave a minimum clearance of 3 inches above the oven. Do not cover or block any openings on the appliance. Do not remove feet from the bottom of the oven. This appliance must be grounded. Connect it only to properly grounded outlet. See "GROUNDING INSTRUCTIONS" on page 3.

4. ~~Some~~ products such as whole eggs ~~sealed~~ containers, and closed glass jars may explode-and should not be

heated in this oven.

5. Use this appliance only for its intended use as described in this manual. Do not use corrosive chemicals or vapors in this appliance. This type of oven is specifically designed to heat, cook or dry food. It is not designed for industrial or laboratory use.
6. As with any appliance, close supervision is necessary when used by children.
7. To reduce the risk of fire in the oven cavity:
 - a. Do NOT overcook food. Carefully attend appliance if paper, plastic or other combustible materials are placed inside the oven to facilitate cooking.
 - b. Remove wire twist-ties from paper or plastic bags before placing bag in oven.
 - c. **If materials inside the oven should ignite, keep oven door closed, turn oven off, and disconnect the power cord or shut off power at the fuse or circuit breaker panel.**
 - d. Do NOT use the cavity for storage purposes. Do not leave paper products, cooking utensils or food in the cavity when not in use.

SAVE THESE INSTRUCTIONS

8. Do NOT operate with an empty oven, as damage could result to the oven or its components.
9. Microwaves do not penetrate and use of metal (including paper twist ties) can cause sparking and possible fire.
10. Microwave heating of beverage can result in delayed eruptive boiling, therefore care has to be taken when handling the container.
11. Do NOT deep fry food in the microwave. It is difficult to control the fat which could cause a fire hazard.
12. Pierce foods with heavy skins such as potatoes, whole squash, apples and chestnuts before cooking.
13. The contents of feeding bottles and baby jars should be stirred or shaken and the temperature should be checked' before serving in order to avoid burns.
14. Do NOT tamper with or make any adjustments or repairs to the door, control panel housing, safety interlocks, switches or any other parts of the oven. Do NOT remove outer panel from the oven. Repairs should only be done by a qualified service person.
15. Do NOT operate the oven when empty. The microwave energy will reflect continuously throughout the oven if no food or water is present to absorb energy.
16. If a fire occurs in the oven, turn the oven off and LEAVE THE DOOR CLOSED. Disconnect the power cord.
17. Do NOT dry clothes, newspapers or other materials in the oven. They may catch on fire.
18. Do NOT use recycled paper products, as they may contain impurities which may cause sparks and/or fires when used.
19. Do NOT use newspaper or paper bags for cooking.
20. Do NOT hit or strike the control panel. Damage to the controls may occur.
21. POT HOLDERS may be needed when cooking. Heat is transferred from the hot food to the cooking container.
22. Do NOT store flammable materials next to, on top of, or in the oven. They can be a fire hazard.
23. Do NOT use the oven without the glass tray and roller ring in place.
24. Cooking utensils may become hot because of heat transferred from the heated food, Potholders may be needed to handle the utensil.
25. Do NOT store or use this appliance outdoors. Do not use this product near water, for example, near a kitchen sink, in a wet basement, or near a swimming pool.
26. Do NOT operate this appliance if it has a damaged cord or a plug, if it is not working properly or if it has been damaged or dropped.
27. Do NOT immerse cord or plug in water. Keep cord away from heated surface. Do not let cord hang over edge of table or counter.

SAVE THESE INSTRUCTIONS

28. Use only thermometers which are specifically designed for use in microwave ovens.
29. Do NOT operate any heating or cooking appliance beneath this appliance.
30. Be certain the glass tray and roller ring are in place when you operate the oven.

WARNING: It is hazardous for anyone other than a trained person to perform any service or repair operation which involves the removal of any cover which gives protection against exposure to , microwave energy.

GROUNDING INSTRUCTIONS

This appliance must be grounded. In the event of an electrical short circuit, grounding reduces risk of electric shock by providing an escape wire for the electric current.

WARNING: Improper use of the grounding plug can result in a risk of electric shock.

Electrical Requirements

The electrical requirements are a 120 volt 60 Hz, AC only, 20amp. It is recommended that a separate circuit serving only the oven be provided. The oven is equipped with a 3-prong grounding plug. It must be plugged into a wall receptacle that is properly installed and grounded. A short power-supply cord is provided to reduce risk of becoming entangled in or tripping over a long cord.

Extension Cord

If it is necessary to use an extension cord, use only a 3-wire extension cord that has a 3-prong grounding plug and a 3-slot receptacle that will accept the plug on the microwave oven.

- Notes:
1. If you have any questions about the grounding or electrical instructions, consult a qualified electrician or service person.
 2. Neither Sunbeam nor the dealer can accept any liability for damage to the oven or personal injury resulting from failure to observe the electrical connection procedures

Radio or TV Interference

Should there be any interference caused by the microwave oven to your radio or TV, check that the microwave oven is on a different circuit, relocate the radio or TV as far away from the oven as feasible or check position and signal of receiving antenna.

UTENSILS GUIDE

This section lists which utensils can be used in the microwave, which ones have limited use for short periods, and which ones should not be used in the microwave.

Recommended

- **Microwave browning dish** — Use to brown the exterior of small items such as steaks, chops, or pancakes. Follow the directions provided with your browning dish.
- **Microwavable plastic wrap** — Use to retain steam. Leave a small opening for some steam to escape and avoid placing it directly on the food.
- **Paper towels and napkins** — Use for short-term heating and covering; these absorb excess moisture and prevent spattering. Do not use recycled paper towels, which may contain metal and could ignite.
- **Glass and glass-ceramic bowls and dishes** — Use for heating or cooking.
- **Paper plates and cups** — Use for short-term heating at low temperatures. Do not use recycled paper, which may contain metal and could ignite.
- **Wax paper** — Use as a cover to prevent spattering.
- **Thermometers** Use only those labeled “Microwave Safe” and follow all directions. Check the food in several places. Conventional thermometers may be used on microwave food once the food has been removed from the oven.

Limited Use

- **Aluminum foil** — Use narrow strips of foil to prevent overcooking of exposed areas. Using too much foil can damage your oven, so be careful.
- **Ceramic, porcelain, and stoneware** -Use these if they are labeled “Microwave Safe”.
- **Plastic** — Use only if labeled “Microwave Safe”. Other plastics can melt.

Not Recommended

- **Glass jars and bottles** — Regular glass is too thin to be used in a microwave. It can shatter and cause damage and injury
- **Paper bags** — These are a fire hazard, except for popcorn bags that are designed for microwave use.
- ***Styrofoam plates and cups** -These can melt and leave an unhealthy residue on food.
- **Plastic storage and food containers** -Containers such as margarine tubs can melt in the microwave.

SAVE THESE INSTRUCTIONS

Download from www.Somanuals.com. All Manuals Search And Download.

- **Metal utensils** — These can damage your oven. Remove all metal before cooking.

Note: Should you wish to check if a dish is safe for microwaving, place the empty dish in the oven and microwave on HIGH for 30 seconds. A dish which becomes very hot should not be used.

COOKING TECHNIQUES

Your microwave makes cooking easier than conventional cooking, provided you keep these considerations in mind:

Stirring

Stir foods such as casseroles and vegetables while cooking to distribute heat evenly. Food at the outside of the dish absorbs more energy and heats more quickly, so stir from the outside to the center. The oven will turn off when you open the door to stir your food.

Arrangement

Arrange unevenly shaped foods, such as chicken pieces or chops, with the thicker, meatier parts toward the outside of the turntable where they receive more microwave energy. To prevent overcooking, place delicate areas, such as asparagus tips, toward the center of the turntable.

Turning

Turn foods over midway through cooking to expose all parts to microwave energy. This is especially important with large foods such as roasts.

Standing

Foods cooked in the microwave build up internal heat and continue to cook for a few minutes after heating stops. Let foods stand to complete cooking, especially foods such as cakes and whole vegetables. Roasts need this time to complete cooking in the center without overcooking the outer areas. All liquids, such as soup or hot chocolate, should be shaken or stirred when cooking is complete. Let liquids stand a moment before serving. When heating baby food, stir well upon removal and test the temperature before serving..

Adding moisture

Microwave energy is attracted to water molecules. Food that is uneven in moisture content should be covered or allowed to stand so that the heat disperses evenly. Add a small amount of water to dry food to help it cook.

SAVE THESE INSTRUCTIONS

..

BEFORE YOU CALL FOR SERVICE

If the oven fails to operate:

A) Check to ensure that the oven is plugged in securely. If it is not, remove the plug from the outlet, wait 10 seconds and plug it in again securely.

B) Check for a blown circuit fuse or a tripped main circuit breaker. If these 'seem to be operating properly, test the

outlet with another appliance,

C) Check to ensure that the control panel is programmed correctly and the timer is set

D) Check to ensure that the door is securely closed engaging the door safety lock system. Otherwise, the microwave energy will not flow into the oven.

IF NONE OF THE ABOVE RECTIFY THE SITUATION, THEN CONTACT A QUALIFIED TECHNICIAN. DO NOT TRY TO ADJUST OR REPAIR THE OVEN YOURSELF. REFER TO WARRANTY CARD.

SPECIFICATIONS

Power Consumption:

120V~60hZ, 1450W

output:

1 000W

Operation Frequency:

2450MHz

Outside Dimensions(H X W X D):

13x20x16 in.

Oven Cavity Dimensions(H X W X D):

8 3/4 X 13 3/4 x 13 3/4 in.

Oven Capacity:

1.0 cu.ft.

Cooking Uniformity:

Turntable System (Φ 12 3/8")

Net Weight:

Approx. 37.4 lbs.

PART NAMES

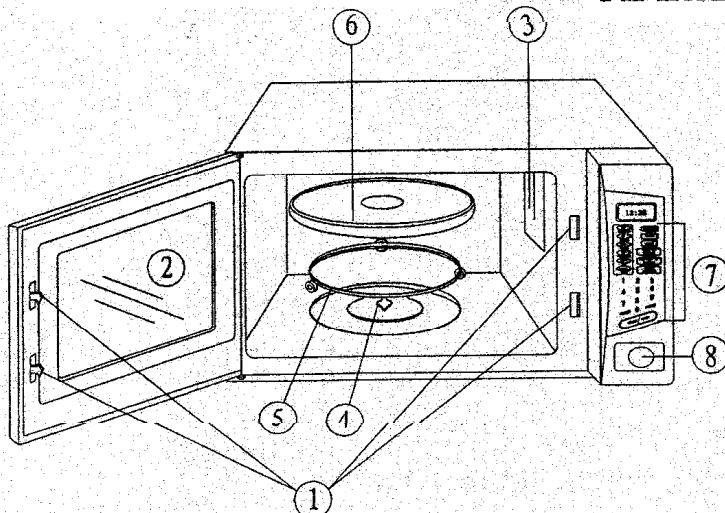

- ① Door Safety Lock
- ② Oven Window
- ③ Oven Air Vent
- ④ Shaft
- ⑤ Roller Ring
- ⑥ Glass Tray
- ⑦ Control Panel
- ⑧ Door Release Button

CONTROL PANEL

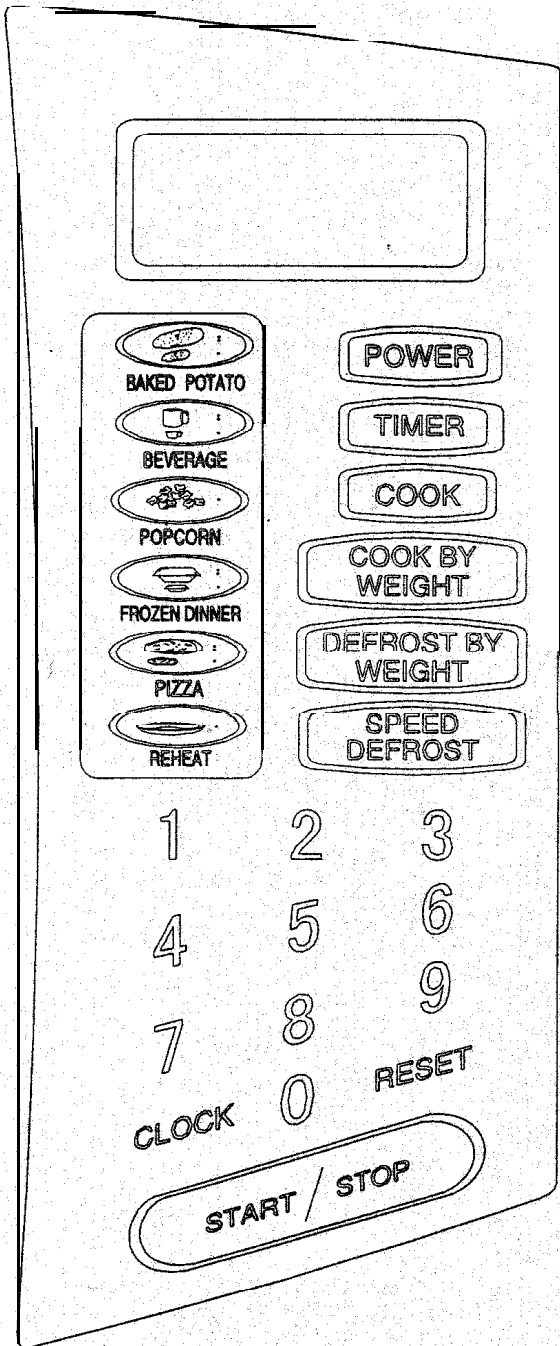

DISPLAY

Cooking time, power, indicators and present time are displayed.

BAKED POTATO BEVERAGE

POPCORN FROZEN DINNER

PIZZA REHEAT

Allows you to reheat or cook food automatically without entering power level or time.

POWER

Use to set power level.

TIMER

You can use the TIMER function independently, even while a cooking program is going on in the oven.

COOK

Cook at one power level for a period of time, then the oven automatically switches to another power level for the rest of cooking time.

COOK BY WEIGHT

Touch to enter weight of meat accurately. The oven automatically sets the cooking time and power level.

DEFROST BY WEIGHT

Touch to set the weight of the food to be defrosted; the oven automatically sets the defrosting time and *power level*.

SPEED DEFROST

Touch to set defrosting time; the oven automatically divides the defrosting time into periods of alternating defrost and stand times by cycling on and off.

(Also see following pages for more detail.)

NUMBER PADS (0-9)

Touch to set times or amounts.

CLOCK

Touch to set the clock.

RESET

Clears all previous settings if touched before cooking starts.

START/STOP

Touch to start or stop cooking.

OPERATING INSTRUCTIONS

BEEPS DURING OVEN SETTINGS

ONE BEEP: Oven accepts the entry.

TWO BEEPS: Oven **does** not accept the entry, check and try again.

SETTING THE CLOCK

1. Touch CLOCK pad.
2. Use the number pads to enter the correct time. You must touch at least three numbers to set the dock (one for -hour and two for minutes).
3. Touch CLOCK pad again.

NOTE:

This is a 12 hour clock. When the oven is first plugged in or when, power resumes after a power interruption, the display will show ENTER CLOCK TIME, if you prefer to not have the clock displayed, touch RESET pad. You can check the clock time while cooking is in progress by touching the CLOCK pad.

SETTING THE OVEN TIMER

1. Touch TIMER pad.
2. Enter the amount of time you want to count down by touching the number pads. Digit time is in minutes and

seconds and set left to right. Set one digit (a 5 for 5 seconds) or up to four digits (2405 for 24 minutes, 5 seconds).

3. Touch START/STOP pad.

NOTE:

- Time countdown can be seen in display for 3 seconds before clock or cooking time is returned to display.
- Touch TIMER and then touch RESET to cancel TIMER during timing process.

SETTING COOKING TIMES AND POWER LEVELS

A. One-stage Cooking

1. Use the number pads to set a cooking time. You can set a cooking time from one second to 99 minutes and 99 seconds. If you are setting a time greater than one minute, you must enter numbers for both minutes and seconds. For example, to set 20 minutes, enter 2,0,0,0.
2. If you want to set a power level other than 100% power, touch POWER, then use the number pads to enter the power level. You can set the power level

from 1 to 9.

3. Touch START/STOP to start cooking.

USE THESE SINGLE DIGIT TO REPRESENT POWER LEVELS	
Number pad	% of Power
9	90%
8	80%
7	70%
6	60%
5	50%
4	40%
3	30%
2	20%
1	10%

B. Two-stage Cooking

Some recipes require different stages of cooking at different temperatures.

1. SET STAGE 1:

Follow steps 1 and 2 in "One-stage Cooking".

DO NOT TOUCH START/STOP PAD.

2. SET STAGE 2:

Touch COOK pad then enter proper cooking time and (lower) power level.

(Most 2-stage recipes use lower power for second stage.)

3. Touch START/STOP pad.

N O T E :

After stage 1 time has elapsed, two beeps sound, signaling the beginning of stage 2. After total time has elapsed, 4 beeps sound and END appears in display. Touch RESET pad or open oven door to clear END.

SETTING "SPEED DEFROST"

1. Touch SPEED DEFROST pad.
2. Enter desired defrosting time by touching correct number pads. Digital

timer, sets minutes and seconds from left to right so a single digit can be set (5 for 5 seconds) or up to 4 digits (2405 for 24 minutes 5 seconds).

3. Touch START/STOP pad.

NOTE:

- After time has elapsed four beeps sound and END appears in display. Touch RESET pad or open door to clear END before starting another cooking function.
 - After setting SPEED DEFROST, oven can be programmed to automatically switch to one or two-stage cooking.
- A. For speed defrost and one stage cooking, follow steps above. Before touching START/STOP pad, touch COOK pad, enter time and power level. Then touch START/STOP pad.
- B. For speed defrost and two stage cooking, follow steps above. Before touching START/STOP pad, enter two-stage cooking programs.

SETTING "COOK BY WEIGHT"

1. Touch COOK BY WEIGHT pad.
2. Enter the one-digit code by touching the correct number pad..
3. Enter weight.
4. Touch START/STOP PAD.

NOTE:

- Your microwave oven makes cooking easy. You set the type and weight of food, and the oven automatically sets the time and power level.

"COOK BY WEIGHT" CODE DESCRIPTIONS		
CODE	TYPE	MAX WEIGHT
1	Beef	5 lb.
2	Mutton	5 lb.
3	Pork	5 lb.

- Meat must be defrosted and at refrigerated temperature.
- Weight must be in pounds and ounces. Ounce weights less than 10 must be preceded by a 0. If label gives weight in pounds only, change the fraction of a pound to ounces using the following chart.

CONVERTING FRACTIONS OF A POUND TO OUNCES	
FRACTIONS OF A POUND	OUNCES
Less than .03	0
.03 to .09	1
.10 to .15	2
.16 to .21	3
.22 to .27	4
.28 to .34	5
.35 to .40	6
.41 to .46	7
.47 to .53	8
.54 to .59	9
.60 to .65	10
.66 to .71	11
.72 to .78	12
.79 to .84	13
.85 to .90	14
.91 to .97	15
above .97	go to next even

- Turn meat over when oven beeps twice. Touch START/STOP to resume cooking.
- After total cooking time, 4 beeps sound and END appears in display. Touch

RESET or open oven door to clear END before starting another cooking function. Let meat stand a few minutes before carving.

SETTING "DEFROST BY WEIGHT"

1. Touch DEFROST BY WEIGHT pad.
2. Enter weight.
3. Touch START/STOP pad.

NOTE:

- Weight must be in-pounds and ounces. Ounce weights less than 10 must be preceded by a 0. If label gives weight in pounds only, change the fraction of a pound to ounces using the chart on this-page.
- Turn food over when oven beeps twice. Touch START/STOP pad to resume defrosting.
- After total defrosting time, 4 beeps sound and END appears in display. Touch RESET or open oven door to clear END before starting another cooking function.

SETTING "SAFETY LOCK"

The safety lock prevents unsupervised operation by little children. To set, press and hold RESET pad for 3 seconds, LOCK indicator lights. To cancel, press and hold RESET pad for 3 seconds, LOCK indicator goes off.

TO STOP THE OVEN WHILE THE OVEN IS OPERATING

1. Touch START/STOP pad.
 - YOU can restart the oven by touching START/STOP pad.
 - Touch RESET to erase all instructions.

2. Open the door.

- YOU can restart the oven by closing the door and touching START/STOP pad.

NOTE:

- Oven stops operating when door is opened.

ABOUT "QUICK COOK" SETTINGS

"QUICK COOK" allows you to cook or reheat food automatically without entering power level or time. When setting "quick cook"; check visual guide on pad for correct setting. Three "quick cook" settings allow you to cook several amounts of the same food. These include "FROZEN DINNER", "BAKED POTATO" and "BEVERAGE". After you touch these pads, ENTER AMT appears in the display.

In each "quick cook" category, smaller size food is set by touching pad once. One dot (.) below picture of smaller-size food signifies one touch of the pad. The large size can be set by touching the picture pad twice. Two dots (..) below the picture of large size food signifies two touches of the pad.

SETTING "POPCORN"

1. Touch POPCORN pad:
CODE and 1:45 (1 min. 45 sec.) appears in the display.
POPCORN automatically sets the cooking time for a 3 to 3 1/2 oz. bag of microwave popcorn.
2. Touch START/STOP pad.

NOTE:

- To reset POPCORN time: Tap POPCORN pad twice. ENTER TIME appears in display. Touch number pads to enter, minutes and seconds. Touch START/STOP pad. This new cooking time will remain whenever you touch the POPCORN pad until you reset it.

SETTING "BAKED POTATO"

For 4 to 6 oz. potatoes:

1. Touch POTATO pad once.
2. Enter number of potatoes by touching number pads from 1 to 4. Cooking times for small-medium potatoes are as follows:
 - 1 potato: 2 min. 10 sec.
 - 2 potatoes: 4 min. 10 sec.
 - 3 potatoes: 6 min. 10 sec.
 - 4 potatoes: 8 min. 10 sec.
3. Touch START/STOP pad.

For the large 8 to 10 oz. potatoes:

1. Tap POTATO pad twice.
2. Enter number of potatoes by touching number pads from 1 to 4. Cooking times for large potatoes are as follows:

- 1 potato: 4 min. 15 sec.
- 2 potatoes: 7 min. 40 sec.
- 3 potatoes: 11 min. 05 sec.
- 4 potatoes: 14 min. 30 sec.

3. Touch START/STOP pad.

SETTING "PIZZA"

Reheating a slice (or two thin ones) of leftover pizza:

1. Touch PIZZA pad once. CODE and 0:45 (45 sec.) appears.
2. Touch START/STOP pad.

Heating a whole frozen pizza:

1. Tap PIZZA. pad twice. CODE and 2:40 (2 -min. 40 sec.) appears.
2. Touch START/STOP pad.,,

SETTING "BEVERAGE"

For 5 to 7 oz. coffee cups:

1. Touch BEVERAGE pad once.
2. Enter number of cups by touching number pads from 1 to 4. Cooking times for coffee cups are as follows:
 - 1 cup: 1 min.. 00 sec.
 - 2 cups: 1 min. 50 sec.
 - 3 cups: 2 min. 40 sec.
 - 4 cups: 3 min. 30 sec.
3. Touch START/STOP pad.

For the larger 10 to 12 oz. coffee mugs:

1. Tap BEVERAGE pad twice.
2. Enter number of mugs by touching number pads from 1 to 4. Cooking times for coffee mugs are as follows:
 - 1 mug: 1 min. 35 sec.
 - 2 mugs: 3 min. 05 sec.

3 mugs: 5 min. 00 sec.

4 mugs: 6 min. 30 sec.,

3. Touch START/STOP pad.

SETTING "FROZEN DINNER!"

Microwaving one or two Small (7-9 OZ.)

frozen dinner(s):

1. Touch FROZEN DINNER pad once.
2. For 1 entree, just touch START/STOP. For 2 entrees, touch the number pad "2". Cooking times for small-size entrees are as follows:

1 entree: 4 min. 15 sec.

2 entrees: 7 min. 30 sec.

3. Touch START/STOP pad.

Microwaving one. Jarge (1 O-l 2 oz.) frozen dinner:

1. Tap FROZEN DINNER pad twice.
2. For 1 entree, just touch START/STOP. For 2 entrees, touch the number pad "2". Cooking times for larger entrees are as follows:
 - 1 entree: 6 min. 00 sec.
 - 2-entrees: 11 min. 00 sec.
3. Touch START/STOP pad.

SETTING "REHEAT"

1. Touch REHEAT pad. CODE and 3:00 (3 min. 00 sec.) appears.
2. Touch START/STOP pad.

NOTE:

This setting lets you reheat a dinner plate of chilled leftovers with good results.

CLEANING AND CARE

1. Turn off the oven and remove the power plug from the wall socket before cleaning.
2. Keep the inside of the oven clean. When food splatters or spilled liquids adhere to oven walls, wipe with a damp cloth. Mild detergent may be used if the oven gets very dirty. Avoid the use of spray and other harsh cleaners as they may stain, streak or dull the door surface.
3. The outside surfaces should be cleaned with a damp cloth. To prevent damage to the operating parts inside the oven water should not be allowed to seep into the ventilation openings.
4. Wipe the window on both sides with a damp cloth to remove any spills or splatters.
5. Do not allow the control panel to become wet. Clean with a soft, damp cloth. When cleaning the control panel, leave oven door open to prevent oven from accidentally turning on.
6. If steam accumulates inside or around the outside of the oven door, wipe with a soft cloth. This may occur when the microwave oven is operated under high humidity conditions, this is normal.
- 7. It is occasionally necessary to remove the glass tray for cleaning. Wash the tray in warm sudsy water or in a dishwasher.
8. The roller ring and oven floor should be cleaned regularly to avoid excessive noise. Simply wipe the bottom surface of the oven with mild detergent. The roller ring may be washed in mild sudsy water or dishwasher. When removing the roller ring from cavity floor for cleaning, be sure to replace in the proper position.
9. Remove odors from your oven by combining a cup of water with the juice and skin of one lemon in a deep bowl, microwave for 5 minutes. Wipe thoroughly and dry with a soft cloth.
- 1.0. When it becomes necessary to replace the oven light, please consult a dealer to have it replaced. Refer to the warranty card.

©2000 Sunbeam products, Inc.

Sunbeam is a registered trademark of Sunbeam Products, Inc. used under license.

Manufactured by Curtis International Ltd.

4600 Witmer industrial Estates, Unit 12, Niagara Falls, N.Y. 14305, USA.

For Call: 1-800-966-9653

NOTES/NOTAS

Free Manuals Download Website

<http://myh66.com>

<http://usermanuals.us>

<http://www.somanuals.com>

<http://www.4manuals.cc>

<http://www.manual-lib.com>

<http://www.404manual.com>

<http://www.luxmanual.com>

<http://aubethermostatmanual.com>

Golf course search by state

<http://golfingnear.com>

Email search by domain

<http://emailbydomain.com>

Auto manuals search

<http://auto.somanuals.com>

TV manuals search

<http://tv.somanuals.com>