

GAZCO



E-Studio[™] & *Logic E-box*[™]

With upgradable control valve

Instructions for Use, Installation and Servicing

For use in GB, IE (Great Britain and Eire)

IMPORTANT

The chimney must be swept before installation. Do not attempt to burn rubbish on this fire. This fire must only be operated with the glass window secured firmly in position. The front casing of this fire will become hot whilst in operation, it is therefore recommended that a suitable guard should be used for the protection of young children, the elderly or infirm.

Please read these instructions carefully before installation or use. Keep them in a safe place for future reference and when servicing the fire.

The commissioning sheet on page 3 **MUST** be completed by the Installer.

- Covering model number 8691CFCHUC and P8691CFCHUC for E-Studio
- Covering 8691MCUC 8691PBUC and P8691MCUC P8691PBUC for Logic E-Box

CONTENTS

	PAGE
APPLIANCE COMMISSIONING CHECKLIST	3
USER INSTRUCTIONS	4
INSTALLATION INSTRUCTIONS	11
Technical Specification for E-Studio	11
Technical Specification for Logic E-Box	12
Site Requirements	14
Installation	16
Commissioning	23
SERVICING INSTRUCTIONS	24
Servicing Requirements	24
Fault Finding	26
Replacing Parts	28
Spare Parts List for E-Studio	31
Spare Parts List for Logic E-Box	31
Service Records	32

APPLIANCE COMMISSIONING CHECKLIST

IMPORTANT NOTICE

Explain the operation of the fire to the end user, hand the completed instructions to them for safe keeping, as the information will be required when making any guaranteed claims.

FLUE CHECK	PASS	FAIL
1. Flue is correct for fire		
2. Flue flow test		
3. Spillage test		
GAS CHECK		
1. Gas soundness & let by test		
2. Standing pressure test	mb	
3. Fire working pressure (on High Setting) NB All other gas fires must be operating on full	mb	
4. Gas rate	m ³ /h	
5. Does ventilation meet fire requirements		
6. Have controls been upgraded (Upgradable models only)	8455 Standard	YES NO
	8456 Programmable Thermostatic and Timer	YES NO

DEALER AND INSTALLER INFORMATION

Dealer

Installation Company

.....

.....

.....

.....

Contact No.

Engineer

Date of Purchase

Contact No.

Model No.

Corgi Reg No.

Serial No.

Date of Installation

Gas Type

This product is guaranteed for 2 years from the date of installation, as set out in the terms and conditions of sale between Gazco and your local Gazco dealer. **This guarantee will be invalid, to the extent permitted by law, if the above Fire Commissioning Checklist is not fully completed by the installer and available for inspection by a Gazco engineer.** The guarantee will only be valid during the second year, to the extent permitted by law, if the annual service recommended in the Instructions for Use has been completed by a Corgi registered engineer, and a copy of the service visit report is available for inspection by a Gazco engineer.

USER INSTRUCTIONS

1. GENERAL

- 1.1 Installation and servicing must only be carried out by a competent person.
- 1.2 In all correspondence, please quote the fire type and serial number, which can be found on the data badge adjacent to the control knob.
- 1.3 Ensure that curtains are not positioned above the fire, and that there is a 300mm minimum clearance between the sides of the fire and any curtains.
- 1.4 This product is guaranteed for 2 years from the date of installation, as set out in the terms and conditions of sale between Gazco and your local Gazco dealer. Please consult with your local Gazco dealer if you have any questions. In all correspondence always quote the Model Number and Serial Number.
- 1.5 The decorative front and glass become hot during normal use and should be treated as a 'working surface'. It is therefore recommended that a suitable fire guard be used for protection of young children and the infirm.
- 1.6 If any cracks appear in the glass panel do not use the fire until the panel has been replaced.

2. LIGHTING THE FIRE

- 2.1 Locate the control valve on the fire. There are two control knobs on the valve, the right-hand knob controls the pilot ignition and the left hand knob controls the main burner.
- 2.2 If your fire has already been upgraded to battery remote control, please refer to the instructions provided with the upgrade to operate the remote control. The following instructions work for either situation.

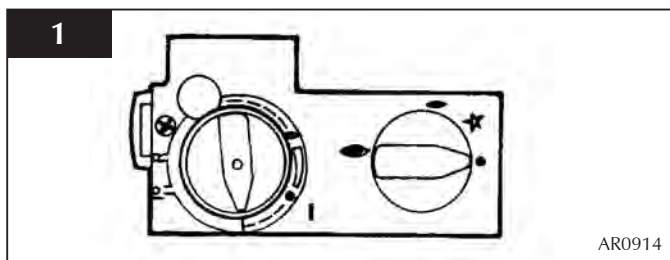

- Ensure that the left-hand control knob is pointing to off (●).
 - Ensure that the right-hand control knob is pointing to off (●).
 - Press in the right-hand control knob and rotate it left until a click is heard
 - Keep pressing in and the knob is pointing to pilot (☞)
- The pilot should now light. If the pilot has not lit, repeat the procedure until it does.
- Hold the control knob pressed in 10 seconds and then release it
- The pilot should stay alight. If the pilot goes out, repeat the steps.

- 2.3 If the pilot does not light after repeated attempts, contact the retailer or installer from whom the fire was purchased.
- 2.4 Turn the right-hand control to point to main burner (☞). The fire can now be controlled using the left-hand control knob.
- 2.5 Turn the left-hand control knob to point to low fire (☞), the main burner now lights on low. The burner can now be controlled between low and high settings. Turn the control knob anti clockwise to increase the flame height and clockwise to decrease the height.
- 2.6 **If the pilot flame is extinguished, intentionally or unintentionally, do not relight the appliance for at least 3 minutes.**

3. TURNING THE FIRE OFF

- 3.1 To turn the fire off, locate the control valve, turn the left-hand control knob until it points to off (●). The main burner goes out leaving the pilot burning.
- 3.2 To turn the pilot off, locate the control valve, turn the right-hand control knob until it points to off (●). The pilot will go out.

4. UPGRADING YOUR FIRE

- 4.1 Your fire is fitted with a control valve that can easily be upgraded to battery powered remote control. This upgrade can be fitted by anyone capable of simple DIY jobs and requires no special training. This upgrade can be obtained through your local Gazco stockist.
- 4.2 **STANDARD REMOTE CONTROL** This remote control can control the fire after the pilot has been lit. It can turn the main burner on and regulate it from low through to high and back again. It can turn the main burner off leaving the pilot burning GAZCO PART NUMBER 8455.
- 4.3 **PROGRAMMABLE THERMOSTATIC AND TIMER REMOTE CONTROL.** This remote control can control the gas fire after the pilot has been lit. In **MANUAL MODE** it can be used to turn the main burner on and manually regulate it from low through to high and back again. It can be used to turn the main burner off, leaving the pilot burning. In **AUTO MODE** it will automatically regulate the room temperature to a preset temperature. In **TIMER MODE** it will turn the fire on and off according to preset programme and automatically regulate the room temperature during the two periods. GAZCO PART NO. 8456.

USER INSTRUCTIONS

5. CLEANING THE E-STUDIO

MAKE SURE THE FIRE AND SURROUND ARE COOL BEFORE TRYING TO CLEAN.

- 5.1 Remove the glass window by unscrewing the four screws in the retaining bracket, Diagram 2.

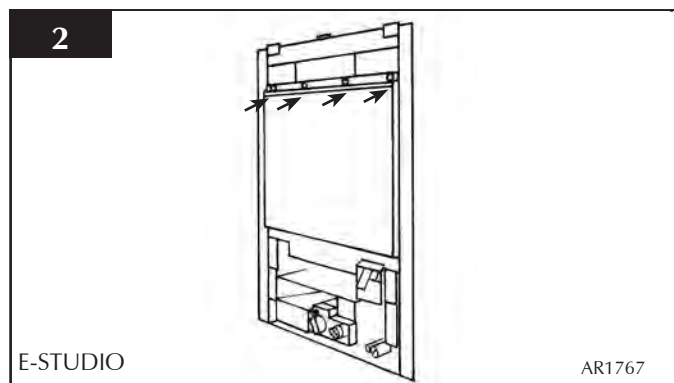

- 5.2 To clean the glass surface, Gazco recommends you use a ceramic glass product generally sold for cleaning ceramic hobs.
- 5.3 Remove the granite chippings and place on a dry clean surface. Do not remove the enamel back panel. Use a damp cloth and mild non abrasive cleaner on the enamel back panel.
- 5.4 Clean the burner and tray assembly using a vacuum cleaner with a soft brush attachment. Ensure all debris is removed from the burner ports.
- 5.5 Replace the granite chippings by referring to Section 7 for E-Studio.

6. CLEANING THE LOGIC-E BOX

MAKE SURE THE FIRE AND SURROUND ARE COOL BEFORE TRYING TO CLEAN.

- 6.1 Remove the glass window by unscrewing the four screws in the retaining bracket, Diagram 3.
- 6.2 To clean the glass surface, Gazco recommends you use a ceramic glass product generally sold for cleaning ceramic hobs.

3

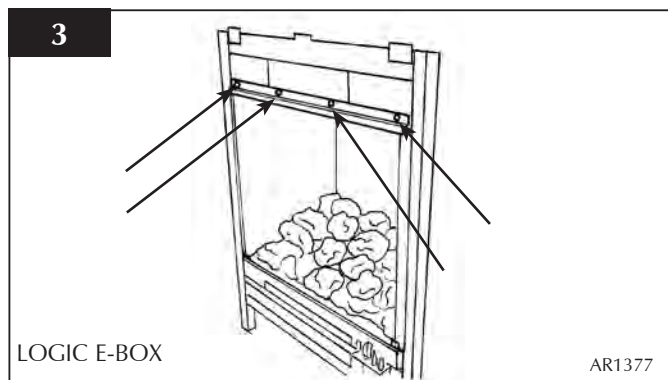

- 6.3 Remove the ceramic coals and place on a dry, clean surface. Remove the fuel bed and burner cover gasket.
- 6.4 Clean the burner and tray assembly using a vacuum cleaner with a soft brush attachment, Ensure all debris is removed from the burner ports.
- 6.5 Replace the ceramics by referring to Section 8 for the Logic E-Box arrangement of components.

7. E-STUDIO ARRANGEMENT OF FUEL BED COMPONENTS

ONLY USE THE CORRECT TYPE AND QUANTITY OF GRANITE CHIPPINGS. ALWAYS FOLLOW THE FUEL BED LAYOUT AS STATED IN THESE INSTRUCTIONS. NEVER CHANGE THE LAYOUT FROM THAT SHOWN HERE.

- 7.1 Arrange the granite chippings in the areas highlighted in Diagram 4. Granite chippings should be evenly distributed.

4

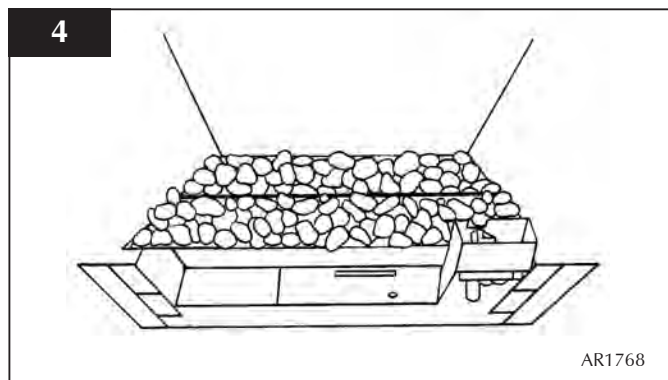

USER INSTRUCTIONS

- 7.2 Lean the granite chippings against the burner ledges to disguise the ledges.

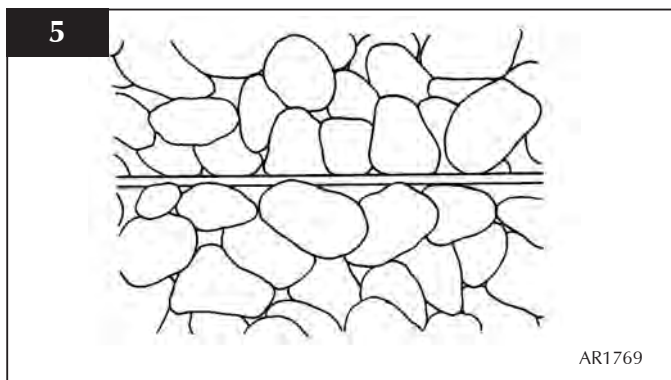

- 7.3 Check that the port area. Arrow A, is clear of granite chippings. This can be easily done by gently running a screwdriver or similar object along this area. Diagram 6.

NOTE: IT IS IMPORTANT THE GRANITE CHIPPINGS DO NOT COVER THE PORT AREA IN BETWEEN THE BURNER LEDGES.

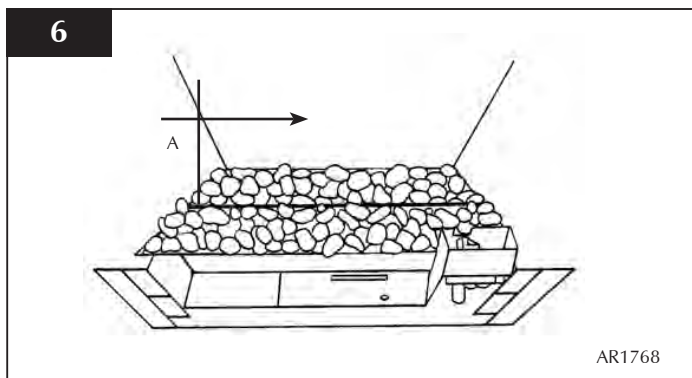

- 7.4 Ensure that no chippings over-hang or fill the pilot area, Arrow B, Diagram 7.

NOTE: CHIPPINGS SHOULD NOT BE PLACED DIRECTLY IN FRONT OF THE PILOT CROSS LIGHTING FLAME.

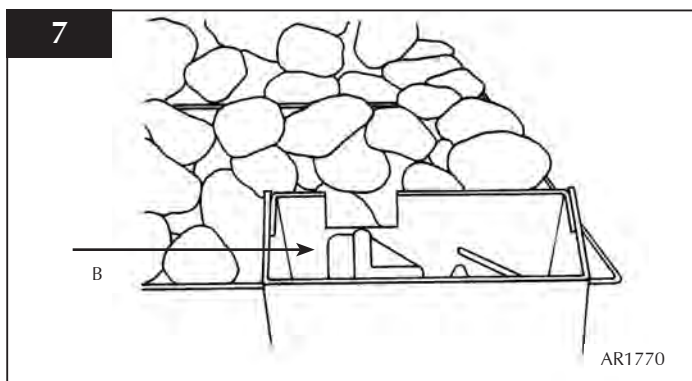

- 7.5 Ensure that the fibre glass window seal on the box is intact. Lower the glass window into the hooks on the box. Secure the window using four screws in the retaining bracket, Diagram 8.

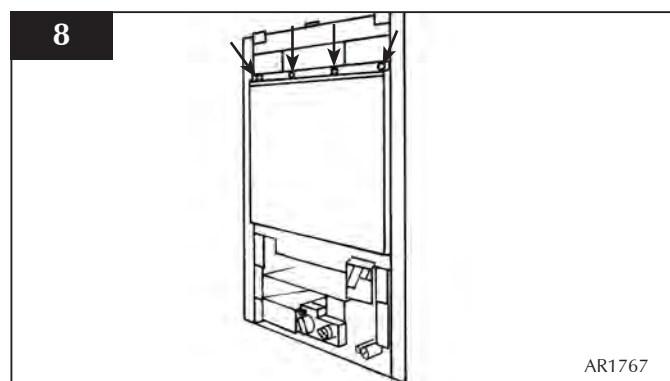

NEVER OPERATE THE FIRE WHEN THE GLASS PANEL IS REMOVED OR BROKEN.

USER INSTRUCTIONS

8. LOGIC E-BOX ARRANGEMENT OF FUEL BED COMPONENTS

ADVICE ON HANDLING AND DISPOSAL OF FIRE CERAMICS

The fuel effect and side panels in this fire are made from Refractory Ceramic Fibre (RCF), a material which is commonly used for this application.

Preventive clothing is not required when handling these articles, but we recommend you follow normal hygiene rules of not smoking, eating or drinking in the work area, and always wash your hands before eating or drinking.

To ensure that the release of RCF fibres is kept to a minimum during installation and servicing, a HEPA filtered vacuum is recommended to remove any dust accumulated in and around the fire before and after working on it.

When servicing the fire it is recommended that the replaced items are not broken up, but are sealed within heavy duty polythene bags and labelled as RCF waste.

RCF waste is classed as stable, nonreactive hazardous waste, and may be disposed of at a licensed landfill site.

Excessive exposure to these materials may cause temporary irritation to eyes, skin and respiratory tract; wash hands thoroughly after handling the material.

NOTE: CERAMIC PARTS ARE FRAGILE. THE SIDE AND REAR PANELS ARE REVERSIBLE. ONE SIDE IS PLAIN, THE OTHER SIDE IS REEDED. ONLY USE THE CORRECT TYPE AND QUANTITY OF CERAMIC COMPONENTS. ALWAYS FOLLOW THE FUEL BED LAYOUT AS STATED IN THESE INSTRUCTIONS. NEVER CHANGE THE LAYOUT FROM THAT SHOWN HERE.

- 8.1 Position the burner cover gasket on the burner skin ensuring the holes align with the ports. Take care as the front left-hand hole is offset compared to the others. Diagram 9, arrow A.

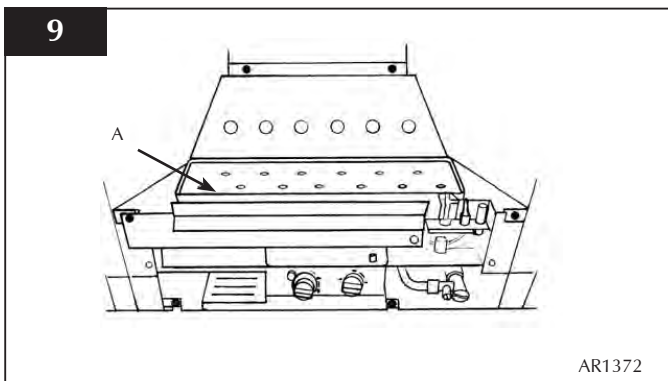

- 8.2 Place the rear panel against the rear of the box resting on the shelf. Slide one of the side panels into the box ensuring it touches the rear panel. Then gently ease the front edge of the side panel behind the flange so it lies flat against the wall of the box. Repeat with the second side panel, Diagram 10.

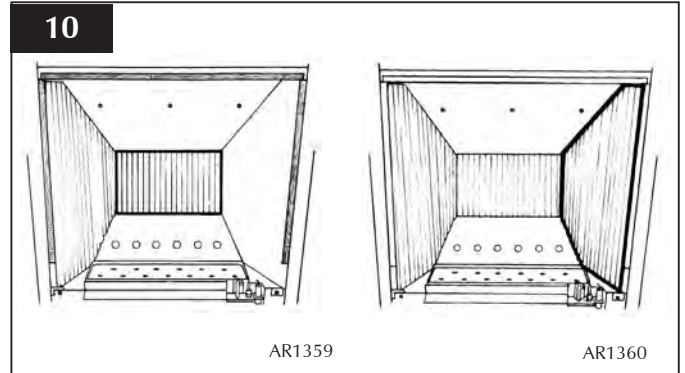

- 8.3 Locate the top panel on top of the sides and rear by lifting it up and forward inside the box, then sliding it backwards and down behind the side panels and to rest on the rear panel. See diagram 11.

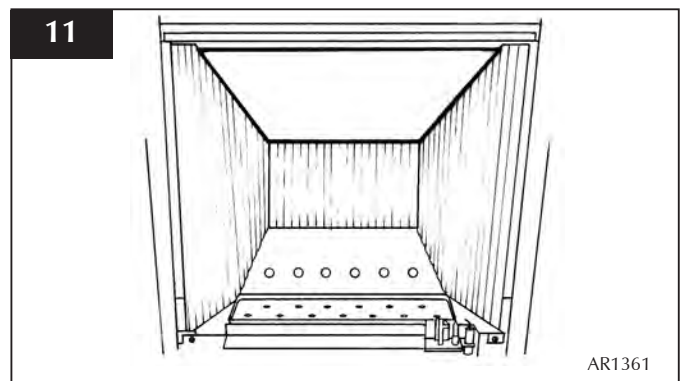

Coal Layout

- 8.4 Position the flame baffle centrally on the tray and ensure the stepped lower edge engages against the rear edge of the burner skin., Diagram 12.

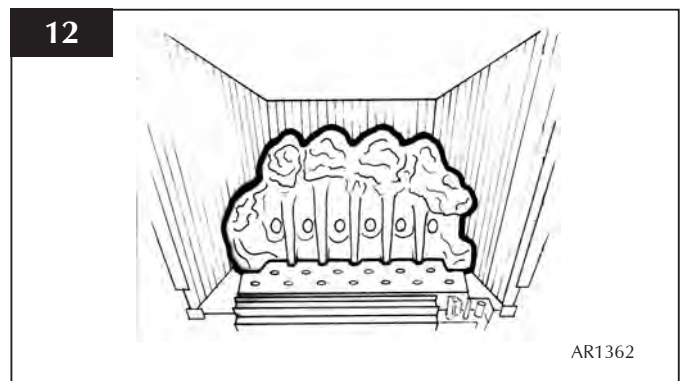

- 8.5 Place the front coal centrally in the channel at the front of the tray, Diagram 13. The relationship between the front coal and the flame baffle is shown in diagram 13.

USER INSTRUCTIONS

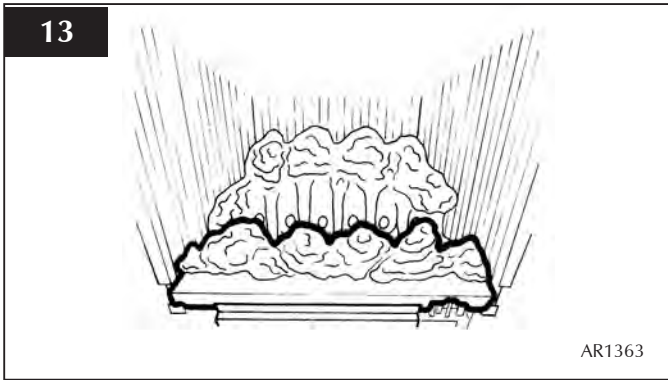

8.6 There are three sizes of coal used. Small, medium and large. See diagram 14 for identification.

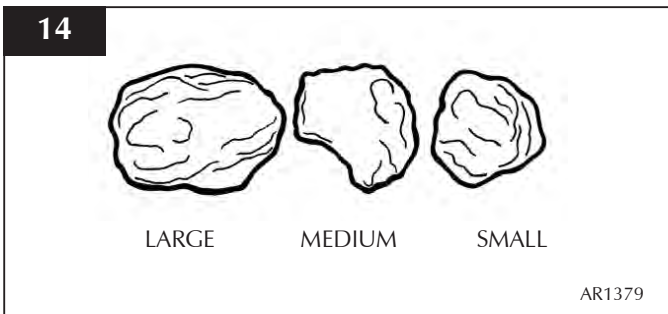

8.7 Place the single large coal in the depression in centre of the front coal resting against the flame baffle, Diagram 15.

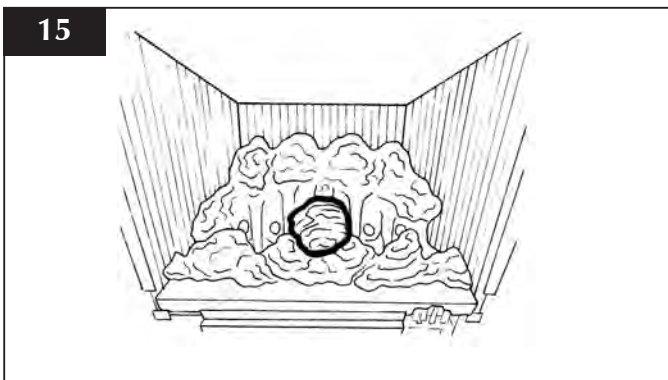

8.8 Place a medium size coal either side of the first large one, in the depressions in the front coal. Resting between the flame baffle and the front coal, Diagram 16

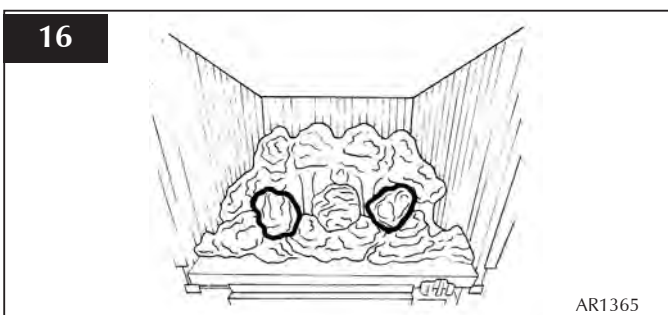

8.9 Place another two medium size coals resting behind the first three coals and against the flame baffle, Diagram 17.

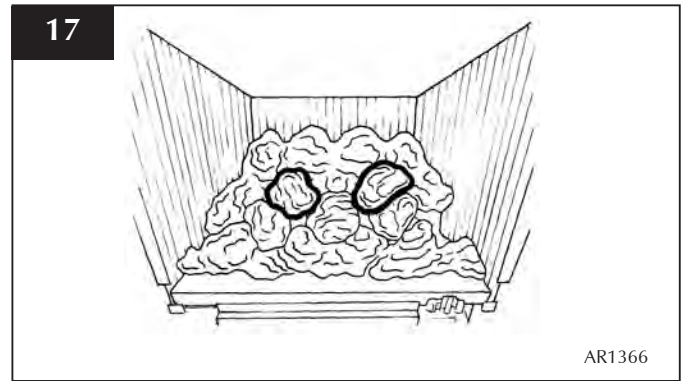

8.10 Place a small coal directly behind the first large coal, and in between the centre of the last two medium coals resting on the flame baffle, Diagram 18.

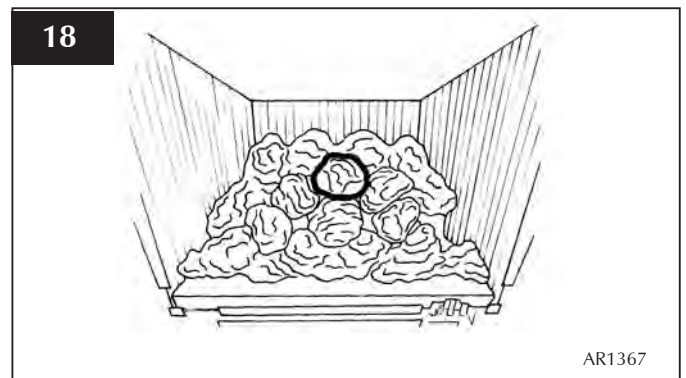

8.11 Place two small coals to the left and right-hand side of the bed in the two remaining spaces, Diagram 19.

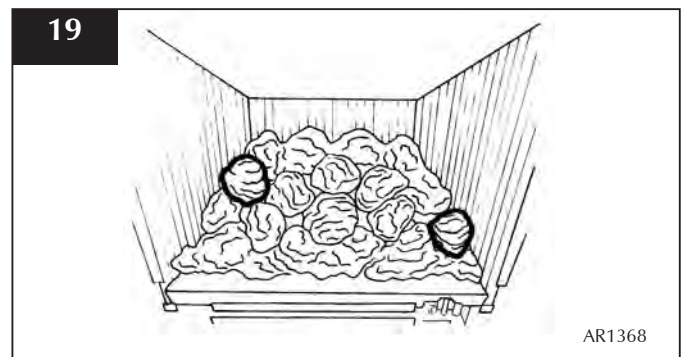

USER INSTRUCTIONS

Pebble Layout

- 8.12 Position the pebble flame baffle centrally on the tray and ensure the stepped lower edge engages against the rear edge of the burner skin, Diagram 20.

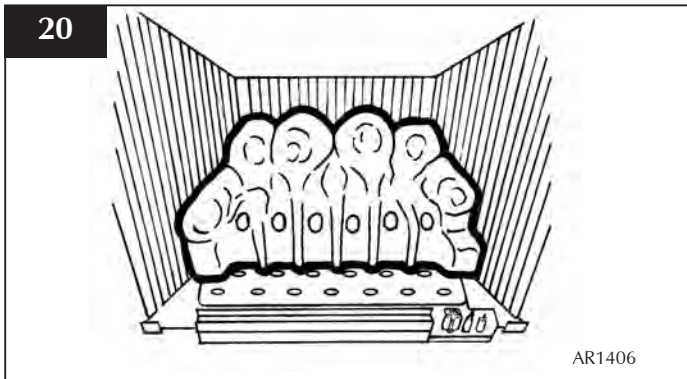

- 8.13 Place the front pebble piece centrally in the channel at the front of the tray, Diagram 21.

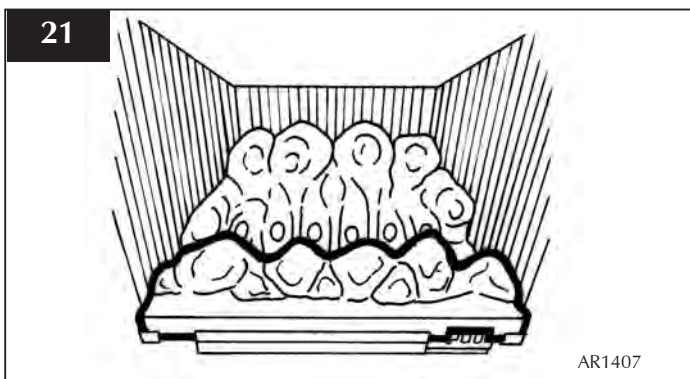

- 8.14 Place the four pebbles as identified resting between the front ceramic and the flame baffle as shown in Diagram 22.

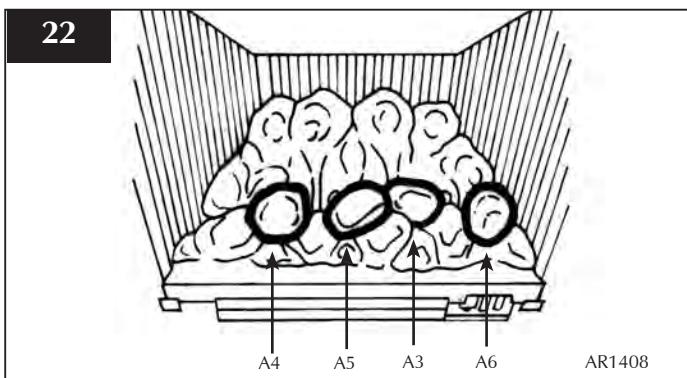

- 8.15 Place the next four pebbles as identified resting between the flame baffle and the first row of pebbles as shown in Diagram 23.

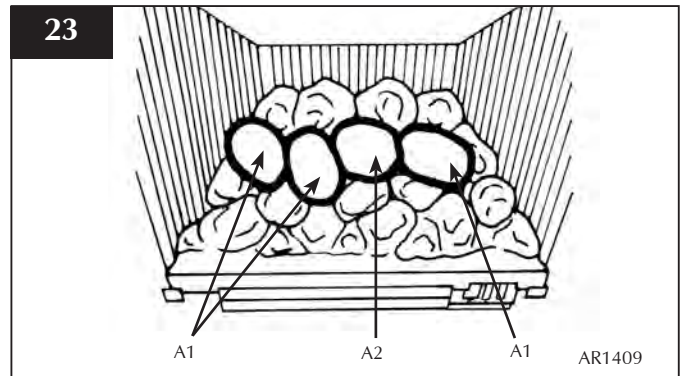

- 8.16 Place the remaining two pebbles identified as shown in diagram 24.

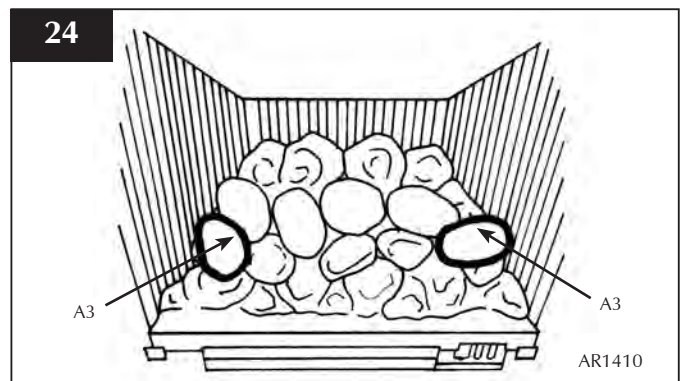

- 8.17 The coals/pebbles should evenly cover the whole bed with the gaps between them kept equal. This maximises the performance of the product

- 8.18 ENSURE THAT THE COALS/PEBBLES ARE POSITIONED AS ABOVE. ONLY USE THE CORRECT AMOUNT OF COALS/PEBBLES AS SPECIFIED IN THE DIAGRAMS.

- 8.19 Ensure that the fibre glass window seal on the box is intact, then lower the glass window into the hooks on the box. Secure the window using four screws in the retaining bracket, diagram 25.

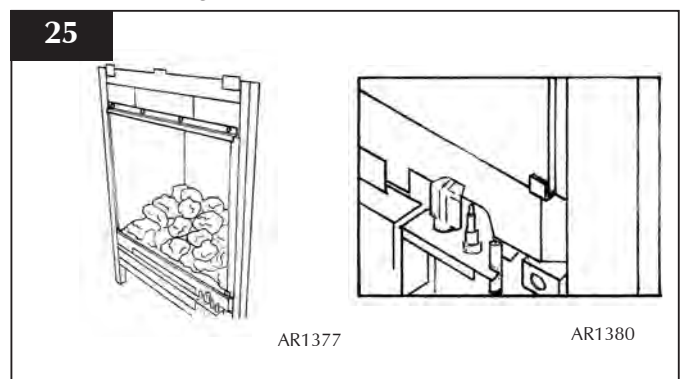

- NEVER OPERATE THE FIRE WHEN THE GLASS PANEL IS REMOVED OR BROKEN.**

USER INSTRUCTIONS

10. OXYGEN DEPLETION SENSOR

The fire is fitted with an oxygen sensitive pilot system that will act to cut off the gas supply to the fire should the oxygen in the room fall below its normal level. If the fire is turned off by this device, it usually indicates that there is a problem with the flue system, and this should be inspected by a qualified engineer. **Do not attempt to use the fire until an engineer says it is safe to do so.**

This device is not a substitute for an independently mounted carbon monoxide detector.

11. FLAME FAILURE DEVICE

This is a safety feature incorporated in all GAZCO fires which automatically switches off the gas supply if the pilot light goes out and fails to heat the thermocouple.

12. RUNNING IN

The surface coating on the coals used in your GAZCO fire will burn off during the first few hours of use, producing a harmless and temporary odour. This will disappear after a short period of use. If the odour persists, ask your installer for advice.

13. SERVICING

The fire must be serviced every 12 months by a qualified Gas Engineer. In all correspondence, always quote the fire type and serial number, which may be found on the data badge located on chain beneath the control valve.

14. VENTILATION

Any purpose provided ventilation should be checked periodically to ensure that it is free from obstruction.

15. INSTALLATION DETAILS

To assist in any future correspondence, your installer should have completed the commissioning sheet at the front of this manual. In all correspondence always quote the Model Number and Serial Number.

INSTALLATION INSTRUCTIONS

TECHNICAL SPECIFICATION

**E-STUDIO models: 8691CFCHUC
P8691CFCHUC**

GAS CATEGORY		I ₂ H	I ₃ P
		Natural	Propane
Gas Type		G20	G31
Working Pressure		20mbar	37mbar
Gross Input kW	HIGH	4.3kW	4.1kW
	LOW	2.5kW	2.3kW
Gas Rate m ³ /hr		0.41	0.153
Efficiency Class		2	2
NO _x Class		4	4
Injector Size		240	102
Aeration Size		6 x 6mm	12mm x 15mm
Min Flue Size		5" Diameter	
Min Flue Size - Pre-cast		90mm x 183mm (16500mm ²)	
Min Flue Specification		T260/N2/0/D/1	
Gas Inlet		8mm	

APPLICABLE FRONTS	
Front	Part Number
Designio	8272MA, 8272IR, 8272GP
Progress	8253MA, 8253IR
Dimension	8680MB
Steel	8695GP, 8695IR
Evolution	8258BS
	8258MB

APPLICABLE FRAME & FRONT COMBINATIONS		
FINISH	ARTS FRAME	ARTS FRONT
Black	8283MB	8282MB
Brass	8283PBR	8282PBR
Brushed Steel	8283BS	
Polished Steel	8283P	
Highlight Polished		8282HP
Chrome		8282P

INSTALLATION INSTRUCTIONS

TECHNICAL SPECIFICATION

LOGIC E-BOX models:

8691 MCUC 8691PBUC
P8691 MCUC P8616PBUC

GAS CATEGORY		I ₂ H	I ₃ P	
		Natural	Propane	
Gas Type		G20	G31	
Working Pressure		20mbar	37mbar	
Gross Input kW	HIGH	5.1kW	4.8kW	
	LOW	2.5kW	2.5kW	
Gas Rate m ³ /hr		0.486	0.181	
Efficiency Class		2	2	
NO _x Class		3	3	
Injector Size		300	150	
Aeration Size	Coal	Pebble	Coal	Pebble
	5mm x 16mm	10mm x 16mm	(1) 10mm x 16mm (1) 23mm x 15mm	(1) 14mm x 15mm (1) 23mm x 15mm
Min Flue Size		5" Diameter		
Min Flue Size - Pre-cast		90mm x 183mm (16500mm ²)		
Min Flue Specification		T260/N2/0/D/1		
Gas Inlet		8mm		

APPLICABLE FRONTS	
Front	Part Number
Designio	8272MA, 8272IR, 8272GP
Evolution	8258BS
	8258MB
Infinity	8256BS
Progress	8253MA, 8253IR
Richmond	8679
Dimension	8680MB

APPLICABLE FRAME & FRONT COMBINATIONS				
FINISH	** ARTS FRAME	ARTS FRONT	HOLYROOD	SPANISH
Black	8283MB	8282MB	8693MB	8694MB
Brass	8283PBR	8282PBR		
Black/Brass			8693PBB	8694PBB
Brushed Steel	8283BS			
Polished Steel	8283P			
Highlight Polished		8282HP	8693HP	8694HP
Chrome		8282P		

** The Arts Frame must be used in conjunction with either the Arts, Holyrood or Spanish Front.

INSTALLATION INSTRUCTIONS

TECHNICAL SPECIFICATION

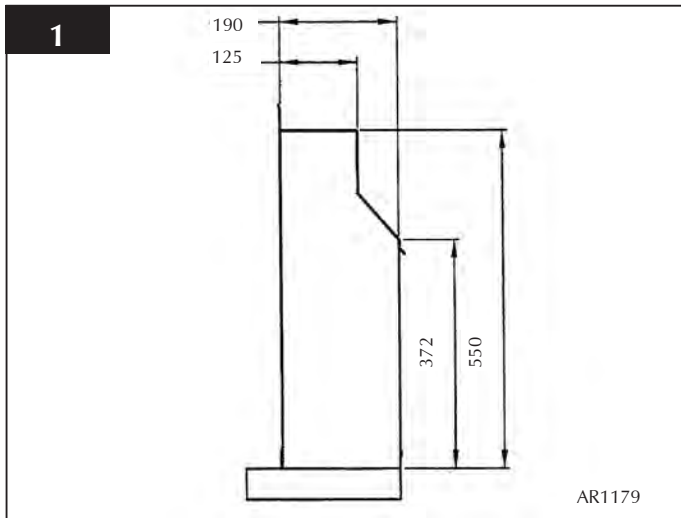

**OVERALL EXTERNAL
DIMENSIONS
SIDE VIEW**

**MINIMUM DEBRIS COLLECTION
SPACE REQUIREMENTS-
(EXISTING MASONRY CHIMNEYS ONLY)**

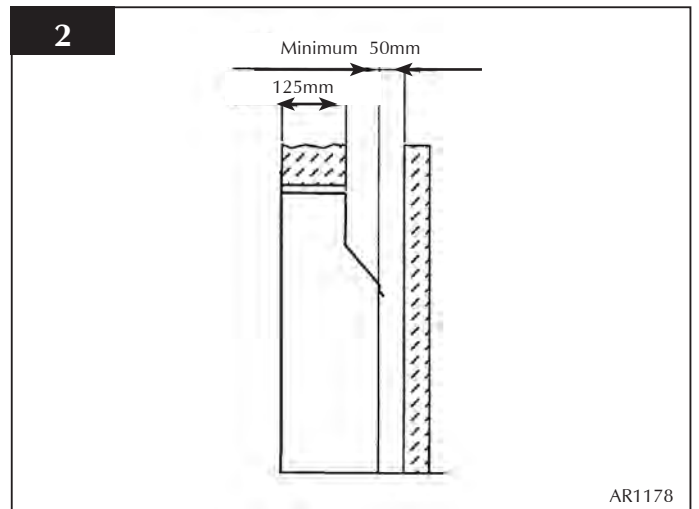

**OVERALL EXTERNAL
DIMENSIONS
PLAN VIEW**

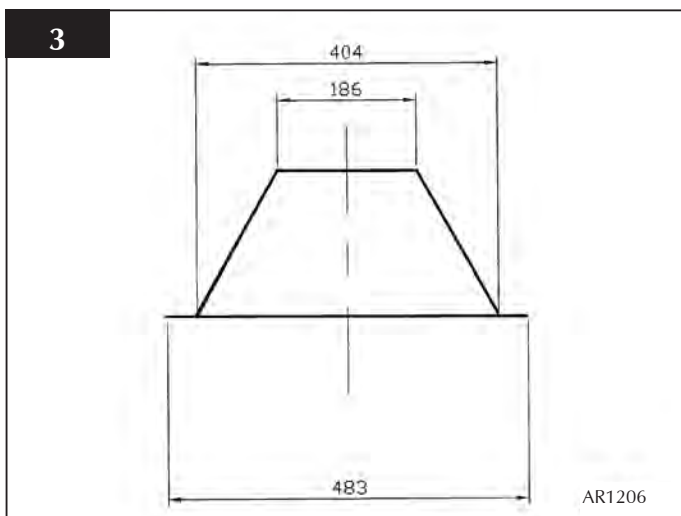

INSTALLATION INSTRUCTIONS

SITE REQUIREMENTS

1. FLUE AND CHIMNEY REQUIREMENTS

- 1.1 The chimney or flue system must comply with the rules in force, and must be a minimum of 125mm (5") in diameter. Precast flues must conform to BS1289: 1986. The cross sectional area of the flue must be 16500 mm² with a minimum dimension of 90mm.

*When fitting the fire to a precast flue, the total minimum depth of fire opening necessary is (D) 215mm. This allows a 25mm space behind the fire for debris, required on this type of flue system. This is achieved either by using = (A) a 115mm deep starter block + (B) a 25mm plasterboard and sealed space + (C) 75mm Gazco Spacer (part number 8315) with a marble slip or similar, inserted behind the spacer front flange, see diagram 1.

Or the total depth can be achieved by using a deeper starter block, remedial building work to the front of the fireplace opening, and a marble slip or similar, or a combination of this.

NEVER PLASTER DIRECT TO THE FACE OF A PRECAST FLUE. USE ADHESIVE TO FIX THE PLASTERBOARD TO THE FACE OF THE FLUE AND FINALLY SKIM THE PLASTERBOARD.

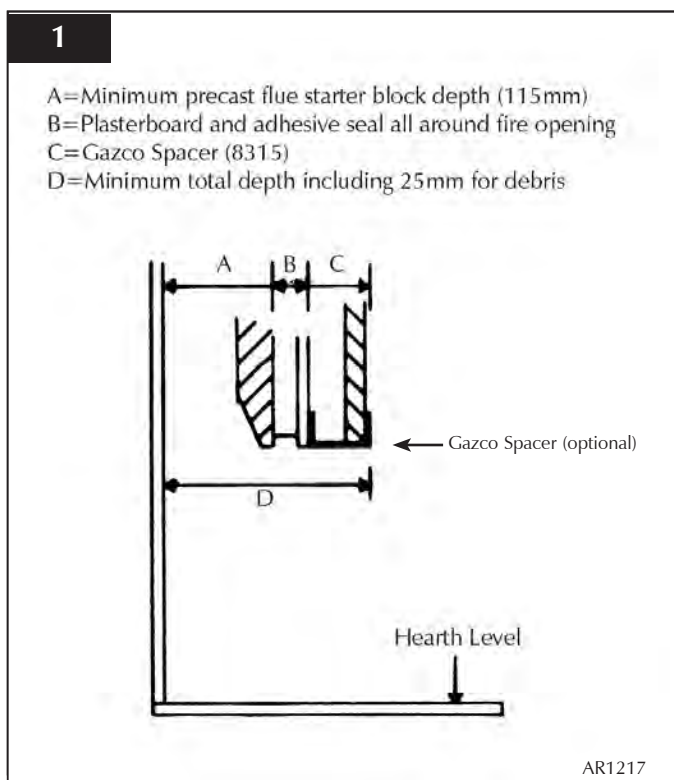

The fire can also be fitted into a metal flue box with a 5" (125mm) diameter flexible liner. In this installation a 1" (25mm) rebated fire surround must be used. Refer to diagram 2 for dimensions.

- 1.2 The minimum effective height of the flue or chimney must be 3 m (10ft).

- 1.3 The chimney or flue must be free from any obstruction. Any damper plates should be removed or secured in the fully open position, and no restrictor plates should be fitted.
- 1.4 The chimney should be swept immediately prior to the installation of the fire - unless it can be seen to be clean and unobstructed throughout its entire length.
- 1.5 Ensure that there is a smooth taper transition from the fireplace opening into the chimney or flue.
- 1.6 The flue pull should be checked prior to installation of the fire. Apply a smoke pellet to the flue or chimney opening and ensure that the smoke is drawn into the opening. If there is not a definite flow, preheat the chimney for a few minutes and re-test the flow.

IF THERE IS STILL NO DEFINITE FLOW, THE CHIMNEY MAY REQUIRE ATTENTION - SEEK EXPERT ADVICE.

2. FIRE LOCATION

- 2.1 This fire must stand on a non-combustible hearth that is at least 12mm thick and 50mm thick at least at the periphery. If the fire is installed greater than 50mm above the floor, then no hearth is required, although due consideration should be given to how the heat may affect the floor material.
- 2.2 NOTE: It is recommended you construct the back panel of the fireplace from natural materials cut into three or more sections to prevent cracking. Resin-based materials may not be suitable. This appliance is an effective heat producer and attention must be paid to the construction and finish of the fireplace.
- 2.3 It must be fitted into a non-combustible opening.
- 2.4 These fires must be hearth mounted into a fireplace opening conforming to National Standards. The minimum dimensions shall be as shown in diagram 2.

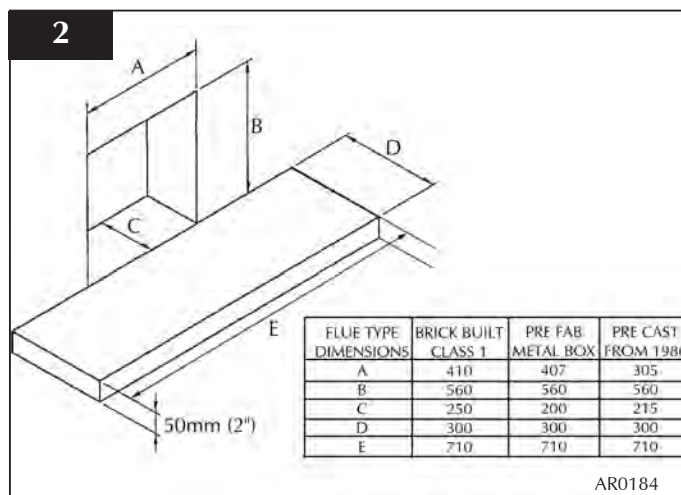

INSTALLATION INSTRUCTIONS

SITE REQUIREMENTS

- 2.5 Ensure that no naked flame or incandescent part of the fire bed projects beyond the vertical plane of the fireplace opening.
- 2.6 The fire must not be installed in any room that contains a bath or shower.
- 2.7 Ensure clearances to combustible materials - see diagram 3.

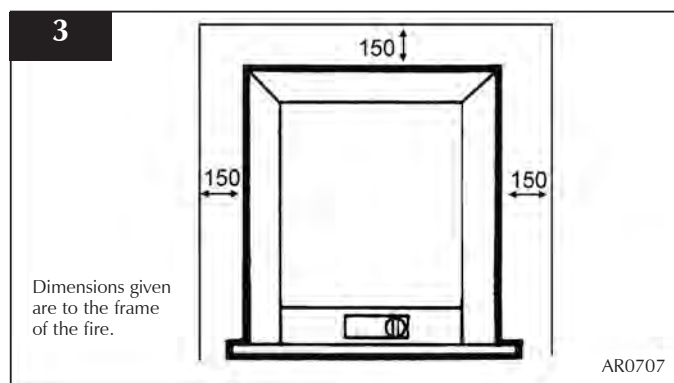

- 2.8 The maximum depth of combustibile shelf is 150mm at a minimum height of 150mm above the frame.

Refer to the appropriate Frame Instructions regarding additional wall strengthening for the frame.

3. GAS SUPPLY

- 3.1 Before installation, ensure that the local distribution conditions (identification of gas and pressure) and the adjustment of the fire are compatible.
- 3.2 Ensure that the gas supply is capable of delivering the required amount of gas, and is in accordance with the rules in force.
- 3.3 This fire is supplied complete with a factory fitted isolation device incorporated into the inlet connection, no further isolation device is therefore required.

4. VENTILATION

It is important to ensure that any national ventilation requirements are taken into account during the installation of this fire.

- 4.1 This fire has a nominal input not exceeding 7.0kw and therefore does not normally require any additional permanent ventilation.

If, however, spillage is detected when commissioning the fire, there may be insufficient natural ventilation and additional ventilation may be required.

For ventilation requirements in the Republic of Ireland, it will be necessary to refer to the relevant rules in force.

AIR VENTS MUST NOT BE RESTRICTED.

INSTALLATION INSTRUCTIONS

INSTALLATION

1. UNPACKING

- 1.1 Remove the fire from its packaging, and check that it is complete and undamaged.
- 1.2 Put the loose ceramic parts to one side so that they are not damaged during installation.

2. CONTROL UPGRADE

- 2.1 Your fire is fitted with a control valve that can be easily upgraded to battery powered remote control. This upgrade can be fitted by anyone capable of simple DIY jobs and requires no special training. This upgrade can be obtained through your local Gazco stockist.
- 2.2 **STANDARD REMOTE CONTROL** This remote control can control the fire after the pilot has been lit. It can turn the main burner on and regulate it from low through to high and back again. It can turn the main burner off leaving the pilot burning. GAZCO PART NUMBER 8455.
- 2.3 **PROGRAMMABLE THERMOSTATIC AND TIMER REMOTE CONTROL.** This remote control can control the gas fire after the pilot has been lit. In **MANUAL MODE** it can be used to turn the main burner on and manually regulate it from low through to high and back again. It can be used to turn the main burner off, leaving the pilot burning. In **AUTO MODE** it will automatically regulate the room temperature to a preset temperature. In **TIMER MODE** it will turn the fire on and off according to preset programme and automatically regulate the room temperature during the two periods. GAZCO PART NO. 8456.

3. SAFETY PRECAUTIONS

- 3.1 This fire must be installed in accordance with the rules in force, and used only in a sufficiently ventilated space. Please read all instructions before installation and use of this fire.
- 3.2 These instructions must be left intact with the user.
- 3.3 Do not attempt to burn rubbish on this fire.
- 3.4 In your own interest, and those of safety, this fire must be installed by a competent person in accordance with local and national codes of practice. Failure to install the fire correctly could lead to prosecution.
- 3.5 Keep all plastic bags away from young children.

4. INSTALLATION OF THE GAS SUPPLY

NATURAL GAS @ 20mbar	PROPANE @ 20mbar
8691CFCHUC	P8691CFCHUC
8691MCUC	P8691MCUC
8691PBUC	P8691PBUC

TO CHANGE FROM ONE GAS TYPE TO ANOTHER A COMPLETE ENGINE ASSEMBLY AND DATA BADGE WILL BE REQUIRED. SEE SECTION 8 SERVICING INSTRUCTIONS.

- 4.1 Before installation, ensure that the local distribution conditions (identification of the type of gas and pressure) and the adjustment of the fire are compatible. See above tables.
- 4.2 Ensure that the gas supply is capable of delivering the required amount of gas and is in accordance with the rules in force. Please refer to the technical specification for the correct working pressure for the gas used.
- 4.3 Soft copper tubing and soft soldered joints can be used but must not be closer than 50mm (2") to the underside of the burner.
- 4.4 An isolation device is provided with the fire.
- 4.5 All supply gas pipes must be purged of any debris that may have entered, prior to connection to the fire.
- 4.6 This appliance is intended for use on a gas installation with a governed meter.

5. PREPARING THE FIRE

- 5.1 Remove the glass window by unscrewing the four screws in the retaining bracket. See diagram 1.

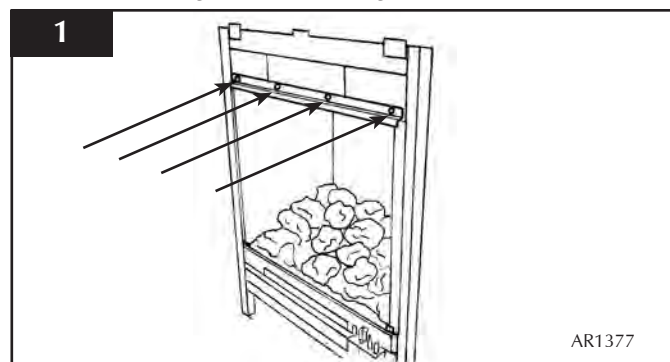

- 5.2 Remove the five burner retaining screws and withdraw the burner unit from its location, Diagram 2.

NOTE: IF REMOVING THE E-STUDIO BURNER, IT WILL BE NECESSARY TO REMOVE THE DECORATIVE INNER PANEL, SEE SECTION 7

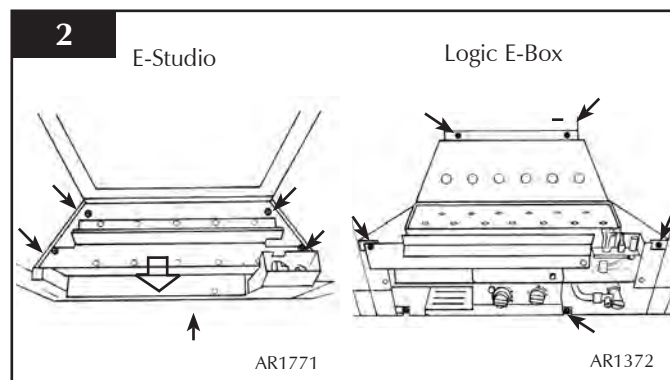

INSTALLATION INSTRUCTIONS

INSTALLATION

- 5.3 Decide on the retention method. If cable fixings are to be used remove the lower cover plate by unscrewing the three screws., Diagram 3.

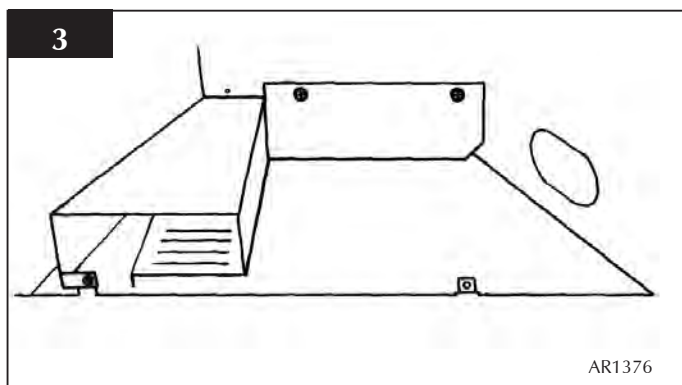

Then remove the two knockout holes on the rear of the box using a sharp hammer blow, Diagram 4.



- 5.4 Remove the backing from the self-adhesive silicone sealing strip and apply to the rear flange of the firebox ensuring that it is positioned as close to the outer edge as is practically possible, Diagram 5.

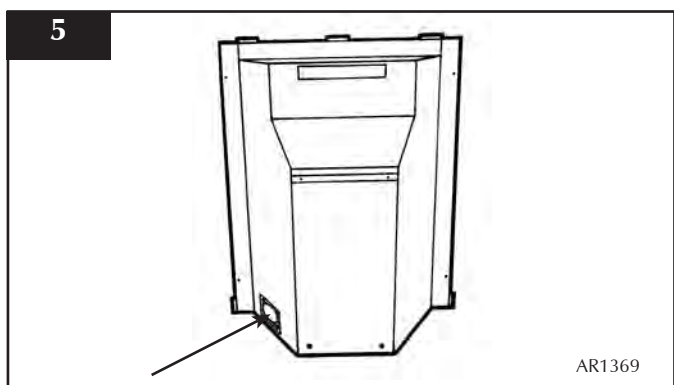

- 5.5 Gas pipe entry must come through the right-hand side of the box. The rubber seal must be cut using a sharp knife to allow the isolating elbow to pass through it. Ensure the rubber is not damaged when doing this.

A means of isolation is provided with the fire. This must be fitted to the supply pipe prior to installing the firebox.

6. INSTALLATION OF THE FIRE

- 6.1 Ensure that the fireplace opening is in compliance with Section 2 Site Requirements then proceed as follows:

A) CABLE RETENTION METHOD

- 6.2 Mark the position of the 4 fixing holes on the rear of the fireplace opening and drill the holes using a 6.5mm masonry drill bit. Insert the 4 fibre rawl plugs and screw the eyebolts in as far as possible leaving the eye horizontal, Diagram 6.

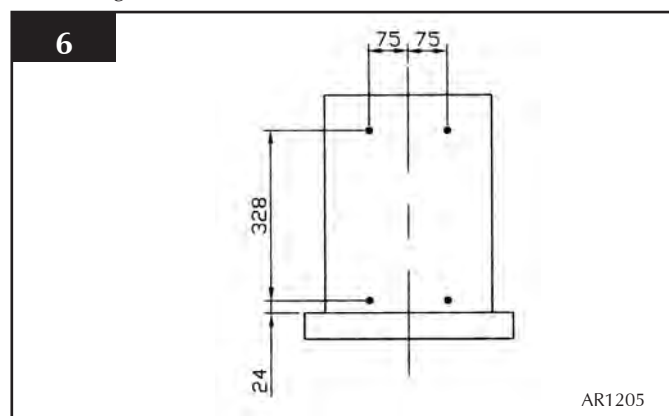

- 6.3 Pass the 2 cables through the holes in the bracket on the back of the firebox and pull taut so that the stop ends sit tightly against the top of the bracket, Diagram 7

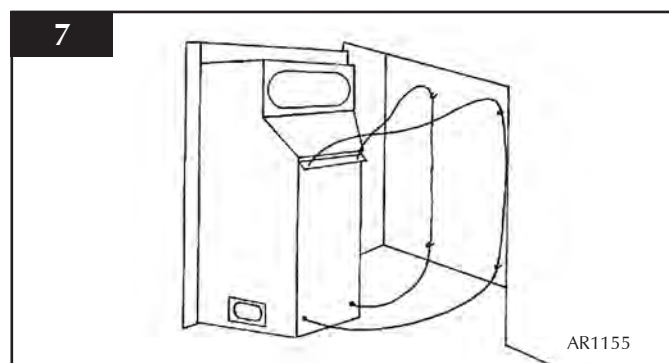

- 6.4 Pass the cables vertically through the 2 sets of eyebolts and thread the ends through the holes in the lower back of the firebox. Pass the gas supply pipe through the hole in the rubber seal (refer to section 5.5) and push the fire into place.
- 6.5 Thread the cables through the tensioner bolts and push the threaded portions through the holes in the firebox so that the lock nut sits against the back wall (ensure that the nut is screwed fully up to the head of the tensioner to allow maximum adjustment).
- 6.6 Slide the locking nipples onto the cables, pull the cables taut and tighten the locking screw. Adjust the lock nuts using a 10mm spanner until the silicone sealing strip forms a tight seal between the fireplace opening and the firebox flange, Diagram 8

INSTALLATION INSTRUCTIONS

INSTALLATION

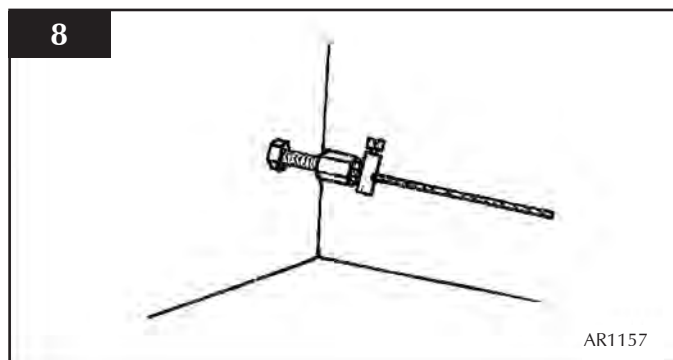

6.7 Coil up the surplus cable and locate in the back of the firebox.

NEVER SHORTEN THE CABLES, THEY WILL BE REQUIRED WHEN SERVICING THE APPLIANCE.

6.8 Replace the lower cover plate.
Note: The cable adjuster may need to be tucked upward in order to fit the lower cover plate.

B) SCREW FIXING METHOD

6.9 Alternatively, this appliance can be secured back to the fireplace opening using the screws and rawl plugs provided. Place the firebox centrally in the opening and mark the positions of the 4 fixing holes. Drill the holes and insert the 4 rawl plugs. See diagram 9

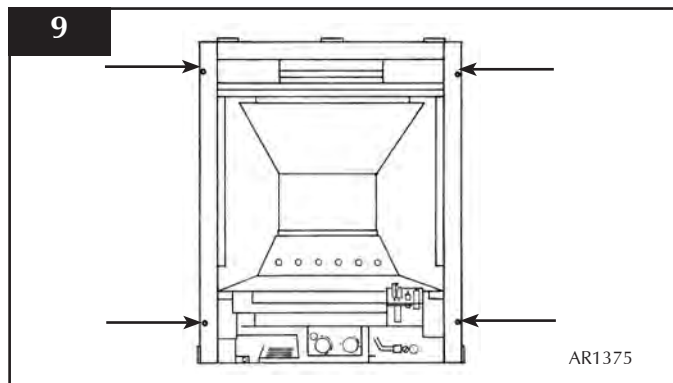

6.10 Offer the firebox into the opening and ensure that the gas supply pipe passes through the rubber seal.

6.11 Refit the burner assembly and secure the 5 pozidrive screws. Connect the gas supply to the inlet connection on the burner unit and tighten. It may be necessary to support the inlet connection with another spanner whilst tightening this joint. See diagram 10.

6.12 Turn on the gas supply to the appliance and check for leaks. Light the fire and check all joints on the appliance for leaks.

6.13 Remove the sealing screw from the inlet connection and connect a suitable "U" gauge manometer. Light the fire and turn to the maximum position, refer to the data badge and ensure that the running pressure is correct. If the pressure varies significantly from that on the data badge, this may indicate a supply problem and will require immediate attention.

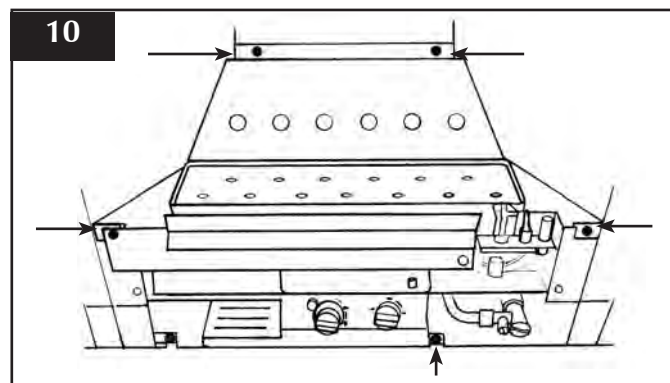

6.14 Turn the appliance off, disconnect the "U" gauge and replace the sealing screw. Relight the appliance and check the sealing screw for leaks.

7. FITTING THE DECORATIVE INNER PANEL

7.1 By rotating the panel, insert into fire box, Diagram 11.

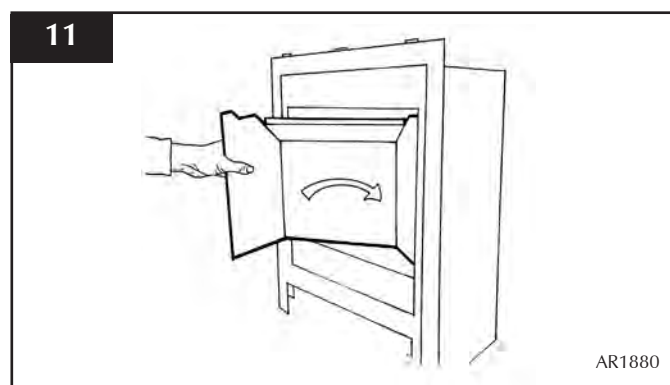

7.2 Check that the panel is sitting behind the rear ledge, but in front of the spacer bracket so that it locates in the slot, Diagram 12.

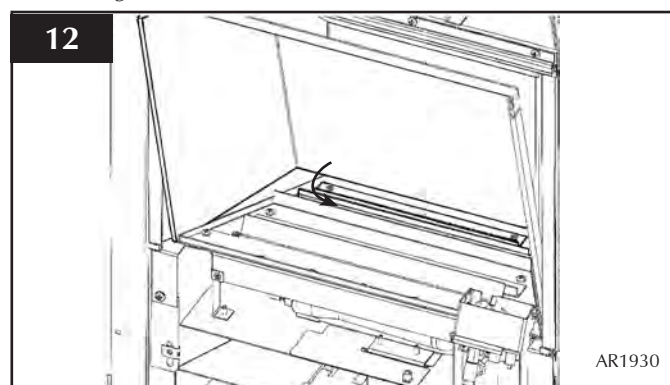

7.3 Secure the panel using the two upper brackets and the pozidrive screws, Diagram 13. Use only the rearmost hole in the retaining bracket on each side.

INSTALLATION INSTRUCTIONS

INSTALLATION

NOTE: IT IS IMPORTANT TO ENSURE THAT THE PANEL LOCATES TIGHTLY AGAINST THE BURNER TRAY.

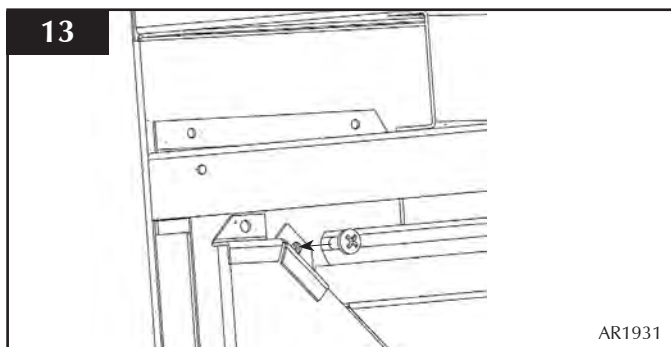

8. E-STUDIO ARRANGEMENT OF FUEL BED COMPONENTS

ONLY USE THE CORRECT TYPE AND QUANTITY OF GRANITE CHIPPINGS. ALWAYS FOLLOW THE FUEL BED LAYOUT AS STATED IN THESE INSTRUCTIONS. NEVER CHANGE THE LAYOUT FROM THAT SHOWN HERE.

- 8.1 Arrange the granite chippings in the areas highlighted in Diagram 14. Granite chippings should be evenly distributed.

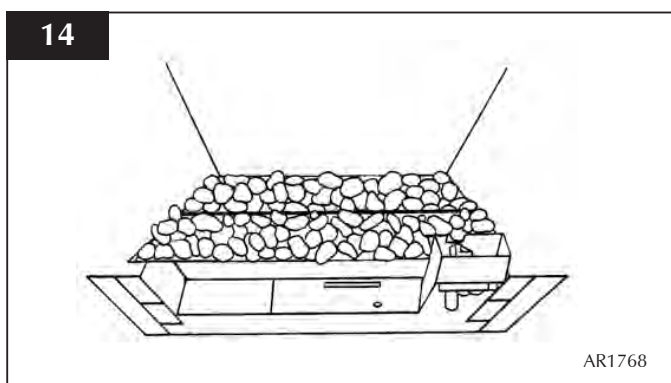

- 8.2 Lean the granite chippings against the burner ledges to disguise the ledges.

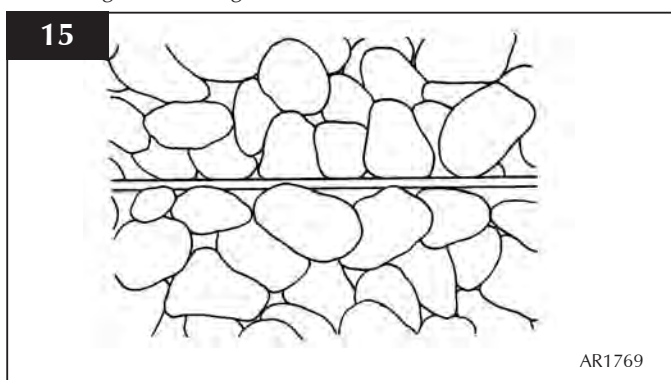

- 8.3 Check that the port area. Arrow A, is clear of granite chippings. This can be easily done by gently running a screwdriver or similar object along this area. Diagram 16.

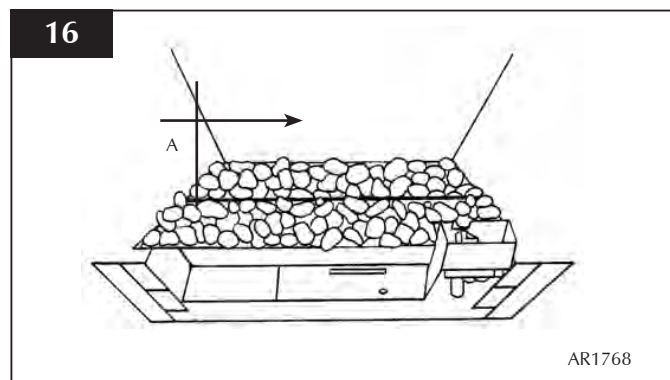

NOTE: IT IS IMPORTANT THE GRANITE CHIPPINGS DO NOT COVER THE PORT AREA IN BETWEEN THE BURNER LEDGES.

- 8.4 Ensure that no pebbles over-hang or fill the pilot area, Arrow C, Diagram 17.

NOTE: CHIPPINGS SHOULD NOT BE PLACED DIRECTLY IN FRONT OF THE PILOT CROSS LIGHTING FLAME.

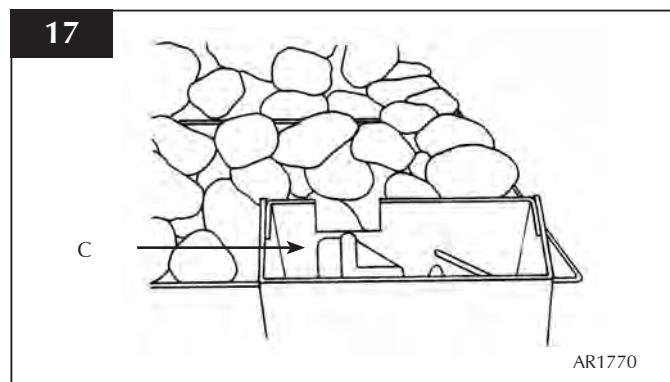

- 8.5 Ensure that the fibre glass window seal on the box is intact, then lower the glass window into the hooks on the box. Secure the window using four screws in the retaining bracket. See diagram 18.

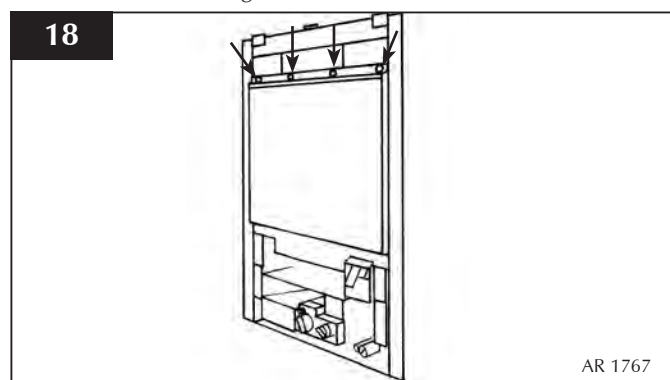

INSTALLATION INSTRUCTIONS

INSTALLATION

9. LOGIC E-BOX ARRANGEMENT OF FUEL BED COMPONENTS

ADVICE ON HANDLING AND DISPOSAL OF FIRE CERAMICS

The fuel effect and side panels in this fire are made from Refractory Ceramic Fibre (RCF), a material which is commonly used for this application.

Preventive clothing is not required when handling these articles, but we recommend you follow normal hygiene rules of not smoking, eating or drinking in the work area, and always wash your hands before eating or drinking.

To ensure that the release of RCF fibres is kept to a minimum during installation and servicing, a HEPA filtered vacuum is recommended to remove any dust accumulated in and around the fire before and after working on it.

When servicing the fire it is recommended that the replaced items are not broken up, but are sealed within heavy duty polythene bags and labelled as RCF waste.

RCF waste is classed as stable, nonreactive hazardous waste, and may be disposed of at a licensed landfill site.

Excessive exposure to these materials may cause temporary irritation to eyes, skin and respiratory tract; wash hands thoroughly after handling the material.

NOTE: CERAMIC PARTS ARE FRAGILE. THE SIDE AND REAR PANELS ARE REVERSIBLE. ONE SIDE IS PLAIN, THE OTHER SIDE IS REEDED. ONLY USE THE CORRECT TYPE AND QUANTITY OF CERAMIC COMPONENTS. ALWAYS FOLLOW THE FUEL BED LAYOUT AS STATED IN THESE INSTRUCTIONS. NEVER CHANGE THE LAYOUT FROM THAT SHOWN HERE.

- 9.1 Position the burner cover gasket on the burner skin ensuring the holes align with the ports. Take care as the front left-hand hole is offset compared to the others, Diagram 19, arrow A.

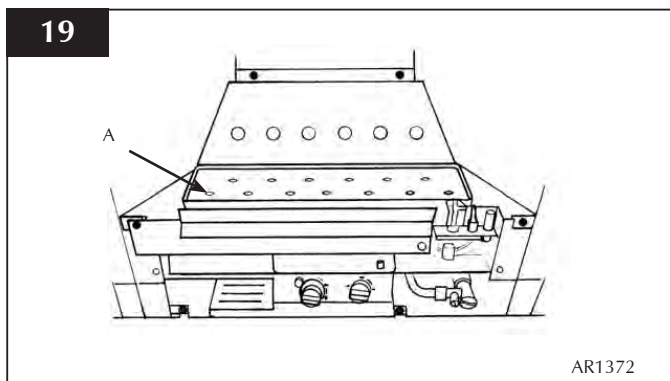

- 9.2 Place the rear panel against the rear of the box resting on the shelf. Then slide one of the side panels into the box

ensuring it touches the rear panel. Then gently ease the front edge of the side panel behind the flange so it lies flat against the wall of the box. Repeat with the second side panel., Diagram 20.

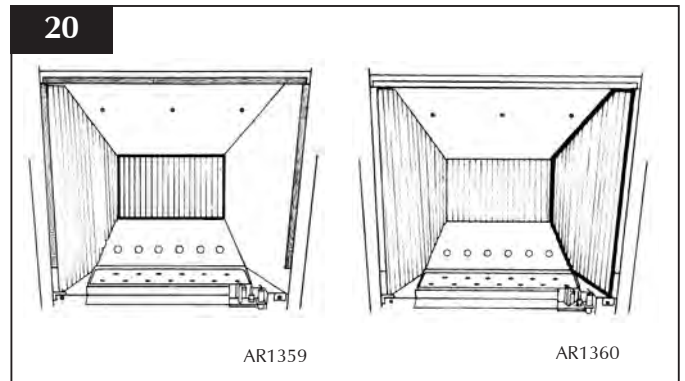

- 9.3 Locate the top panel on top of the sides and rear by lifting it up and forward inside the box. Then sliding it backwards and down behind the side panels and resting on the rear panel, Diagram 21.

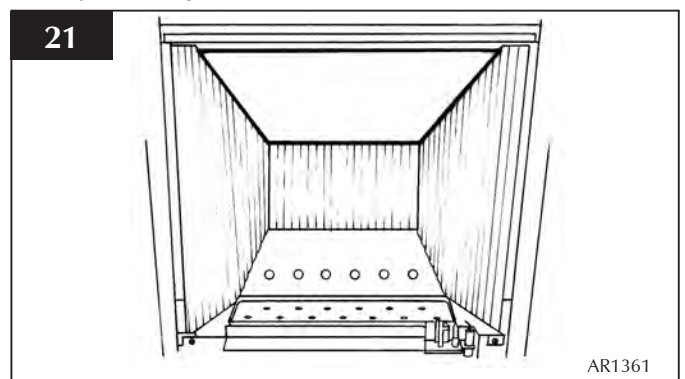

Coal Layout

- 9.4 Position the flame baffle centrally on the tray and ensure the stepped lower edge engages against the rear edge of the burner skin, Diagram 22.

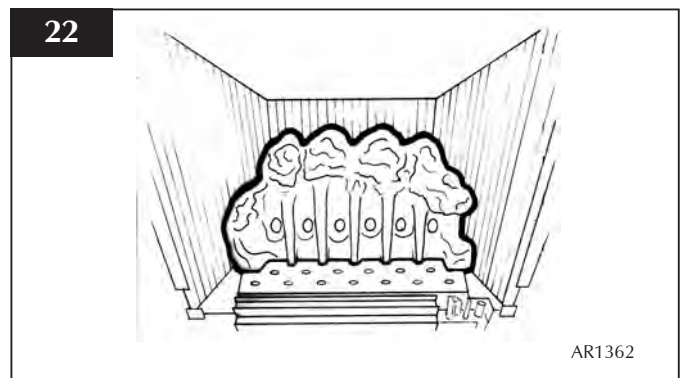

- 9.5 Place the front coal centrally in the channel at the front of the tray. See diagram 7. The relationship between the front coal and the flame baffle is shown in diagram 23.

INSTALLATION INSTRUCTIONS

INSTALLATION

23



AR1363

9.6 There are three sizes of coal used. Small, medium and large, Diagram 24 for identification.

24

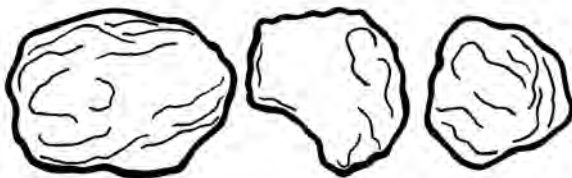

LARGE

MEDIUM

SMALL

AR1379

9.7 Place the single large coal in the depression in centre of the front coal resting against the flame baffle., Diagram 25.

25



AR1364

9.8 Place a medium size coal either side of the first large one, in the depressions in the front coal. Resting between the flame baffle and the front coal. See diagram 26.

26

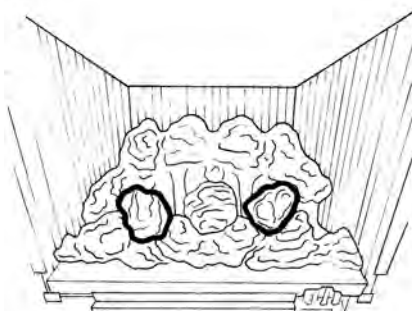

AR1365

9.9 Place another two medium size coals resting behind the first three coals and against the flame baffle, Diagram 27.

27

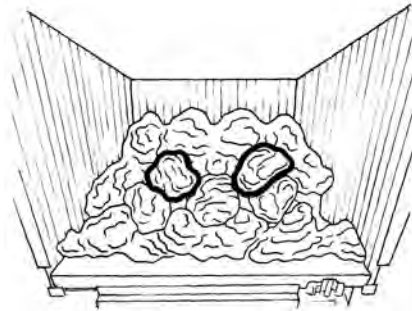

AR1366

9.10 Place a small coal directly behind the first large coal, and in between the centre of the last two medium coals resting on the flame baffle, Diagram 28.

28

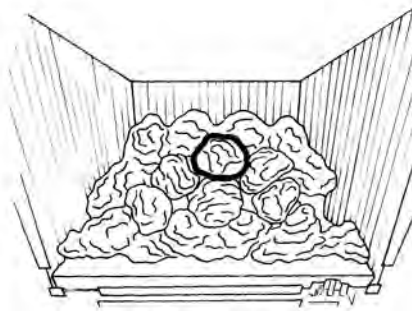

AR1367

9.11 Place two small coals to the left and right-hand side of the bed in the two spaces left. See Diagram 29.

29

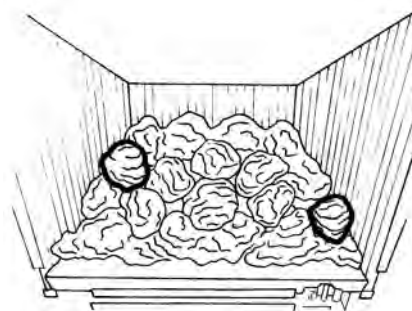

AR1368

INSTALLATION INSTRUCTIONS

INSTALLATION

Pebble Layout

- 9.12 Position the pebble flame baffle centrally on the tray and ensure the stepped lower edge engages against the rear edge of the burner skin, Diagram 30

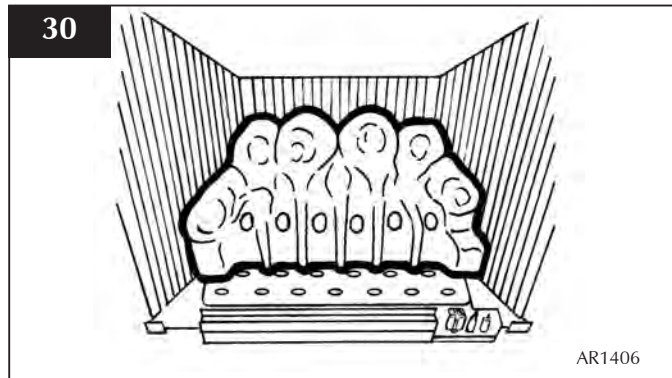

- 9.13 Place the front pebble piece centrally in the channel at the front of the tray, Diagram 31.

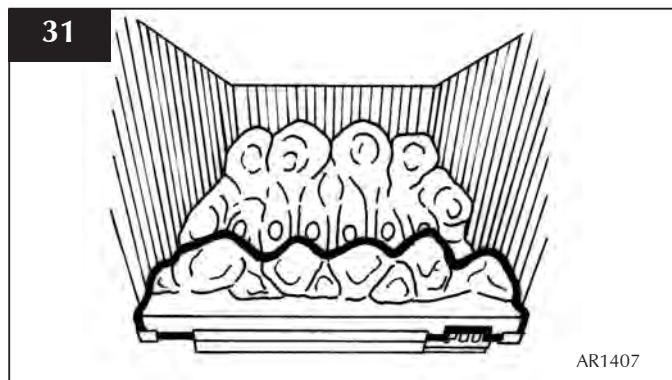

- 9.14 Place the four pebbles as identified resting between the front ceramic and the flame baffle as shown in diagram 32.

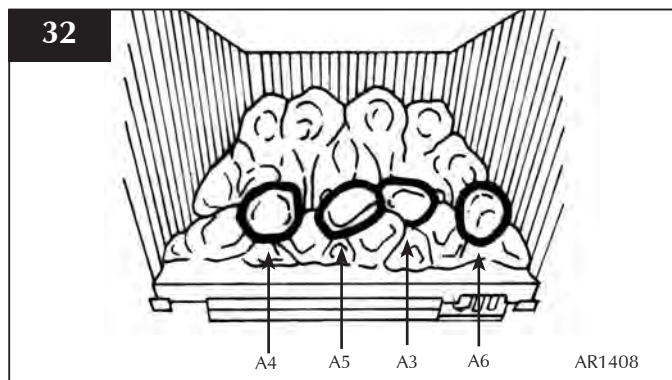

- 9.15 Place the next four pebbles as identified resting between the flame baffle and the first row of pebbles as shown in diagram 33.

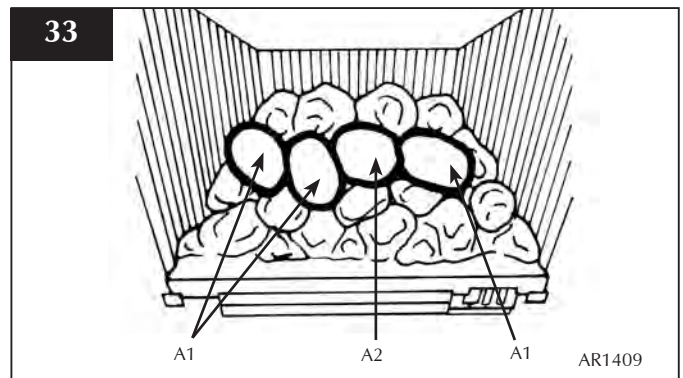

- 9.16 Place the remaining two pebbles identified as shown in diagram 34.

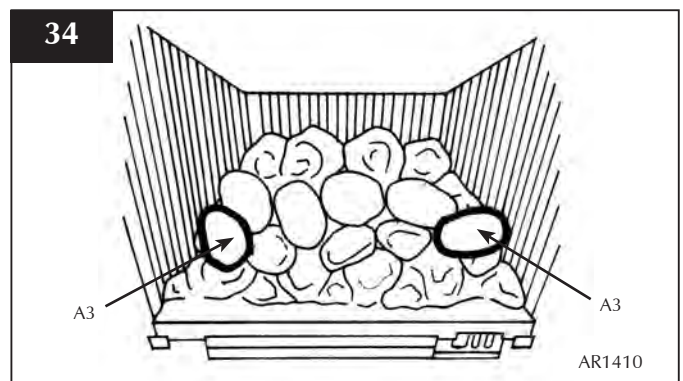

- 9.17 The coals/pebbles should evenly cover the whole bed with the gaps between them kept equal. This will maximise the performance of the product

- 9.18 ENSURE THAT THE COALS/PEBBLES ARE POSITIONED AS ABOVE. ONLY USE THE CORRECT AMOUNT OF COALS/PEBBLES AS SPECIFIED IN THE DIAGRAMS.

- 9.19 Ensure that the fibre glass window seal on the box is intact, then lower the glass window into the hooks on the box. Secure the window using four screws in the retaining bracket. See diagram 35.

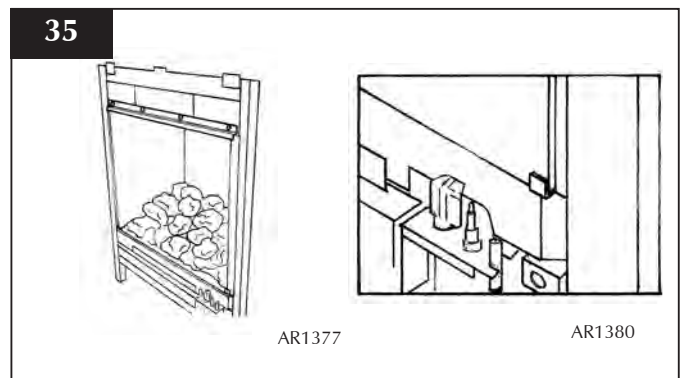

NEVER OPERATE THE FIRE WHEN THE GLASS PANEL IS REMOVED OR BROKEN

INSTALLATION INSTRUCTIONS

INSTALLATION / COMMISSIONING

10. LIGHTING THE FIRE

- 10.1 Locate the control valve on the fire. There are two control knobs on the valve, the right-hand knob controls the pilot ignition and the left hand knob controls the main burner.
- 10.2 If your fire has already been upgraded to battery remote control, please refer to the instructions provided with the upgrade to operate the remote control. The following instructions will work for either situation.

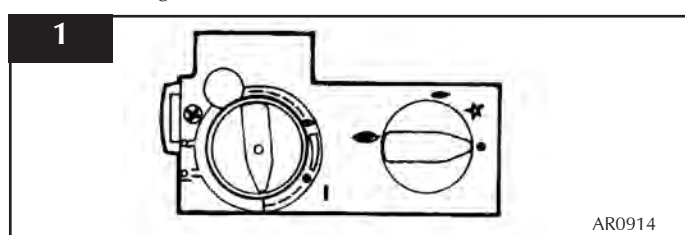

- 10.3 Ensure that the left-hand control knob is pointing to off (●).
- 10.4 Ensure that the right-hand control knob is pointing to off (●).
- 10.5 Press in the right-hand control knob and rotate it anti-clockwise until a click is heard (keep pressing in) and the knob is pointing to pilot (☞). The pilot should now light.
If the pilot has not lit, repeat the procedure until it does.
- 10.6 Keep the control knob pressed for 10 seconds and then release it, the pilot should stay alight. If the pilot goes out, repeat the procedures until it does.
- 10.7 If the pilot will not light after repeated attempts, contact the retailer or installer from whom the fire was purchased.
- 10.8 Turn the right-hand control to point to main burner (☞). The fire can now be controlled using the left hand control knob.
- 10.9 Turn the left hand control knob to point to low fire (☞), the main burner will light on low. The burner can now be controlled between low and high settings. Turn the control knob anti clockwise increase the flame height and clockwise to decrease the flame height.

THE YELLOW FLAMES WILL APPEAR WHEN THE FIRE HAS GAINED SUFFICIENT HEAT - TYPICALLY 10 TO 20 MINUTES.

IF THE PILOT FLAME IS EXTINGUISHED, INTENTIONALLY OR UNINTENTIONALLY, DO NOT RELIGHT THE APPLIANCE FOR AT LEAST 3 MINUTES.

1. COMMISSIONING

- 1.1 Close all windows and doors to the room, check all controls, and allow fire to burn on maximum for 5 minutes. Test for spillage of flue products using a smoke match. Pass the lighted smoke match along the top front of the draught diverter, just inside. See diagram 1.

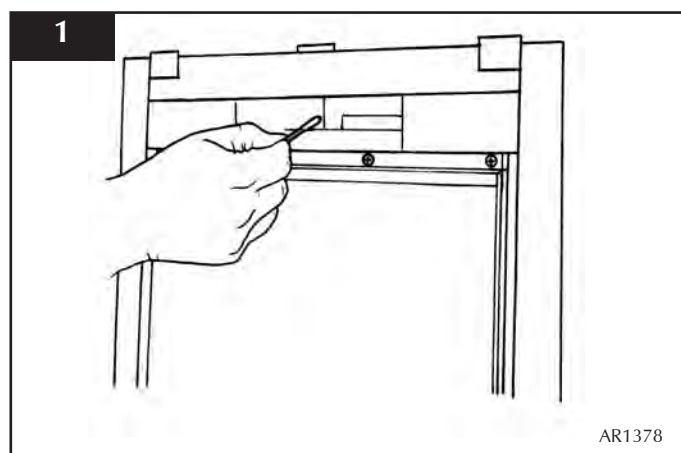

- 1.2 If the fire spills, run for a further 10 minutes and re-check.
- 1.3 If there are extractor fans in the room or adjacent rooms, the spillage test must be repeated with the extractors running on maximum.

IF SPILLAGE PERSISTS, DISCONNECT THE FIRE AND SEEK EXPERT ADVICE.

For future reference record the installation details on the commissioning sheet on page 3 of these instructions.

SERVICING INSTRUCTIONS

SERVICING

1. SERVICING REQUIREMENTS

This fire must be serviced at least once a year by a competent person.

All tests must be serviced by best practice as described by the current CORGI recommendations.

- 1.1 Before any tests are undertaken on the fire, conduct a gas soundness test for the property to ensure that there are no gas leaks prior to starting work.
- 1.2 Before any tests are undertaken on the fire it is also recommended to fully check the operation of the fire.
- 1.3 Special checks
 - 1.3.1 Clean any lint or fluff from the pilot - pay particular attention to the aeration hole in the side of the pilot.
 - 1.3.2 Clean away any fluff or lint from under the burner
 - 1.3.3 Check that the spark gap on the pilot is correct.
- 1.4 Correct any faults found during the initial tests and then recommission the fire conducting the usual safety checks.
- 1.5 Advise the customer of any remedial action taken.
- 1.6 As part of the annual service, the space behind the firebox must be inspected for any debris, which may have fallen down the chimney.
- 1.7 To remove the fire from the firebox first remove the decorative frame. There are two screws securing the frame to the fire. Refer to separate frame instructions.
- 1.8 Turn off the gas supply at the isolation device located under the fire.
- 1.9 Disconnect the gas supply pipe leaving the isolation device on the supply pipe and not the fire.
- 1.10 Remove the glass window by removing the four screws in the retaining bracket, Diagram 1.

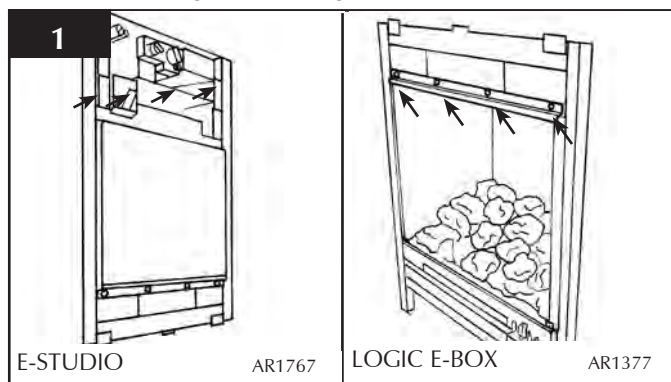

LOGIC E-BOX

- 1.11 Remove the loose coals, and place on a dry, clean surface.
- 1.12 Remove the front coal, flame baffle and all the ceramic liners. All these items are very fragile so store them carefully.

- 1.13 Remove the five screws securing the burner unit to the fire and lift clear. See diagram 2

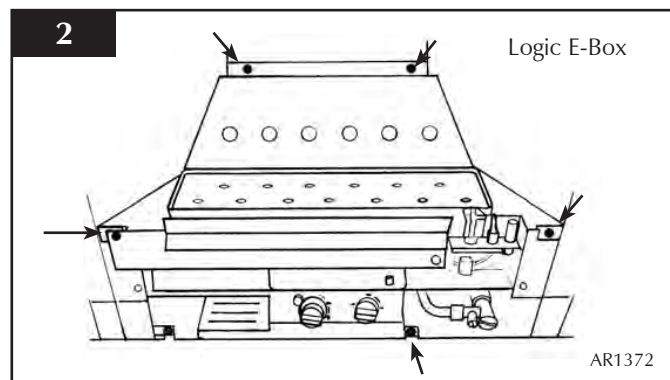

E-STUDIO

- 1.14 Remove the five screws securing the burner unit. Gently slide the whole burner assembly forward. Gently empty the granite chippings onto a dry clean surface. Clean any debris from the burner skin.

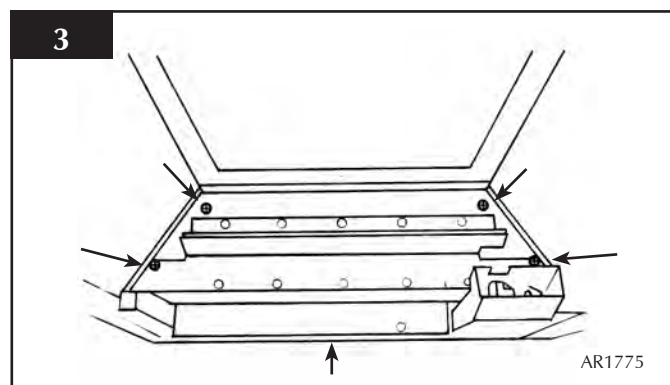

- 1.15 Remove the two decorative panel securing clamps, Diagram 4

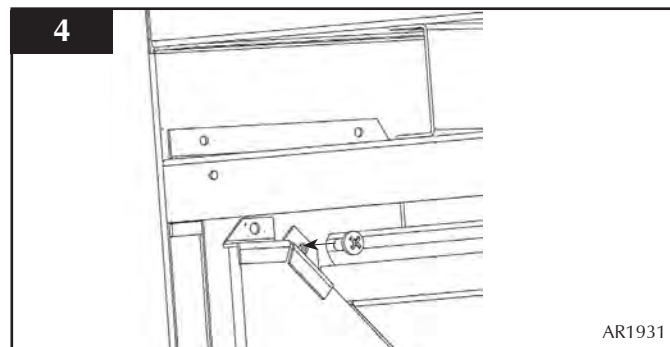

SERVICING INSTRUCTIONS

SERVICING

- 1.16 Carefully remove the enamel back panel by rotating it out of the fire box.

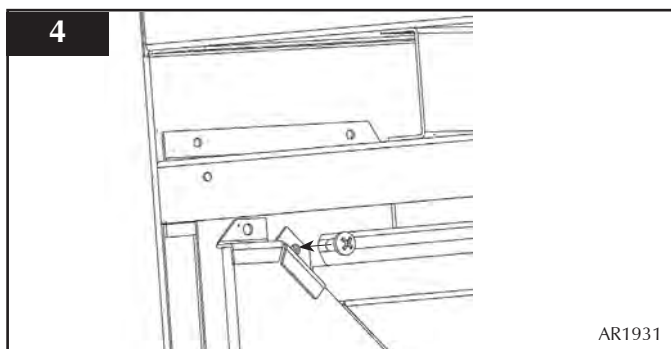

TAKE EXTREME CARE WHILST REMOVING THESE PANELS NOT TO SCRATCH OR CHIP THE PANEL ON THE SIDES OF THE FIREBOX.

E-STUDIO & LOGIC E-BOX

- 1.17 Depending on the method of how the fire is secured to the fire place either:

- 1) Remove the three screws securing the cover plate, then release the retention cables. See diagram 6.
- 2) Remove the four screws securing the fire to the fireplace.

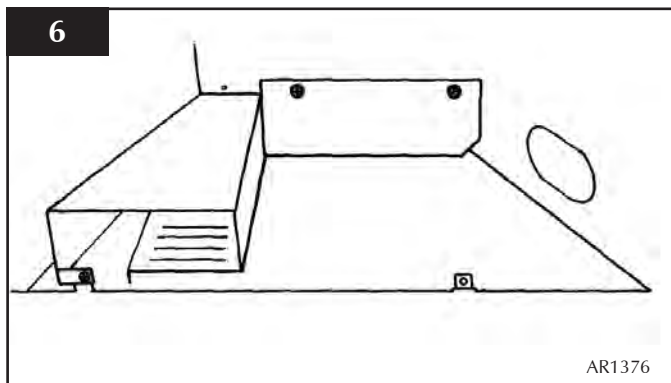

- 1.18 Inspect the space behind the fireplace for debris and the condition of the chimney, the flue flow test should be carried out now. Remove any debris and carry out any necessary remedial work.

SERVICING INSTRUCTIONS

FAULT FINDING CHARTS

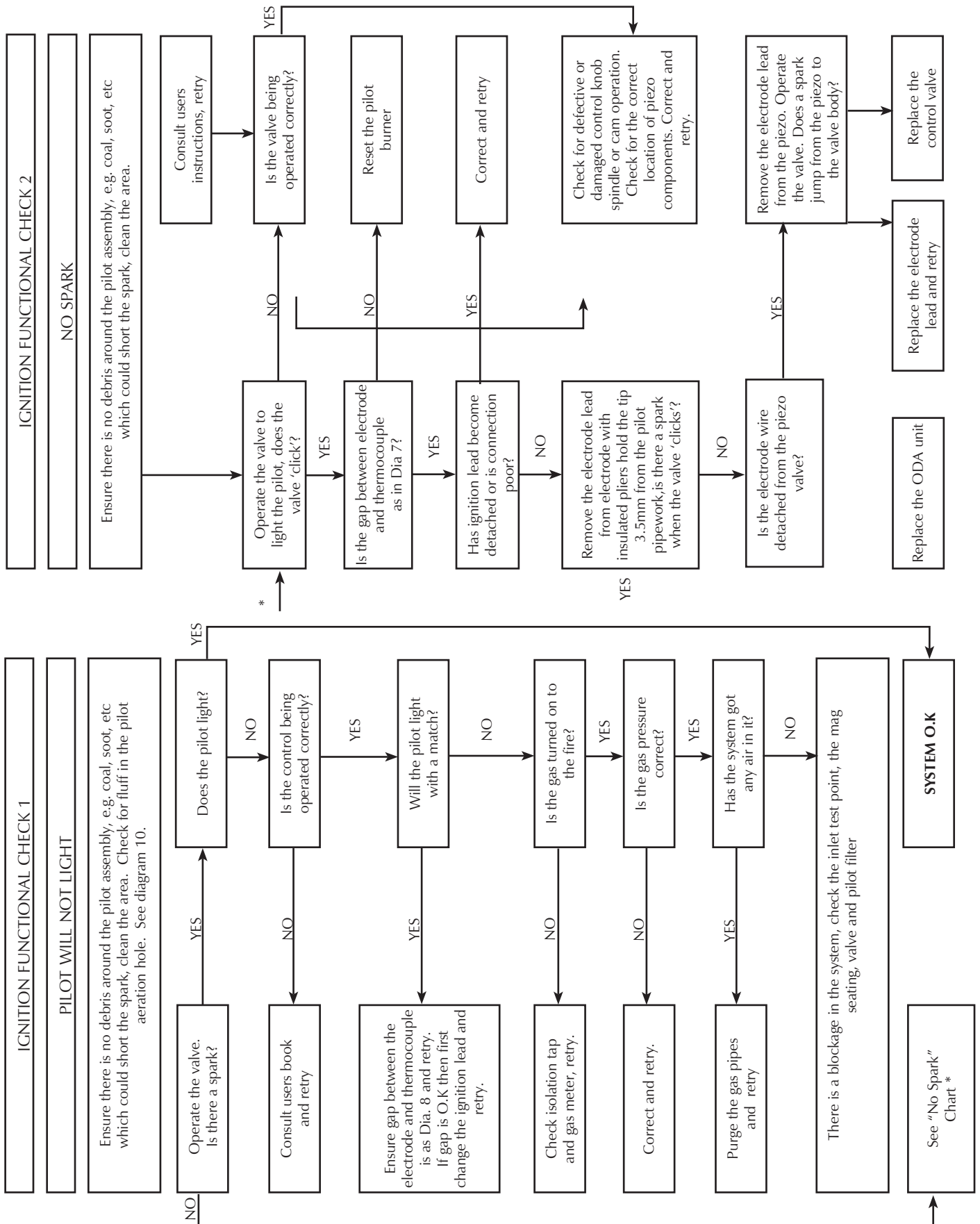

SERVICING INSTRUCTIONS

FAULT FINDING CHARTS

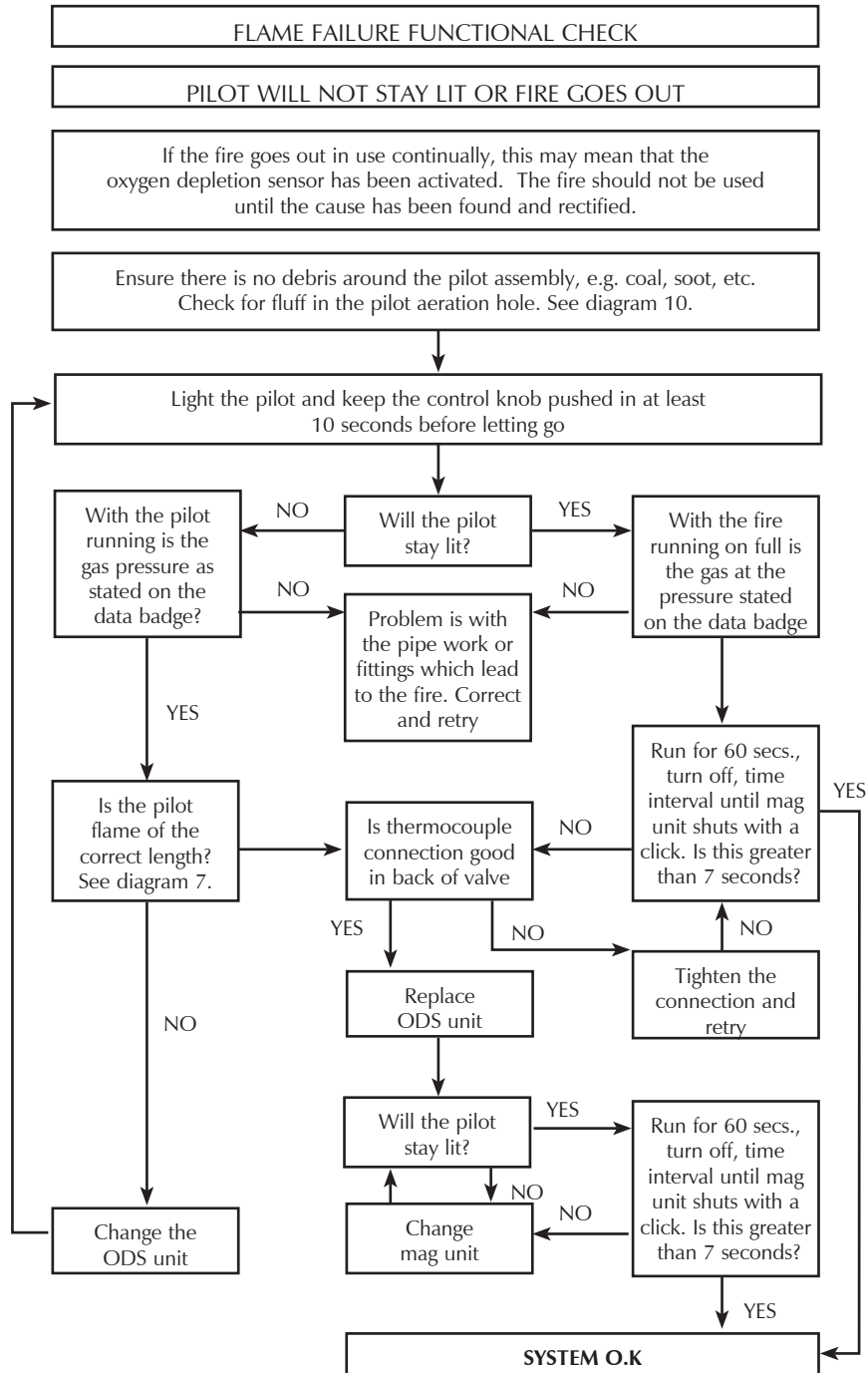

SERVICING INSTRUCTIONS

REPLACING PARTS

1. GENERAL

- 1.1 To service any of the following parts of the fire, it will be necessary to remove the burner unit from the firebox. To remove the burner refer to previous section **SERVICING**.
- 1.2 The heat shield will need to be removed from the burner for servicing. To do this remove the five screws indicated in diagram 1 and slide the shield forward. Note: E-Studio only has three screws.

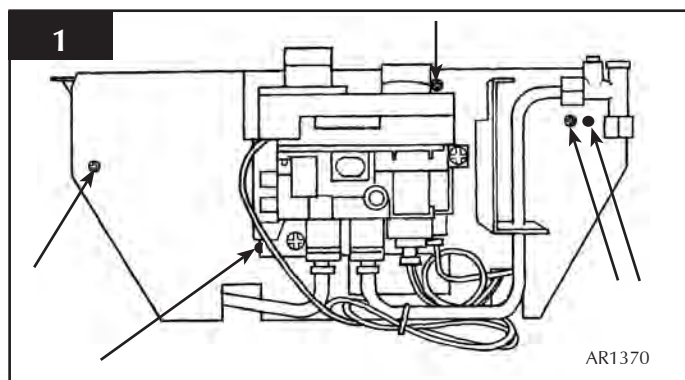

2. IGNITION LEAD

- 2.1 Undo the single screw that secures the left hand side of the control cover, Diagram 2.

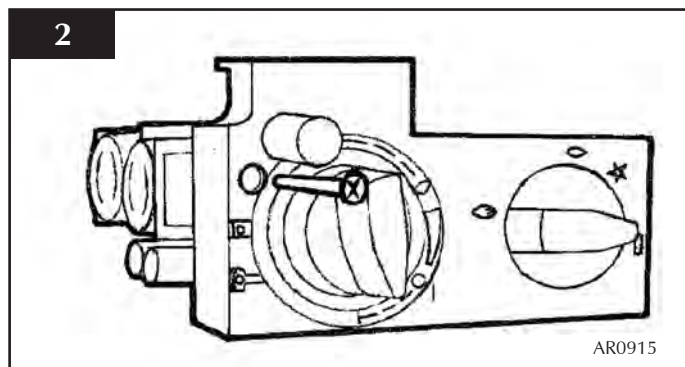

- 2.2 To release the right-hand side of the control cover insert the narrow blade screwdriver into the slot shown in diagram 3, lever it gently and pull from the right-hand side at the same time. The cover will now come off, there is a small cylindrical metal spacer inside the cover, this must be kept and replaced on the fixing screw during re-assembly.

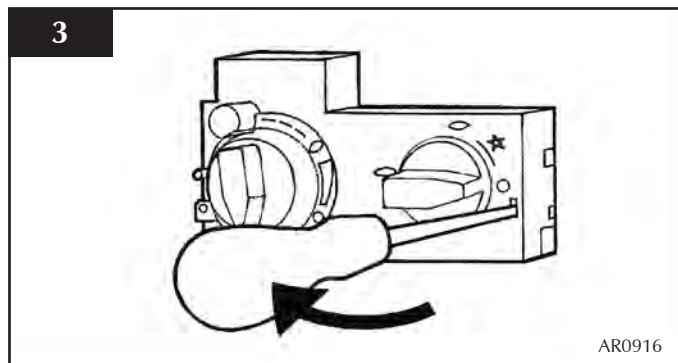

- 2.3 Disconnect the ignition lead from the gas valve and the pilot, Diagram 4 arrow A.

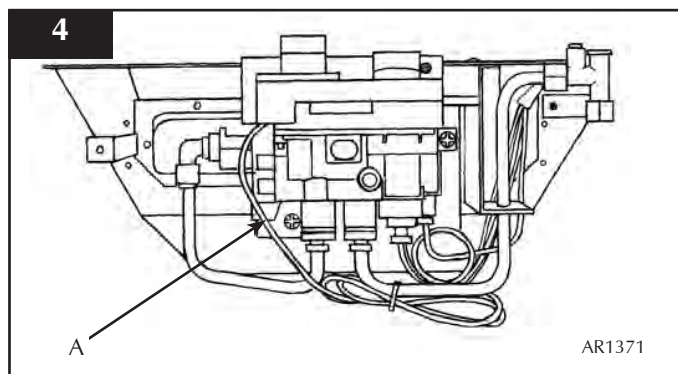

- 2.4 Replace with a new ignition lead following the same route as the old one. Replace the valve cover and refit the burner.
- 2.5 Check the operation of the new ignition lead.
- 2.6 Replace the fire frame.

3. PIEZO

- 3.1 The piezo assembly used on this fire is not serviceable and is unlikely to fail. If a new piezo is required it will be necessary to change the gas valve, refer to section 5.

SERVICING INSTRUCTIONS

REPLACING PARTS

4. ODS PILOT UNIT

Note: You cannot service the pilot unit due to the complex nature of its manufacture. Replacement of the complete unit must be carried out when one of the following items becomes faulty:

- Pilot injector
- Ignition electrode
- Thermocouple

4.1 Access to the E-Studio pilot unit differs from the Logic E-box. Follow the relevant instruction for your fire.

E-STUDIO

4.2 Gently pull the ignition lead off the electrode, Arrow A and undo the screw shown at Arrow B, Diagram 5.

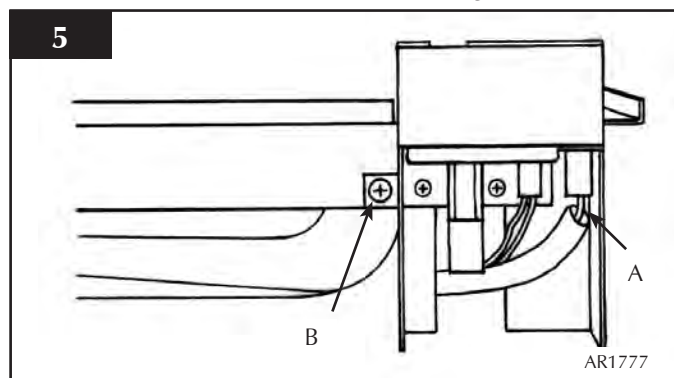

4.3 Lift the shroud up and away from the pilot.

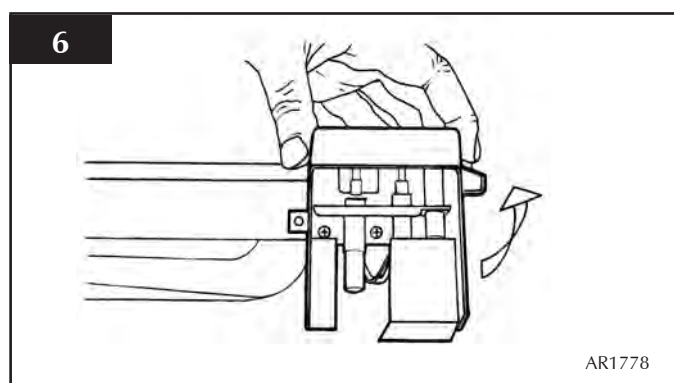

4.4 Remove the two screws securing the pilot assembly. Diagram 7, Arrow C.

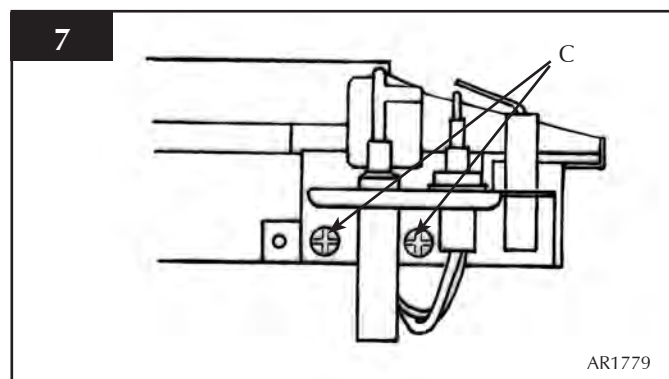

LOGIC E-BOX

4.5 Gently pull the ignition lead off the electrode, Diagram 8, Arrow A.

4.6 Remove the two screws securing the pilot assembly, Diagram 8 Arrow B.

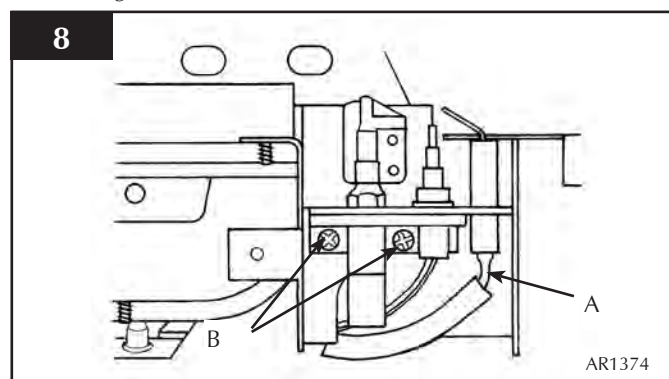

E-STUDIO & LOGIC E-BOX

4.7 Undo the thermocouple connection at the back of the gas valve and the pilot pipe at the pilot elbow, Diagram 9 Arrows B and C.

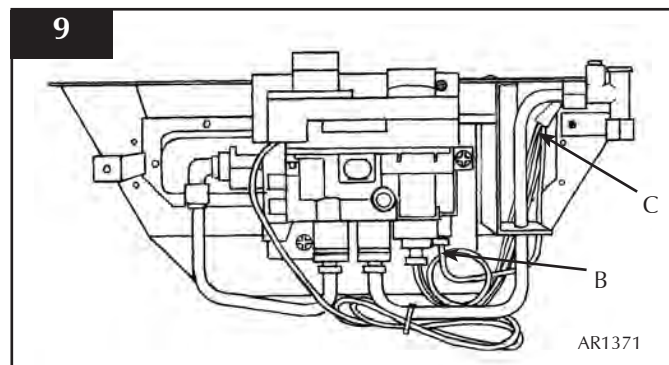

SERVICING INSTRUCTIONS

REPLACING PARTS

- 4.8 Replace with a new pilot assembly and check the spark gap, Diagram 10.

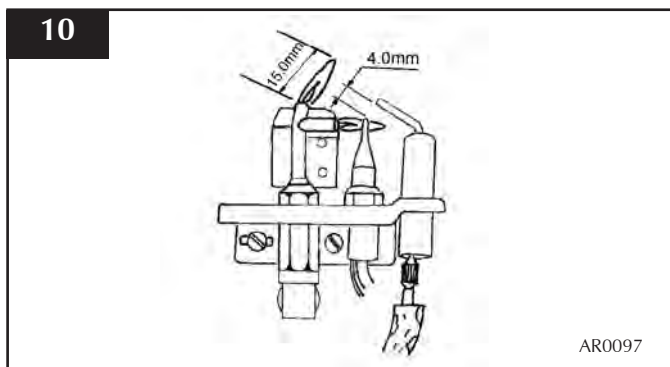

- 4.9 After reassembly, check for gas soundness and carry out a flame failure functional check as detailed in the flow chart, especially the mag drop out time.

5. GAS VALVE

- 5.1 Disconnect the 2x8mm and 1x4mm gas pipe fittings at the back of the gas valve and also disconnect the thermocouple, Diagram 11 arrows B and E.

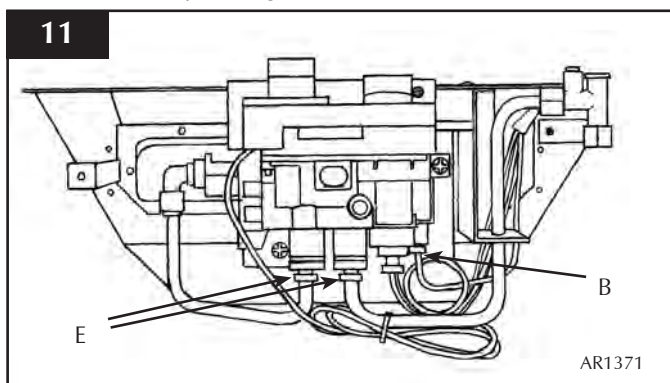

- 5.2 Disconnect the injector nut, Diagram 12 arrow D.

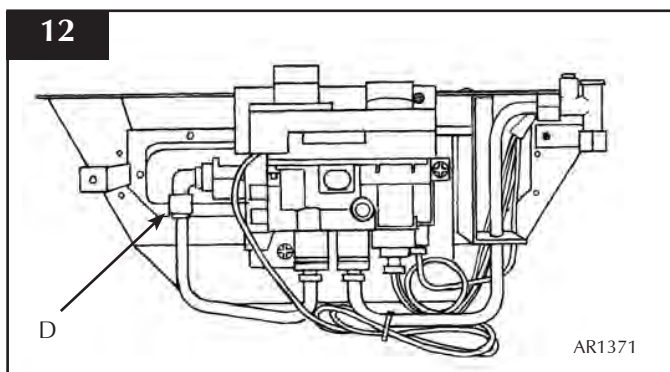

- 5.3 Undo the two bolts securing the gas valve to the fire and remove the valve.
5.4 Replace in reverse order.
5.5 Check all joints for gas leaks, check operation of the thermocouple and ignition lead.

6. MAG UNIT

- 6.1 Remove the fire, refer to section 1.
6.2 Undo the thermocouple nut. Diagram 13 arrow B.

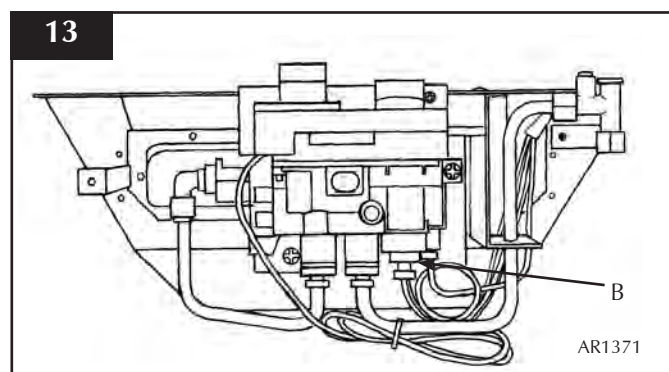

- 6.3 Undo the mag unit retaining nut at the back of the control valve behind the thermocouple nut.
6.4 After removing the retaining nut, the mag unit can be tapped out and a replacement fitted.
6.5 Replace the mag unit retaining nut and tighten. Note - this is a gas-tight seal.
6.6 Replace the thermocouple and check for gas leaks.
6.7 After reassembly, carry out the flame failure functional check as detailed in the flow chart, especially the mag unit drop out time.

7. MAIN INJECTOR

- 7.1 Undo the injector compression nut and valve nut, Diagram 14 arrows D and E, pull the pipe clear of the injector body.

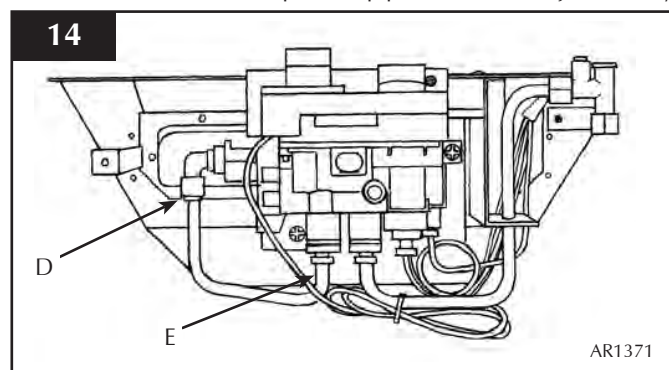

SERVICING INSTRUCTIONS

REPLACING PARTS

- 7.2 Rotate the injector until it is fully removed.
- 7.3 Replace with the correct replacement injector. When ordering, always state the model, gas type and serial number.
- 7.4 Reassemble and turn the gas supply on, check for any leaks.

8. CHANGING BETWEEN GAS TYPES

E-Studio

The following parts must be changed when converting an E-Studio from one gas type to another:

Burner Assembly	NG	GZ6197
	LPG	GZ6198
Data badge	PR0393EB	

Logic E-Box

The following parts must be changed when converting a Logic E-Box from one gas type to another:

		COAL	PEBBLE
Burner assembly	NG	A8691	A8691PB
	LPG	AP8691	AP8691PB
Data badge		PR0393EB	
Burner Cover Gasket	NG	CE0273	
	LPG	CE0498	

Both E-Studio & Logic E-Box

Note: The control valve will be set for the particular fire and gas type. In all instances, when ordering new parts, be sure to quote the fire type and serial number.

Use only genuine Gazco replacement parts. Nonstandard components will invalidate the guarantee and may be dangerous.

9. SPARE PARTS LIST-E-STUDIO

GENERAL	
ENAMEL PANEL	GZ6550
GRANITE CHIPPINGS	CE0547
NATURAL GAS PARTS	
MAIN INJECTOR	IN0044
PILOT ASSEMBLY	PI0036
AERATION PLATE (NG)	GZ3270
GAS VALVE	GC0088

LPG PARTS	
MAIN INJECTOR	IN0065
PILOT ASSEMBLY	PI0037
AERATION PLATE (LPG)	GZ3270
GAS VALVE	GC0088
MISCELLANEOUS	
IGNITION LEAD	GC0090
MAG UNIT	GC0092
CONTROL COVER	GC0087
UPGRADE KIT STANDARD	8455
UPGRADE KIT THERMOSTATIC	8456
PILOT SHROUD	GZ6370

10. SPARE PARTS LIST - LOGIC E-BOX

CERAMIC PARTS	COAL	PEBBLE
FRONT COAL/PEBBLE	CE0490	CE0502
FLAME BAFFLE	CE0491	CE0503
SIDE PANEL LH	CE0482	CE0515
SIDE PANEL RH	CE0483	CE0514
REAR PANEL	CE0497	CE0517
TOP PANEL	CE0484	CE0516
COALS AND PEBBLES	CE0496	CE0504
NATURAL GAS PARTS		
MAIN INJECTOR	IN0064	
PILOT ASSEMBLY	PI0036	
AERATION PLATE (NG)	GZ3269	GZ3866
BURNER COVER BASKET (NG)	CEO273	
GAS VALVE	GC0088	
LPG PARTS		
MAIN INJECTOR	IN0031	
PILOT ASSEMBLY	PI0037	
AERATION PLATE (LPG)	GZ3866	GZ2025
GAS VALVE	CE0498	
UPGRADE KIT THERMOSTATIC	GC0088	
MISCELLANEOUS		
IGNITION LEAD	GC0090	
MAG UNIT	GC0092	
CONTROL COVER	GC0087	
UPGRADE KIT STANDARD	8455	
UPGRADE KIT THERMOSTATIC	8456	

SERVICE RECORDS

1ST SERVICE

Date of Service:.....

Next Service Due:.....

Signed:.....

Dealer's Stamp/CORGI Registration Number

3RD SERVICE

Date of Service:.....

Next Service Due:.....

Signed:.....

Dealer's Stamp/CORGI Registration Number

5TH SERVICE

Date of Service:.....

Next Service Due:.....

Signed:.....

Dealer's Stamp/CORGI Registration Number

7TH SERVICE

Date of Service:.....

Next Service Due:.....

Signed:.....

Dealer's Stamp/CORGI Registration Number

9TH SERVICE

Date of Service:.....

Next Due:.....

Signed:.....

Dealer's Stamp/CORGI Registration Number

2ND SERVICE

Date of Service:.....

Next Service Due:.....

Signed:.....

Dealer's Stamp/CORGI Registration Number

4TH SERVICE

Date of Service:.....

Next Service Due:.....

Signed:.....

Dealer's Stamp/CORGI Registration Number

6TH SERVICE

Date of Service:.....

Next Service Due:.....

Signed:.....

Dealer's Stamp/CORGI Registration Number

8TH SERVICE

Date of Service:.....

Next Due:.....

Signed:.....

Dealer's Stamp/CORGI Registration Number

10TH SERVICE

Date of Service:.....

Next Service Due:.....

Signed:.....

Dealer's Stamp/CORGI Registration Number

Free Manuals Download Website

<http://myh66.com>

<http://usermanuals.us>

<http://www.somanuals.com>

<http://www.4manuals.cc>

<http://www.manual-lib.com>

<http://www.404manual.com>

<http://www.luxmanual.com>

<http://aubethermostatmanual.com>

Golf course search by state

<http://golfingnear.com>

Email search by domain

<http://emailbydomain.com>

Auto manuals search

<http://auto.somanuals.com>

TV manuals search

<http://tv.somanuals.com>