

# SHURE®

Shure Brothers Incorporated  
222 Hartrey Avenue  
Evanston IL 60202-3696 U.S.A.

## Models WM98 and SM98A User's Guide

### MODEL WM98 AND SM98A MINIATURE CONDENSER MICROPHONES



#### GENERAL

Shure Models WM98 and SM98A are miniature electret condenser microphones with a unidirectional (cardioid) pickup pattern. A smooth wide frequency response from 40 to 20,000 Hz makes the microphones well suited for musical instrument pickup. The WM98 is for wireless use; the SM98A is for wired applications. Both models feature the 98 microphone element.

The cardioid polar response of the 98 discriminates against sounds coming from the rear, permitting higher gain before feedback in sound reinforcement applications. With its true cardioid pattern extending to 20,000 Hz, the microphone can often be used for pickup of a particular instrument in an ensemble or orchestra.

When still stronger rejection of off-axis pickup is required, the A98SPM Supercardioid Polar Modifier should be used. This device changes the pickup pattern from cardioid to supercardioid with minimal change of on-axis microphone frequency response. With the A98SPM the 98 becomes the smallest multi-pattern microphone available, eliminating the need for costly multiple capsules. The A98SPM is supplied with the SM98A; it is an optional accessory for the WM98.

A very high maximum sound pressure level allows use of the 98 with all acoustic instruments including drum kits and other percussion as well as brass, reed, wind, string, and keyboard instruments. The 98 can also be used with amplified guitars and keyboards.

The WM98 can be connected directly to a Shure wireless transmitter using the supplied cable; other transmitters must be checked for proper pin configuration, condenser microphone power supply, and connector type.

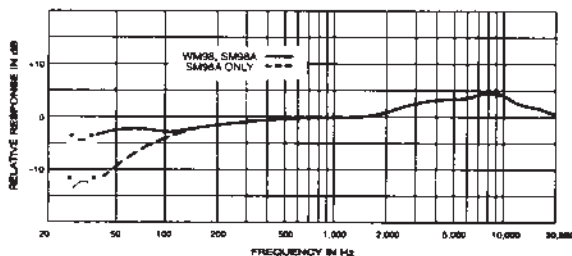

TYPICAL FREQUENCY RESPONSE  
FIGURE 1

The WM98 is supplied with a versatile shock-mount swivel adapter for mounting on a standard 5/8"-27 thread, a 1.12 m (3 ft 8 in.) cable with miniature 3- and 4-pin connectors (Switchcraft TA3 and TA4 types), and an acoustic foam windscreen to minimize wind noise in outdoor applications and from air-moving equipment.

The Shure ILP-1, low-distortion high-clipping-level, phantom-powered preamplifier, is furnished with the SM98A microphone. Additional included accessories are: a windscreen for use with the microphone alone, and a windscreen for use with the A98SPM, a shock-mount swivel adapter and a detachable 4.6 m (15 ft) cable with Switchcraft "Tini Q-G" connectors.

The ILP-1 preamplifier provides switchable gain of 0 or +10 dB and switch-selectable Flat or Low-Cut response to suit pickup for various instruments. The Low-Cut position is also useful to filter out low-frequency noise from such sources as wind noise or air conditioner or heater fans. The ILP-1 can be powered by any 11- to 52-volt dc phantom supply from sound reinforcement, recording, or broadcast equipment.

Optional accessories, designed exclusively for use with the WM98 and SM98A, are available. These include the following:

- A98MK Drum Kit, with gooseneck holder and clamp for mounting the microphone directly on most drums.
- A98KCS Horn Mount, a shock-mounted clamp designed especially for securely mounting the 98 on a horn, wind, or reed instrument.

#### Microphone Features:

- Smooth, wide frequency response for accurate sound reproduction across the entire audio spectrum
- Symmetrical cardioid pattern, uniform with frequency to 20 kHz
- Very high sound pressure level capability
- Very low distortion and high output clipping level
- Low susceptibility to RFI, electrostatic and electromagnetic hum
- Smallest multi-pattern microphone available – without the need for multiple capsules
- Rugged construction for outstanding reliability
- Cable detachable at both microphone and transmitter (WM98) or preamplifier (SM98A)
- Usable over very wide range of temperature and humidity
- Supplied with unique shock-mount swivel adapter for mounting on conventional microphone stands or goosenecks
- Optional accessories to increase microphone versatility

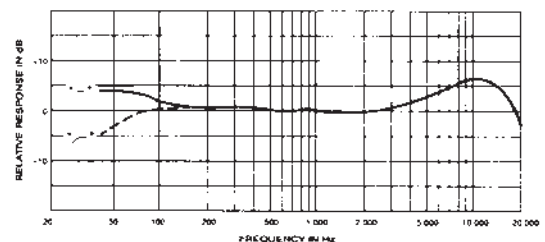

TYPICAL FREQUENCY RESPONSE – SM98A WITH  
A98SPM POLAR MODIFIER INSTALLED  
FIGURE 2

SPECIFICATIONS	WM98 MICROPHONE (with standard test circuit—Figure 6)	SM98A MICROPHONE
Type	Condenser (electret bias)	
Frequency Response (Figs. 1–2)	40 to 20,000 Hz	
Polar Pattern (Figs. 3–4)	Unidirectional (cardioid) or supercardioid with A98SPM Supercardioid Polar Modifier	
Output Impedance	1200 Ω	Rated at 150 Ω (90 Ω actual) Recommended minimum load impedance: . . . . . 800 Ω (May be used with loads as low as 150 Ω with reduced clipping level)
Output Level (0 dB = 1 volt per μbar)	Open Circuit Voltage . . . . . -74 dB (0.2 mV)	Open Circuit Voltage . . . . . -80 dB (0.10 mV)
Output Clipping Level (at 1,000 Hz)	-3 dBV (0.70 V)	800 Ω Load, ILP-1 gain = 0 dB . . . . . 0 dBV (1.0 V) 800 Ω Load, ILP-1 gain = +10 dB . . . . . -7 dBV (0.45 V) 150 Ω Load ILP-1 gain = 0 dB -13 dBV (0.22 V) 150 Ω Load ILP-1 gain = +10 dB . . . . . -21 dBV (0.09 V)
Total Harmonic Distortion	Less than 1% (134 dB SPL at 1,000 Hz)	Less than 1% (132 dB SPL at 1,000 Hz)
Maximum SPL	145 dB	800 Ω Load, ILP-1 gain at 0 dB . . . . . 155 dB 800 Ω Load, ILP-1 gain at +10 dB . . . . . 138 dB 150 Ω Load, ILP-1 gain at 0 dB . . . . . 145 dB 150 Ω Load, ILP-1 gain at +10 dB . . . . . 127 dB
Dynamic Range (maximum SPL to A-weighted noise level)	111 dB	121 dB (800 Ω load, ILP-1 gain at 0 dB)
Output Noise (equivalent SPL)	34 dB typical, A-weighted 40 dB typical, C-weighted 37 dB, weighted per DIN 45 405	
Hum Pickup (electromagnetic)	N/A	-5 dB equivalent SPL in a 1 mOe field (60 Hz)
Signal-to-Noise Ratio	60 dB at 94 dB SPL (IEC 651)	60 dB at 94 dB SPL (IEC 651)
Response Shaping	N/A	Flat/Lo Cut Preamp switch; Lo Cut: 12 dB rolloff below 80 Hz
Phasing	Positive pressure on microphone diaphragm produces positive voltage on pins 3 and 4 with respect to pin 1 (ground)	Positive pressure on microphone diaphragm produces positive voltage on pin 2 relative to pin 3 of preamplifier output connector
Recommended Operating Voltage	1.5 to 6 V (pin 2 to pins 3 and 4)	11 to 52 Vdc Phantom; operational down to 9 Vdc with reduced clipping level
Current Drain	60 to 180 μA	2.2 mA current drain at 52 Vdc, 1.8 mA at 11 Vdc
Environmental Conditions	Operating Temperatures -18° to 57°C (0° to 135° F) Storage Temperatures . . . . . -29° to 74°C (-20° to 168° F) Relative Humidity . . . . . 0 to 95% (operating or storage)	
Cable	Microphone: 1.12 m (3 ft 8 in.), attached, two-conductor, shielded with miniature 3- and 4-pin connectors (Switchcraft "Tini Q-G" type)	Microphone: 4.6 m (15 ft), two-conductor, shielded with miniature 3-pin female connector (Switchcraft TA4F type) on each end to mate with microphone output and preamplifier input
Case	Microphone: Brass construction with matte black finish and black stainless-steel-mesh grille	Microphone: Brass construction with matte black finish and black stainless-steel-mesh grille Amplifier: Steel construction with matte black enamel finish
Net Weight	Microphone: 12 g (0.4 oz)	Microphone: 12 g (0.4 oz) Amplifier: 170 g (6 oz)
Certifications	Conforms to European Union directives, eligible to bear CE marking; meets European Union EMC Immunity Requirements (EN 50 082-1, 1992); RF radiated (IEC 801-3); ESD (IEC 801-2); EFT (IEC 801-4). 	

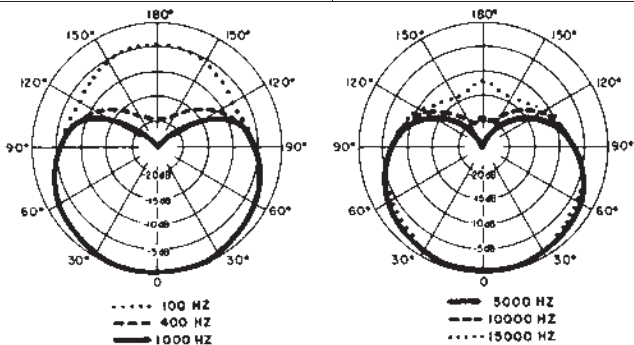

TYPICAL POLAR PATTERNS  
FIGURE 3

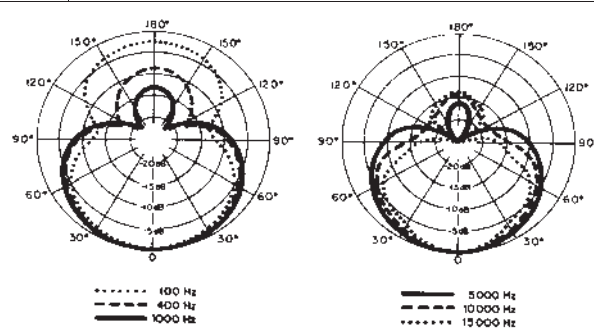

TYPICAL POLAR PATTERNS – SM98A WITH A98SPM  
INSTALLED  
FIGURE 4

**Dimensions**  
See Figure 5

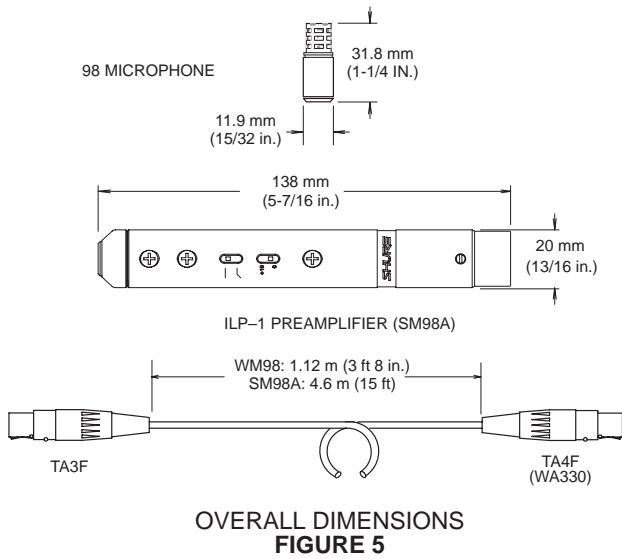

OVERALL DIMENSIONS  
**FIGURE 5**

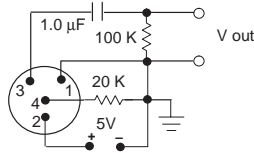

WM98 STANDARD TEST CIRCUIT  
**FIGURE 6**

**INSTALLATION**

To mount the 98 in the supplied swivel adapter:

1. Mount the adapter on a microphone stand.
2. Attach the microphone to the connector.
3. Slip the cable through the slot in the adapter. Slide the connector back through the hole until the protruding black cable lock button is in the open slot and the back of the microphone itself stops flush with the front of the holder. Only the silver metal segment of the connector is held by the holder (see Figure 7).

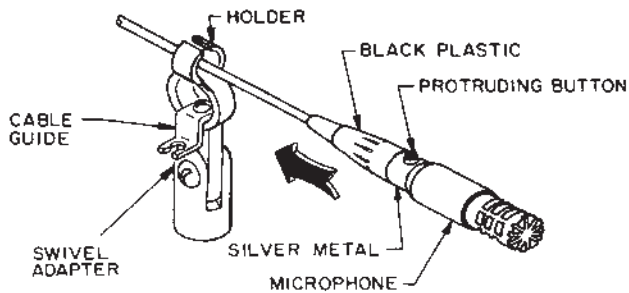

SWIVEL ADAPTER MOUNTING  
**FIGURE 7**

4. Slide the cable through the slot in the cable guide and make a large loop (see Figure 8). Then route the cable away from the stand to prevent transmission of noise and vibration through the cable.

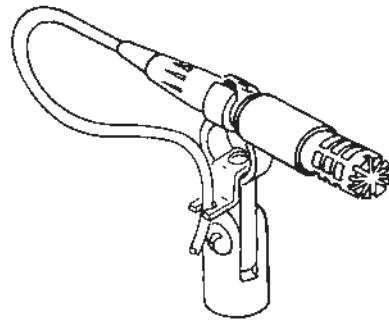

CABLE RETAINED IN GUIDE  
**FIGURE 8**

5. Tilt the adapter to aim the microphone as desired.
6. To remove the microphone without disturbing the swivel adapter and cable, reach into the open slot of the adapter and press the cable-lock button while disengaging the microphone.

**PREAMPLIFIER PERMANENT MOUNTING (SM98A)**

The supplied mounting clamps are intended to hold the preamplifier in place in permanent installations (see Figure 9). Use either one or two clamps depending on location and application.

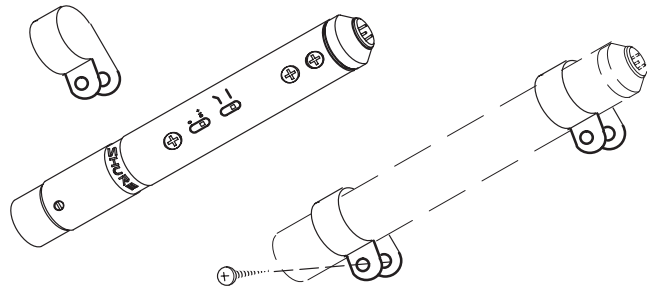

MOUNTING CLAMPS – SM98A PREAMPLIFIER  
**FIGURE 9**

**PREAMPLIFIER SWITCHES**

The preamplifier case contains two miniature recessed slide switches. In the Lo Cut position, the Flat/Lo Cut switch provides a 12 dB rolloff below 80 Hz (see Figure 1). The effects of the 0/+10 dB Gain switch are described in the *Preamplifier Output Clipping Level* specifications.

**INSTALLING THE A98SPM**

The A98SPM Supercardioid Polar Modifier is supplied with the SM98A and is an optional accessory for the WM98. To mount the microphone in an A98SPM Polar Modifier, proceed as follows.

**IMPORTANT**

The white internal element of the A98SPM is essential to maintaining the supercardioid polar pattern. Do **not** remove it!

1. Unscrew the rear support from the front support by turning the rear support counterclockwise (from bottom). See Figure 10.
2. Insert the microphone (cable **not** connected) into the rear support with its connector end contacting the support.
3. Attach the front and rear supports together by turning the rear support clockwise (from bottom). Tighten sufficiently to prevent rattling.

**CAUTION**

Do not overtighten. Damage to the internal element may result.

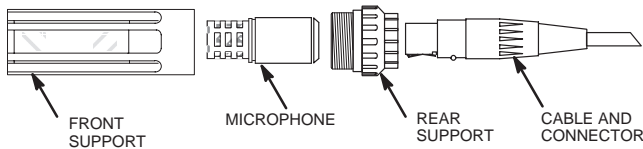

A98SPM ASSEMBLY  
**FIGURE 10**

4. Mount the swivel adapter on the microphone stand.
5. Attach the microphone cable to the 98-A98SPM.
6. Mount the Microphone-Polar Modifier combination in the adapter as in steps 3 through 5 of the *Installation* section.
7. To remove the microphone assembly from the swivel adapter without disturbing the adapter and cable, reach into the open slot of the adapter and press the cable-lock button while disengaging the microphone.
8. NOTE: The Microphone-Polar Modifier assembly can be used with or without its supplied acoustic foam windscreen. When mounted on the SM98A-A98SPM, the windscreen not only provides excellent wind and pop protection, but helps protect the A98SPM internal element from contamination.

**DISASSEMBLING THE PREAMPLIFIER (SM98A)**

1. At the XLR connector end of the preamplifier, turn the slotted head setscrew fully inward (counterclockwise), and use a long-nose pliers to carefully withdraw the connector from the case.
2. Unsolder the three lead wires securing the XLR connector to the XLR board.
3. Remove all four Phillips-head screws from the preamplifier case (three on the switch side, one on the back).
4. Grasp the end cap and withdraw the cap assembly, pc board assembly, and connecting wires and jacks from the case.

**REASSEMBLING THE PREAMPLIFIER (SM98A)**

1. Make sure the pc board is seated in the slot of the end cap and that no wires are pinched.
2. Insert the end cap-board assembly into the case, XLR connecting wires first. Again, take care not to pinch the wires connecting the board to the end cap.
3. Rotate the assembly inside the case until the four holes for Phillips screws line up with the holes in the case.
4. Replace the four Phillips screws.
5. Resolder the three lead wires to the back of the XLR board as shown in Figure 11.

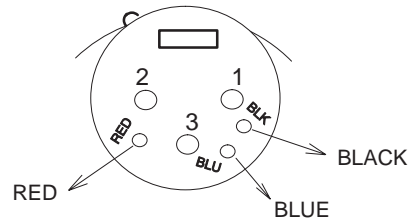

WIRING TO XLR PC BOARD TERMINALS  
**FIGURE 11**

6. Replace the XLR board-connector assembly in the case, lining up the key in the connector with the slot in the case. Take care not to engage the butterfly-shaped ground contact in the key slot as it will prevent seating the connector properly.
7. Insert the connector fully in the case until the slotted setscrew can be seen in the case hole; tighten the setscrew firmly by turning it clockwise.

**OPTIONAL ACCESSORIES**

Drum Mounting Kit .....	A98MKS
Horn Clamp .....	A98KCS
Supercardioid Polar Modifier* .....	A98SPM
Windscreen (for A98SPM)** .....	49A82

\*Supplied with SM98A.  
\*\*Supplied with A98SPM.

**REPLACEMENT PARTS LIST**

Reference Designation	Part Number	Description	Commercial Alternate
<b>Preamplifier (SM98A)</b>			
A1	90B4220	ILP-1 Preamplifier Assembly	None
A2	90HZ2600	Pc Board Assembly	None
MP1	66A264	Preamp Switch Cover	None
MP2	80A476	Mounting Clamp	All States 3/4-HNB
P1	95A8077	Plug Assembly, Male, Miniature 3-Pin	Switchcraft TB3M
P2	90HV2600	XLR-3M Connector and Pc Board Assembly	None
<b>Microphone</b>			
MK1	R134	Microphone Cartridge-Housing	None
MP3	49A66A	Windscreen, Microphone	None
MP4	A98SPM	Supercardioid Polar Modifier (optional for WM98)	None
MP5	49A82	Windscreen, Polar Modifier (optional for WM98)*	None
MP6	RK282	Swivel Adapter	None
P1	95A8077	Plug Assembly, Male, Miniature 3-Pin	Switchcraft TB3M
Part of W1 (WM98)	WA330	Connector, Female, Miniature, 4-Pin	Switchcraft TA4F
W1 (SM98A)	C107	Cable-connector assembly, 4.6 m (15 ft), two-conductor, shielded, 3-pin (female) Switchcraft "Tini Q-G" connectors	None
W1 (WM98)	90A4039	Cable-connector assembly, 1.47 m (5 ft.), two conductor, shielded, 3- and 4-pin Switchcraft "Tini Q-G" connectors	None

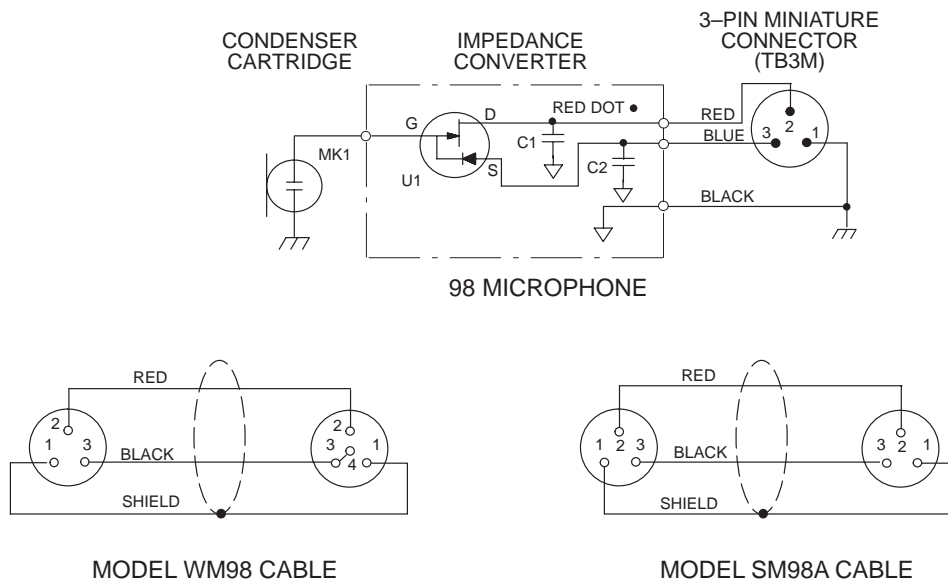

**MICROPHONE WIRING DIAGRAMS  
FIGURE 12**

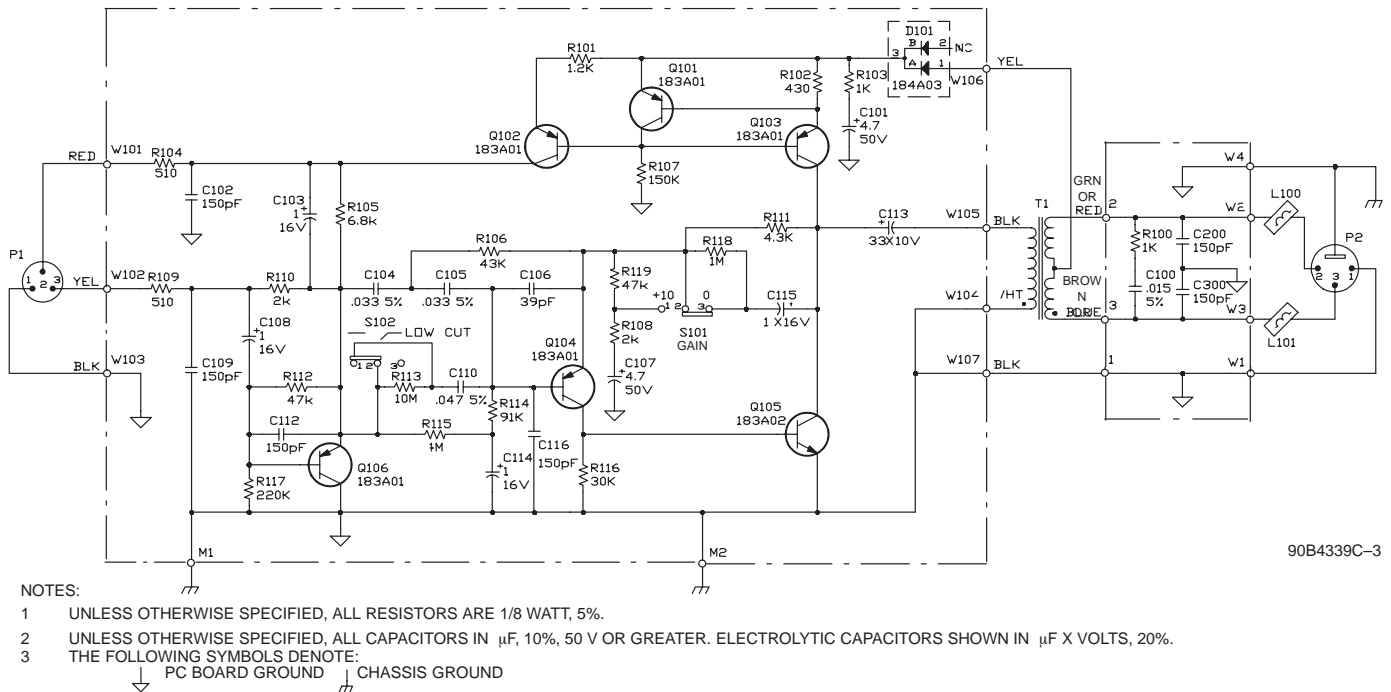

**CIRCUIT DIAGRAM – SM98A PREAMPLIFIER  
FIGURE 13**

## Free Manuals Download Website

<http://myh66.com>

<http://usermanuals.us>

<http://www.somanuals.com>

<http://www.4manuals.cc>

<http://www.manual-lib.com>

<http://www.404manual.com>

<http://www.luxmanual.com>

<http://aubethermostatmanual.com>

Golf course search by state

<http://golfingnear.com>

Email search by domain

<http://emailbydomain.com>

Auto manuals search

<http://auto.somanuals.com>

TV manuals search

<http://tv.somanuals.com>