

# H8SX/1651 Group PLQP0120LA-A User System Interface Board for E6000H Emulator

HS1651ECN61H User's Manual

Renesas Microcomputer Development Environment System

H8SX Family / H8SX/1600 Series

HS1651ECN61HE

Rev.2.00

Revision Date: Sep. 08, 2008

Renesas Technology

[www.renesas.com](http://www.renesas.com)

User's Manual



## Notes regarding these materials

1. This document is provided for reference purposes only so that Renesas customers may select the appropriate Renesas products for their use. Renesas neither makes warranties or representations with respect to the accuracy or completeness of the information contained in this document nor grants any license to any intellectual property rights or any other rights of Renesas or any third party with respect to the information in this document.
2. Renesas shall have no liability for damages or infringement of any intellectual property or other rights arising out of the use of any information in this document, including, but not limited to, product data, diagrams, charts, programs, algorithms, and application circuit examples.
3. You should not use the products or the technology described in this document for the purpose of military applications such as the development of weapons of mass destruction or for the purpose of any other military use. When exporting the products or technology described herein, you should follow the applicable export control laws and regulations, and procedures required by such laws and regulations.
4. All information included in this document such as product data, diagrams, charts, programs, algorithms, and application circuit examples, is current as of the date this document is issued. Such information, however, is subject to change without any prior notice. Before purchasing or using any Renesas products listed in this document, please confirm the latest product information with a Renesas sales office. Also, please pay regular and careful attention to additional and different information to be disclosed by Renesas such as that disclosed through our website. (<http://www.renesas.com>)
5. Renesas has used reasonable care in compiling the information included in this document, but Renesas assumes no liability whatsoever for any damages incurred as a result of errors or omissions in the information included in this document.
6. When using or otherwise relying on the information in this document, you should evaluate the information in light of the total system before deciding about the applicability of such information to the intended application. Renesas makes no representations, warranties or guaranties regarding the suitability of its products for any particular application and specifically disclaims any liability arising out of the application and use of the information in this document or Renesas products.
7. With the exception of products specified by Renesas as suitable for automobile applications, Renesas products are not designed, manufactured or tested for applications or otherwise in systems the failure or malfunction of which may cause a direct threat to human life or create a risk of human injury or which require especially high quality and reliability such as safety systems, or equipment or systems for transportation and traffic, healthcare, combustion control, aerospace and aeronautics, nuclear power, or undersea communication transmission. If you are considering the use of our products for such purposes, please contact a Renesas sales office beforehand. Renesas shall have no liability for damages arising out of the uses set forth above.
8. Notwithstanding the preceding paragraph, you should not use Renesas products for the purposes listed below:
  - (1) artificial life support devices or systems
  - (2) surgical implantations
  - (3) healthcare intervention (e.g., excision, administration of medication, etc.)
  - (4) any other purposes that pose a direct threat to human lifeRenesas shall have no liability for damages arising out of the uses set forth in the above and purchasers who elect to use Renesas products in any of the foregoing applications shall indemnify and hold harmless Renesas Technology Corp., its affiliated companies and their officers, directors, and employees against any and all damages arising out of such applications.
9. You should use the products described herein within the range specified by Renesas, especially with respect to the maximum rating, operating supply voltage range, movement power voltage range, heat radiation characteristics, installation and other product characteristics. Renesas shall have no liability for malfunctions or damages arising out of the use of Renesas products beyond such specified ranges.
10. Although Renesas endeavors to improve the quality and reliability of its products, IC products have specific characteristics such as the occurrence of failure at a certain rate and malfunctions under certain use conditions. Please be sure to implement safety measures to guard against the possibility of physical injury, and injury or damage caused by fire in the event of the failure of a Renesas product, such as safety design for hardware and software including but not limited to redundancy, fire control and malfunction prevention, appropriate treatment for aging degradation or any other applicable measures. Among others, since the evaluation of microcomputer software alone is very difficult, please evaluate the safety of the final products or system manufactured by you.
11. In case Renesas products listed in this document are detached from the products to which the Renesas products are attached or affixed, the risk of accident such as swallowing by infants and small children is very high. You should implement safety measures so that Renesas products may not be easily detached from your products. Renesas shall have no liability for damages arising out of such detachment.
12. This document may not be reproduced or duplicated, in any form, in whole or in part, without prior written approval from Renesas.
13. Please contact a Renesas sales office if you have any questions regarding the information contained in this document, Renesas semiconductor products, or if you have any other inquiries.



# IMPORTANT INFORMATION

## READ FIRST

- **READ** this user's manual before using this user system interface board.
- **KEEP** the user's manual handy for future reference.

**Do not attempt to use the user system interface board until you fully understand its mechanism.**

### **User System Interface Board:**

Throughout this document, the term "user system interface board" shall be defined as the following product produced only by Renesas Technology Corp. excluding all subsidiary products.

- User system interface board (HS1651ECN61H)

The user system or a host computer is not included in this definition.

### **Purpose of the User System Interface Board:**

This user system interface board is for connecting the evaluation chip board and user system. This user system interface board must only be used for the above purpose.

### **Improvement Policy:**

Renesas Technology Corp. (including its subsidiaries, hereafter collectively referred to as Renesas) pursues a policy of continuing improvement in design, performance, functions, and safety of the user system interface board. Renesas reserves the right to change, wholly or partially, the specifications, design, user's manual, and other documentation at any time without notice.

### **Target User of the User System Interface Board:**

This user system interface board should only be used by those who have carefully read and thoroughly understood the information and restrictions contained in the user's manual. Do not attempt to use the user system interface board until you fully understand its mechanism.

It is highly recommended that first-time users be instructed by users that are well versed in the operation of the user system interface board.

## **LIMITED WARRANTY**

Renesas warrants its user system interface boards to be manufactured in accordance with published specifications and free from defects in material and/or workmanship. Renesas will repair or replace any user system interface boards determined to be defective in material and/or workmanship. User system interface boards are wearing parts which Renesas will not repair or replace if damaged and/or worn through use. The foregoing shall constitute the sole remedy for any breach of Renesas' warranty. This warranty extends only to you, the original Purchaser. It is not transferable to anyone who subsequently purchases the user system interface board from you. Renesas is not liable for any claim made by a third party or made by you for a third party.

## **DISCLAIMER**

RENESAS MAKES NO WARRANTIES, EITHER EXPRESS OR IMPLIED, ORAL OR WRITTEN, EXCEPT AS PROVIDED HEREIN, INCLUDING WITHOUT LIMITATION THEREOF, WARRANTIES AS TO MARKETABILITY, MERCHANTABILITY, FITNESS FOR ANY PARTICULAR PURPOSE OR USE, OR AGAINST INFRINGEMENT OF ANY PATENT. IN NO EVENT SHALL RENESAS BE LIABLE FOR ANY DIRECT, INCIDENTAL OR CONSEQUENTIAL DAMAGES OF ANY NATURE, OR LOSSES OR EXPENSES RESULTING FROM ANY DEFECTIVE USER SYSTEM INTERFACE BOARD, THE USE OF ANY USER SYSTEM INTERFACE BOARD, OR ITS DOCUMENTATION, EVEN IF ADVISED OF THE POSSIBILITY OF SUCH DAMAGES. EXCEPT AS EXPRESSLY STATED OTHERWISE IN THIS WARRANTY, THIS USER SYSTEM INTERFACE BOARD IS SOLD "AS IS", AND YOU MUST ASSUME ALL RISK FOR THE USE AND RESULTS OBTAINED FROM THE USER SYSTEM INTERFACE BOARD.

## **State Law:**

Some states do not allow the exclusion or limitation of implied warranties or liability for incidental or consequential damages, so the above limitation or exclusion may not apply to you. This warranty gives you specific legal rights, and you may have other rights which may vary from state to state.

## **The Warranty is Void in the Following Cases:**

Renesas shall have no liability or legal responsibility for any problems caused by misuse, abuse, misapplication, neglect, improper handling, installation, repair or modifications of the user system interface board without Renesas' prior written consent or any problems caused by the user system.

## **All Rights Reserved:**

This user's manual and user system interface board are copyrighted and all rights are reserved by Renesas. No part of this user's manual, all or part, may be reproduced or duplicated in any form, in hard-copy or machine-readable form, by any means available without Renesas' prior written consent.

## **Other Important Things to Keep in Mind:**

1. Circuitry and other examples described herein are meant merely to indicate the characteristics and performance of Renesas' semiconductor products. Renesas assumes no responsibility for any intellectual property claims or other problems that may result from applications based on the examples described herein.
2. No license is granted by implication or otherwise under any patents or other rights of any third party or Renesas.

## **Figures:**

Some figures in this user's manual may show items different from your actual system.

## **Limited Anticipation of Danger:**

Renesas cannot anticipate every possible circumstance that might involve a potential hazard. The warnings in this user's manual and on the user system interface board are therefore not all inclusive. Therefore, you must use the user system interface board safely at your own risk.

# SAFETY PAGE

## READ FIRST

- **READ** this user's manual before using this user system interface board.
- **KEEP** the user's manual handy for future reference.

Do not attempt to use the user system interface board until you fully understand its mechanism.

## DEFINITION OF SIGNAL WORDS



This is the safety alert symbol. It is used to alert you to potential personal injury hazards. Obey all safety messages that follow this symbol to avoid possible injury or death.



**DANGER** indicates an imminently hazardous situation which, if not avoided, will result in death or serious injury.



**WARNING** indicates a potentially hazardous situation which, if not avoided, could result in death or serious injury.



**CAUTION** indicates a potentially hazardous situation which, if not avoided, may result in minor or moderate injury.



**CAUTION** used without the safety alert symbol indicates a potentially hazardous situation which, if not avoided, may result in property damage.

**NOTE** emphasizes essential information.



# **WARNING**

**Observe the precautions listed below. Failure to do so will result in a FIRE HAZARD and will damage the user system and the emulator product or will result in PERSONAL INJURY. The USER PROGRAM will be LOST.**

- 1. Do not repair or remodel the emulator product by yourself for electric shock prevention and quality assurance.**
- 2. Always switch OFF the E6000H emulator and user system before connecting or disconnecting any CABLES or PARTS.**
- 3. Always before connecting any BOARDS, make sure that pin 1 on both sides are correctly aligned.**



# Preface

The HS1651ECN61H is a user system interface board that connects a user system for the H8SX/1651 PQLP0120LA-A (former package: FP-120B) to the H8SX/1650 E6000H emulator (HS1650EPH60H).

# Contents

Preface .....	i
Section 1 Configuration.....	1
Section 2 Connection Procedures .....	3
2.1 Connecting the User System Interface Board to the User System.....	3
2.1.1 Installing the IC Socket.....	3
2.1.2 Soldering the IC Socket .....	4
2.1.3 Installing the IC Socket.....	5
2.1.4 Fastening the Cable Head .....	5
2.2 Exchanging the Spacers of the Evaluation Chip Board .....	7
2.3 Connecting the User System Interface Board to the Evaluation Chip Board .....	8
2.4 Recommended Dimensions for the User System Mounting Pad (Footprint).....	10
2.5 Dimensions of the Evaluation Chip Board and the User System Interface Board.....	11
2.6 Resulting Dimensions after Connecting the User System Interface Board.....	12
Section 3 Installing the MCU on the User System.....	13
Section 4 Verifying Operation.....	15
Section 5 Restriction on the Interface.....	17
Section 6 Points for Caution.....	19

## Section 1 Configuration

Figure 1 and table 1 show the external appearance and components, respectively, of the user system interface board for the PLQP0120LA-A package. Please make sure you have all of these components after you have unpacked the box.

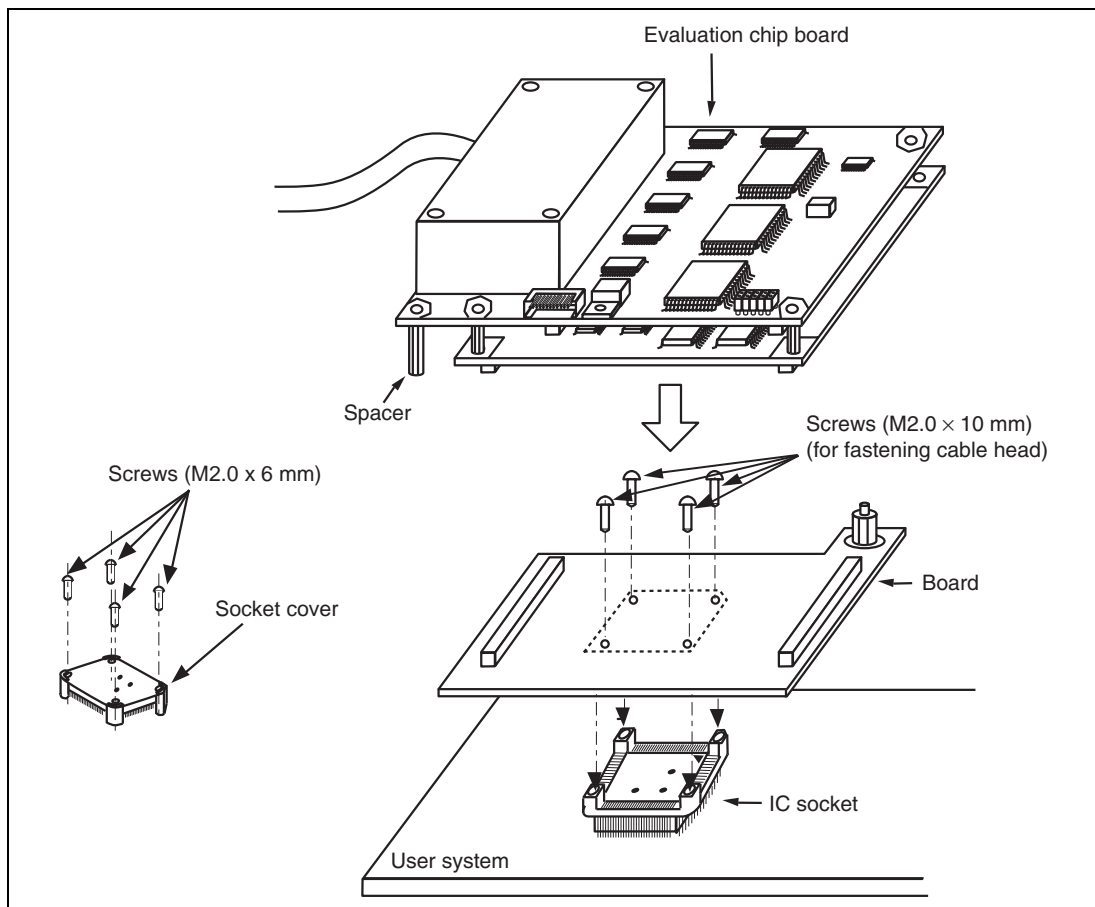

**Figure 1 User System Interface Board for the H8SX/1651 Group PLQP0120LA-A Package**

# CAUTION

**Use an NQPACK120SE-ND socket and an HQPACK120SE cover (manufactured by Tokyo Eletech Corporation) for the PLQP0120LA-A-packaged IC socket on the user system.**

**Table 1 HS1651ECN61H Components**

No.	Component	Quantity	Remarks
1	Board	1	
2	IC socket	1	For the PLQP0120LA-A package
3	Socket cover	1	For installing an PLQP0120LA-A packaged MCU
4	Screw (M2.0 x 10 mm)	4	For fastening cable head
5	Screw (M2.0 x 6 mm)	4	For installing an PLQP0120LA-A packaged MCU
6	Guide pins ( $\phi$ 1 mm)	3	For determining the IC socket location
7	Spacers (2.6 MP x 25 mm)	2	
8	Screwdriver	1	For tightening screws
9	User's manual	1	User's manual for HS1651ECN61H (this manual)

## Section 2 Connection Procedures

### 2.1 Connecting the User System Interface Board to the User System

#### **WARNING**

**Always switch OFF the user system and the emulator product before the USER SYSTEM INTERFACE BOARD is connected or removed. Before connecting the two, make sure that pin 1 on both sides are correctly aligned. Failure to do so will result in a FIRE HAZARD and will damage the user system and the emulator product or will result in PERSONAL INJURY. The USER PROGRAM will be LOST.**

To connect the cable head to the user system, follow the instructions below.

#### 2.1.1 Installing the IC Socket

After checking the location of pin 1 on the IC socket fasten it to the user system before soldering.

#### **CAUTION**

**After confirming the location of pin 1 on the IC socket, apply epoxy resin adhesive to the end of the four projections at the bottom of the IC socket, and fasten it to the user system.**

Use the guide pins provided with the product to determine where to install the IC socket, as shown in figure 2.

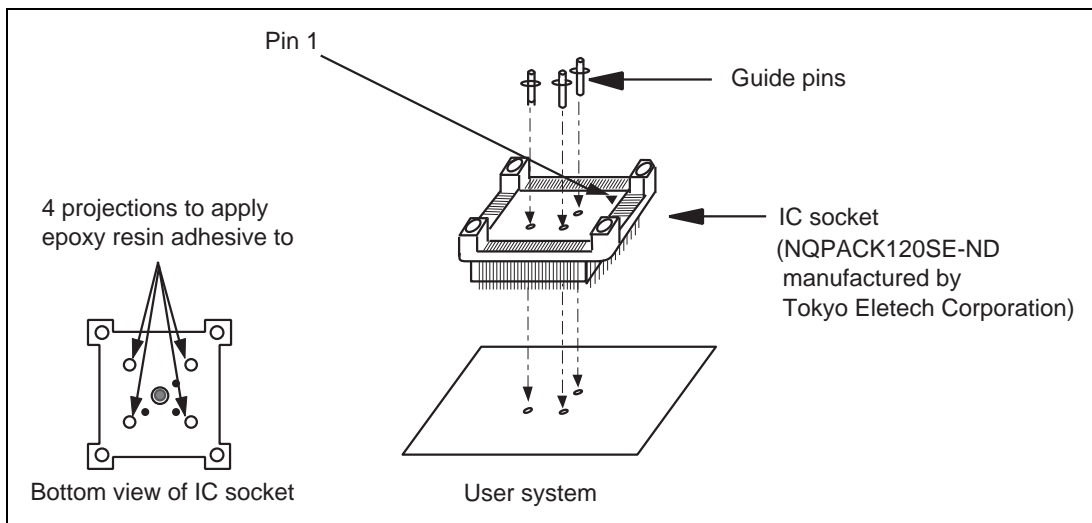

**Figure 2 Correctly Placing the IC Socket**

### 2.1.2 Soldering the IC Socket

After fastening, solder the IC socket for an PLQP0120LA-A package to the user system.

## CAUTION

**Be sure to completely solder the leads so that the solder gently covers the leads and forms solder fillets. (Use slightly more solder than with the MCU.)**



### 2.1.3 Installing the IC Socket

## CAUTION

**Check the location of pin 1 before inserting.**

After checking the location of pin 1 on the user system interface board and pin 1 on the IC socket connector, align the guide pins on the IC socket connector with the guide holes on the user system interface board, and insert the IC socket connector into the IC socket (figure 3).

### 2.1.4 Fastening the Cable Head

## CAUTION

- 1. Use a screwdriver whose head matches the screw head.**
- 2. The tightening torque must be 0.054 N•m or less.  
If the applied torque cannot be accurately measured, stop tightening when the force required to turn the screw becomes significantly greater than that needed when first tightening. If a screw is tightened too much, the screw head may break or an IC socket contact error may be caused by a crack in the IC socket solder.**
- 3. If the emulator does not operate correctly, cracks might have occurred in the solder. Check conduction with a tester and re-solder the IC socket if necessary.**

Fasten the user system interface cable head to the IC socket for an PLQP0120LA-A package on the user system with the four screws (M2.0 x 10 mm) provided. Each screw should be tightened a little at a time, alternating between screws on opposing corners. Take special care, such as by manually securing the IC socket soldered area, to prevent the soldered IC socket from being damaged by overtightening the screws or twisting the components.

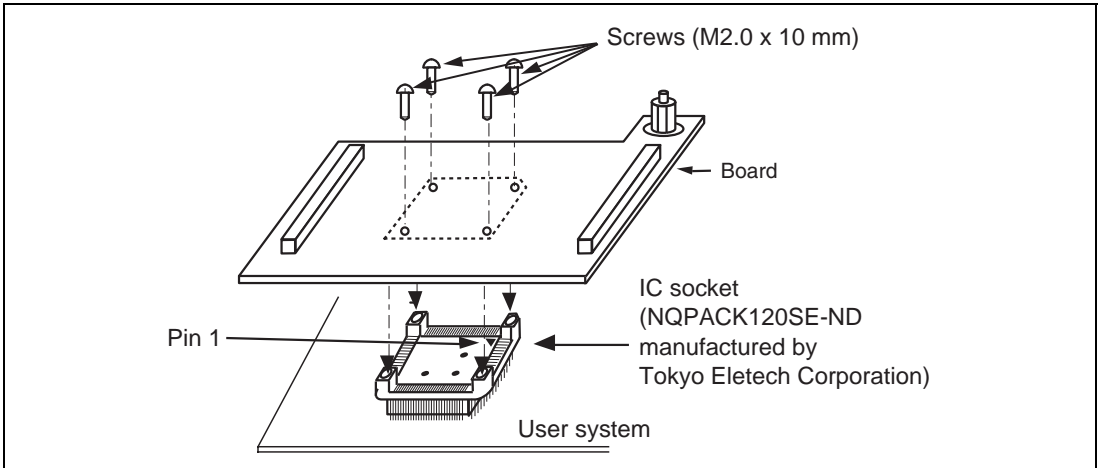
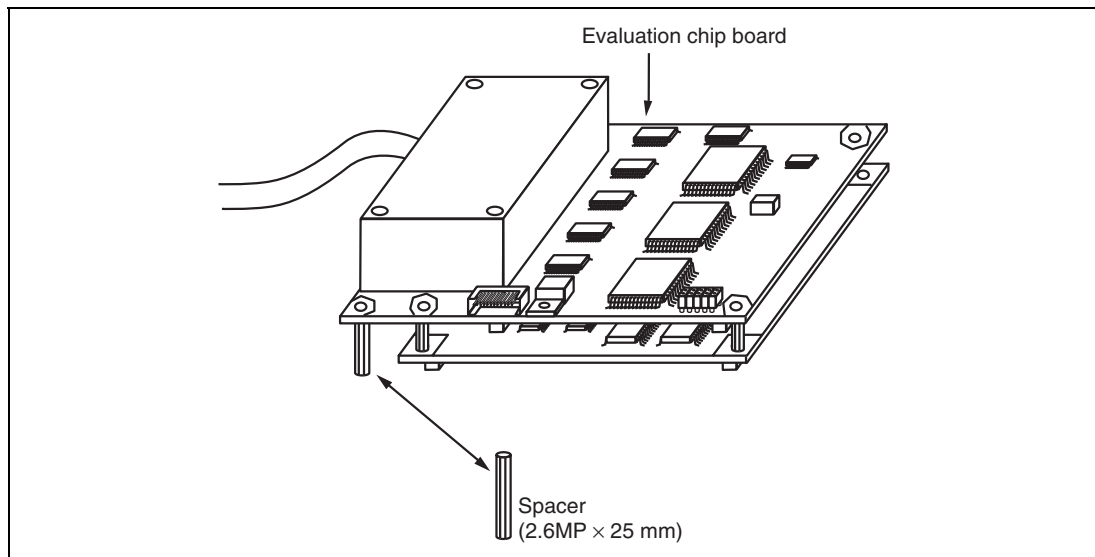

**Figure 3 Connecting the User System Interface Board to the User System**

## 2.2 Exchanging the Spacers of the Evaluation Chip Board

After connecting the user system interface board to the user system, be careful not to apply load to the user system.

Exchange the spacers (2.6MP × 10 mm) for the evaluation chip board with the spacers (2.6MP × 25 mm) provided with the user system interface board.



**Figure 4 Exchanging the Spacers**

## 2.3 Connecting the User System Interface Board to the Evaluation Chip Board

### **WARNING**

**Observe the precautions listed below. Failure to do so will result in a FIRE HAZARD and will damage the user system and the emulator product or will result in PERSONAL INJURY. The USER PROGRAM will be LOST.**

- 1. Always switch OFF the user system and the emulator product before the USER SYSTEM INTERFACE BOARD is connected or removed. Before connecting the two, make sure that the pin 1 positions on both sides are correctly aligned.**
- 2. The user system interface board must be used with the emulator for which it was designed.**

1. Make sure the user system and emulator are turned off.
2. Align the connectors on the user system interface board with those on the evaluation chip board by matching the numbers on the connectors (figure 5).
3. Adjust the height of the spacers of the evaluation chip board to accommodate the user system.

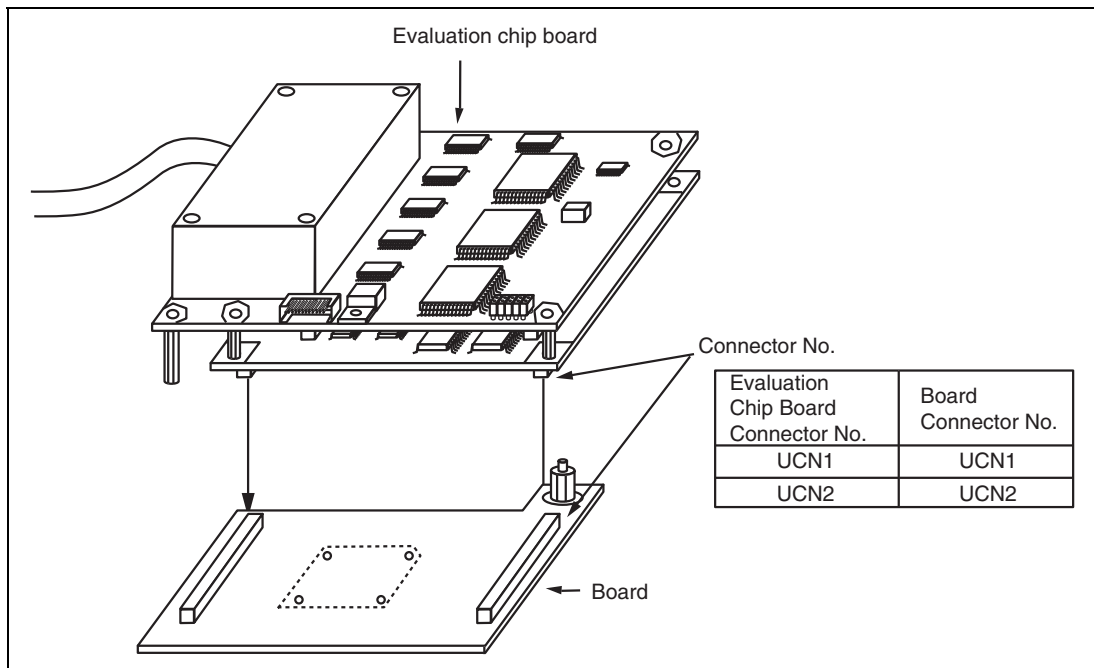

**Figure 5 Connecting the User System Interface Board to the Evaluation Chip Board**

## 2.4 Recommended Dimensions for the User System Mounting Pad (Footprint)

Figure 6 shows the recommended dimensions for the mounting pad (footprint) for the user system with the IC socket for an PLQP0120LA-A package (NQPACK120SE-ND: manufactured by Tokyo Eletech Corporation). The dimensions in figure 6 are somewhat different from those of the mounting pad for the system with the actual MCU. Also, note the user system can not be connected to the user system interface board with inserting the guide pins in place.

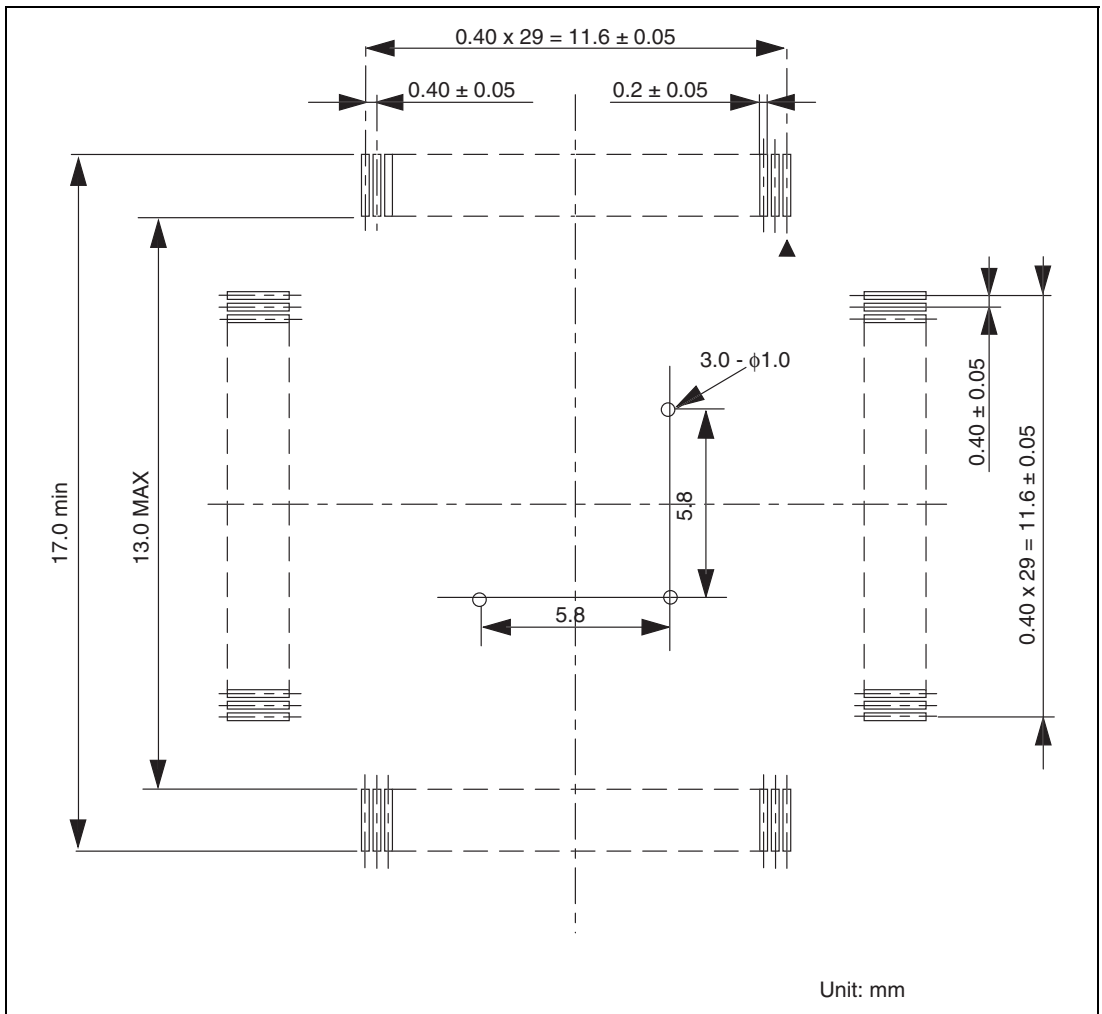

**Figure 6 Recommended Dimensions for the Mounting Pad**

## 2.5 Dimensions of the Evaluation Chip Board and the User System Interface Board

The dimensions of the evaluation chip board and the user system interface board are shown in figure 7.

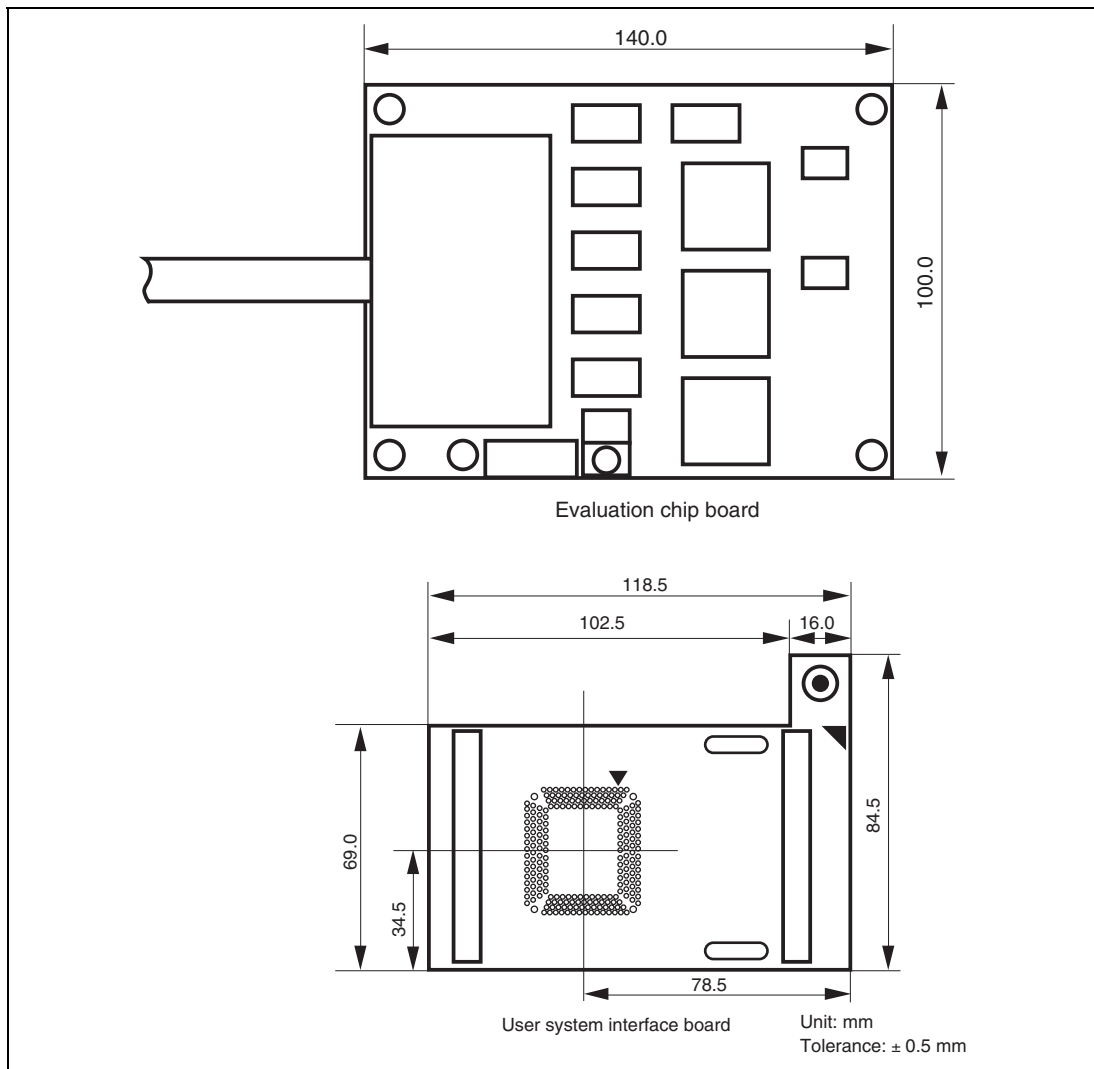

**Figure 7 Dimensions of the Evaluation Chip Board and the User System Interface Board**

## 2.6 Resulting Dimensions after Connecting the User System Interface Board

The dimensions of the assembly after the user system interface board has been connected to the user system, are shown in figure 8.

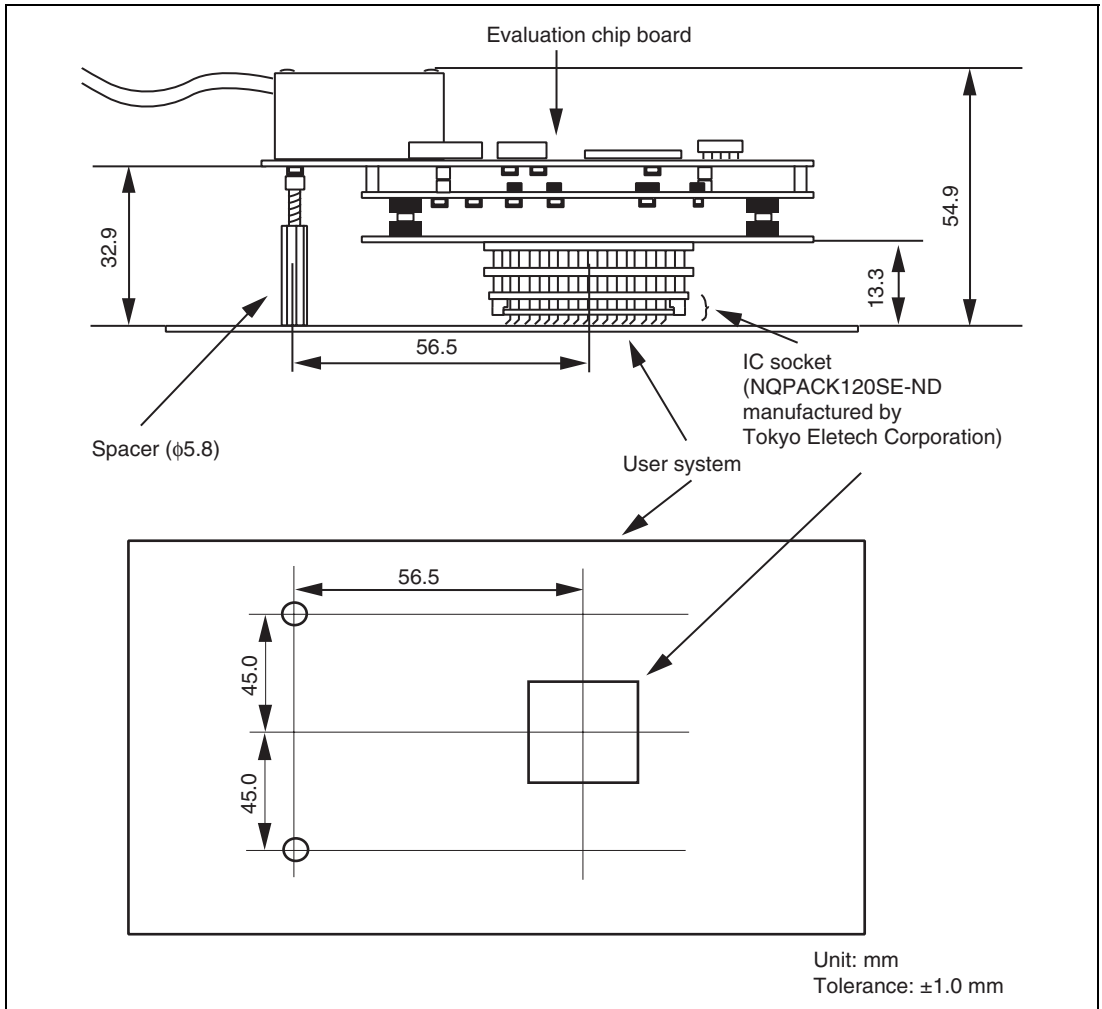

**Figure 8 Dimensions of the Assembly after Connection of the User System Interface Board**



## Section 3 Installing the MCU on the User System

### CAUTION

1. Check the location of pin 1 before inserting the MCU.
2. Use a screwdriver whose head matches the screw head.
3. The tightening torque must be 0.054 N•m or less.  
If the applied torque cannot be accurately measured, stop tightening when the force required to turn the screw becomes significantly greater than that needed when first tightening. If a screw is tightened too much, the screw head may break or an IC socket contact error may be caused by a crack in the IC socket solder.
4. If the MCU does not operate correctly, cracks might have occurred in the solder. Check conduction with a tester and re-solder the IC socket if necessary.

Check the location of pin 1 before inserting the MCU into the IC socket on the user system, as shown in figure 9. After inserting the MCU, fasten the socket cover with the four screws (M2.0 x 6 mm) provided for this. Take special care, such as by manually securing the IC socket soldered area, to prevent the IC socket from being damaged by overtightening the screws or twisting the components.

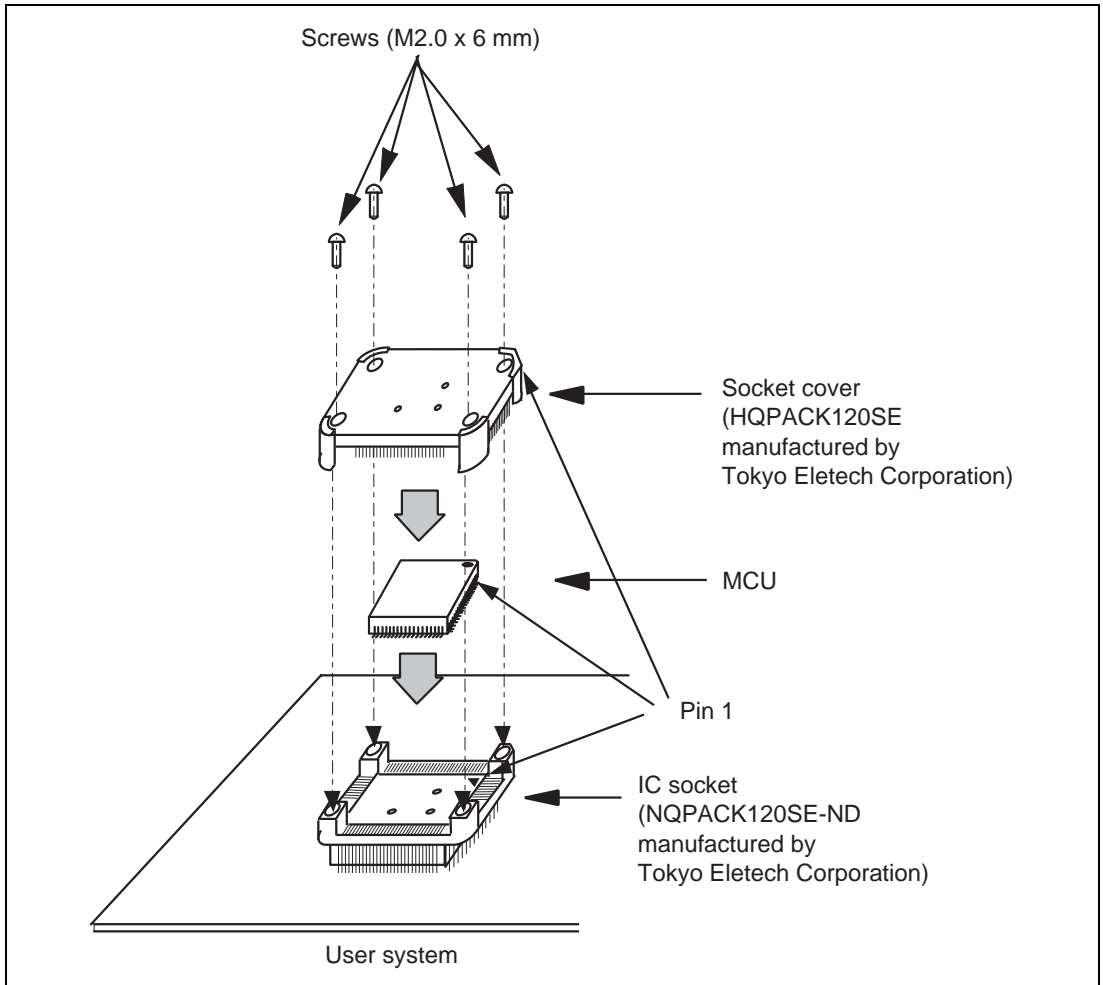
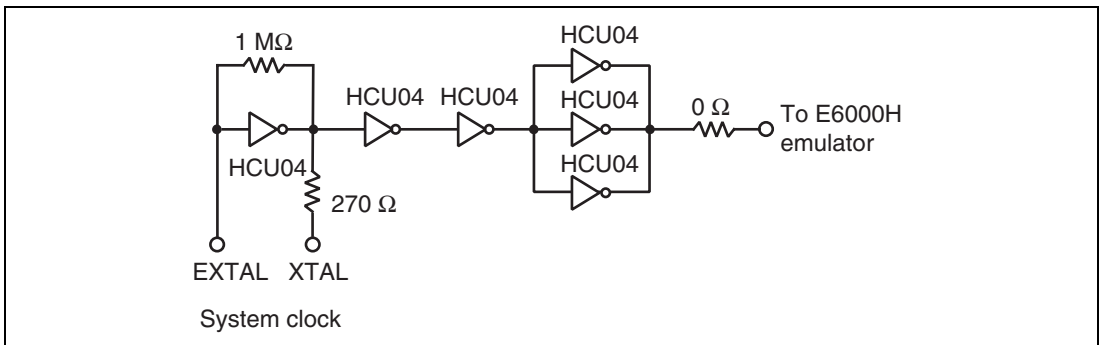

**Figure 9** Installing the MCU on the User System

## Section 4 Verifying Operation

1. Turn on the emulator according to the procedures described in the H8SX/1650 E6000H Emulator User's Manual (HS1650EPH60HE).
2. Verify the user system interface cable connections by checking the pin states with the CHECK command (emulator command) and checking the bus states with the FILL command (emulator command). If an error is detected, recheck the soldered IC socket and the location of pin 1.
3. The emulator connected to this user system interface board supports three kinds of clock sources as the MCU clock. For details, refer to the H8SX/1650 E6000H Emulator User's Manual (HS1650EPH60HE).
  - To use the emulator internal clock  
Select the clock in the emulator by the CLOCK command (emulator command).
  - To use the external clock on the user system  
Supply the external clock from the user system to the emulator by inputting the signal to the EXTAL pin (pin 84) on the user system interface board or connecting a crystal oscillator to the XTAL (pin 83) and EXTAL pins. For details, refer to the H8SX/1651 Hardware Manual.

Figure 10 shows the clock oscillator on the user system interface board.



**Figure 10 Clock Oscillator**

- To use the crystal oscillator mounted on the evaluation chip board  
Install the crystal oscillator into the crystal oscillator terminals on the evaluation chip board.

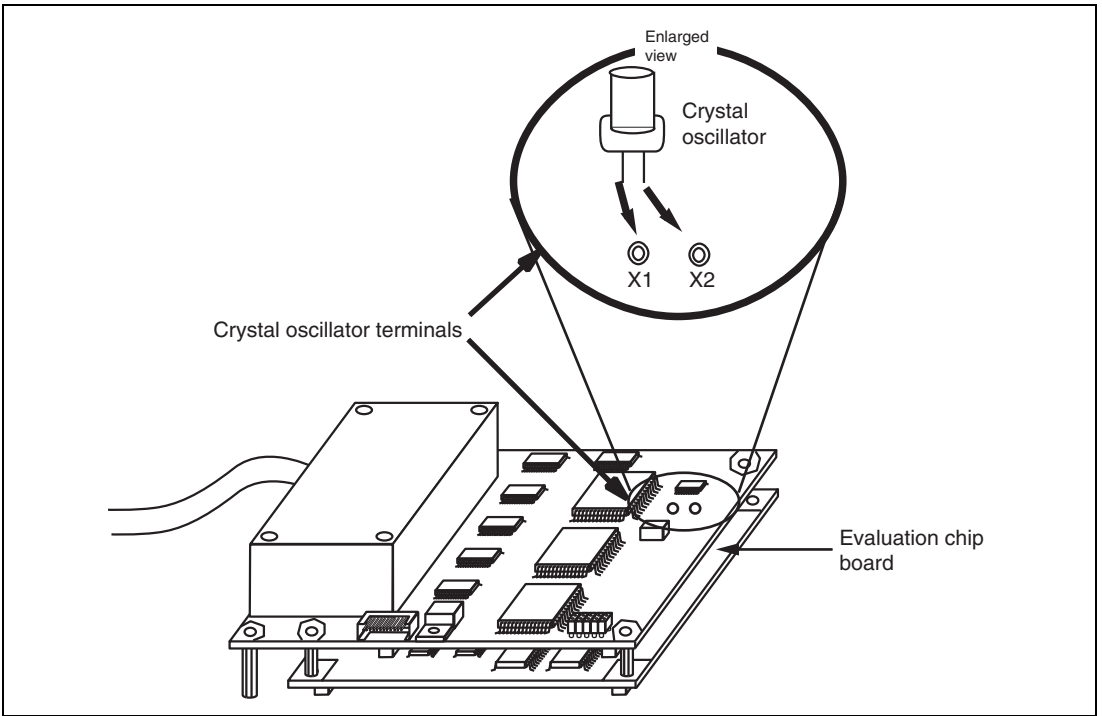
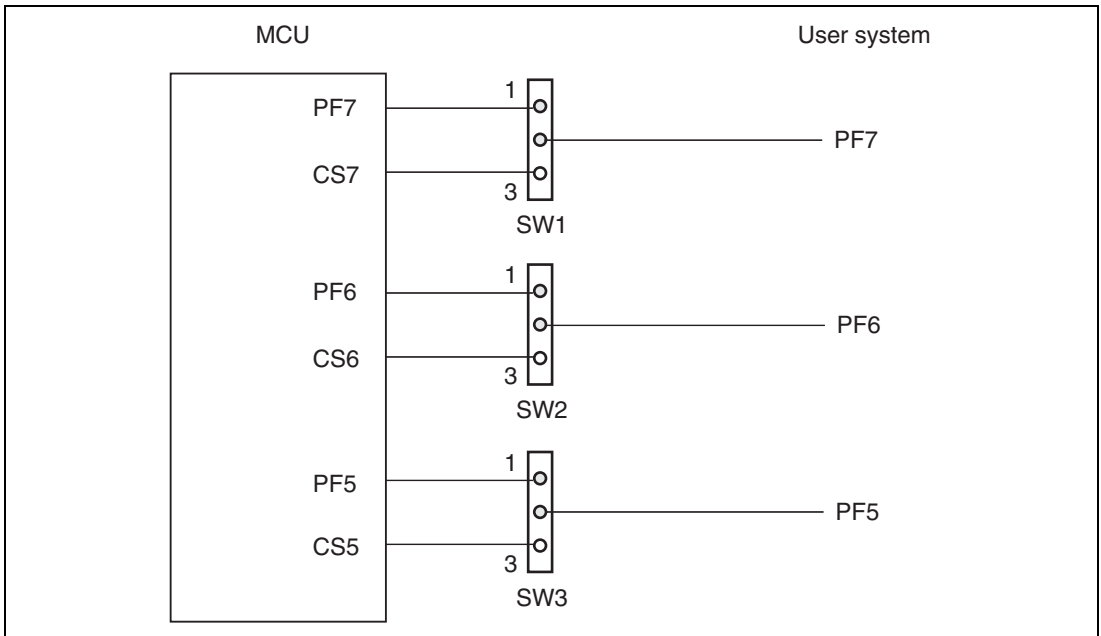

**Figure 11 Installing the Clock Oscillator**

## Section 5 Restriction on the Interface

The following restriction applies to the interface when pins PF7, PF6, and PF5 of the MCU are selected as CS-output pins by the emulator, to which the user system interface board is connected.

Jumper pins (SW1 to SW3) are used to switch the functions of pins PF7, PF6, and PF5 between port and CS-output functions. While these pins are in use as CS-output pins, the functions of PF7, PF6, and PF5 are disabled.

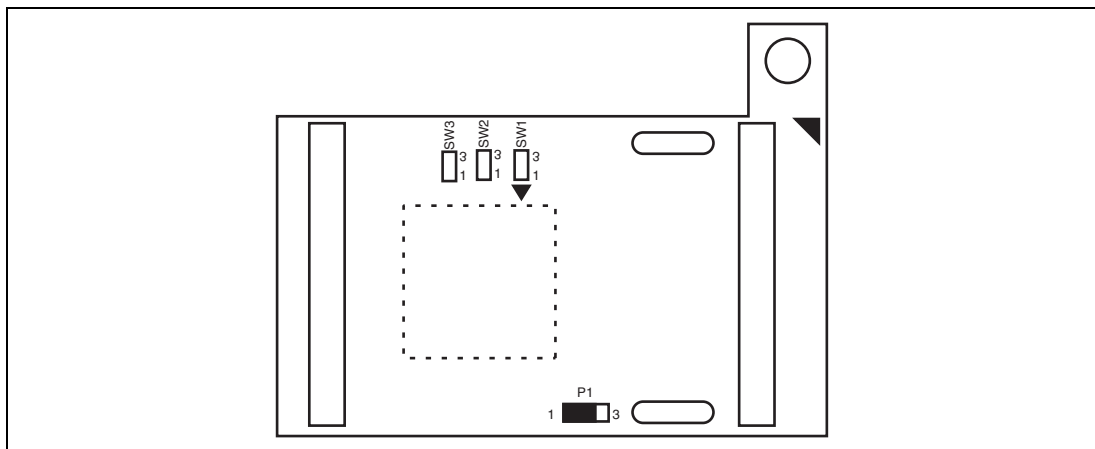

**Figure 12 Interface Circuit**



## Section 6 Points for Caution

1. Before connecting any parts or cables, make sure that the pins at the pin 1 position on both sides are correctly aligned.
2. Do not apply excessive force to the user system interface board while it is connected to the user system.
3. The dimensions of the recommended mounting pad for the IC socket for this user system interface board are different from those of the pad for the MCU.
4. This user system interface board is specifically designed for the HS1650EPH60H emulator. Do not use this board with any other emulator.
5. When power is not being supplied to the Vcc pin on the user system interface board, the emulator displays \*\* VCC DOWN. In this situation, the emulator will not operate correctly.
6. The P1 short connector is used for testing. Do not remove the inserted jumper pin.



**Figure 13 P1 Jumper Socket**

7. The terminals of SW1 to SW3 are used to switch pins between port and CS-output functions. Insert the jumper pins to select the desired function. When the pins are used for CS output, the port functions are disabled. When the port functions of the pins are in use, the CS output functions are disabled. At shipment, the port functions are enabled (i.e., the jumper pins are inserted in “1”).





---

**H8SX/1651 Group PLQP0120LA\_A  
User System Interface Board  
for E6000H Emulator User's Manual**

Publication Date: Rev.2.00, September 8, 2008  
Published by: Sales Strategic Planning Div.  
Renesas Technology Corp.  
Edited by: Customer Support Department  
Global Strategic Communication Div.  
Renesas Solutions Corp.

---

© 2008. Renesas Technology Corp., All rights reserved. Printed in Japan.

Renesas Technology Corp. Sales Strategic Planning Div. Nippon Bldg., 2-6-2, Ohte-machi, Chiyoda-ku, Tokyo 100-0004, Japan

---



## RENESAS SALES OFFICES

<http://www.renesas.com>

Refer to "<http://www.renesas.com/en/network>" for the latest and detailed information.

### **Renesas Technology America, Inc.**

450 Holger Way, San Jose, CA 95134-1368, U.S.A  
Tel: <1> (408) 382-7500, Fax: <1> (408) 382-7501

### **Renesas Technology Europe Limited**

Dukes Meadow, Millboard Road, Bourne End, Buckinghamshire, SL8 5FH, U.K.  
Tel: <44> (1628) 585-100, Fax: <44> (1628) 585-900

### **Renesas Technology (Shanghai) Co., Ltd.**

Unit 204, 205, AZIACenter, No.1233 Lujiazui Ring Rd, Pudong District, Shanghai, China 200120  
Tel: <86> (21) 5877-1818, Fax: <86> (21) 6887-7858/7898

### **Renesas Technology Hong Kong Ltd.**

7th Floor, North Tower, World Finance Centre, Harbour City, Canton Road, Tsimshatsui, Kowloon, Hong Kong  
Tel: <852> 2265-6688, Fax: <852> 2377-3473

### **Renesas Technology Taiwan Co., Ltd.**

10th Floor, No.99, Fushing North Road, Taipei, Taiwan  
Tel: <886> (2) 2715-2888, Fax: <886> (2) 3518-3399

### **Renesas Technology Singapore Pte. Ltd.**

1 Harbour Front Avenue, #06-10, Keppel Bay Tower, Singapore 098632  
Tel: <65> 6213-0200, Fax: <65> 6278-8001

### **Renesas Technology Korea Co., Ltd.**

Kukje Center Bldg. 18th Fl., 191, 2-ka, Hangang-ro, Yongsan-ku, Seoul 140-702, Korea  
Tel: <82> (2) 796-3115, Fax: <82> (2) 796-2145

### **Renesas Technology Malaysia Sdn. Bhd**

Unit 906, Block B, Menara Amcorp, Amcorp Trade Centre, No.18, Jln Persiaran Barat, 46050 Petaling Jaya, Selangor Darul Ehsan, Malaysia  
Tel: <603> 7955-9390, Fax: <603> 7955-9510





# H8SX/1651 Group PLQP0120LA-A User System Interface Board for E6000H Emulator User's Manual



Renesas Technology Corp.

2-6-2, Ote-machi, Chiyoda-ku, Tokyo, 100-0004, Japan

Download from [www.Somanuals.com](http://www.Somanuals.com). All Manuals Search And Download.

## Free Manuals Download Website

<http://myh66.com>

<http://usermanuals.us>

<http://www.somanuals.com>

<http://www.4manuals.cc>

<http://www.manual-lib.com>

<http://www.404manual.com>

<http://www.luxmanual.com>

<http://aubethermostatmanual.com>

Golf course search by state

<http://golfingnear.com>

Email search by domain

<http://emailbydomain.com>

Auto manuals search

<http://auto.somanuals.com>

TV manuals search

<http://tv.somanuals.com>