

H8/3257 Series, H8/325 Series FP-64A
User System Interface Cable
(HS3257ECH61H)
for E6000 Emulator

User's Manual



ADE-xxx-xxx

Rev. 3.0

4/1/03

Renesas Technology Corp.

HS3257ECH61HE

Cautions

1. Renesas neither warrants nor grants licenses of any rights of Renesas's or any third party's patent, copyright, trademark, or other intellectual property rights for information contained in this document. Renesas bears no responsibility for problems that may arise with third party's rights, including intellectual property rights, in connection with use of the information contained in this document.
2. Products and product specifications may be subject to change without notice. Confirm that you have received the latest product standards or specifications before final design, purchase or use.
3. Renesas makes every attempt to ensure that its products are of high quality and reliability. However, contact Renesas's sales office before using the product in an application that demands especially high quality and reliability or where its failure or malfunction may directly threaten human life or cause risk of bodily injury, such as aerospace, aeronautics, nuclear power, combustion control, transportation, traffic, safety equipment or medical equipment for life support.
4. Design your application so that the product is used within the ranges guaranteed by Renesas particularly for maximum rating, operating supply voltage range, heat radiation characteristics, installation conditions and other characteristics. Renesas bears no responsibility for failure or damage when used beyond the guaranteed ranges. Even within the guaranteed ranges, consider normally foreseeable failure rates or failure modes in semiconductor devices and employ systemic measures such as fail-safes, so that the equipment incorporating Renesas product does not cause bodily injury, fire or other consequential damage due to operation of the Renesas product.
5. This product is not designed to be radiation resistant.
6. No one is permitted to reproduce or duplicate, in any form, the whole or part of this document without written approval from Renesas.
7. Contact Renesas's sales office for any questions regarding this document or Renesas semiconductor products.

Preface

Thank you for purchasing the E6000 emulator for the Renesas's original microprocessor H8/300 series.

The HS3257ECH61H is a user system interface cable that connects an H8/300 series E6000 emulator (HS3008EPI60H; hereinafter referred to as the emulator) to the IC socket for a FP-64A package for the H8/3257 series, H8/325 series MCU on the user system.

Contents

Section 1	Configuration.....	1
Section 2	Connection Procedures.....	3
2.1	Connecting User System Interface Cable to Emulator Station.....	3
2.2	Connecting User System Interface Cable to User System.....	4
2.2.1	Installing IC Socket.....	4
2.2.2	Soldering IC Socket.....	5
2.2.3	Inserting Cable Head.....	5
2.2.4	Fastening Cable Head.....	5
2.2.5	Fastening Cable Body.....	7
2.3	Recommended Dimensions for User System Mount Pad.....	8
2.4	Dimensions for User System Interface Cable Head.....	9
2.5	Resulting Dimensions after Connecting User System Interface Cable.....	10
Section 3	Installing the MCU to the User System.....	11
Section 4	Verifying Operation.....	13
Section 5	Notice.....	14

Section 1 Configuration

CAUTION

Use an IC149-064-008-B5 socket (manufactured by YAMAICHI ELECTRONICS Co., Ltd.) for the FP-64A package IC socket on the user system.

Figure 1 shows the configuration of the HS3257ECH61H user system interface cable for the FP-64A package

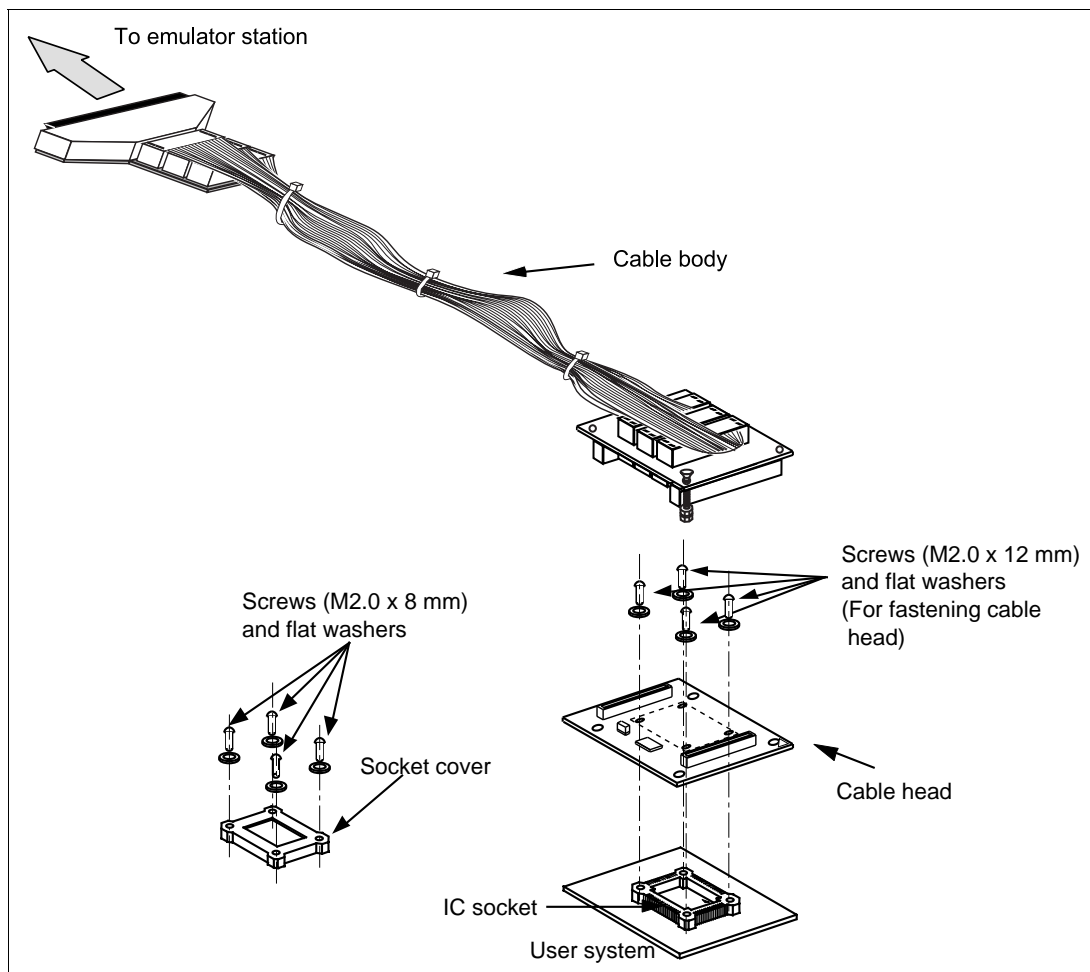

Figure 1 HS3257ECH61H User System Interface Cable

Table 1 lists the HS3257ECH61H components. Please make sure you have all of these components when unpacking.

Table 1 HS3257ECH61H Components

No.	Component	Quantity	Remarks
1	Cable body	1	Includes cables
2	Cable head	1	
3	IC socket	1	For the FP-64A package
4	Socket cover	1	For installing an FP-64A-packaged MCU
5	Screws (M2.0 x 12 mm)	4	For fastening cable head (with four flat washers)
6	Screws (M2.0 x 8 mm)	4	For installing an FP-64A-packaged MCU (with four flat washers)
7	Documentation	1	User's manual for HS3257ECH61H (this manual)

Section 2 Connection Procedures

2.1 Connecting User System Interface Cable to Emulator Station

WARNING

Observe the precautions listed below. Failure to do so will result in a FIRE HAZARD and will damage the user system and the emulator product or will result in PERSONAL INJURY. The USER PROGRAM will be LOST.

- 1. Always switch OFF the user system and the emulator product before the USER SYSTEM INTERFACE CABLE is connected to or removed from any part. Before connecting, make sure that pin 1 on both sides are correctly aligned.**
- 2. The user system interface cable dedicated to the emulator must be used.**

To connect the cable body to the emulator station, follow the instructions below.

1. Make sure the user system and emulator station are turned off.
2. After making sure the direction of the cable body connector is correct, firmly insert the cable body connector into the emulator station socket (figure 2).

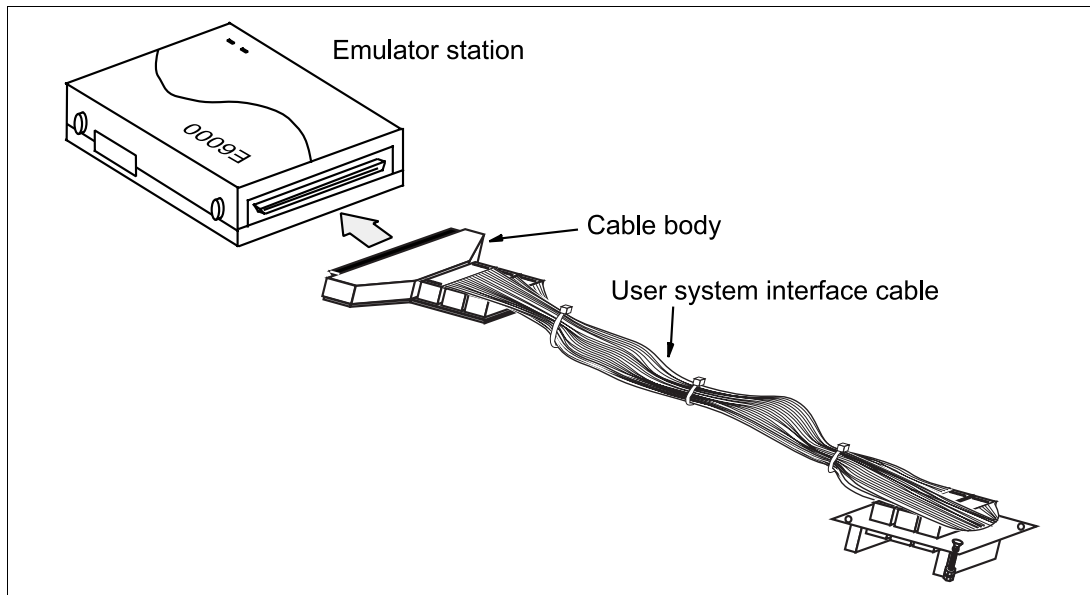

Figure 2 Connecting User System Interface Cable to Emulator Station

2.2 Connecting User System Interface Cable to User System

WARNING

Always switch OFF the user system and the emulator product before the USER SYSTEM INTERFACE CABLE is connected to or removed from any part. Before connecting, make sure that pin 1 on both sides are correctly aligned. Failure to do so will result in a FIRE HAZARD and will damage the user system and the emulator product or will result in PERSONAL INJURY. The USER PROGRAM will be LOST.

To connect the cable head to the user system, follow the instructions below.

2.2.1 Installing IC Socket

After checking the location of pin 1 on the IC socket, apply epoxy resin adhesive to the bottom of the IC socket for an FP-64A package, and fasten it to the user system before soldering.

2.2.2 Soldering IC Socket

After fastening, solder the IC socket for an FP-64A package to the user system. Be sure to completely solder the leads so that the solder slops gently over the leads and forms solder fillets. (Use slightly more solder than the MCU.)

2.2.3 Inserting Cable Head

CAUTION

Check the location of pin 1 before inserting.

Align pin 1 on the IC socket for an FP-64A package on the user system with pin 1 on the user system interface cable head, and insert the user system interface cable head into the IC socket on the user system, as shown in figure 3.

2.2.4 Fastening Cable Head

CAUTION

- 1. Use a Phillips-type screwdriver whose head matches the screw head.**
- 2. The tightening torque must be 0.0784 N•m or less. If the applied torque cannot be accurately measured, stop tightening when the force required to turn the screw becomes significantly greater than that needed when first tightening. If a screw is tightened too much, the screw head may break or an IC socket contact error may be caused by a crack in the IC socket solder.**
- 3. If the emulator does not operate correctly, cracks might have occurred in the solder. Check conduction with a tester and re-solder the IC socket if necessary.**

Fasten the user system interface cable head to the IC socket for an FP-64A package on the user system with the four screws (M2.0 x 12 mm) provided. Each screw should be tightened a little at a time, alternating between screws on opposing corners. Take special care, such as manually securing the IC socket soldered area, to prevent the soldered IC socket from being damaged by overtightening the screws or twisting the components.

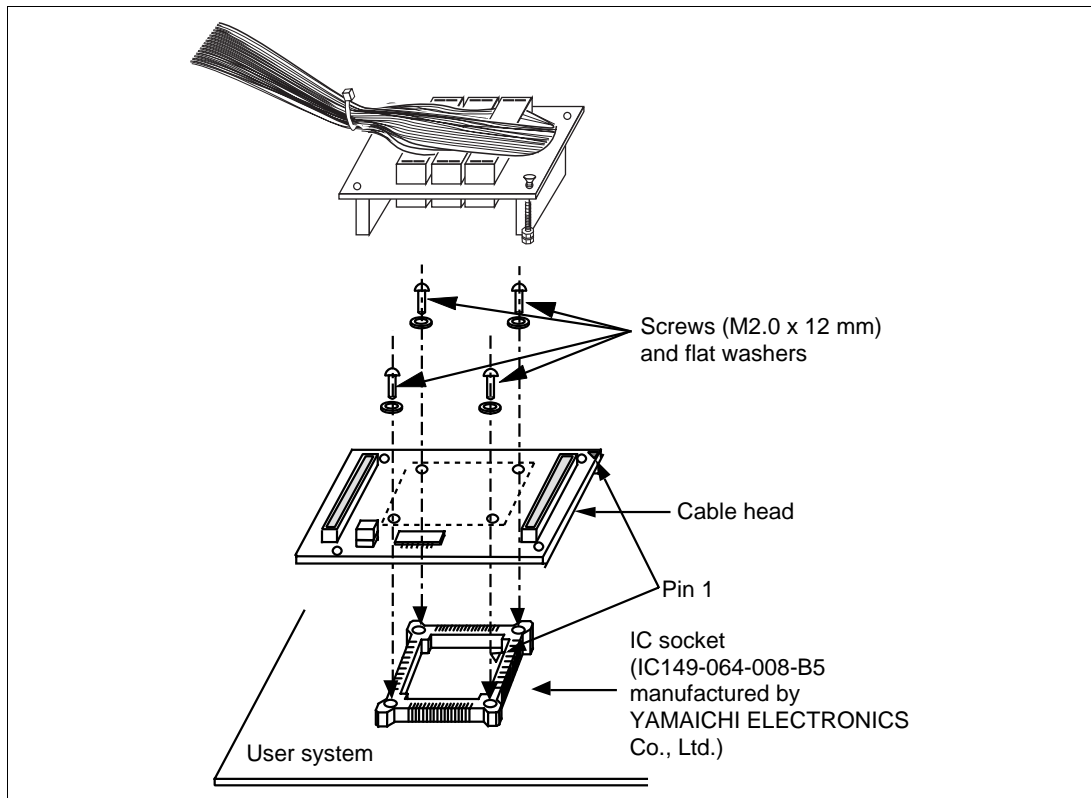

Figure 3 Connecting User System Interface Cable to User System

2.2.5 Fastening Cable Body

Connect the cable body to the cable head.

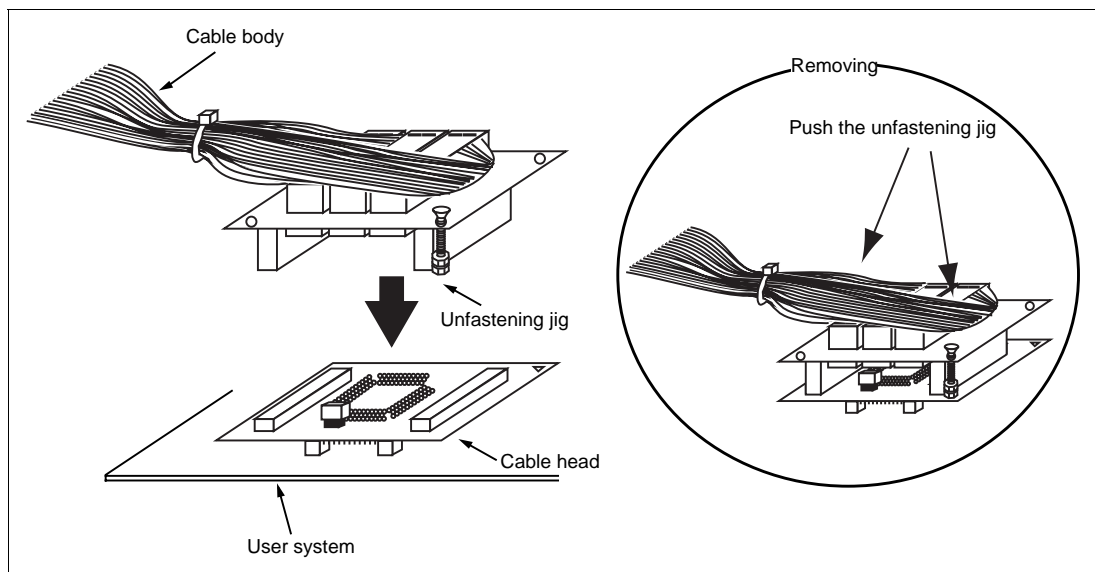

Figure 4 Fastening Cable Body

2.3 Recommended Dimensions for User System Mount Pad

Figure 5 shows the recommended dimensions for the mount pad (footprint) for the user system with an IC socket for an FP-64A package (IC149-064-008-B5: manufactured by YAMAICHI ELECTRONICS Co., Ltd.). Note that the dimensions in figure 5 are somewhat different from those of the actual chip's mount pad.

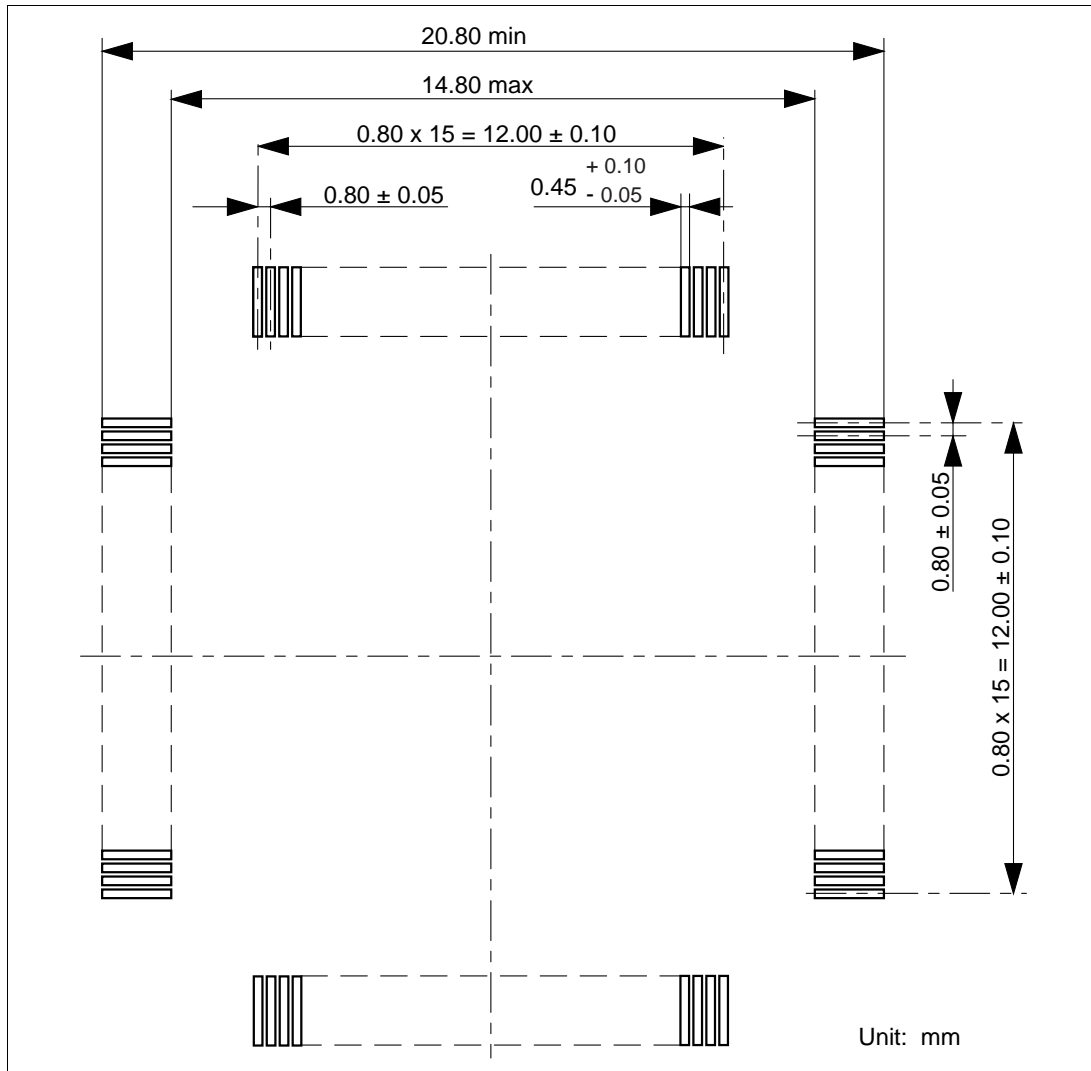

Figure 5 Recommended Dimensions for Mount Pad

2.4 Dimensions for User System Interface Cable Head

The dimensions for the user system interface cable head are shown in figure 6.

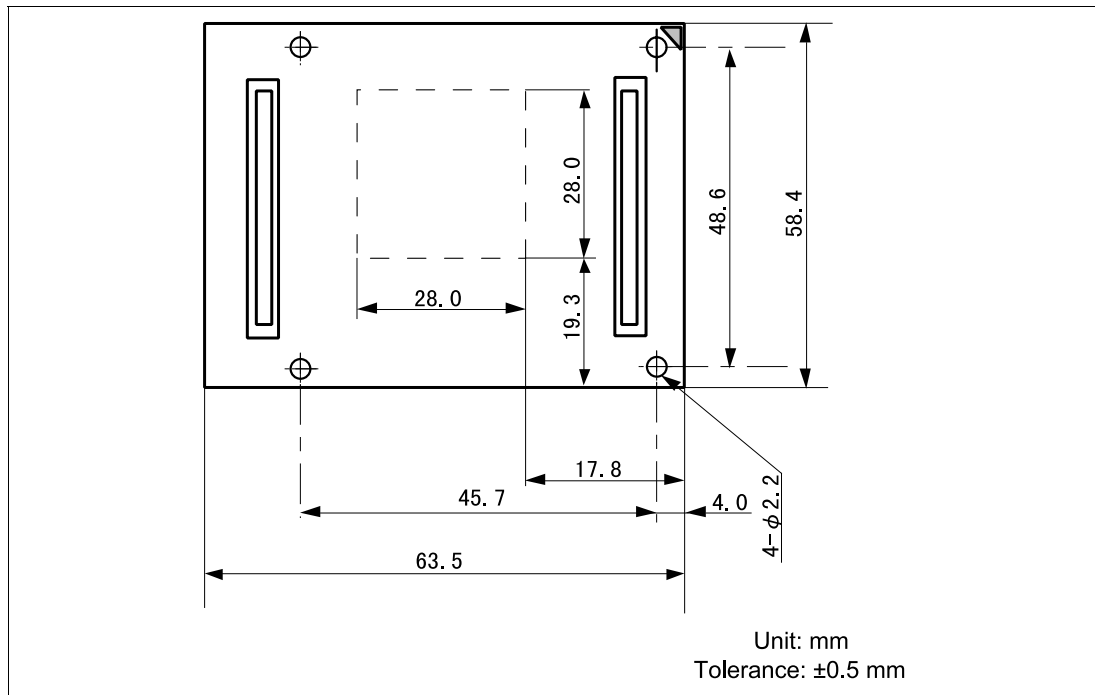

Figure 6 Dimensions for User System Interface Cable Head

2.5 Resulting Dimensions after Connecting User System Interface Cable

The resulting dimensions, after connecting the user system interface cable head to the user system, are shown in figure 7.

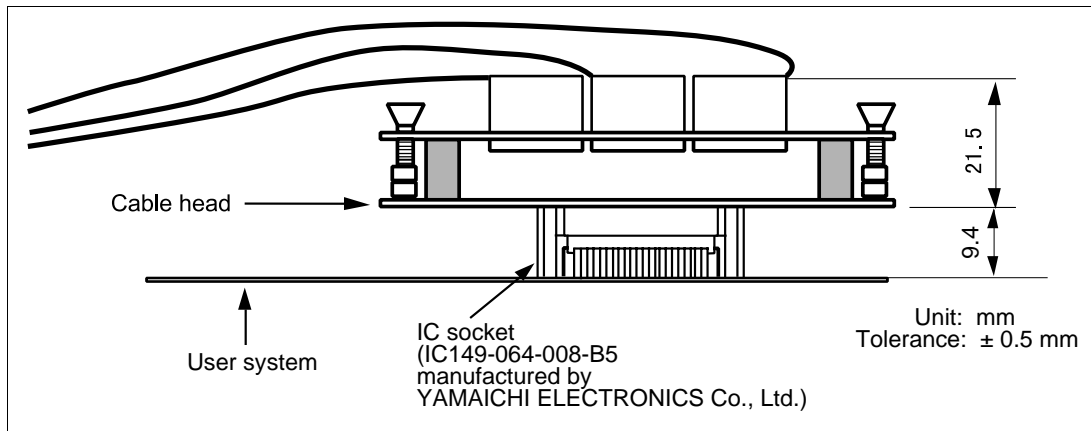

Figure 7 Resulting Dimensions after Connecting User System Interface Cable

Section 3 Installing the MCU to the User System

CAUTION

- 1. Check the location of pin 1 before inserting.**
- 2. Use a Phillips-type screwdriver whose head matches the screw head.**
- 3. The tightening torque must be 0.0784 N•m or less. If the applied torque cannot be accurately measured, stop tightening when the force required to turn the screw becomes significantly greater than that needed when first tightening. If a screw is tightened too much, the screw head may break or an IC socket contact error may be caused by a crack in the IC socket solder.**
- 4. If the MCU does not operate correctly, cracks might have occurred in the solder. Check conduction with a tester and re-solder the IC socket if necessary.**

Check the location of pin 1 before inserting the MCU into the IC socket on the user system, as shown in figure 8. After inserting the MCU, fasten the socket cover with the provided four screws (M2.0 x 8 mm). Take special care, such as manually securing the IC socket soldered area, to prevent the IC socket from being damaged by overtightening the screws or twisting the components.

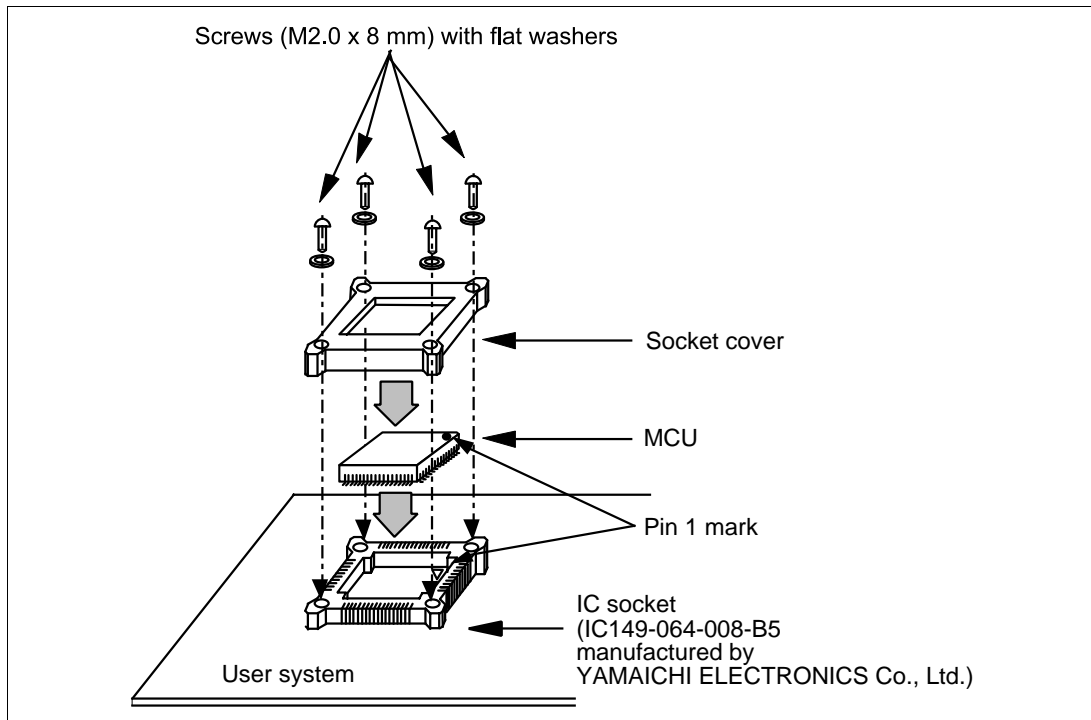

Figure 8 Installing MCU to User System

Section 4 Verifying Operation

1. When using the H8/300 series E6000 emulator (HS3008EPI60H), turn on the emulator according to the procedures described in the H8/300 Series E6000 Emulator User's Manual (HS3008EPI60HE).
2. Verify the user system interface cable connections by accessing the external memory and ports to check the bus states of the pins. If an error is detected, recheck the soldered IC socket and the location of pin 1.
3. The emulator connected to this user system interface cable supports two kinds of clock sources: an emulator internal clock and an external clock on the user system. For details, refer to the H8/300 Series E6000 Emulator User's Manual (HS3008EPI60HE).

— To use the emulator internal clock

Select the clock in the emulator station as the system clock (ϕ), by using the CLOCK command (emulator command).

— To use the external clock on the user system as the system clock

Select target clock t or t with the CLOCK command (emulator command). Supply the external clock from the user system to the emulator. Connect a crystal oscillator to the EXTAL and XTAL terminals for the system clock. The system clock (ϕ) has the same frequency as the external clock.

Figure 9 shows the oscillator circuit on the user system interface cable.

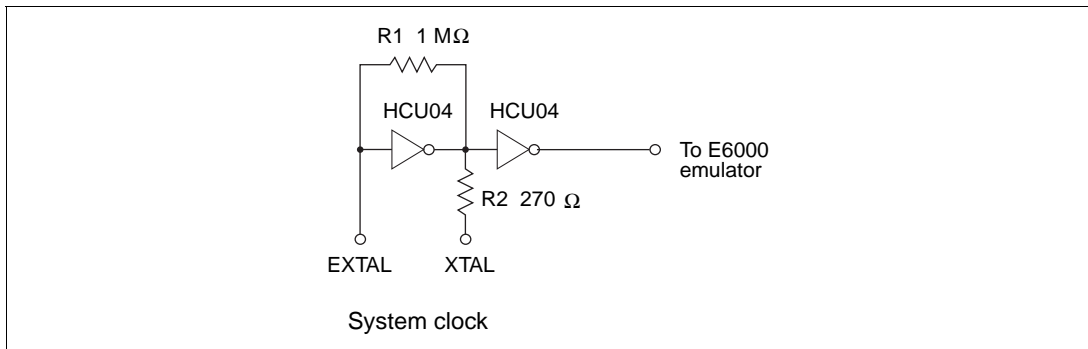

Figure 9 Oscillator Circuit

Section 5 Notice

1. Make sure that pin 1 on the user system IC socket is correctly aligned with pin 1 on the cable head before inserting the cable head into the user system IC socket.
2. The dimensions of the recommended mount pad for the user system IC socket are different from those of the MCU.
3. This user system interface cable is specifically designed for the HS3008EPI60H emulator. Do not use this cable with any other emulator station.
4. To prevent breaking of wires in the cable body, do not place heavy or sharp metal objects on the user system interface cable.
5. While the emulator station is connected to the user system with the user system interface cable, force must not be applied to the cable head. Place the emulator station, user system interface cable, and user system as shown in the example in figure 10.

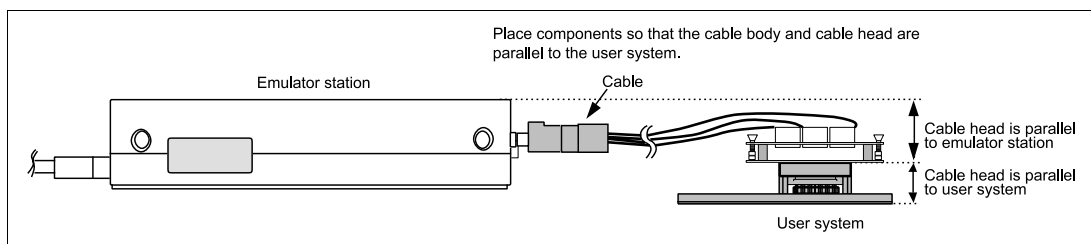

Figure 10 User Cable Location Example

6. The P1 short connector is used for testing. Do not remove the inserted jumper pin.

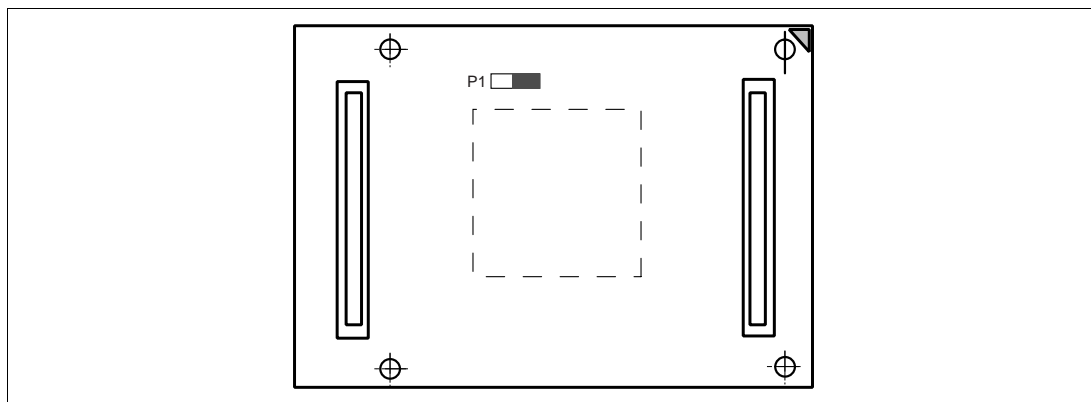

Figure 11 P1 Short Connector

Free Manuals Download Website

<http://myh66.com>

<http://usermanuals.us>

<http://www.somanuals.com>

<http://www.4manuals.cc>

<http://www.manual-lib.com>

<http://www.404manual.com>

<http://www.luxmanual.com>

<http://aubethermostatmanual.com>

Golf course search by state

<http://golfingnear.com>

Email search by domain

<http://emailbydomain.com>

Auto manuals search

<http://auto.somanuals.com>

TV manuals search

<http://tv.somanuals.com>