

**H8/3048 Group, H8/3052 Group, H8/3062 Group,
H8/3067 Group, H8/3007 Group FP-100B/TFP-100B
User System Interface Cable for E6000 Emulator**

HS3064BECH61H User's Manual
HS3064BECH61HE

Renesas Microcomputer Development Environment System

H8 Family / H8/300H Series

Users Manual

Rev.4.00

Revision Date: Aug. 20, 2008

Renesas Technology

www.renesas.com

Notes regarding these materials

1. This document is provided for reference purposes only so that Renesas customers may select the appropriate Renesas products for their use. Renesas neither makes warranties or representations with respect to the accuracy or completeness of the information contained in this document nor grants any license to any intellectual property rights or any other rights of Renesas or any third party with respect to the information in this document.
2. Renesas shall have no liability for damages or infringement of any intellectual property or other rights arising out of the use of any information in this document, including, but not limited to, product data, diagrams, charts, programs, algorithms, and application circuit examples.
3. You should not use the products or the technology described in this document for the purpose of military applications such as the development of weapons of mass destruction or for the purpose of any other military use. When exporting the products or technology described herein, you should follow the applicable export control laws and regulations, and procedures required by such laws and regulations.
4. All information included in this document such as product data, diagrams, charts, programs, algorithms, and application circuit examples, is current as of the date this document is issued. Such information, however, is subject to change without any prior notice. Before purchasing or using any Renesas products listed in this document, please confirm the latest product information with a Renesas sales office. Also, please pay regular and careful attention to additional and different information to be disclosed by Renesas such as that disclosed through our website. (<http://www.renesas.com>)
5. Renesas has used reasonable care in compiling the information included in this document, but Renesas assumes no liability whatsoever for any damages incurred as a result of errors or omissions in the information included in this document.
6. When using or otherwise relying on the information in this document, you should evaluate the information in light of the total system before deciding about the applicability of such information to the intended application. Renesas makes no representations, warranties or guarantees regarding the suitability of its products for any particular application and specifically disclaims any liability arising out of the application and use of the information in this document or Renesas products.
7. With the exception of products specified by Renesas as suitable for automobile applications, Renesas products are not designed, manufactured or tested for applications or otherwise in systems the failure or malfunction of which may cause a direct threat to human life or create a risk of human injury or which require especially high quality and reliability such as safety systems, or equipment or systems for transportation and traffic, healthcare, combustion control, aerospace and aeronautics, nuclear power, or undersea communication transmission. If you are considering the use of our products for such purposes, please contact a Renesas sales office beforehand. Renesas shall have no liability for damages arising out of the uses set forth above.
8. Notwithstanding the preceding paragraph, you should not use Renesas products for the purposes listed below:
 - (1) artificial life support devices or systems
 - (2) surgical implantations
 - (3) healthcare intervention (e.g., excision, administration of medication, etc.)
 - (4) any other purposes that pose a direct threat to human lifeRenesas shall have no liability for damages arising out of the uses set forth in the above and purchasers who elect to use Renesas products in any of the foregoing applications shall indemnify and hold harmless Renesas Technology Corp., its affiliated companies and their officers, directors, and employees against any and all damages arising out of such applications.
9. You should use the products described herein within the range specified by Renesas, especially with respect to the maximum rating, operating supply voltage range, movement power voltage range, heat radiation characteristics, installation and other product characteristics. Renesas shall have no liability for malfunctions or damages arising out of the use of Renesas products beyond such specified ranges.
10. Although Renesas endeavors to improve the quality and reliability of its products, IC products have specific characteristics such as the occurrence of failure at a certain rate and malfunctions under certain use conditions. Please be sure to implement safety measures to guard against the possibility of physical injury, and injury or damage caused by fire in the event of the failure of a Renesas product, such as safety design for hardware and software including but not limited to redundancy, fire control and malfunction prevention, appropriate treatment for aging degradation or any other applicable measures. Among others, since the evaluation of microcomputer software alone is very difficult, please evaluate the safety of the final products or system manufactured by you.
11. In case Renesas products listed in this document are detached from the products to which the Renesas products are attached or affixed, the risk of accident such as swallowing by infants and small children is very high. You should implement safety measures so that Renesas products may not be easily detached from your products. Renesas shall have no liability for damages arising out of such detachment.
12. This document may not be reproduced or duplicated, in any form, in whole or in part, without prior written approval from Renesas.
13. Please contact a Renesas sales office if you have any questions regarding the information contained in this document, Renesas semiconductor products, or if you have any other inquiries.

IMPORTANT INFORMATION

READ FIRST

- **READ** this user's manual before using this user system interface cable.
- **KEEP the user's manual handy for future reference.**

Do not attempt to use the user system interface cable until you fully understand its mechanism.

User System Interface Cable:

Throughout this document, the term "user system interface cable" shall be defined as the following product produced only by Renesas Technology Corp. excluding all subsidiary products.

- User system interface cable (HS3064BECH61H)

The user system or a host computer is not included in this definition.

Purpose of the User System Interface Cable:

This user system interface cable is for connecting the emulator station and user system. This user system interface cable must only be used for the above purpose.

Improvement Policy:

Renesas Technology Corp. (including its subsidiaries, hereafter collectively referred to as Renesas) pursues a policy of continuing improvement in design, performance, functions, and safety of the user system interface cable. Renesas reserves the right to change, wholly or partially, the specifications, design, user's manual, and other documentation at any time without notice.

Target User of the User System Interface Cable:

This user system interface cable should only be used by those who have carefully read and thoroughly understood the information and restrictions contained in the user's manual. Do not attempt to use the user system interface cable until you fully understand its mechanism.

It is highly recommended that first-time users be instructed by users that are well versed in the operation of the user system interface cable.

LIMITED WARRANTY

Renesas warrants its user system interface cables to be manufactured in accordance with published specifications and free from defects in material and/or workmanship. Renesas will repair or replace any user system interface cables determined to be defective in material and/or workmanship. User system interface cables are wearing parts which Renesas will not repair or replace if damaged and/or worn through use. The foregoing shall constitute the sole remedy for any breach of Renesas' warranty. This warranty extends only to you, the original Purchaser. It is not transferable to anyone who subsequently purchases the user system interface cable from you. Renesas is not liable for any claim made by a third party or made by you for a third party.

DISCLAIMER

RENESAS MAKES NO WARRANTIES, EITHER EXPRESS OR IMPLIED, ORAL OR WRITTEN, EXCEPT AS PROVIDED HEREIN, INCLUDING WITHOUT LIMITATION THEREOF, WARRANTIES AS TO MARKETABILITY, MERCHANTABILITY, FITNESS FOR ANY PARTICULAR PURPOSE OR USE, OR AGAINST INFRINGEMENT OF ANY PATENT. IN NO EVENT SHALL RENESAS BE LIABLE FOR ANY DIRECT, INCIDENTAL OR CONSEQUENTIAL DAMAGES OF ANY NATURE, OR LOSSES OR EXPENSES RESULTING FROM ANY DEFECTIVE USER SYSTEM INTERFACE CABLE, THE USE OF ANY USER SYSTEM INTERFACE CABLE, OR ITS DOCUMENTATION, EVEN IF ADVISED OF THE POSSIBILITY OF SUCH DAMAGES. EXCEPT AS EXPRESSLY STATED OTHERWISE IN THIS WARRANTY, THIS USER SYSTEM INTERFACE CABLE IS SOLD "AS IS", AND YOU MUST ASSUME ALL RISK FOR THE USE AND RESULTS OBTAINED FROM THE USER SYSTEM INTERFACE CABLE.

State Law:

Some states do not allow the exclusion or limitation of implied warranties or liability for incidental or consequential damages, so the above limitation or exclusion may not apply to you. This warranty gives you specific legal rights, and you may have other rights which may vary from state to state.

The Warranty is Void in the Following Cases:

Renesas shall have no liability or legal responsibility for any problems caused by misuse, abuse, misapplication, neglect, improper handling, installation, repair or modifications of the user system interface cable without Renesas' prior written consent or any problems caused by the user system.

All Rights Reserved:

This user's manual and user system interface cable are copyrighted and all rights are reserved by Renesas. No part of this user's manual, all or part, may be reproduced or duplicated in any form, in hard-copy or machine-readable form, by any means available without Renesas' prior written consent.

Other Important Things to Keep in Mind:

1. Circuitry and other examples described herein are meant merely to indicate the characteristics and performance of Renesas' semiconductor products. Renesas assumes no responsibility for any intellectual property claims or other problems that may result from applications based on the examples described herein.
2. No license is granted by implication or otherwise under any patents or other rights of any third party or Renesas.

Figures:

Some figures in this user's manual may show items different from your actual system.

Limited Anticipation of Danger:

Renesas cannot anticipate every possible circumstance that might involve a potential hazard. The warnings in this user's manual and on the user system interface cable are therefore not all inclusive. Therefore, you must use the user system interface cable safely at your own risk.

SAFETY PAGE

READ FIRST

- **READ** this user's manual before using this user system interface cable.
- **KEEP** the user's manual handy for future reference.

Do not attempt to use the user system interface cable until you fully understand its mechanism.

DEFINITION OF SIGNAL WORDS



This is the safety alert symbol. It is used to alert you to potential personal injury hazards. Obey all safety messages that follow this symbol to avoid possible injury or death.



DANGER indicates an imminently hazardous situation which, if not avoided, will result in death or serious injury.



WARNING indicates a potentially hazardous situation which, if not avoided, could result in death or serious injury.



CAUTION indicates a potentially hazardous situation which, if not avoided, may result in minor or moderate injury.



CAUTION used without the safety alert symbol indicates a potentially hazardous situation which, if not avoided, may result in property damage.

NOTE emphasizes essential information.

WARNING

Observe the precautions listed below. Failure to do so will result in a FIRE HAZARD and will damage the user system and the emulator product or will result in PERSONAL INJURY. The USER PROGRAM will be LOST.

- 1. Do not repair or remodel the emulator product by yourself for electric shock prevention and quality assurance.**
- 2. Always switch OFF the E6000 emulator and user system before connecting or disconnecting any CABLES or PARTS.**
- 3. Always before connecting any CABLES, make sure that pin 1 on both sides are correctly aligned.**

Preface

Thank you for purchasing this user system interface cable (HS3064BECH61H) for the Renesas' original microcomputers H8/3048 group, H8/3052 group, H8/3062 group, H8/3067 group, and H8/3007 group.

The HS3064BECH61H is a user system interface cable that connects the H8/3048 group, H8/3052 group, H8/3062 group, H8/3067 group, H8/3007 group E6000 emulator (HS3064BEPI61H; hereinafter referred to as the emulator) to the IC socket for an FP-100B/TFP-100B package for the H8/3048 group, H8/3052 group, H8/3062 group, H8/3067 group, H8/3007 group MCU on the user system.

Contents

| | | |
|-----------|---|----|
| Section 1 | Configuration..... | 1 |
| Section 2 | Connection Procedures | 3 |
| 2.1 | Connecting User System Interface Cable to Emulator Station | 3 |
| 2.2 | Connecting User System Interface Cable to User System | 5 |
| 2.2.1 | Installing IC Socket..... | 5 |
| 2.2.2 | Soldering IC Socket | 5 |
| 2.2.3 | Inserting Cable Head..... | 6 |
| 2.2.4 | Fastening Cable Head | 6 |
| 2.2.5 | Fastening Cable Body | 8 |
| 2.3 | Recommended Dimensions for User System Mount Pad | 9 |
| 2.4 | Dimensions for User System Interface Cable Head..... | 10 |
| 2.5 | Resulting Dimensions after Connecting User System Interface Cable | 11 |
| Section 3 | Installing the MCU to the User System..... | 12 |
| Section 4 | Verifying Operation..... | 14 |
| Section 5 | Notice..... | 15 |

Section 1 Configuration

CAUTION

Use an IC149-100-054-B51 socket (manufactured by YAMAICHI ELECTRONICS Co., Ltd.) for the FP-100B/TFP-100B package IC socket on the user system.

Figure 1 shows the configuration of the HS3064BECH61H user system interface cable for the FP-100B/TFP-100B package.

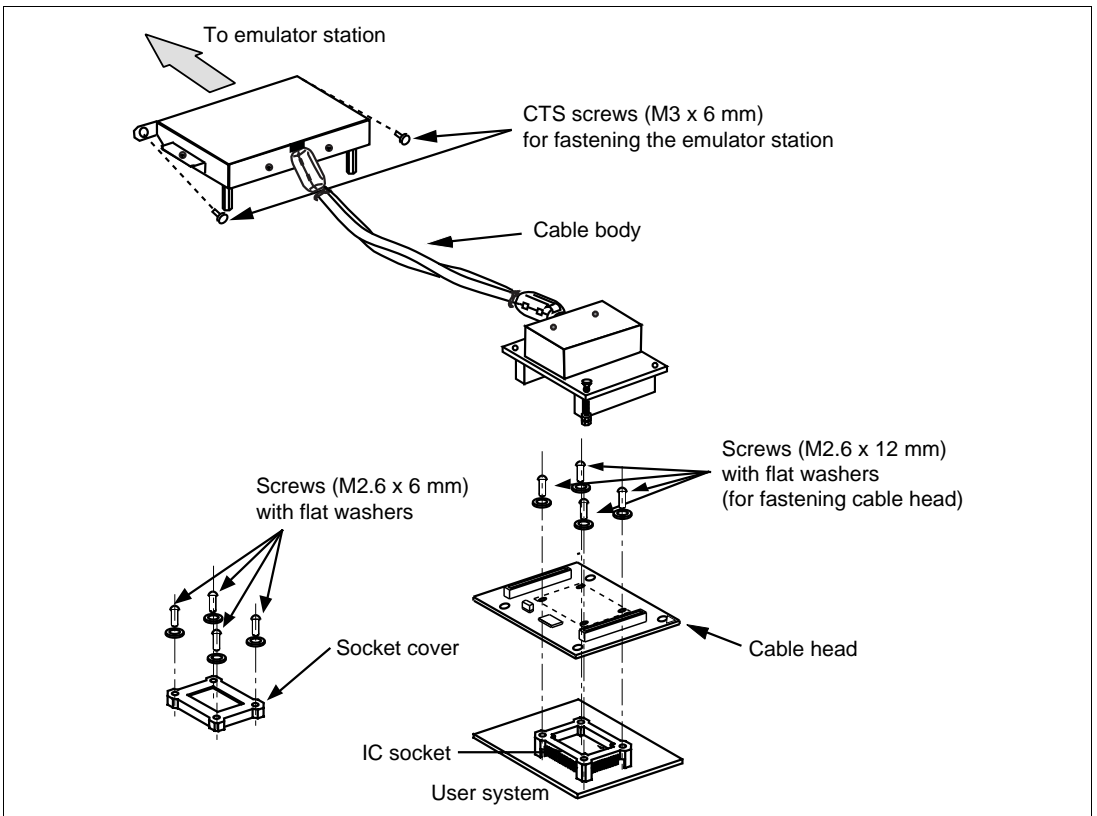

Figure 1 HS3064BECH61H User System Interface Cable

Table 1 lists the HS3064BECH61H components. Please make sure you have all of these components when unpacking.

Table 1 HS3064BECH61H Components

| No. | Component | Quantity | Remarks |
|------------|------------------------|-----------------|--|
| 1 | Cable body | 1 | |
| 2 | Cable head | 1 | |
| 3 | IC socket | 1 | For the FP-100B/TFP-100B package |
| 4 | Socket cover | 1 | For installing an FP-100B/TFP-100B-packaged MCU |
| 5 | Screws (M2.6 x 12 mm) | 4 | For fastening cable head (with four flat washers) |
| 6 | Screws (M2.6 x 6 mm) | 4 | For installing an FP-100B/TFP-100B-packaged MCU (with four flat washers) |
| 7 | CTS screws (M3 x 6 mm) | 2 | For fastening the emulator station |
| 8 | Documentation | 1 | User's manual for HS3064BECH61H (this manual) |

Section 2 Connection Procedures

2.1 Connecting User System Interface Cable to Emulator Station

WARNING

Observe the precautions listed below. Failure to do so will result in a FIRE HAZARD and will damage the user system and the emulator product or will result in PERSONAL INJURY. The USER PROGRAM will be LOST.

- 1. Always switch OFF the user system and the emulator product before the USER SYSTEM INTERFACE CABLE is connected to or removed from any part. Before connecting, make sure that pin 1 on both sides are correctly aligned.**
- 2. The user system interface cable dedicated to the emulator must be used.**

To connect the cable body to the emulator station, follow the instructions below.

1. Make sure the user system and emulator station are turned off.

CAUTION

When connecting or removing the user system interface cable, apply force only in the direction suitable for connection or removal, while making sure not to bend or twist the cable or connectors. Otherwise, the connectors will be damaged.

2. After making sure the direction of the cable body connector is correct, firmly insert the cable body connector into the emulator station socket, and fasten the emulator station with two CTS screw (M3 x 6 mm) (figure 2).

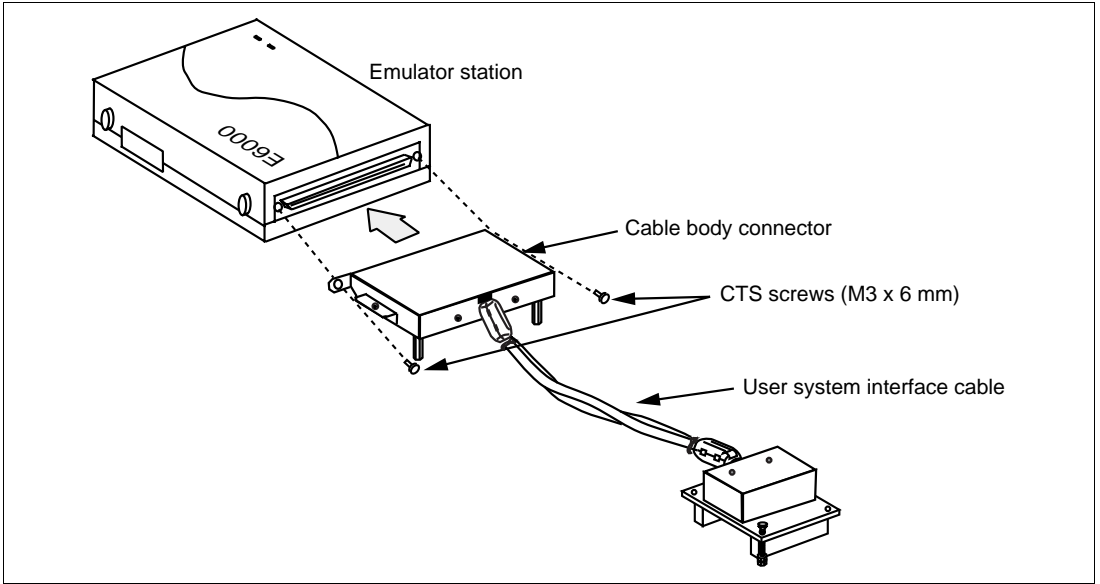

Figure 2 Connecting User System Interface Cable to Emulator Station

2.2 Connecting User System Interface Cable to User System

WARNING

Always switch OFF the user system and the emulator product before the USER SYSTEM INTERFACE CABLE is connected to or removed from any part. Before connecting, make sure that pin 1 on both sides are correctly aligned. Failure to do so will result in a FIRE HAZARD and will damage the user system and the emulator product or will result in PERSONAL INJURY. The USER PROGRAM will be LOST.

To connect the cable head to the user system, follow the instructions below.

2.2.1 Installing IC Socket

After checking the location of pin 1 on the IC socket, apply epoxy resin adhesive to the bottom of the IC socket for an FP-100B/TFP-100B package, and fasten it to the user system before soldering.

2.2.2 Soldering IC Socket

After fastening, solder the IC socket for an FP-100B/TFP-100B package to the user system. Be sure to completely solder the leads so that the solder slopes gently over the leads and forms solder fillets. (Use slightly more solder than the MCU.)

2.2.3 Inserting Cable Head

CAUTION

Check the location of pin 1 before inserting.

Align pin 1 on the IC socket for an FP-100B/TFP-100B package on the user system with pin 1 on the user system interface cable head, and insert the user system interface cable head into the IC socket on the user system, as shown in figure 3.

2.2.4 Fastening Cable Head

CAUTION

- 1. Use a Philips-type screwdriver whose head matches the screw head.**
- 2. The tightening torque must be 0.294 N•m or less. If the applied torque cannot be accurately measured, stop tightening when the force required to turn the screw becomes significantly greater than that needed when first tightening. If a screw is tightened too much, the screw head may break or an IC socket contact error may be caused by a crack in the IC socket solder.**
- 3. If the emulator does not operate correctly, cracks might have occurred in the solder. Check conduction with a tester and re-solder the IC socket if necessary.**

Fasten the user system interface cable head to the IC socket for an FP-100B/TFP-100B package on the user system with the four screws (M2.6 x 12 mm; with four flat washers) provided. Each screw should be tightened a little at a time, alternating between screws on opposing corners. Take special care, such as manually securing the IC socket soldered area, to prevent the soldered IC socket from being damaged by overtightening the screws or twisting the components.

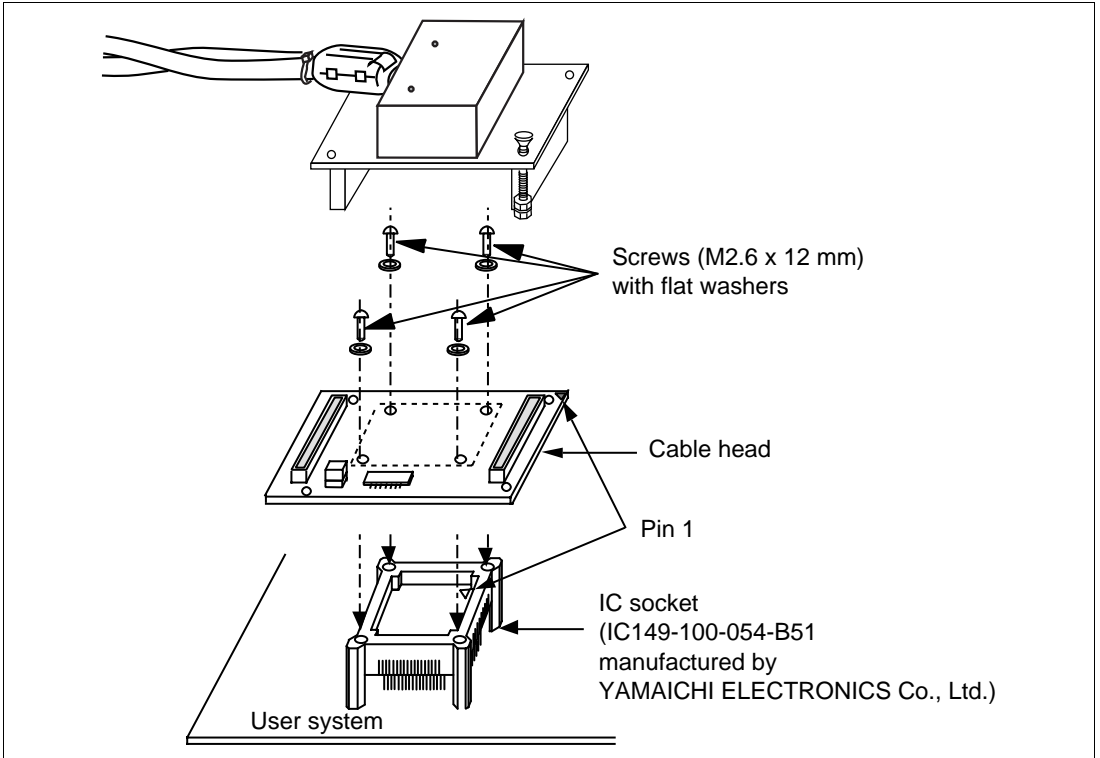

Figure 3 Connecting User System Interface Cable to User System

2.2.5 Fastening Cable Body

Connect the cable body to the cable head.

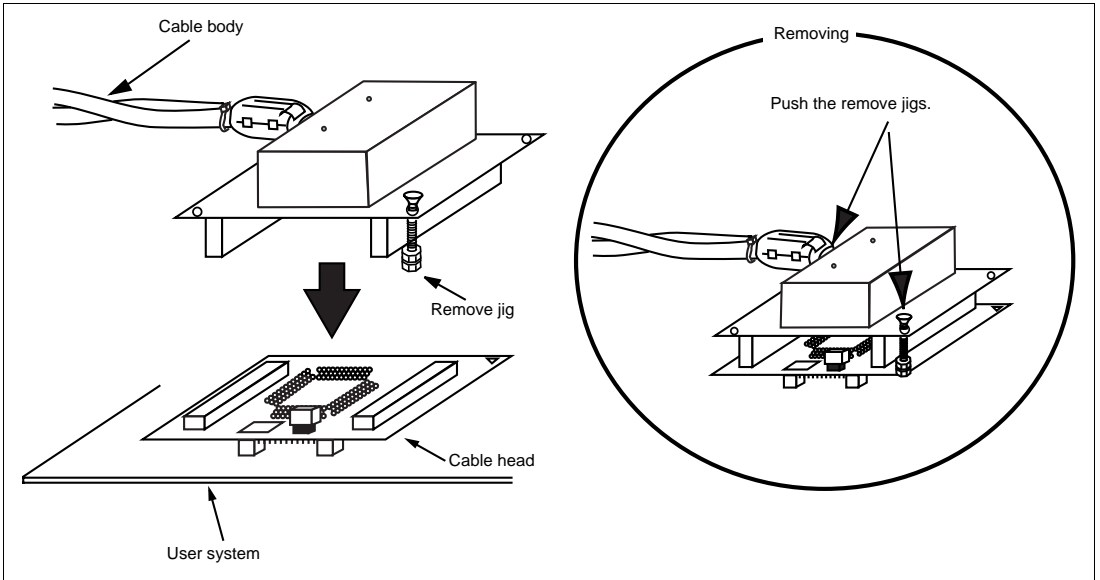

Figure 4 Fastening Cable Body

2.3 Recommended Dimensions for User System Mount Pad

Figure 5 shows the recommended dimensions for the mount pad (footprint) for the user system with an IC socket for an FP-100B/TFP-100B package (IC149-100-054-B51: manufactured by YAMAICHI ELECTRONICS Co., Ltd.). Note that the dimensions in figure 5 are somewhat different from those of the actual chip's mount pad.

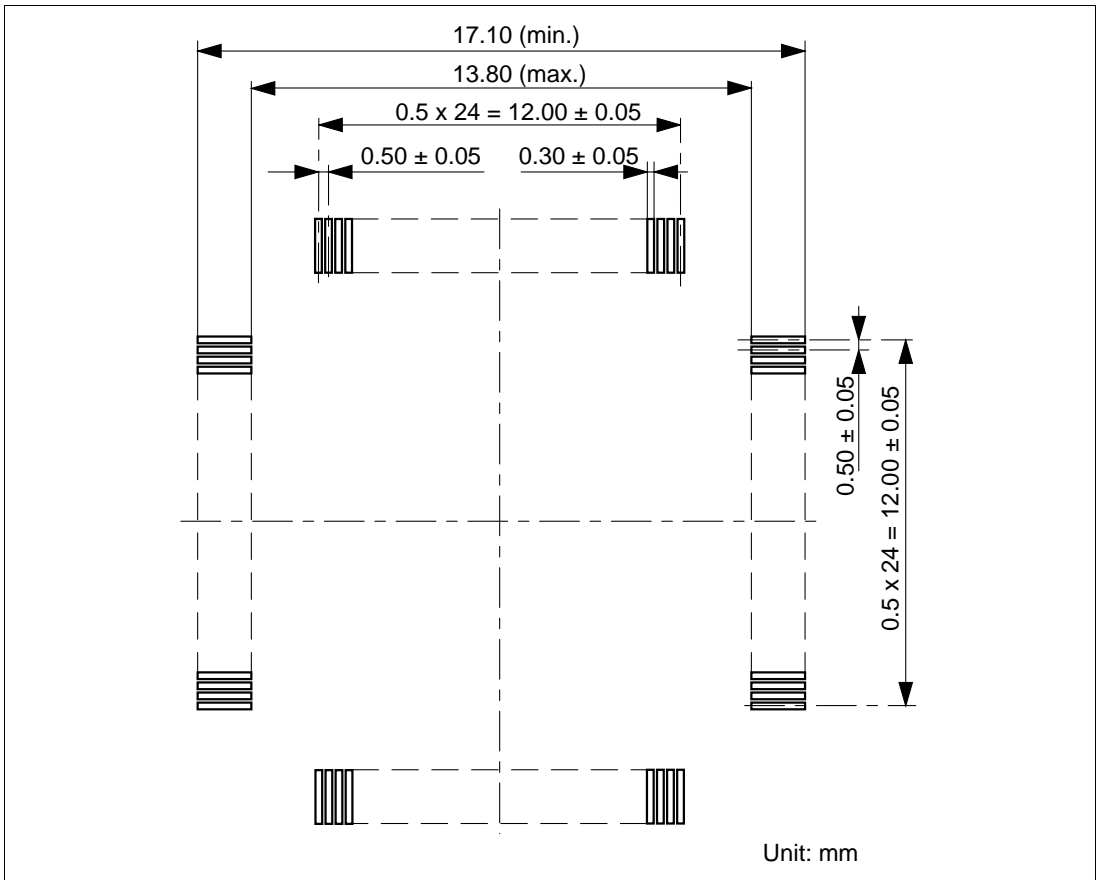

Figure 5 Recommended Dimensions for Mount Pad

2.4 Dimensions for User System Interface Cable Head

The dimensions for the user system interface cable head are shown in figure 6.

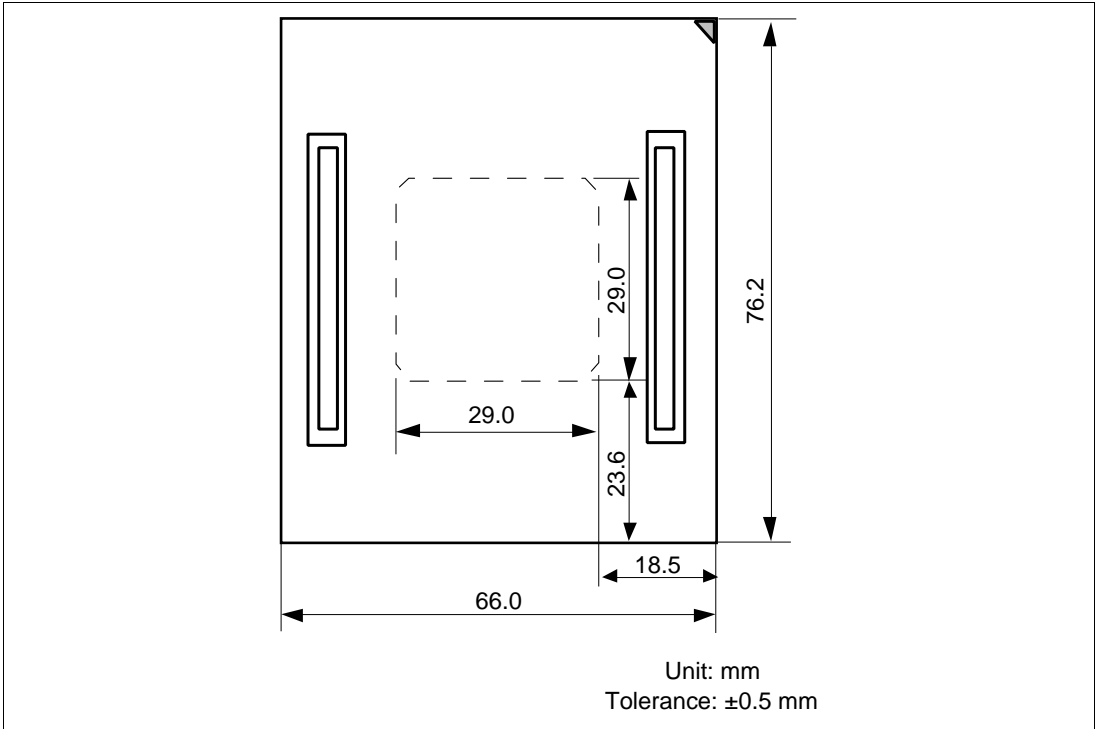

Figure 6 Dimensions for User System Interface Cable Head

2.5 Resulting Dimensions after Connecting User System Interface Cable

The resulting dimensions, after connecting the user system interface cable head to the user system, are shown in figure 7.

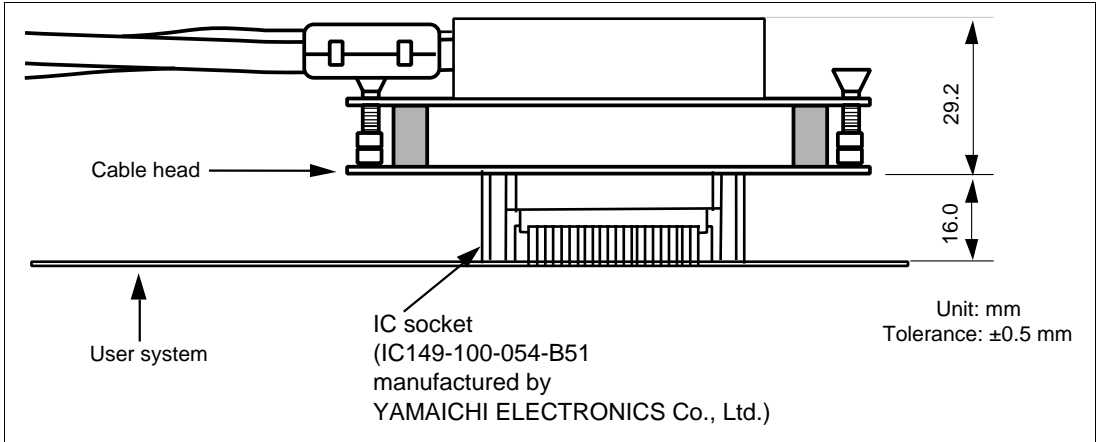

Figure 7 Resulting Dimensions after Connecting User System Interface Cable

Section 3 Installing the MCU to the User System

CAUTION

- 1. Check the location of pin 1 before inserting.**
- 2. Use a Philips-type screwdriver whose head matches the screw head.**
- 3. The tightening torque must be 0.294 N•m or less.
If the applied torque cannot be accurately measured, stop tightening when the force required to turn the screw becomes significantly greater than that needed when first tightening. If a screw is tightened too much, the screw head may break or an IC socket contact error may be caused by a crack in the IC socket solder.**
- 4. If the MCU does not operate correctly, cracks might have occurred in the solder. Check conduction with a tester and re-solder the IC socket if necessary.**

Check the location of pin 1 before inserting the MCU into the IC socket on the user system, as shown in figure 8. After inserting the MCU, fasten the socket cover with the provided four screws (M2.6 x 6 mm; with four flat washers). Take special care, such as manually securing the IC socket soldered area, to prevent the IC socket from being damaged by overtightening the screws or twisting the components.

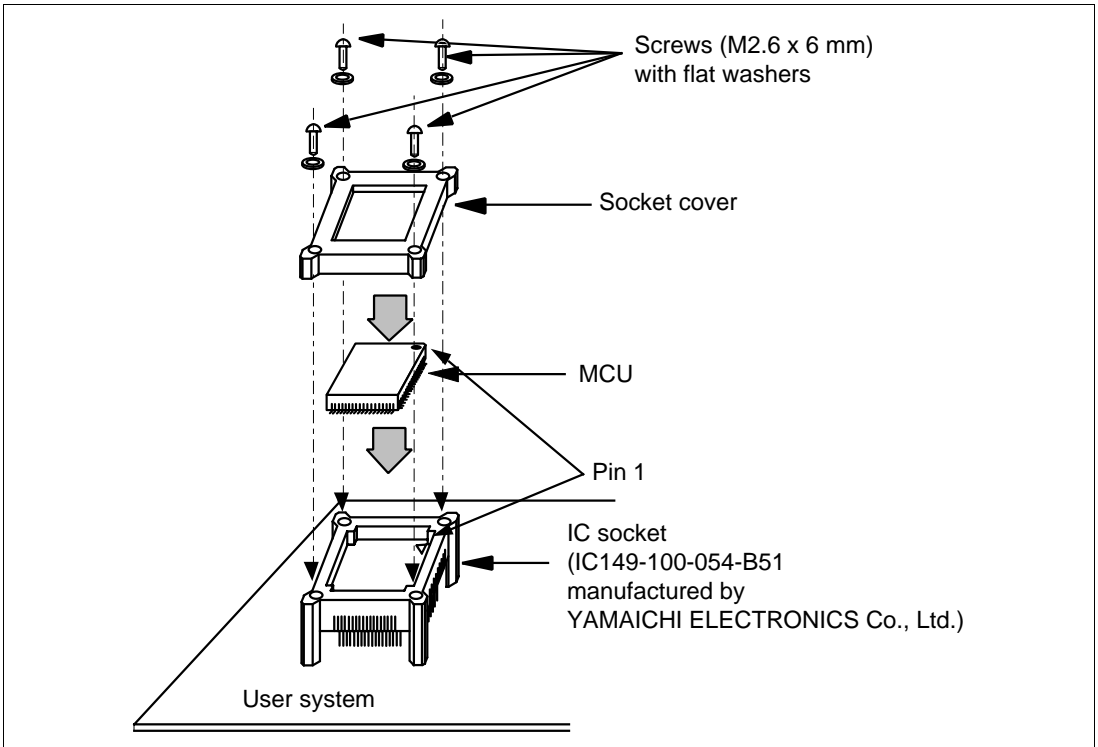

Figure 8 Installing MCU to User System

Section 4 Verifying Operation

1. Start up the emulator according to the procedures described in the H8/3048 Group, H8/3052 Group, H8/3062 Group, H8/3067 Group, H8/3007 Group E6000 Emulator User's Manual (HS3064BEPI61HE).
2. Verify the user system interface cable connections by accessing the external memory and ports to check the bus states of the pins with the MEMORY_FILL command (emulator command). If an error is detected, recheck the soldered IC socket and the location of pin 1.
3. The emulator connected to this user system interface cable supports two kinds of clock sources: an emulator internal clock and an external clock on user system. For details, refer to the H8/3048 Group, H8/3052 Group, H8/3062 Group, H8/3067 Group, H8/3007 Group E6000 Emulator User's Manual (HS3064BEPI61HE).
 - To use the emulator internal clock
 Select the clock in the emulator station as the system clock (ϕ) by using the CLOCK command (emulator command).
 - To use the external clock on the user system as the system clock
 Select target clock t or t2 with the CLOCK command (emulator command). Supply the external clock from the user system to the emulator by inputting the external clock from the EXTAL terminal on the cable head or connecting a crystal oscillator to the XTAL and EXTAL terminals. For details, refer to the section of Clock Pulse Generator, in the H8/3048 Group, H8/3052 Group, H8/3062 Group, H8/3067 Group, H8/3007 Group Hardware Manual.

Figure 9 shows the clock oscillator circuit on the user system interface cable.

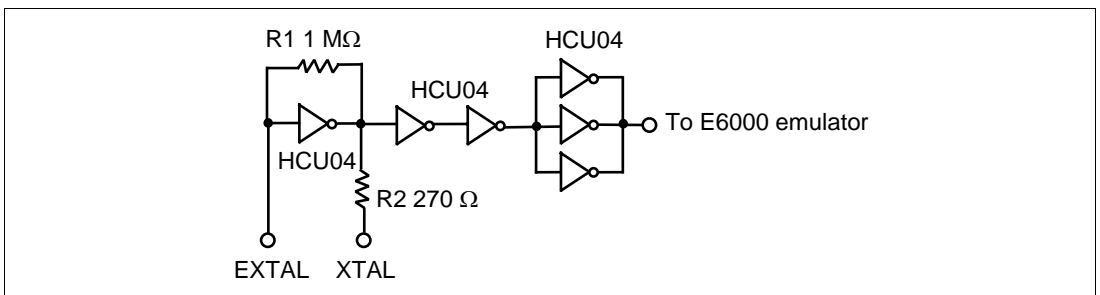

Figure 9 Clock Oscillator Circuit

Section 5 Notice

1. Make sure that pin 1 on the user system IC socket is correctly aligned with pin 1 on the cable head before inserting the cable head into the user system IC socket.
2. The dimensions of the recommended mount pad for the user system IC socket are different from those of the MCU.
3. This user system interface cable is specifically designed for the HS3064BEPI61H emulator. Do not use this cable with any other emulator station.
4. To prevent breaking of wires in the cable body, do not place heavy or sharp metal objects on the user system interface cable.
5. While the emulator station is connected to the user system with the user system interface cable, force must not be applied to the cable head. Place the emulator station, user system interface cable, and user system as shown in the example in figure 10.

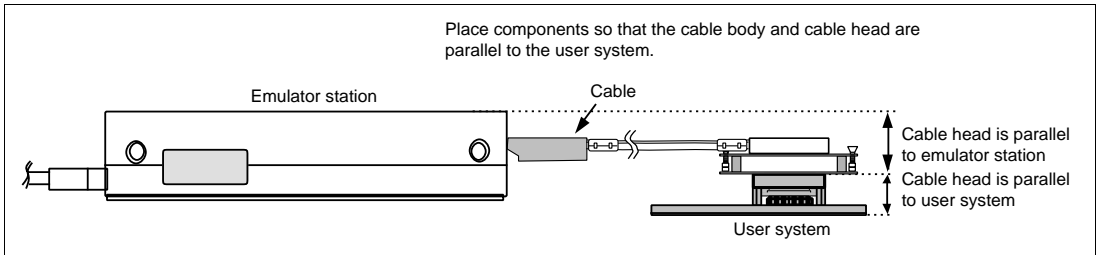

Figure 10 User System Interface Cable Location Example

6. The P1 jumper is used for testing. A jumper pin is inserted in pin 1 side. Do not remove the inserted jumper pin.

CAUTION

Insert the jumper pin in pin 3 side for P4 jumper when pin 10 of the MCU is not used as $\overline{\text{RESO}}$. Otherwise the user system interface cable, the emulator product, and the user system will be damaged.

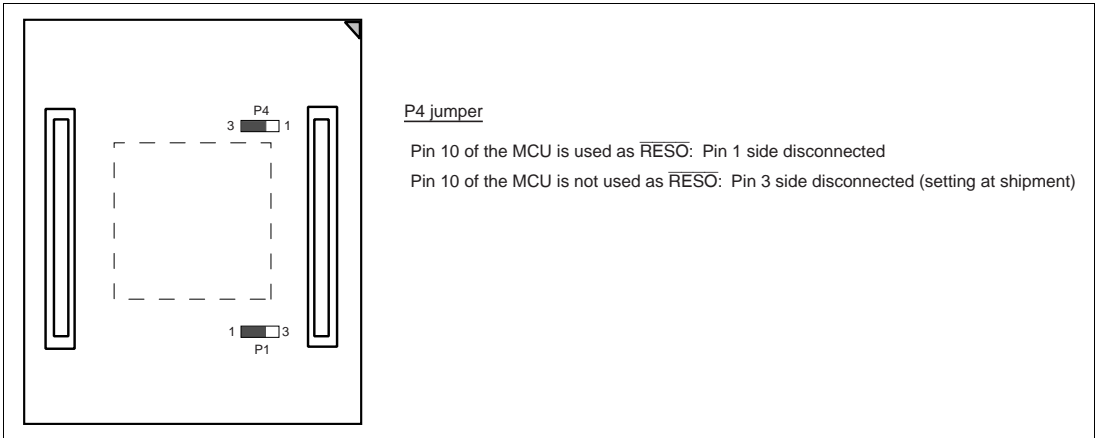

Figure 11 Jumper

**H8/3048 Group, H8/3052 Group, H8/3062 Group,
H8/3067 Group, H8/3007 Group FP-100B/TFP-100B
User System Interface Cable
for E6000 Emulator User's Manual**

Publication Date: Rev.3.00, March, 2003
Rev.4.00, August 20, 2008
Published by: Sales Strategic Planning Div.
Renesas Technology Corp.
Edited by: Customer Support Department
Global Strategic Communication Div.
Renesas Solutions Corp.

Renesas Technology Corp. Sales Strategic Planning Div. Nippon Bldg., 2-6-2, Ohte-machi, Chiyoda-ku, Tokyo 100-0004, Japan



RENESAS SALES OFFICES

<http://www.renesas.com>

Refer to "<http://www.renesas.com/en/network>" for the latest and detailed information.

Renesas Technology America, Inc.

450 Holger Way, San Jose, CA 95134-1368, U.S.A
Tel: <1> (408) 382-7500, Fax: <1> (408) 382-7501

Renesas Technology Europe Limited

Dukes Meadow, Millboard Road, Bourne End, Buckinghamshire, SL8 5FH, U.K.
Tel: <44> (1628) 585-100, Fax: <44> (1628) 585-900

Renesas Technology (Shanghai) Co., Ltd.

Unit 204, 205, AZIA Center, No.1233 Lujiazui Ring Rd, Pudong District, Shanghai, China 200120
Tel: <86> (21) 5877-1818, Fax: <86> (21) 6887-7858/7898

Renesas Technology Hong Kong Ltd.

7th Floor, North Tower, World Finance Centre, Harbour City, Canton Road, Tsimshatsui, Kowloon, Hong Kong
Tel: <852> 2265-6688, Fax: <852> 2377-3473

Renesas Technology Taiwan Co., Ltd.

10th Floor, No.99, Fushing North Road, Taipei, Taiwan
Tel: <886> (2) 2715-2888, Fax: <886> (2) 3518-3399

Renesas Technology Singapore Pte. Ltd.

1 Harbour Front Avenue, #06-10, Keppel Bay Tower, Singapore 098632
Tel: <65> 6213-0200, Fax: <65> 6278-8001

Renesas Technology Korea Co., Ltd.

Kukje Center Bldg. 18th Fl., 191, 2-ka, Hangang-ro, Yongsan-ku, Seoul 140-702, Korea
Tel: <82> (2) 796-3115, Fax: <82> (2) 796-2145

Renesas Technology Malaysia Sdn. Bhd

Unit 906, Block B, Menara Amcorp, Amcorp Trade Centre, No.18, Jln Persiaran Barat, 46050 Petaling Jaya, Selangor Darul Ehsan, Malaysia
Tel: <603> 7955-9390, Fax: <603> 7955-9510

H8/3048 Group, H8/3052 Group,
H8/3062 Group, H8/3067 Group,
H8/3007 Group FP-100B/TFP-100B
User System Interface Cable
for E6000 Emulator User's Manual



Renesas Technology Corp.

Free Manuals Download Website

<http://myh66.com>

<http://usermanuals.us>

<http://www.somanuals.com>

<http://www.4manuals.cc>

<http://www.manual-lib.com>

<http://www.404manual.com>

<http://www.luxmanual.com>

<http://aubethermostatmanual.com>

Golf course search by state

<http://golfingnear.com>

Email search by domain

<http://emailbydomain.com>

Auto manuals search

<http://auto.somanuals.com>

TV manuals search

<http://tv.somanuals.com>