

Panasonic

IP Proprietary Telephone

Quick Reference Guide

Model No. KX-NT265

Important Information

When using the KX-NT265, keep the following conditions in mind.

- If the unit does not operate properly, disconnect the unit from the Ethernet[®] cable and then connect again.
- If you are having problems making calls, unplug the Ethernet cable and connect a known working IP Proprietary Telephone (IP-PT). If the known working IP-PT operates properly, have the defective IP-PT repaired by an authorised Panasonic Factory Service Centre. If the known working IP-PT does not operate properly, check the Hybrid IP-PBX and the Ethernet cable.
- Wipe the unit with a soft cloth. Do not clean the unit with abrasive powders or with chemical agents such as benzene or thinner.
- Use only the correct Panasonic handset.
- Do not disassemble this unit. Dangerous electrical shock could result. The unit must only be disassembled and repaired by qualified service technicians.
- If damage to the unit exposes any internal parts, immediately disconnect the cable or cord. If the power is supplied from the network to the IP-PT [Power-over-Ethernet], disconnect the Ethernet cable. Otherwise, disconnect the AC adaptor cord. Then return this unit to a service centre.
- Never attempt to insert wires, pins, etc. into the vents or other holes of this unit.
- This unit is designed to aid the visually handicapped to locate dial keys and buttons.
- This unit is designed to be installed under controlled conditions of ambient temperature and a relative humidity.
- Avoid installing the unit in damp or humid environments, such as bathrooms or swimming pools.
- 999 and 112 can be dialled on the product after accessing the CO line for the purpose of making outgoing calls to the BT emergency (999) and (112) services (United Kingdom only).

Take special care to follow the safety suggestions listed below.

Safety

- 1) The unit should only be connected to a power supply of the type described in the Quick Reference Guide or as shown on the label on the unit.
- 2) When left unused for a long period of time, the optional AC adaptor should be unplugged from the AC outlet, if you are using Power-over-Ethernet, disconnect the Ethernet cable.

Installation

Environment

- 1) Do not use this unit near water, for example, near a bathtub, washbowl or sink. Damp basements should also be avoided.
- 2) Keep the unit away from heating appliances and devices that generate electrical noise, such as fluorescent lamps, motors and televisions. These noise sources can interfere with the performance of the unit. It also should not be placed in rooms where the temperature is less than 5 °C or greater than 40 °C.

Placement

- 1) Do not place heavy objects on top of this unit.
- 2) Care should be taken so that objects do not fall onto, and liquids are not spilled into, the unit. Do not subject this unit to excessive smoke, dust, moisture, mechanical vibration, shock or direct sunlight.
- 3) Place the unit on a flat surface.

Important Information

WARNING:

TO PREVENT POSSIBLE FIRE OR ELECTRIC SHOCK, DO NOT EXPOSE THIS UNIT TO RAIN OR MOISTURE.

THIS HANDSET EARPIECE IS MAGNETISED AND MAY RETAIN SMALL FERROUS OBJECTS.

UNPLUG THIS UNIT FROM POWER OUTLET/THE ETHERNET CABLE IF IT EMITS SMOKE, AN ABNORMAL SMELL OR MAKES UNUSUAL NOISE.

THESE CONDITIONS CAN CAUSE FIRE OR ELECTRIC SHOCK. CONFIRM THAT SMOKE HAS STOPPED AND CONTACT AN AUTHORISED SERVICE CENTRE.

IMPORTANT NOTICE:

- Under power failure conditions, the IP-PT may not operate. Please ensure that a separate telephone, not dependent on local power, is available for use in remote sites in case of emergency.
- For information regarding network setup of the IP-PT such as IP address, please refer to the Installation Manual for the Panasonic Hybrid IP-PBX.
- If an error message is shown on your display, consult the network administrator.
- The firmware of the KX-NT265 is protected by copyright laws and international treaty provisions, and all other applicable laws. It can not be reverse engineered, decompiled or disassembled.

This unit is capable of being used in conjunction with hearing aids fitted with inductive coil pick-ups. The handset should be held as for normal conversation. For operation, the hearing aid should be set to its "T" position or as directed in the operating instructions for the hearing aid.



Note:

In this manual, the suffix of each model number is omitted.

Trademark:

Ethernet is either a registered trademark or a trademark of Xerox Corporation in the United States and/or other countries.

This model supports the following PBX and IP-EXT card versions:









KX-TDA100/KX-TDA200: PMPR Software File Version 3.0000 or later



















































KX-TDA600: PLMPR Software File Version 3.0000 or later

KX-TDA0470(IP-EXT16): PIPEXT Software Version 1.001 or later/

PVOIPEX Software Version 1.011 or later

Features List

-  Outside (CO) Line button
  Off-hook
  On-hook
  Feature number
  Talk
 Incoming Call Distribution Group button
  Direct Station Selection button
 C. Tone Confirmation Tone
  R.B. Tone Ringback Tone



















Feature	Operation	
Making Calls		
Calling	To an extension  ► extension no. ► 	To an outside party  ►  ► outside phone no. ► 
Redial	 ► REDIAL ► 	
Quick Dialling	 ► quick dial no. ► 	
One-touch Dialling	To store  ►  ► 2 ► desired no. (max. 32 digits) ►  ► 	To dial  ►  assigned as a One-touch Dialling button ► 
	Operator Call	 ► 0 ► 
Personal Speed Dialling	To store  ► * 3 0 ► personal speed dial no. (2 digits) ► desired no. (max. 32 digits) ► #  	To dial  ►  ► * ► personal speed dial no. (2 digits) ► 
	System Speed Dialling	To dial  ►  ► system speed dial no. (3 digits) ► 
Doorphone Call	 ► * 3 1 ► doorphone no. (2 digits)  	
Automatic Callback Busy	To set 6  	To cancel  ► * 4 6  
	To answer from an idle extension <i>While hearing a callback ring</i>   	To answer from an idle outside line <i>While hearing a callback ring</i>  ► outside phone no. ► 
During a Conversation		
Call Hold	To hold   	To retrieve a call at the holding extension  ►  /  /  ► 
	To retrieve an outside call from another extension  ►  ► 	

Features List



























Feature	Operation
During a Conversation	
Call Transfer	<p>TRANSFER C. Tone</p> <p>[extension no. To an extension]</p> <p>[(CO) outside phone no. To an outside party]</p> <p>▶ ▶ </p>
Useful Features	
Off-hook Monitor	<p>To set/cancel <i>During a conversation using the handset</i></p> <p>SP-PHONE </p>
Call Park	<p>To set</p> <p>TRANSFER C. Tone</p> <p>[* 5 2] ▶ [parking zone no. (2 digits) Specified] </p> <p>[*] Auto C. Tone</p> <hr/> <p>To retrieve</p> <p> ▶ [* 5 2] ▶ [stored parking zone no. (2 digits)] C. Tone </p>
Multiple Party Conversation	<p>To add other parties during a conversation</p> <p> assigned as a CONFERENCE button [desired phone no.] ▶ ▶ assigned as a CONFERENCE button Talk with multiple parties.</p> <hr/> <p>To leave a conference</p> <p> assigned as a CONFERENCE button </p>
Call Pickup	<p> ▶ [(DSS)]</p> <p>[* 4 1] ▶ [extension no.] Directed</p> <p>[* 4 0] ▶ [group no. (2 digits)] Group</p> <p>C. Tone </p>
Sending a Call Waiting Tone	<p><i>While hearing a busy tone</i></p> <p>[1] ▶ Wait for an answer. ▶ </p>
Answering a Call Waiting	<p>To hold the current call then talk to the new party</p> <p>HOLD ▶ [(CO)] / INTERCOM * ▶ </p>

* Disregard this step if both parties are extensions.

Features List

Feature	Operation
Useful Features	
Paging	<p>To page</p>  → * 3 3 → paging group no. (2 digits) C. Tone  Announce. → Wait for an answer. C. Tone 
	<p>To answer</p>  → * 4 3 C. Tone 
	<p>To allow/deny a paged announcement</p>  → * 7 2 1 1 Deny * 7 2 1 0 Allow C. Tone 
Message Waiting	<p>Caller</p> <p>To leave a message waiting indication When the called extension is busy or does not answer</p> MESSAGE C. Tone 
	<p>Called extension</p> <p>To call back</p>  → MESSAGE → 
Log-in/Log-out	 → * 7 3 6 1 For Log-in * 7 3 6 0 For Log-out → ICD Group extension no. Specified  C. Tone  All
Before Leaving Your Desk	
Setting Absent Message	<p>To set</p>  → * 7 5 0 → message no. (1-9) → parameter (if required) → # → 
<p>To cancel</p>  → * 7 5 0 0 → 	
Call Forwarding	 → * 7 1 → 0 Both Calls 1 Outside Calls 2 Intercom Calls
<div style="border: 1px solid black; padding: 5px;"> <p>2 All calls</p> <p>3 Busy</p> <p>4 No answer</p> <p>5 Busy/ No answer</p> <p>0 Cancel</p> </div> <p style="text-align: center;">OR</p> <div style="border: 1px solid black; padding: 5px; display: flex; align-items: center;"> extension no. → CO line access no. → outside phone no. → # </div> <p style="text-align: right;">C. Tone </p>	

Features List

Feature	Operation													
Before Leaving Your Desk														
Extension Dial Lock	To lock  ► * 7 7 1  													
	To unlock  ► * 7 7 0 ► extension PIN (max. 10 digits)  													
Setting the Telephone According to Your Needs														
Do Not Disturb	 ► * 7 1 ► <table border="1" style="display: inline-table; vertical-align: middle;"> <tr><td>0</td><td>Both Calls</td></tr> <tr><td>1</td><td>Outside Calls</td></tr> <tr><td>2</td><td>Intercom Calls</td></tr> </table> ► <table border="1" style="display: inline-table; vertical-align: middle;"> <tr><td>1</td><td>Set</td></tr> <tr><td>0</td><td>Cancel</td></tr> </table>  	0	Both Calls	1	Outside Calls	2	Intercom Calls	1	Set	0	Cancel			
0	Both Calls													
1	Outside Calls													
2	Intercom Calls													
1	Set													
0	Cancel													
Extension Feature Clear	 ► * 7 9 0  													
Timed Reminder	To set  ► * 7 6 0 1 ► <table border="1" style="display: inline-table; vertical-align: middle; border-style: dashed;"> <tr><td>12 H</td></tr> <tr><td>hour/minute (4 digits)</td></tr> <tr><td>► <table border="1"><tr><td>0</td><td>AM</td></tr><tr><td>1</td><td>PM</td></tr></table></td></tr> <tr><td>24 H</td></tr> <tr><td>hour/minute (4 digits)</td></tr> </table> ► <table border="1" style="display: inline-table; vertical-align: middle;"> <tr><td>0</td><td>once</td></tr> <tr><td>1</td><td>daily</td></tr> </table>  	12 H	hour/minute (4 digits)	► <table border="1"><tr><td>0</td><td>AM</td></tr><tr><td>1</td><td>PM</td></tr></table>	0	AM	1	PM	24 H	hour/minute (4 digits)	0	once	1	daily
	12 H													
hour/minute (4 digits)														
► <table border="1"><tr><td>0</td><td>AM</td></tr><tr><td>1</td><td>PM</td></tr></table>	0	AM	1	PM										
0	AM													
1	PM													
24 H														
hour/minute (4 digits)														
0	once													
1	daily													
To cancel  ► * 7 6 0 0  														
To stop or answer the ring back  / 														
Receiving Call Waiting	To set/cancel for intercom calls  ► * 7 3 1 ► <table border="1" style="display: inline-table; vertical-align: middle;"> <tr><td>0</td><td>No Call</td></tr> <tr><td>1</td><td>Tone</td></tr> <tr><td>3</td><td>Whisper OHCA</td></tr> </table>  	0	No Call	1	Tone	3	Whisper OHCA							
	0	No Call												
1	Tone													
3	Whisper OHCA													
To set/cancel for outside calls  ► * 7 3 2 ► <table border="1" style="display: inline-table; vertical-align: middle;"> <tr><td>0</td><td>No tone</td></tr> <tr><td>1</td><td>Tone</td></tr> </table>  		0	No tone	1	Tone									
0	No tone													
1	Tone													



- Consult your dealer for more details about the feature numbers.
- You can change the flexible CO buttons to the feature buttons.
- "Location of Controls" is shown on page 7.

Location of Controls

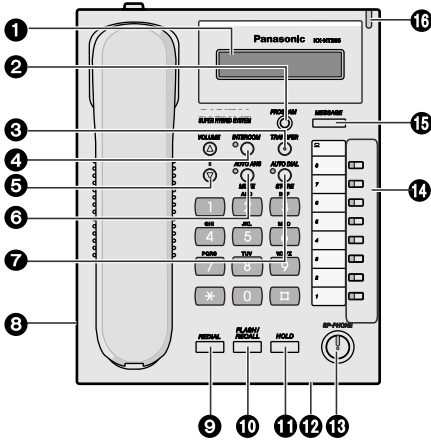

- 1 LCD (Liquid Crystal Display)**
- 2 PROGRAM:** Used to enter and exit the personal programming mode.
- 3 TRANSFER:** Used to transfer a call to another party.
- 4 INTERCOM:** Used to make or receive intercom calls.
- 5 VOLUME Control Button:** Used to adjust the volume.
- 6 AUTO ANS (Auto Answer)/MUTE:** Used to receive an incoming call in hands-free mode or mute the microphone/handset during a conversation.

- 7 AUTO DIAL/STORE:** Used for System/Personal Speed Dialling or storing programme changes.
- 8 Headset Jack**
- 9 REDIAL:** Used to redial the last dialled number.
- 10 FLASH/RECALL:** Used to disconnect the current call and make another call without hanging up.
- 11 HOLD:** Used to place a call on hold.
- 12 Microphone:** Used for the hands-free conversation.
- 13 SP-PHONE (Speakerphone):** Used for the hands-free operation.
- 14 Flexible Outside (CO) Line Buttons:** Used to make or receive an outside call. Pressing this button seizes an idle outside line automatically. (Button assignment is required.) Also used as feature buttons. (Button assignment is required.)
- 15 MESSAGE:** Used to leave a message waiting indication or call back the party who left the message waiting indication.
- 16 Message/Ringer Lamp:** When you receive a call, the lamp flashes red. When someone has left you a message, the lamp stays on red.

Setting

Ringer volume

While on-hook or receiving a call

▲ ▼

Press UP or DOWN.

Ring Tone

PROGRAM → [(CO) OR INTERCOM] → [0 1 *] → [0 8] → AUTO DIAL STORE → PROGRAM

Press Twice.

* The ring tone pattern of patterns 09 to 30 is the same as pattern 01.

LCD Contrast/Headset Mode

While on-hook

PROGRAM → [LCD Contrast 0 1 Headset Mode 6 1] → AUTO DIAL STORE → ▲ ▼ → AUTO DIAL STORE → PROGRAM

Press UP or DOWN.

Settings on the Programming Mode

To enter the programme mode		To exit	
PROGRAM ○		PROGRAM ○	
Operation			
Loop-CO (L-CO)	CO ► * ► <input type="radio"/> AUTO DIAL <input type="radio"/> STORE	FWD/DND - Both calls	CO ► 4 1 ► <input type="radio"/> AUTO DIAL <input type="radio"/> STORE
Single-CO (S-CO)	CO ► 0 CO line no. ► <input type="radio"/> AUTO DIAL <input type="radio"/> STORE	FWD/DND - Outside calls	CO ► 4 2 ► <input type="radio"/> AUTO DIAL <input type="radio"/> STORE
Direct Station Selection	CO ► 1 extension no. ► <input type="radio"/> AUTO DIAL <input type="radio"/> STORE	FWD/DND - Intercom calls	CO ► 4 3 ► <input type="radio"/> AUTO DIAL <input type="radio"/> STORE
One-touch Dialling	CO ► 2 desired no. ► <input type="radio"/> AUTO DIAL <input type="radio"/> STORE	Account	CO ► 4 8 ► <input type="radio"/> AUTO DIAL <input type="radio"/> STORE
Incoming Call Distribution Group (ICD Group)	CO ► 3 0 ► <input type="radio"/> AUTO DIAL ICD Group no. ► <input type="radio"/> STORE	Conference	CO ► 4 9 ► <input type="radio"/> AUTO DIAL <input type="radio"/> STORE
		Log-in/Log-out	CO ► 5 5 ► <input type="radio"/> AUTO DIAL <input type="radio"/> STORE
Preferred Line Assignment-Outgoing	1 9 ► <input type="radio"/> AUTO DIAL <input type="radio"/> STORE	<input type="radio"/> 0 No line <input type="radio"/> 1 An idle outside line <input type="radio"/> 2 + CO button no. / CO A CO/ICD Group button <input type="radio"/> 3 / INTERCOM <input type="radio"/> Intercom	► <input type="radio"/> AUTO DIAL <input type="radio"/> STORE
Preferred Line Assignment-Incoming	2 0 ► <input type="radio"/> AUTO DIAL <input type="radio"/> STORE	<input type="radio"/> 0 No line <input type="radio"/> 1 The longest ringing line <input type="radio"/> 2 + CO button no. / CO An assigned outside button	► <input type="radio"/> AUTO DIAL <input type="radio"/> STORE
Alternate Receiving-Ring/Voice	2 1 ► <input type="radio"/> AUTO DIAL <input type="radio"/> STORE	<input type="radio"/> 0 Ringing (Tone Call) <input type="radio"/> 1 Directly (Voice Call) <input type="radio"/> 2 Ring only	► <input type="radio"/> AUTO DIAL <input type="radio"/> STORE
Call Waiting for Outside calls	3 0 ► <input type="radio"/> AUTO DIAL <input type="radio"/> STORE	<input type="radio"/> 0 No (No tone) / <input type="radio"/> 1 Yes (Tone)	► <input type="radio"/> AUTO DIAL <input type="radio"/> STORE
Call Waiting Selection	3 1 ► <input type="radio"/> AUTO DIAL <input type="radio"/> STORE	<input type="radio"/> 0 No Call / <input type="radio"/> 1 Tone / <input type="radio"/> 3 Whisper OHCA	► <input type="radio"/> AUTO DIAL <input type="radio"/> STORE
Call Waiting Tone Type Selection	3 2 ► <input type="radio"/> AUTO DIAL <input type="radio"/> STORE	<input type="radio"/> 0 Tone 1 / <input type="radio"/> 1 Tone 2	► <input type="radio"/> AUTO DIAL <input type="radio"/> STORE
Extension PIN [Personal Identification Number] (PIN-max.10 digits)	9 0 ► <input type="radio"/> AUTO DIAL <input type="radio"/> STORE	To set an extension PIN	extension PIN ► <input type="radio"/> AUTO DIAL <input type="radio"/> STORE ► same PIN
		To change a stored extension PIN to new one	stored extension PIN ► new PIN ► <input type="radio"/> AUTO DIAL <input type="radio"/> STORE ► same PIN
Station Programming Data Default Set	# # ► <input type="radio"/> AUTO DIAL <input type="radio"/> STORE		► <input type="radio"/> AUTO DIAL <input type="radio"/> STORE

Tilt Angle

The tilt angle of the unit can be adjusted.

To adjust the angle, insert the stand into the desired holes as shown below.

< LOW >

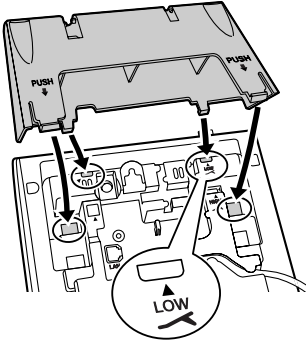
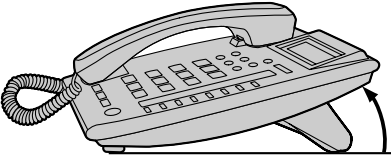

< HIGH >

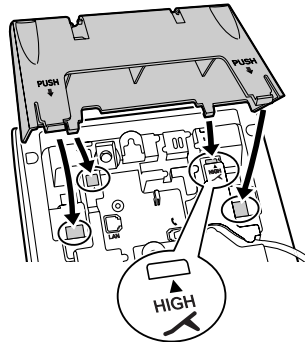
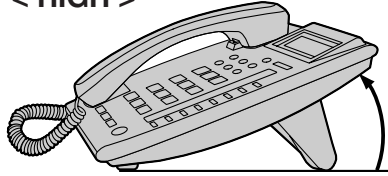

Connection

CAUTION

Ensure the cords are inserted in the grooves to prevent damage to the connector. Some thick cables may not fit in the grooves.

→ To a Switching Hub (LAN).

Ethernet cable (Straight CAT 5 or higher cable) [not included]

→ To the optional AC adaptor (not included).
USE ONLY WITH Panasonic AC ADAPTOR. *

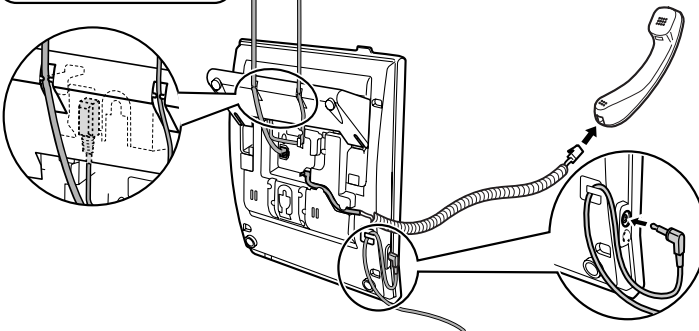

CAUTION

Ensure the headset cord is inserted in the hook to prevent damage to the connector.

< Back view >

Headset Jack

Headset (not included)

Do not use a KX-T7090 headset

Connection

*AC adaptor Order No.

United Kingdom: **KX-A237E** (PQLV1E)/Greece: **KX-A237CE** (PQLV1CE)

CAUTION:

The AC adaptor is used as the main disconnect device. Ensure that the AC outlet is located near the unit and is easily accessible.

Note:

Consult your dealer for more details about the AC adaptor.

Wall Mounting

- 1** Pull down the handset hook until it locks, so the tab holds the handset.

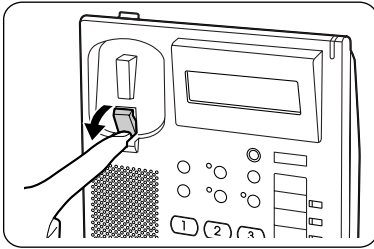

- 2** Remove the attached stand.

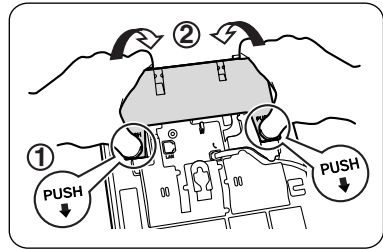

- 3** Mount the unit on the wall.

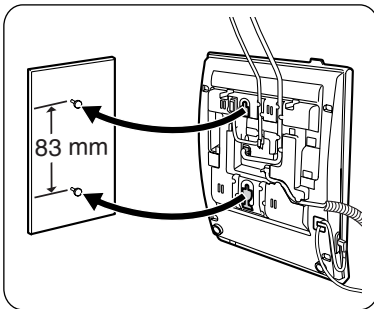

To temporarily place the handset down during a conversation, hook it over the top edge of the phone as shown.

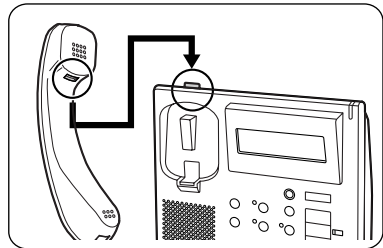

Wall Mounting

- ◆◆ If you are using the Ethernet cable with boots, you can mount the unit on a wall using the wall mounting plate (included) by following the steps below.

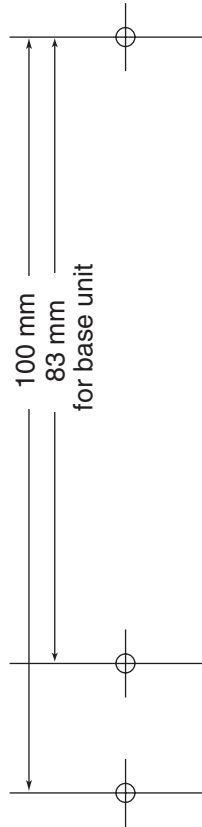
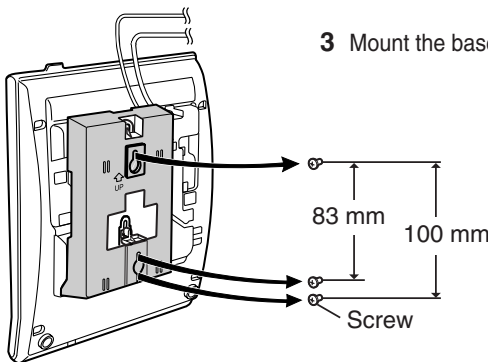
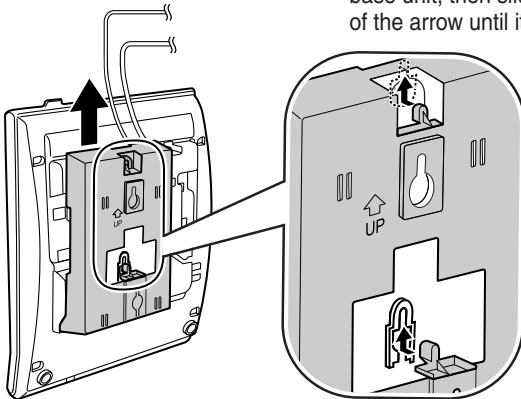
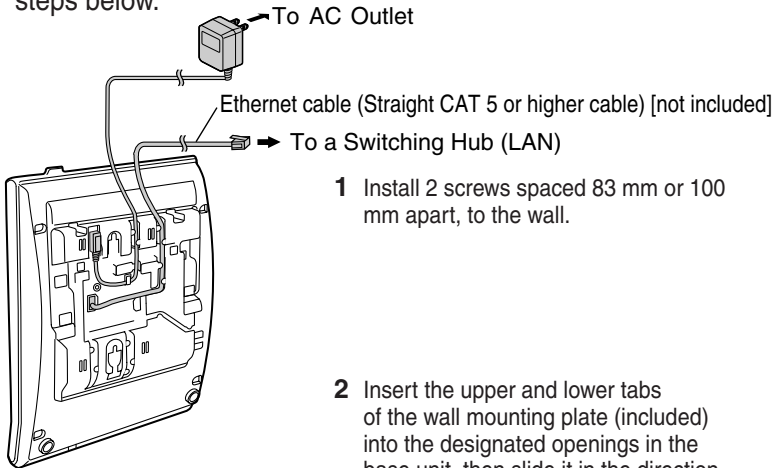

Information

Information on Disposal for Users of Waste Electrical & Electronic Equipment (private households)



This symbol on the products and/or accompanying documents means that used electrical and electronic products should not be mixed with general household waste.

For proper treatment, recovery and recycling, please take these products to designated collection points, where they will be accepted on a free of charge basis. Alternatively, in some countries you may be able to return your products to your local retailer upon the purchase of an equivalent new product.

Disposing of this product correctly will help to save valuable resources and prevent any potential negative effects on human health and the environment which could otherwise arise from inappropriate waste handling. Please contact your local authority for further details of your nearest designated collection point.

Penalties may be applicable for incorrect disposal of this waste, in accordance with national legislation.

For business users in the European Union

If you wish to discard electrical and electronic equipment, please contact your dealer or supplier for further information.

Information on Disposal in other Countries outside the European Union

This symbol is only valid in the European Union.

If you wish to discard this product, please contact your local authorities or dealer and ask for the correct method of disposal.



This product is intended to be connected to a Panasonic Hybrid IP-PBX only. Panasonic Communications Company (U.K.) Ltd. declares that this equipment is in compliance with the essential requirements and other relevant provisions of Radio & Telecommunications Terminal Equipment (R&TTE) Directive 1999/5/EC. Declarations of Conformity for the relevant Panasonic products described in this manual are available for download by visiting: <http://www.doc.panasonic.de>

Contact:

Panasonic Services Europe
a Division of Panasonic Marketing Europe GmbH
Panasonic Testing Centre
Winsbergring 15, 22525 Hamburg, Germany

Copyright:

This material is copyrighted by Panasonic Communications Co., Ltd., and may be reproduced for internal use only. All other reproduction, in whole or in part, is prohibited without the written consent of Panasonic Communications Co., Ltd.

©2006 Panasonic Communications Co., Ltd. All Rights Reserved.

Panasonic Communications Company (U.K.) Ltd.

Pencarn Way, Duffryn, Newport, South Wales, NP10 8YE, United Kingdom

Free Manuals Download Website

<http://myh66.com>

<http://usermanuals.us>

<http://www.somanuals.com>

<http://www.4manuals.cc>

<http://www.manual-lib.com>

<http://www.404manual.com>

<http://www.luxmanual.com>

<http://aubethermostatmanual.com>

Golf course search by state

<http://golfingnear.com>

Email search by domain

<http://emailbydomain.com>

Auto manuals search

<http://auto.somanuals.com>

TV manuals search

<http://tv.somanuals.com>