



# Alswitch™ Hardware Manual

Part Number AIHM

© 2008 by Kentrox, Inc. All rights reserved.

Copyright © 2008 by Kentrox, Inc. All Rights Reserved. The material discussed in this publication is the proprietary property of Kentrox, Inc. Kentrox retains all rights to reproduction and distribution of this publication.

Kentrox is a registered trademark of Kentrox, Inc. Applied Innovation, Applied Innovation Inc., the AI logo, and other names are the intellectual property of Kentrox. All other product names are trademarks or registered trademarks of their respective owners.

Information published here is current as of this document's date of publication, but is subject to change without notice. You may verify product information by contacting our headquarters in Oregon. Kentrox is an Equal Opportunity/Affirmative Action employer.

Kentrox, Inc.  
5800 Innovation Dr.  
Dublin, Ohio USA 43016-3271  
Toll Free: (800) 247-9482  
International: +1 (614) 798-2000  
Fax: +1 (614) 798-1770

20010 NW Tanasbourne Dr.  
Hillsboro, Oregon USA 97124-7104  
Toll Free: (800) 733-5511  
Direct: (503) 643-1681

# Contents

<b>Chapter 1: Introduction .....</b>	<b>1-1</b>
Documentation Overview .....	1-1
Training Information .....	1-3
Contact Information .....	1-4
Related Documentation .....	1-5
Document Registration .....	1-7
Text Conventions .....	1-8
<b>Chapter 2: Site Requirements .....</b>	<b>2-1</b>
AI180 Clearance Requirements .....	2-1
AI180 Environmental Requirements .....	2-2
AI130 Clearance Requirements .....	2-3
AI130 Environmental Requirements .....	2-3
<b>Chapter 3: AI180 Hardware Overview .....</b>	<b>3-1</b>
Overview .....	3-1
AISwitch Interconnectivity .....	3-2
AISwitch Series 180 Chassis Components .....	3-3
AISwitch Series 180 Chassis .....	3-4
AI180 Backplane .....	3-6
Craft Port Connection .....	3-6
RDC180-C Common Alarm Panel .....	3-7
Mounting Ears .....	3-7
Heat Deflection Baffle .....	3-8
AI198 Common Logic Card .....	3-8
AI182 Expander Card .....	3-9
AI183 and AI185 Asynchronous Line Cards .....	3-9
AI192 and AI196-X X.25 Interface Cards .....	3-10
AI196-ETS Gateway Interface Card .....	3-11
AI196-I Gateway Interface Cards .....	3-11
AI193-TX Ethernet Gateway Card .....	3-12
AI193-ES Ethernet OSI Interface End System .....	3-12
AI194 Ethernet Hub Card .....	3-12
AI294 Ethernet Switch .....	3-13
AI2524 Multi-Protocol Router Card .....	3-14
Power Supplies .....	3-15
RDC180-P Power Supply .....	3-15
RDC180-HP Revision B Power Supply .....	3-16
AI325-AC Power Supply .....	3-17
I710 Fuse Panel .....	3-17
AICOOL-48 Fan Unit .....	3-19
Distribution Panels .....	3-20

Other Vendor Components.....	3-21
Network Equipment Building Standards.....	3-21
<b>Chapter 4: AISwitch Series 180 Chassis Assembly .....</b>	<b>4-1</b>
Overview .....	4-1
Electrostatic Warning .....	4-1
Unpacking.....	4-1
Installing the AISwitch Series 180 Chassis.....	4-4
Replacing the AISwitch Series 180 Chassis.....	4-6
Installing the Heat Baffle.....	4-7
Replacing the Heat Baffle.....	4-9
Installing/Replacing Nylon Card Glides.....	4-10
Installing/Replacing the Craft Port Connection.....	4-11
How to Install the Craft Port Cable .....	4-11
How to Replace the Backplane/Craftport Assembly.....	4-11
Replacing the Backplane .....	4-12
Backplane Jumper Settings.....	4-14
Removing the Backplane.....	4-15
Replacing the Backplane .....	4-16
Installing the AI198 Common Logic Card.....	4-17
Installing/Replacing a Network Interface Card.....	4-18
Replacing an Asynchronous Card .....	4-19
Replacing a Smart Line Card.....	4-19
<b>Chapter 5: AI130 Hardware Overview .....</b>	<b>5-1</b>
Overview .....	5-1
RDC180-P Power Supply.....	5-2
AI325-AC Power Supply.....	5-3
RDC130-C Common Alarm Panel.....	5-4
Input Connections.....	5-4
Output Connections.....	5-4
Alarm Indicators.....	5-4
Grounding Panel.....	5-5
AI198 Common Logic Controller .....	5-6
Network Interface Card Slots 1 Through 3 .....	5-7
<b>Chapter 6: AISwitch Series 130 Chassis Assembly .....</b>	<b>6-1</b>
Overview .....	6-1
Electrostatic Warning .....	6-1
Unpacking.....	6-2
Rack Mounting .....	6-4
Installing the AI198 Common Logic Card.....	6-5
Installing Network Interface Cards.....	6-6
Replacing an Asynchronous Card .....	6-6
Replacing a Smart Line Card.....	6-6
Connecting a Terminal .....	6-7

<b>Chapter 7: Interface Card Hardware Specifications .....</b>	<b>7-1</b>
AI120 .....	7-1
AI120-64SA Power Supply .....	7-1
AI120-64IF Faceplate and Connectors .....	7-2
AI120-64SA Enclosure .....	7-3
AI182 .....	7-4
AI182 Faceplate and Connectors .....	7-4
AI183 .....	7-5
AI183 Faceplate and Connectors .....	7-5
Technical Specifications .....	7-5
AI185 .....	7-6
AI185 Faceplate and Connectors .....	7-6
Technical Specifications .....	7-6
AI192 .....	7-7
AI192-XR4 and AI192-XE4 Faceplate and Connectors .....	7-7
AI192-XV1 Faceplate and Connectors .....	7-8
AI192-XT2 Faceplate and Connectors .....	7-9
AI192 Revision 4 Jumper Settings .....	7-10
AI192 Revision 4 Board Layout .....	7-11
AI192 Revision 5 Jumper Settings .....	7-12
AI192 Revision 5 Board Layout .....	7-13
B004 Daughterboard Jumper Settings .....	7-14
B004 Daughterboard Layout .....	7-14
B005 Daughterboard Jumper Settings .....	7-15
B005 Daughterboard Layout .....	7-15
B009 Daughterboard Jumper Settings .....	7-16
B009 Daughterboard Layout .....	7-16
B010 Daughterboard Jumper Settings .....	7-17
B010 Daughterboard Layout .....	7-18
AI193-ES .....	7-19
Firmware .....	7-19
AI193-ES Faceplate and Connectors .....	7-19
AI193-ES Jumper Settings .....	7-20
AI193-ES Connectors .....	7-22
AI193-ES Revision 2.1 Card Layout .....	7-24
AI193-FT .....	7-25
AI193-FT Faceplate .....	7-25
AI193-FT Jumper Settings .....	7-26
AI193-FT Connectors .....	7-27
AI193-FT Revision A Card Layout .....	7-30
AI193-TX .....	7-31
AI193-TX Faceplate and Connectors .....	7-31
AI193-TX Jumper Settings .....	7-32
AI193-TX Connectors .....	7-33
AI193-TX Revision 2 Card Layout .....	7-37

AI194 .....	7-38
IRB Enable/Disable .....	7-38
AI194 Faceplate and Connectors .....	7-39
AI194 Jumper Settings .....	7-40
AI194 Connectors .....	7-41
AI194 Revision 4 Card Layout .....	7-42
AI196-ETS .....	7-43
AI196-ETS Faceplate and Connectors .....	7-43
AI196-ETS Jumper Settings .....	7-44
Power Supply/Cooling Requirements .....	7-44
B014 Daughterboard .....	7-45
B016 Daughterboard Jumper Settings .....	7-45
B055 Daughterboard Jumper Settings .....	7-45
B055 Daughterboard Layout .....	7-46
AI196-ETS Revision 5 Card Layout .....	7-47
AI196-I .....	7-48
Requirements .....	7-48
AI196-I Faceplate and Connectors .....	7-49
AI196-I Revision 5 Jumper Settings .....	7-50
AI196-I Revision 5 Card Layout .....	7-51
B014 Daughterboard Layout .....	7-52
B016 Daughterboard Jumper Settings .....	7-52
B016 Daughterboard Layout .....	7-53
B017 Daughterboard Jumper Settings .....	7-54
B017 Daughterboard Layout .....	7-55
B032 Daughterboard Jumper Settings .....	7-56
B032 Daughterboard Layout .....	7-57
AI196-IEGB .....	7-58
Power Supply/Cooling Requirements .....	7-58
AI196-IEGB Faceplate and Connectors .....	7-59
AI196-IEGB Jumper Settings .....	7-60
B014 Daughterboard Layout .....	7-61
B017 Daughterboard Jumper Settings .....	7-61
B014 Daughterboard Layout .....	7-62
B017 Daughterboard Layout .....	7-63
AI196-IEGB Revision 3 Card Layout .....	7-64
AI196-X .....	7-65
AI196 X.25 Protocol Overview .....	7-65
AI196 Multi-Protocol Overview .....	7-65
AI196-X Faceplate and Connectors .....	7-66
AI196-X Revision 3 Jumper Settings .....	7-67
AI196-X Revision 3 Card Layout .....	7-68
AI196-X Revision 5 Jumper Settings .....	7-69
AI196-X Revision 5 Card Layout .....	7-70
B016 Daughterboard Jumper Settings .....	7-71
B016 Daughterboard Layout .....	7-72
B017 Daughterboard Jumper Settings .....	7-73
B017 Daughterboard Layout .....	7-74

	B032 Daughterboard Jumper Settings.....	7-75
	B032 Daughterboard Layout.....	7-76
AI198	AI198.....	7-77
	AI198 Revision 1.....	7-77
	AI198 Revision 1 Faceplate and Connectors.....	7-78
	AI198 Revision 1 Jumper Settings.....	7-78
	AI198 Revision 1 Card Layout.....	7-80
	AI198 Revision 4a.....	7-81
	AI198 Revision 4a Faceplate and Connectors.....	7-82
	AI198 Revision 4a Jumper Settings.....	7-83
	AI198 Revision 4a Card Layout.....	7-85
AI285	AI285.....	7-86
	Typical Applications.....	7-86
	AI285 Hardware Components.....	7-86
	Technical Specifications.....	7-87
AI294	AI294.....	7-88
	Purpose.....	7-88
	Features.....	7-88
	AI294 Faceplate and Connectors.....	7-89
	Technical Specifications.....	7-90
	AI294 Physical Interfaces.....	7-92
AI296	AI296.....	7-93
	Typical Applications.....	7-93
	AI296 Hardware Components.....	7-93
	Technical Specifications.....	7-94
AI2524	AI2524.....	7-95
	Power Requirements.....	7-95
	AI2524 Faceplate and Connectors (base card).....	7-96
	AI2524 Jumper Settings.....	7-97
	AI2524 T1 CSU/DSU Faceplate and Connectors.....	7-97
	AI2524 4-wire 56K CSU/DSU Faceplate and Connectors.....	7-98
	AI2524 5-IN1 Faceplate and Connectors.....	7-99
	AI2524 ISDN/BRI Faceplate and Connectors.....	7-100
<b>Chapter 8: RDC180-P Power Supply.....</b>		<b>8-1</b>
	Overview.....	8-1
	RDC180-P Technical Specifications.....	8-2
	Connecting DC Power.....	8-4
	Installing a DC Power Supply.....	8-5
	Replacing a DC Power Supply.....	8-6
	Replacing the RDC180-P Fuse.....	8-7
	Replacing the 5 Amp Fuse.....	8-7
	RDC180-P Power Connector.....	8-8
	RDC180-P Input Power Wiring.....	8-9
	Single Source Connection.....	8-9
	Connecting Fused Power Wires.....	8-10
	Adjusting Voltage.....	8-11

<b>Chapter 9: RDC180-HP Power Supply Revision B .....</b>	<b>9-1</b>
Overview .....	9-1
RDC180-HP Technical Specifications .....	9-2
RDC180-HP Faceplate Description .....	9-3
RDC180-HP Internal and External Fuses .....	9-4
Internal Fuse .....	9-4
External Fuse .....	9-4
RDC180-HP Jumper Settings .....	9-5
Load Sharing .....	9-5
Hot Swap Operation .....	9-5
RDC180-HP Power Connectors .....	9-6
RDC180-HP Input Power Wiring .....	9-7
Normal Redundant Power Supply Connection .....	9-8
Double Redundancy Connections Using Four Fuse Panel Positions .....	9-9
Replacing a DC Power Supply .....	9-10
Installing Fully Redundant DC Power Supplies .....	9-13
Installation of Fully Redundant Revision A and Revision B Power Supplies .....	9-14
Installation of Fully Redundant Revision B Power Supplies .....	9-16
Connecting Fused Power Wires .....	9-18
<b>Chapter 10: AI325-AC Power Supply .....</b>	<b>10-1</b>
Overview .....	10-1
AI325-AC Technical Specifications .....	10-2
AI325-AC Panel Faceplate .....	10-4
AI325-AC Faceplate Description .....	10-5
Input Power Connectors .....	10-5
AI325-AC Power Cord .....	10-5
Voltage Adjustment Procedure .....	10-6
Adding Cards to an AI325-AC System .....	10-7
Power Supply Fuses .....	10-8
AI325-AC Fuses .....	10-8
How to Replace the 10 Amp Fuses .....	10-8
Jumper Settings .....	10-8
Installing/ Replacing an AI325-AC Power Supply .....	10-9
Upgrading to an AI325-AC Power Supply .....	10-10
Testing the Unit .....	10-12
<b>Chapter 11: RDC180-C Common Alarm Panel .....</b>	<b>11-1</b>
Overview .....	11-1
RDC180-C Common Alarm Panel Description .....	11-2
Connections .....	11-3
Input Connections .....	11-3
Output Connections .....	11-3
Grounding .....	11-3
Wrist Strap .....	11-3
Alarm Indicators .....	11-4
Software-Related Alarms .....	11-6
Installing an RDC180-C Common Alarm Panel .....	11-6



Replacing an RDC180-C Common Alarm Panel .....	11-7
<b>Chapter 12: RDC130-C Common Alarm Panel.....</b>	<b>12-1</b>
Overview .....	12-1
RDC130-C Common Alarm Panel Description .....	12-2
Connections .....	12-3
Output Connections .....	12-3
RDC130-C Alarm Indicators.....	12-4
Software-Related Alarms .....	12-6
Installing/Replacing an RDC130-C Common Alarm Panel.....	12-7
<b>Chapter 13: I710 Fuse Panel.....</b>	<b>13-1</b>
Overview .....	13-1
Cabled Side Connections.....	13-2
Noncabled Side Connections.....	13-3
Technical Specifications.....	13-4
Fuse Panel Operation.....	13-5
Complete Circuit Fuse.....	13-5
Fuse Alarm .....	13-5
Bay Major and Minor Alarms .....	13-5
Redundant Power Source .....	13-5
GMT Fuses .....	13-5
How to Install the I710 Fuse Panel.....	13-6
Testing and Maintaining the Fuse Panel.....	13-8
Testing the Fuse Panel.....	13-8
Maintaining the Fuse Panel .....	13-8
Installation of Equipment to the I710 Fuse Panel.....	13-9
How to Replace the I710 Fuse Panel.....	13-10
<b>Chapter 14: AICOOL-48 Fan Unit.....</b>	<b>14-1</b>
AICOOL-48 Overview .....	14-1
AICOOL-48 Technical Specifications .....	14-2
AICOOL-48 Components.....	14-3
AICOOL-48 Main Housing Section.....	14-4
AICOOL-48 Fan Tray Section .....	14-5
Light Indicator Panel .....	14-5
AICOOL-48 Terminal Block Connectors .....	14-7
AICOOL-48 Jumper Settings .....	14-8
AICOOL-48 Filter Section.....	14-9
Temperature Sensor .....	14-10
Installing the Temperature Sensor.....	14-10
Activating the Temperature Sensor .....	14-11
Heat Baffle.....	14-12
Installing the Heat Baffle.....	14-12
Installing the AICOOL-48 Fan Unit.....	14-13
Replacing/Maintaining the AICOOL-48 Fan Components.....	14-15
Replacing/Maintaining the Filter.....	14-15
Replacing Fuses.....	14-15

Replacing/Maintaining the Fan Tray .....	14-15
AICOOL-48 Light Indicator Troubleshooting Guide .....	14-16
<b>Chapter 15: Distribution Panels .....</b>	<b>15-1</b>
Overview .....	15-1
D Ring Cable Management .....	15-2
Installing a Distribution Panel .....	15-3
Replacing a Distribution Panel .....	15-4
DP120 Overview .....	15-5
DP120A .....	15-6
Overview .....	15-6
Unpowered Contact Closure to Ground .....	15-6
Actively Powered Signal .....	15-6
DP120A Faceplate and Connectors .....	15-7
DP120A Installation Notes .....	15-8
Connector Pin Assignments .....	15-12
DP185 Overview .....	15-17
DP185B Overview .....	15-18
DP185-RJ45 Overview .....	15-19
DP194 Overview .....	15-20
DP196 Overview .....	15-21
I709 Overview .....	15-22
I711 Overview .....	15-23
<b>Appendix A: Static Electricity (ESD).....</b>	<b>A-1</b>
Overview .....	A-1
Static Control .....	A-3
Wrist Strap Grounding .....	A-4
Setting Up Equipment/Performing Maintenance .....	A-5
<b>Appendix B: Calculating Chassis Power Consumption .....</b>	<b>B-1</b>
Overview .....	B-1
Power Supplies Available .....	B-1
Internal Power Ratings .....	B-2
Power Consumption Calculation .....	B-3
Shorthand Calculation Method .....	B-3
Input Amps/Watts Calculation Method .....	B-4
Internal Power Rating to Watts Formula .....	B-4
Low Line Current Draw Formula .....	B-5
Normal Current Draw Formula .....	B-5
High Line Current Draw Formula .....	B-5
Safety Factor Formula .....	B-5

# Chapter 1: Introduction

## Documentation Overview

This manual documents the use and operation of the AISwitch Series 180 hardware bay and AISwitch Series 130 hardware bay mountable units in an AISwitch system. This manual informs field installers, system managers, central office technicians, field engineers, and communication engineers how to install, maintain, or replace the AISwitch Series 180 and 130 hardware equipment.

The topics covered in this manual include

**Chapter #1:** [Introduction](#)

Includes purpose of the manual, projected audience, overview of the contents of this manual, related documentation, and text conventions used in this manual

**Chapter #2:** [Site Requirements](#)

Includes clearance and environmental requirements necessary to prepare the site prior to installation of the AISwitch Series 180 and AISwitch Series 130

**Chapter #3:** [AI180 Hardware Overview](#)

Includes general description of the components included in the AISwitch 180 chassis and additional equipment available for the bay

**Chapter #4:** [AISwitch Series 180 Chassis Assembly](#)

This component lists how to install or replace the AISwitch Series 180 chassis, mounting ears, heat deflection baffle, AI198, and interface cards along with component location and technical specifications.

**Chapter #5:** [AI130 Hardware Overview](#)

Includes general description of the components included in the AISwitch 130 chassis and additional equipment available for the bay

**Chapter #6:** [AISwitch Series 130 Chassis Assembly](#)

Includes description of a typical chassis shipment, location of chassis components and installation and replacement of chassis components

- Chapter #7:** [Interface Card Hardware Specifications](#)  
Includes faceplate descriptions, jumper settings, motherboard and daughterboard drawings for the interface cards
- Chapter #8:** [RDC180-P Power Supply](#)  
Includes descriptions and technical specifications of the RDC180-P power supply, fuses, cables, cable connections, and jumper settings, along with the installation, replacement, and maintenance procedures for the unit
- Chapter #9:** [RDC180-HP Power Supply Revision B](#)  
Includes descriptions and technical specifications of the RDC180-HP power supply, fuses, cables, cable connections, and jumper settings, along with the installation, replacement, and maintenance procedures for the unit
- Chapter #10:** [AI325-AC Power Supply](#)  
Includes descriptions and technical specifications of the AI325-AC power supply fuses, cables, cable connections, and jumper settings, along with the installation, replacement, and maintenance procedures for the unit
- Chapter #11:** [RDC180-C Common Alarm Panel](#)  
Includes description and technical specifications of the RDC180-C Common Alarm Panel, fuses, cables, and cable connections, along with the installation, replacement, and maintenance procedures for the unit
- Chapter #12:** [RDC130-C Common Alarm Panel](#)  
Includes description and technical specifications of the RDC130-C Common Alarm Panel, along with the installation, replacement, and maintenance procedures for the unit
- Chapter #13:** [I710 Fuse Panel](#)  
Includes description and technical specifications of the Model I710 Fuse Panel, fuses, cables, and cable connections, along with installation, replacement, and maintenance procedures for the unit
- Chapter #14:** [AICOOL-48 Fan Unit](#)  
Includes description and technical specifications of the AICOOL-48 Fan Unit, fuses, cables, and cable connections, along with installation, replacement, and maintenance procedures for the unit

**Chapter #15:** [Distribution Panels](#)

Includes description and technical specifications of the different distribution panels used in a bay, cables, and cable connections, along with installation and replacement procedures for the panels

**Appendix A:** [Static Electricity \(ESD\)](#)

Includes information on what to do to eliminate equipment damage from static electricity, and description of a wrist strap

**Appendix B:** [Calculating Chassis Power Consumption](#)

Includes formulas for computing the amount of power used in a chassis

**Training  
Information**

Training is available for the AISwitch Series 180 and AISwitch Series 130. If you have Internet access, you can obtain more specific course information on the Applied Innovation Inc. (AI) Web site at:

<http://www.aiinet.com>

If you do not have Internet access, please contact the Training Manager at (800) 247-9482 for more specific course information.

## Contact Information

AI is dedicated to offering you timely, courteous technical support 24 hours a day, 7 days a week. AI's support personnel are highly trained and have the expertise to answer your questions.

Support is available between the hours of 8 a.m. and 6 p.m. (EST). During all other hours, support personnel are standing by to return your calls within two hours.

Before you call, please make sure you are at your computer and that you have the following information available so your problem can be resolved more quickly:

- The type of hardware you are using
- The error number and exact wording of any messages that appeared on your screen
- What happened and what you were doing when the problem occurred
- How you tried to solve the problem

To contact Technical Support, call (800) 246-7852 or email us at

[techsupp@aiinet.com](mailto:techsupp@aiinet.com)

These additional email contacts are also available:

National Sales Department	<a href="mailto:sales@aiinet.com">sales@aiinet.com</a>
Customer Service Department	<a href="mailto:cssupport@aiinet.com">cssupport@aiinet.com</a>
Marketing Department	<a href="mailto:info@aiinet.com">info@aiinet.com</a>
Human Resources Department	<a href="mailto:hr@aiinet.com">hr@aiinet.com</a>
Investment Relations	<a href="mailto:invest@aiinet.com">invest@aiinet.com</a>
Feedback for Engineering (R&D)	<a href="mailto:feedback@aiinet.com">feedback@aiinet.com</a>
About SNMP	<a href="mailto:snmp@aiinet.com">snmp@aiinet.com</a>
Webmaster	<a href="mailto:webmaster@aiinet.com">webmaster@aiinet.com</a>
Publications Department	<a href="mailto:aidoc@aiinet.com">aidoc@aiinet.com</a>

**Related  
Documentation**

Documentation for AI products includes the following:

<i>AI DOC CD-ROM</i>	AIDOC-002
<i>AI120 Contact Alarm Monitor User's Manual</i>	AI120UM
<i>AI192/AI196-X User's Manual</i>	192/196XUM
<i>AI193-ES User's Manual</i>	193ESUM
<i>AI193-FT User's Manual</i>	193FTUM
<i>AI193-TX User's Manual</i>	193TXUM
<i>AI194 User's Manual</i>	194UM
<i>AI196-ETS User's Manual</i>	E2AUM
<i>AI196-I User's Manual</i>	196IUM
<i>AI196-IEGB User's Manual</i>	196IEUM
<i>AI198 System Manager/User's Manual</i>	198UM
<i>AI2524 User's Manual</i>	2524UM
<i>AI2524/Cisco Documentation CD-ROM</i>	AIDOC-003
<i>AI294 User's Manual</i>	294UM
<i>AIM User's Manual</i>	AIMUM
<i>AIspy User's Manual</i>	SPYUM
<i>AI Switch Hardware Manual</i>	AIHM
<i>AppliedView User's Manual</i>	AVUM

To order these or any other AI manuals, please contact your sales representative at (800) 247-9482.

The most current version of release notes and user's manuals are also available on the AI Web Site at:

<http://www.aiinet.com>

To access AI documentation from the AI Web site, click [Documents].



## Document Registration

AI encourages you to register your documentation. Registration allows AI to continue to provide better documentation and services to you, our customers, and it allows us to inform you of upcoming documentation releases.

To register documentation, please fill out the registration form and/or contact AI at:

Applied Innovation Inc.  
Publications Dept.  
5800 Innovation Dr.  
Dublin, OH 43016-3271

Phone (614) 798-2000  
(800) 247-9482

FAX (614) 798-1770

Email [aidoc@aiinet.com](mailto:aidoc@aiinet.com)

If you have Internet access, you can also register your documentation online using the AI Web site at:



<http://www.aiinet.com>



**Text Conventions** Important concepts throughout this manual are emphasized with these special text styles:

**Table 1-1: Text Conventions**

Style	Definition
[Buttons]	Function buttons that appear on a screen are shown in regular body text and enclosed in square brackets. For example:  [Close]  [Send]
<b>Commands</b>	In command lines, type text that appears in this style exactly as shown:  <p style="text-align: center;"><b>avdumpdb</b></p> <p style="text-align: center;"><b>BNC OFF</b></p> Press the <Return> or <Enter> key after all commands.
<i>Variable Arguments</i>	Variable arguments are text that you specify. They are shown in italics. For example:  <p style="text-align: center;"><b>avaccess</b> <i>switch_name</i></p> In this case, “switch_name” is variable text. To enter the command, type  <p style="text-align: center;"><b>avaccess</b></p> and then the actual name of the switch.
...	Ellipses (...) signify that the preceding argument can be repeated a number of times. For example:  <p style="text-align: center;"><b>cat</b> <i>filename...</i></p> means that you would type <b>cat</b> followed by one or more filenames.

Style (Continued)	Definition
<p><b>[Optional Arguments]</b></p>	<p>Some arguments are optional. This means that you have the choice of including them or not. Optional arguments are shown enclosed in square brackets, which are not entered. For example:</p> <p style="padding-left: 40px;"><b>avrestore</b> [<i>directory</i>]</p> <p>means that you type:</p> <p style="padding-left: 40px;"><b>avrestore</b></p> <p>and (if you need to include a directory) type the actual path name.</p> <p style="padding-left: 40px;"><b>CFGMSG</b> <i>n</i>, [<b>DEFAULT</b>]</p> <p>means that you type <b>CFGMSG</b> followed by a message number, a comma, and (optionally) the word <b>DEFAULT</b> without brackets.</p>
<p>{<i>argument</i>   <i>argument</i>}</p>	<p>Arguments between braces are grouped into one unit. The vertical bar signifies that either the first or second argument can be used. The braces and vertical bar are not entered. For example:</p> <p style="padding-left: 40px;"><b>ls</b> {<i>file</i>   <i>directory</i>}</p> <p>means that you would type <b>ls</b> followed by either a file or a directory name.</p>
<p>&lt;Keys&gt;</p>	<p>Keyboard controls are shown in this style. Angle brackets depict keys that do not appear on the screen when pressed, such as the &lt;Tab&gt; or &lt;Enter&gt; keys. Keys used in combination are connected with a dash. For example, to enter:</p> <p style="padding-left: 40px;">&lt;Alt-SysRq&gt;</p> <p>hold down the &lt;Alt&gt; key while you press the &lt;SysRq&gt; key.</p>

Style (Continued)	Definition
Labels	<p>Labels are used in diagrams and within the main text to designate physical components such as jumper straps, switches, and cable connectors. For example:</p> <p>On/Off Switch</p> <p>Ethernet Port</p> <p>Place the On/Off switch in the off position.</p>
Menu   Submenu	<p>Pull-down menu selections are shown in bold text. The bar separates the main menu from submenus. For example:</p> <p><b>File   Exit</b></p> <p>indicates that you should click <b>File</b> and then click <b>Exit</b>.</p>
Screen output	<p>Screen shots, system prompts, and error messages displayed on the screen are shown in this style:</p> <pre>+CONFIG PORT, LPORT=40, HPORT=47, BITS=8 +CONFIG PORT, LPORT=48, HPORT=49, BITS=7 +CONFIG PORT, LPORT=50, BITS=8\$0778</pre>
<b>Note:</b>	<p>Note messages indicate neutral or positive information that emphasizes or supplements important points of the main text. For example:</p> <p><b>Note:</b> Parameters and their specific values are discussed as they are entered into the configuration file.</p>
 <p><b>Caution:</b></p>	<p>Caution messages indicate that failure to take a specified action could result in loss of data and/or harm to the software or hardware. For example:</p>  <p><b>Caution:</b> Personnel handling circuit cards must wear an antistatic wrist strap and follow electrostatic procedures at all times.</p>

Style (Continued)	Definition
 <b>Warning:</b>	<p>Warning messages indicate that failure to take a specified action could result in physical harm to the user. For example:</p>  <b>Warning:</b> To reduce the risk of electrical shock, turn off the input power to the power supply before servicing.
<p>File Edits</p>	<p>Lines of code from a configuration or other file that the user will edit are sometimes shown within procedures. Variables appear in italics. For example:</p> <pre>BEGIN DSP <i>name</i></pre>



# Chapter 2: Site Requirements

## AI180 Clearance Requirements

The AISwitch Series 180 chassis mounts in either a 19-inch (48.26 cm) or 23-inch (58.42 cm) rack mounting unit. Use the rack mounting ears to install the chassis in the bay. [Figure 2-1](#) shows the minimum clearance requirements of the AI180.

**Figure 2-1: Minimum Clearance Requirements**

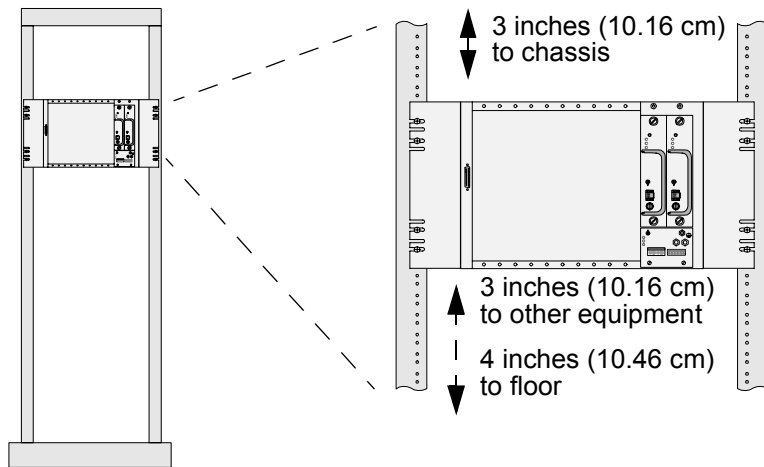

**Table 2-1: AI180 Chassis Specifications**

Specification	Description
Height	12.05 in. (30.6 cm)
Width	16.85 in. (42.8 cm)
Depth	9.99 in. (25.37 cm)
Weight - with components installed	Approximately 35 lbs. (16 kg)

**AI180  
Environmental  
Requirements****Table 2-2: Ambient Environmental Requirements for the AI180**

<b>Specification</b>	<b>Description</b>
Maximum Operating Temperature	50 ° C
Power Requirements	Standard -48 VDC Central Office power -200 to 300 W
Operating Environment	5 ° C to 40 ° C 5 to 85% relative humidity, non- condensing



### AI130 Clearance Requirements

The AISwitch Series 130 chassis mounts in 23-inch (58.42 cm) rack mounting unit. Use the rack mounting ears to install the chassis in the bay. [Figure 2-2](#) shows the minimum clearance requirements of the AI130.

**Figure 2-2: Minimum Clearance Requirements**

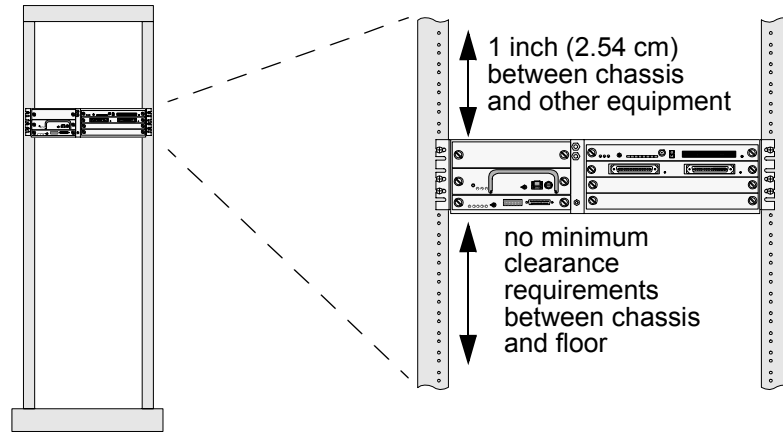

**Table 2-3: AI130 Chassis Specifications**

Specification	Description
Height	5.22 in.(13.26 cm)
Width	21 in. (53.34 cm)
Depth	9.76 in. (24.79 cm)
Weight	Approximately 25 lbs. (11.34 kg) which includes dual DC power supplies, three cards, and a common logic controller.

### AI130 Environmental Requirements

**Table 2-4: Ambient Environmental Requirements for the AI130**

Specification	Description
Maximum Operating Temperature	50 ° C
Power Requirements	Standard -48 VDC Central Office power -200 to 300 W
Operating Environment	5 ° C to 40 ° C 5 to 85% relative humidity, non-condensing



# Chapter 3: AI180 Hardware Overview

## Overview

The AISwitch Series 180 allows incompatible telecommunication network elements to communicate over a variety of Wide Area Networks (WAN) while acting as a network mediation device.

This component describes the AISwitch Series 180 chassis, the installation of various components in the chassis, and the installation of additional hardware equipment located in the bay in the telecommunications facility.

**Figure 3-1: Typical AISwitch Network Installation**

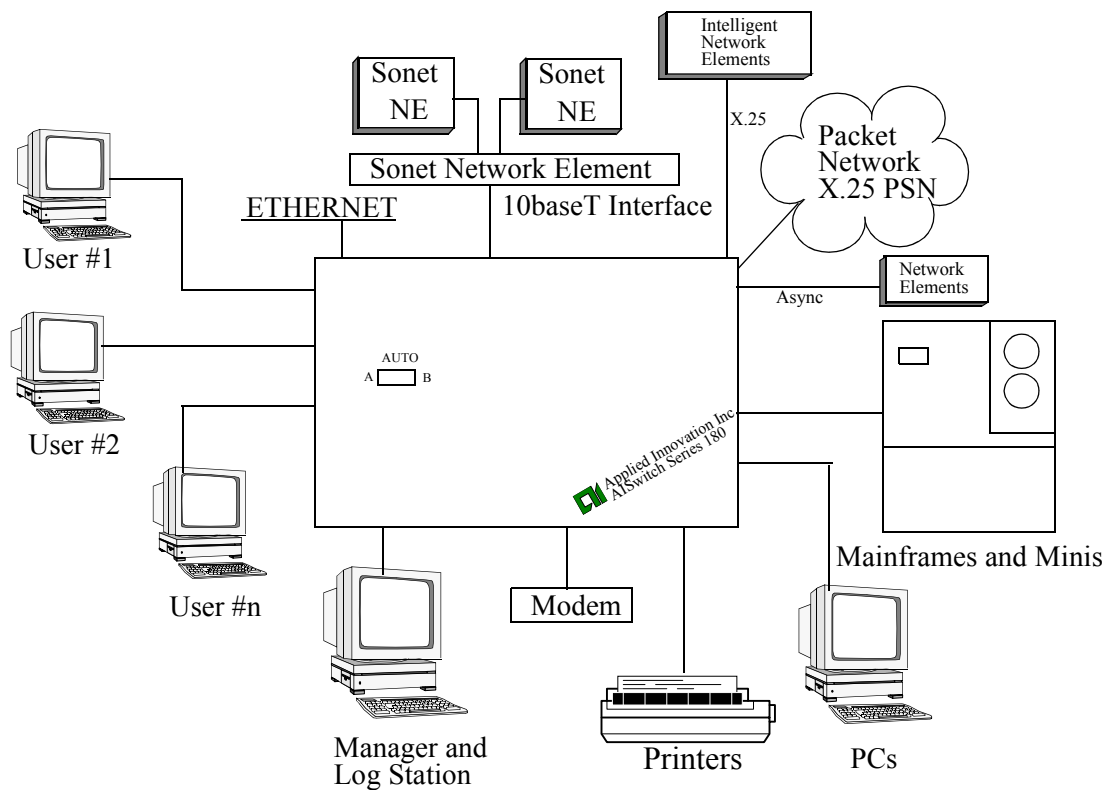

## **AISwitch Interconnectivity**

The AISwitch provides interconnectivity between network elements or nodes and Wide Area Networks (WANs). The AISwitch Series 180 is a network mediator. A single chassis provides

- Network Element Physical Connectivity

The AISwitch Series 180 provides networking and interconnectivity through various protocols including: Asynchronous, X.25, TCP/IP, E2A, OSI, and TBOS.

- Wide Area Network Connectivity

The AISwitch Series 180 provides networking and interconnectivity both locally and remotely through the following types of WAN: X.25, IP, and OSI.

- Operation Support System Connectivity

The AISwitch Series 180 provides Operational Support System (OSS) connectivity to various OSS interfaces including: E2A, TBOS, Asynchronous, X.25, TCP/IP, or OSI.

Two AISwitch 180 chassis can be connected to form an expanded system. Applied Innovation Inc. recommends that an expanded system contains a maximum of two chassis. The first of these chassis is referred to as the primary chassis. The second chassis, called the expander or expansion chassis, includes a specialized AI182 expander card in place of the common logic card. Refer to the [AISwitch Series 180 Chassis Assembly](#) component for more details.

## **AISwitch Series 180 Chassis Components**

Standard components installed in the AISwitch Series 180 Chassis include:

- [AISwitch Series 180 Chassis](#)
- [AI180 Backplane](#)
- [Craft Port Connection](#)
- [RDC180-C Common Alarm Panel](#)
- [Mounting Ears](#)
- [Heat Deflection Baffle](#)

Optional components installed in the AISwitch Series 180 Chassis include:

- [AI198 Common Logic Card](#)
- [AI182 Expander Card](#)
- [AI183 and AI185 Asynchronous Line Cards](#)
- [AI192 and AI196-X X.25 Interface Cards](#)
- [AI196-ETS Gateway Interface Card](#)
- [AI196-I Gateway Interface Cards](#)
- [AI193-TX Ethernet Gateway Card](#)
- [AI193-ES Ethernet OSI Interface End System](#)
- [AI194 Ethernet Hub Card](#)
- [AI294 Ethernet Switch](#)
- [AI2524 Multi-Protocol Router Card](#)
- [Power Supplies](#)
- [I710 Fuse Panel](#)
- [AICOOL-48 Fan Unit](#)
- [Distribution Panels](#)

### AISwitch Series 180 Chassis

The AISwitch Series 180 chassis contains twelve slots. The slots are not physically numbered but referenced from left to right facing the cabled side of the chassis. The first two slots on the left are slots A and B; the next slots are slots 1 through 8 as the diagram illustrates. The last two slots on the far right house the power supplies.

**Figure 3-2: AISwitch Series 180 Chassis Slot Locations**

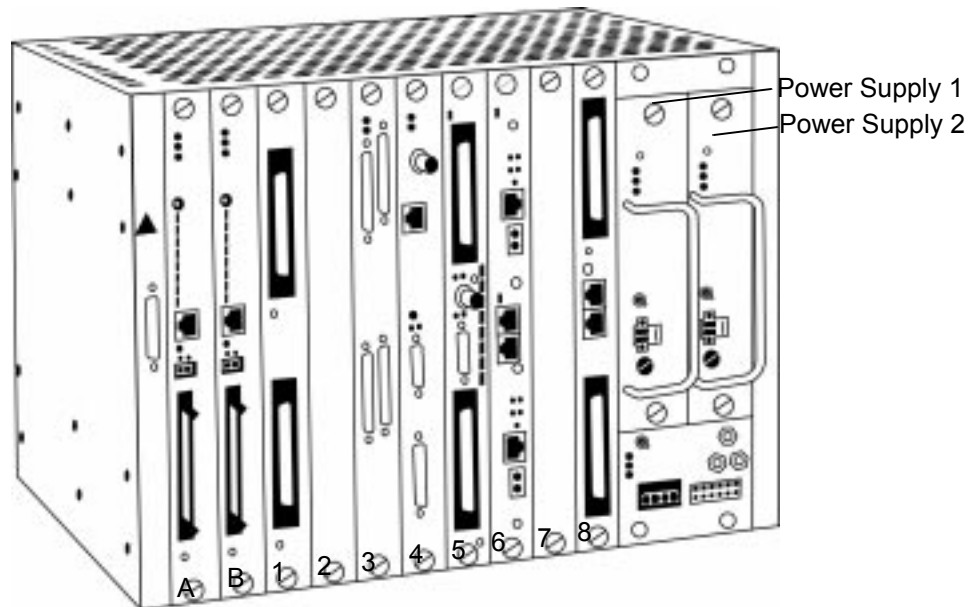

The craft port connection plate is located on the cabled side at the far left of the enclosure. Refer to the [AISwitch Series 180 Chassis Assembly](#) component for more details regarding the cabling of this connector.

In the primary chassis, the first two slots, A and B, remain reserved for the primary and optionally redundant common logic cards. The expansion chassis contains the expander cards in slot A and B in place of common logic cards. Only one expansion chassis per system is recommended.



**Caution:** Do not put any card except the AI198 CLC or the AI182 expander card into slot A or B of any chassis. Damage to the network card will result.

Slots 1 through 8 in the chassis are reserved for a maximum of eight network cards in either the main chassis or the expansion chassis. The AC power supply or one or two DC power supplies are located on the far right of the chassis. The RDC180-C Common Alarm Panel is located beneath the power supplies.

Figure 3-3: Typical AISwitch Series 180 Chassis

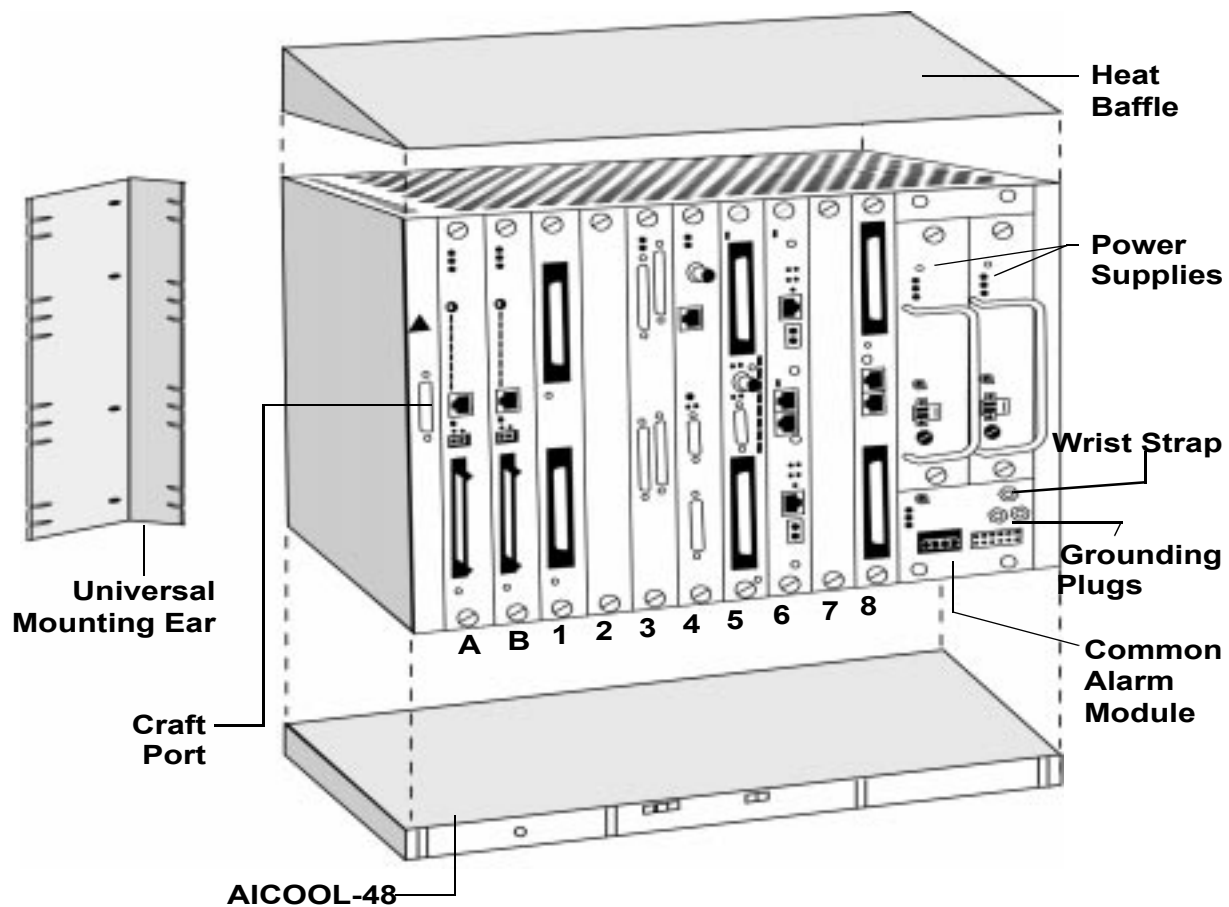

If there is not a card installed in one of the slots, it is recommended that you install a blank cover plate. Refer to the [AISwitch Series 180 Chassis Assembly](#) component for step-by-step installation or replacement instructions of the components. For more details regarding the chassis components, refer to these components:

- [AISwitch Series 180 Chassis Assembly](#)
- [RDC180-P Power Supply](#)
- [RDC180-HP Power Supply Revision B](#)
- [AI325-AC Power Supply](#)
- [RDC180-C Common Alarm Panel](#)
- [AICOOL-48 Fan Unit](#)

## AI180 Backplane

The AI180 backplane provides connectivity and distributes power to the installed network interface cards, common logic controllers, and the RDC180-C Common Alarm Panel. The backplane distributes the +5 volts, +12 volts, and -12 volts from the installed power supplies. It also provides the craft port connection.

The backplane is bolted to the inside of the non-cabled faceplate of the chassis. All the cards mount into the backplane connector when properly installed. Refer to the [AISwitch Series 180 Chassis Assembly](#) component for more details.

## Craft Port Connection

The DB25 female craft port connector lies on the left side of the cabled face of the chassis. This port is an asynchronous serial RS232 DTE port which allows:

- Access to the active CLC
- Access to the CLC menus to configure the switch from any remote terminal
- Execution of winslc commands
- Execution of CLC shell commands



### RDC180-C Common Alarm Panel

The common alarm panel provides an external alarm interface for the AI180. It also provides additional cooling to the power supplies. The common alarm panel is located beneath the AC power supply or the DC power supplies on the cabled side of the AI180 chassis.

While single fan units are currently in use in some customer sites, the two fan unit is the current RDC180-C. The RDC180-C must be upgraded to a two-fan unit if using the RDC180-HP Power Supply. See the [Calculating Chassis Power Consumption](#) component for determining which power supply to use.

The two fan unit has a double-holed lug connection as illustrated.

**Figure 3-4: RDC180-C Common Alarm Panel - Two Fan Unit**

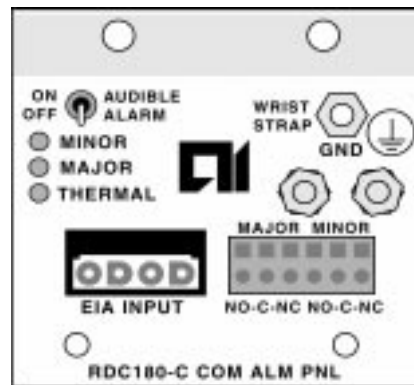

Refer to the [RDC180-C Common Alarm Panel](#) component for more details.

### Mounting Ears

The AISwitch Series 180 chassis enclosure uses one universal mounting ear set. One mounting ear on each side of the chassis allows the chassis to be mounted to either a 19-inch or a 23-inch mounting bay.

To mount a chassis in a 19-inch (48.26 cm) bay, the larger section of the universal mounting ear is flat against the chassis. The smaller section is flat against the mounting bay with the slots in the mounting ears aligned with the holes in the bay where the chassis is to be placed.

To mount a chassis in a 23-inch (58.42 cm) bay, the smaller section of the universal mounting ear is flat against the chassis. The larger section is flat against the mounting bay with the slots in the mounting ears aligned with the holes in the bay where the chassis is to be placed. The mounting ears and heat deflector are standard components on the chassis.

Refer to the [AISwitch Series 180 Chassis Assembly](#) component for more details regarding installation or replacement of these ears.

## Heat Deflection Baffle

The heat deflection baffle is installed at the top of the AI180. It deflects the heat generated within the chassis away from equipment mounted above the chassis. The following illustrates an installed heat baffle.

**Figure 3-5: Heat Deflection Baffle**

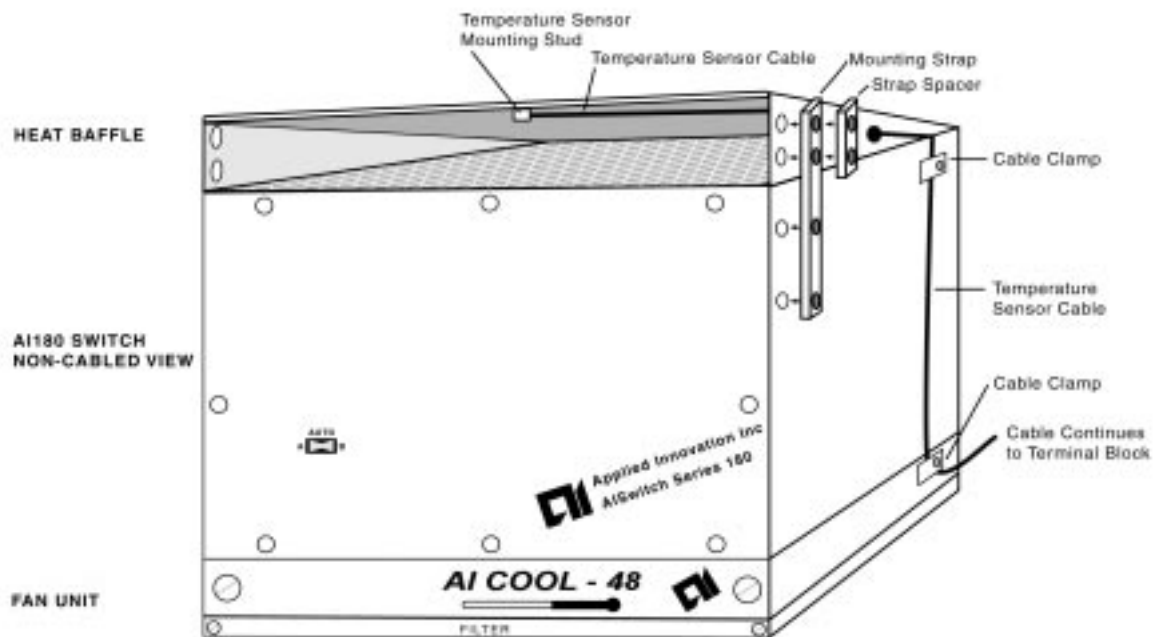

Refer to the [AISwitch Series 180 Chassis Assembly](#) and the [AICOOL-48 Fan Unit](#) component for more details regarding installation or replacement of this heat deflection baffle.

## AI198 Common Logic Card

The AI198 Common Logic Card (CLC) is installed in slots A and/or B of the primary chassis. The backplane into which this CLC connects must be a revision 9 or higher. Facing the cabled side of the chassis, slots A and B are the first two slots on the left side of the chassis.



**Caution:** Do not put any card except the AI198 CLC or the AI182 expander card into slot A or B of any chassis. Damage to the network card and backplane will result.

The AI198 allows redundant controller functionality. If the primary controller in slot A fails, the optional redundant backup controller in slot B automatically assumes control of the switch if the CLC selector switch on the chassis is set to the AUTO position.

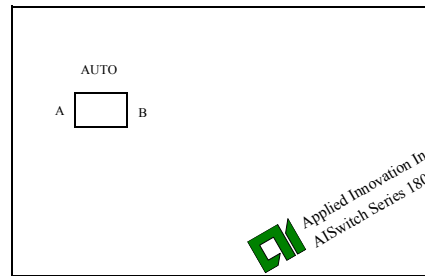
**Figure 3-6: AI198 Common Logic Card Selector Switch**

The AI198 provides SNMP, telnet, FTP, and software download capabilities.

There must always be a AI198 in either slot A or B of the primary chassis, and an AI182 expander card in slot A or B of the expansion chassis. Refer to the *AI198 System Manager/User's Manual* for more details regarding the configuration of the AI198.

### AI182 Expander Card

The expansion chassis utilizes the AI182 expander card. Inserted into slot A or B in the expansion chassis, this card acts as a TDS-bus repeater from the primary chassis backplane to the expansion chassis backplane in the bay. If redundant operation is needed, insert an AI182 in each A and B slot in the expansion chassis.



**Caution:** Do not put any card except the AI198 or the AI182 expander card into slot A or B of any chassis. Damage to the network card will result.

The AI182 includes an expansion cable, RIBCB1 that is used to connect the AI182 to the BUS OUT connector on the front of the AI198 of the primary chassis.

Refer to the [Interface Card Hardware Specifications](#) component for more information regarding the faceplate.

### AI183 and AI185 Asynchronous Line Cards

Slots 1 through 8 of the AI180 chassis hold various types of line cards. The AI183 and AI185 are the asynchronous line cards available for the AI180 chassis.

The AI183 is a 4-port product designed for asynchronous terminal server applications. The AI183 is a 4-port (RS232) asynchronous DTE interface module with integral voltage surge protection and standard DB25 pin termination.

The AI185 is a 16-port (RS232) asynchronous DTE interface module with dual Telco standard 25 pair (50-pin) termination. The AI185 requires the use of a distribution panel including either the DP185-19/23, DP185B-19/23, or DP185RJ45-19/23. Refer to the [Interface Card Hardware Specifications](#) component and the [Distribution Panels](#) component for more details.

The asynchronous line cards are SNMP manageable.

### AI192 and AI196-X X.25 Interface Cards

The AI192 and AI196-X interface cards are available in several different variations.

The AI192 provides X.25 access to Wide Area Networks (WANs) and Operational Support Systems (OSSs) and provides 4-ports (RS232, RS530, and V.35 physical connectivity).

The daughterboard supports specific types of connectors for the AI192 as shown in [Table 3-1](#).

**Table 3-1: AI192 Interface Card Connectors**

Card Model	Daughterboard	Type of Connector Supported
AI192-XR4	AI004	RS232
AI192-XE4	AI009	EIA RS530
AI192-XV1	AI005	V.35
AI192-XT2	AI010-2T	T1

The AI192 provides up to 256 virtual circuits with any combination of PVCs or SVCs, PVC to SVC conversion, SNMP manageability, and software download capability. Refer to the *AI192 User's Manual* for more details.

The AI196-X provides 16-port X.25 access to WANs and Operational Support Systems. It requires a distribution panel and interconnecting cables.

A required daughterboard supports specific types of connectors for the AI196-X card for specific links as shown in [Table 3-2](#).

**Table 3-2: AI196-X Interface Card Connectors**

Links	Daughterboard	Type of Connector Supported
1 - 4, 5 - 8	AI016-I	RS232
9 - 12, 13 - 16	AI016-C	RS232

Links	Daughterboard	Type of Connector Supported
1 - 4, 5 - 8	AI017-I	RS530
9 - 12, 13 - 16	AI017-C	RS530
1 - 4, 5 - 8	AI032-I	V.35
9 - 12, 13 - 16	AI032-C	V.35

The AI196-X provides up to 512 virtual circuits (also called logical channel numbers) with any combination of PVCs or SVCs, SNMP manageability, and software download capability. Refer to the *AI196-X User's Manual* for more details.

### AI196-ETS Gateway Interface Card

The AI196-ETS facilitates the transmission of the following over an IP network:

- E2A data from E2A Remote Terminal Units (RTUs) to the Network Monitoring and Analysis (NMA) computer
- E2A requests from the NMA computer to E2A RTUs

The AI196-ETS replaces the direct connections between 202T modems (one at the NMA end, one at the RTU end) with a router network and a WAN. It supports the following RTUs: DAS, APR, ATP, SAC, GTP, and RTUs manufactured by Harris and Dantel. Also it can also connect to 202T modems.

The AI196-ETS supports E2A and asynchronous protocols. Each card provides up to 16 E2A links and each link supports up to 16 E2A RTU addresses. Each RTU supports up to 60 displays per RTU address. An AI196-ETS card connected to an NMA supports 15360 displays.

### AI196-I Gateway Interface Cards

The AI196-I series provides 16 ports of either X.25 or asynchronous data over preconfigured RS232, RS530, or V.35 interfaces. Protocol changes to a single port are made without interrupting communications on other ports of the module and the AISwitch.

For X.25 operation, the card provides up to 1024 virtual circuits with a maximum of 512 PVCs supported. The AI196-I provides PVC to SVC conversion, software download capability, SNMP monitoring, and IP tunnels over X.25 networks.

The AI196-IEGB provides TBOS to TL1 conversion with RS-530/422 interface. Refer to the *AI196-I User's Manual* and the *AI196-IEGB User's Manual* for more details.

### **AI193-TX Ethernet Gateway Card**

The AI193-TX is a gateway card to Ethernet TCP/IP networks. Asynchronous or X.25 NEs connect through the AISwitch to the AI193-TX and then to a TCP/IP based network. The AI193-TX supports 512 logical channels over a muxed connection. Physical interfaces to this card include a 10BaseT, AUI, and COAX connection.

The AI193-TX includes:

- Connectivity requirements from the Class 5 central office switches to TCP/IP based network elements
- An asynchronous RS-232 port to provide diagnostic and performance information

The AI193-TX card is SNMP manageable and provides software download capability.

Refer to the *AI193-TX User's Manual* for more details.

### **AI193-ES Ethernet OSI Interface End System**

The AI193-ES is an Ethernet interface card which terminates the OSI stack from an NE, takes the message set on the application layer, and places it in either an X.25 or TCP/IP protocol data unit. This card allows conversion from an OSI 7-layer stack running a TL1 application to a 3-layer X.25 stack running a TL1 application.

The AI193-ES card is SNMP manageable, provides software download capability, and allows for TARP arbitration.

Refer to the *AI193-ES User's Manual* for more details.

### **AI194 Ethernet Hub Card**

The AI194 is a 24-port Ethernet connection hub designed to build central office-based LANs. The card contains one thin COAX 10Base2 connection, one AUI connection, and two 25 pair Telco connectors. The Telco connectors provide 24 10BaseT ports when connected to a DP194 distribution panel.

The AI194 is SNMP manageable and provides software download capability.

Refer to the *AI194 User's Manual* for more details.

### AI294 Ethernet Switch

The AI294 is an Ethernet switch, which provides three different physical interfaces, and isolates certain types of NEs to increase the efficiency of central office-based LANs.

**Table 3-3: Available AI294 Models**

<b>Model Number</b>	<b>Connector Ports</b>
AI294-2	Nine 10Base2
AI294-T	Nine 10BaseT
AI294-T/FL	Seven 10BaseT Two 10BaseFL (fiber)

The AI294 provides flow control, store and forward switching, self-learning address tables, user-defined filtering on any port or address, and local and remote switch access.

The AI294 also has an internal IRB ethernet port which allows other ethernet line cards in the switch to connect to the AI294.

The AI294 is SNMP manageable and provides software download capability.

Refer to the *AI294 User's Manual* for more details.

### AI2524 Multi-Protocol Router Card

The AI2524 is a multi-protocol router card which includes the Cisco IOS™ Router technology. The basic AI2524 includes one Ethernet LAN interface with an internal IRB ethernet backplane port and a 10BaseT port on the faceplate panel.

The AI2524 protocols supported are TCP/IP, OSI, X.25, and protocol encapsulation (X.25 through TCP/IP, OSI through TCP/IP, and OSI through X.25).

The base unit accepts two serial interface modules in the following available configurations:

**Table 3-4: AI2524 Module Configurations Available**

<b>Router Model</b>	<b>Serial Interface Configuration</b>
AI2524-TT	Two integrated CSU/DSU connections which each support full or fractional T1-leased line services
AI2524--55	Two synchronous serial lines; cables allow selection of RS-232, EIA-530 DCE, RS-449, or V.35 interfaces
AI2524-44	Two integrated CSU/DSU connections which support 4-wire 56k/64k leased line or switched services
AI2524-T5	One integrated T1 CSU/DSU cable interface and one 5-in-1 synchronous serial cable interface; cables allow selection of RS-232, EIA-530 DCE, RS-449, or V.35 interfaces.
AI2524-T4	One integrated T1 CSU/DSU cable interface and one integrated 4-wire 56k/64k CSU/DSU; this supports a T1 WAN interface plus a dial-up switched 56k backup connection

The AI2524 is SNMP manageable and provides software download capability.

Refer to the *AI2524 User's Manual* for more details.



## Power Supplies

Three power supplies are currently available for the AI180 chassis. The power supplies provide power to the AI180 backplane. See the [Calculating Chassis Power Consumption](#) component to determine the necessary power supply for your chassis.

The DC power supplies available include the RDC180-P and the RDC180-HP Revision B. The AC power supply available is the AI325-AC.

**Note:** Applied Innovation recommends using the RDC180-HP Power Supply.

### RDC180-P Power Supply

The RDC180-P is used in an AI180 chassis where the +5 volts DC power consumption is less than 14.9 amps. Each RDC180-P occupies a single power supply slot. Two RDC180-P DC power supplies are used in a chassis to provide redundant power if one of the units should fail in service. See the [Calculating Chassis Power Consumption](#) appendix for the formulas used to compute the power used by the components of a chassis.

Designed to operate with a DC input voltage between -39 volts DC and -63 volts DC, the RDC 180-P should utilize a nominal input voltage of -48 volts DC. This power supply converts the incoming -48 volts DC power to the +5 volts, +12 volts, and -12 volts DC needed for the individual network interface cards installed in the chassis. See [Figure 3-3](#) for location of the power supplies.

Refer to the [RDC180-P Power Supply](#) component for more details regarding the RDC180-P technical specifications, installation, and replacement.

**Figure 3-7:**  
**RDC180-P Faceplate**

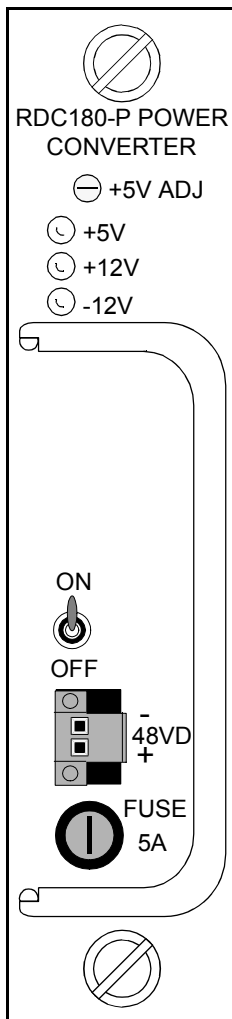

### RDC180-HP Revision B Power Supply

**Figure 3-8: RDC180-HP Revision B Power Supply**

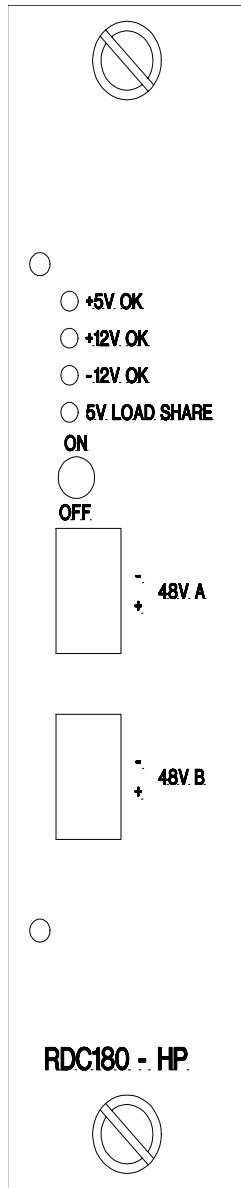

The RDC180-HP is used in an AI180 chassis where the +5 volts DC power consumption is greater than 14.9 amps. See the [Calculating Chassis Power Consumption](#) component for the formulas used to compute the power used by the components of a chassis.

Each RDC180-HP occupies a single power supply slot. Two RDC180-HP DC power supplies are used in a chassis to provide redundant power if one of the units should fail in service.

Applied Innovation recommends using the RDC180-HP Revision B for all applications. Refer to the [RDC180-HP Power Supply Revision B](#) component.

### AI325-AC Power Supply

The AI325-AC power supply is positioned in the chassis above the RDC180-C Common Alarm Panel. The AI325-AC occupies two power supply slots. This power supply converts the incoming 120V AC power to the +5 volts, -12 volts, and +12 volts DC needed by the chassis components.

**Figure 3-9: AI325-AC Power Supply Faceplate**

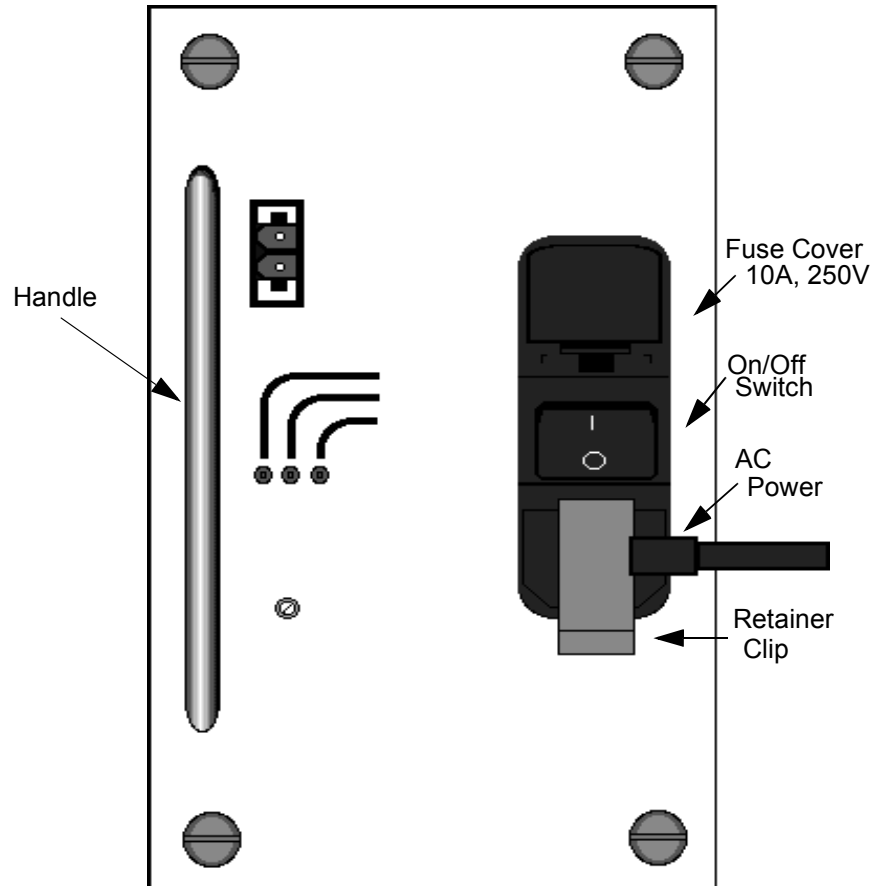

Refer to the [AI325-AC Power Supply](#) component for more details regarding the AI325-AC technical specifications, installation, and replacement.

### I710 Fuse Panel

The I710 fuse panel provides redundant current protection for 20 circuits using GMT type fuses. The panel operates at -48V DC and distributes up to 60 amps of total current from two separate 30 amp fuses (A and B).

The unit provides an indication of fuse failure, major bay alarms, and minor bay alarms for that specific bay or for other sources through major and minor bay alarm circuits.

For a complete list of the fuses and cable connections for this component, refer to the [I710 Fuse Panel](#) component for more details.

The noncabled faceplate of the I710 Fuse Panel is shown below.

**Figure 3-10: I710 Fuse Panel - Non-Cabled Side**



The cabled side of the I710 Fuse Panel is shown below.

**Figure 3-11: I710 Fuse Panel - Cabled Side**

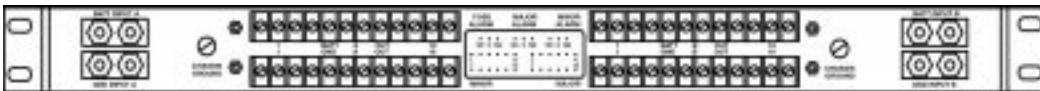

For a complete description of the faceplate and the cabled side of the fuse panel and step-by-step installation or replacement instructions, refer to the [I710 Fuse Panel](#) component.

### AICOOL-48 Fan Unit

The AICOOL-48 provides forced air circulation for better cooling. The purpose is to keep the components of the AI180 chassis cool by forcing room temperature air into the chassis from underneath and to provide an alarm output in the event of a unit or major component failure.

The AICOOL-48 Fan Unit is a self-contained cooling units which mounts to the bottom of the AISwitch Series 180 hardware chassis. Both units provide slide-out access to its components from the noncabled side of the unit.

If you have more than four AI196-I cards or an AI294 card in your AISwitch Series 180 hardware chassis, the AICOOL-48 is a requirement.

#### Figure 3-12: AICOOL-48 Fan Unit - Cabled Side

Handle

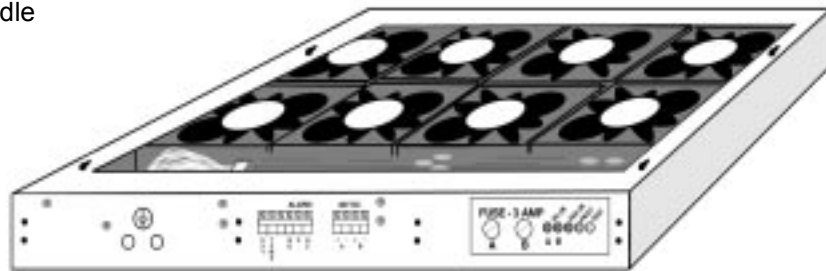

#### Figure 3-13: AICOOL-48 Fan Unit - Noncabled Side

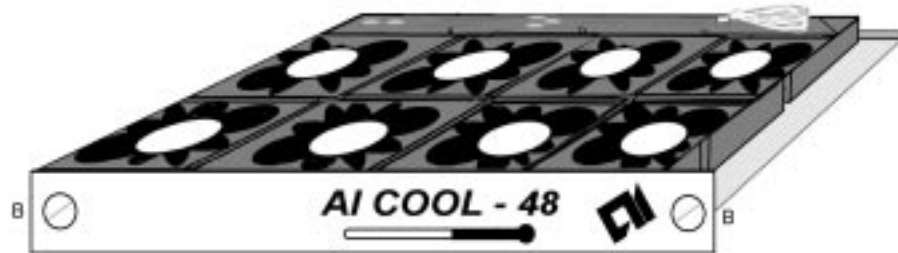

The cooling fan unit attaches to the bottom of the chassis. Refer to the [AICOOL-48 Fan Unit](#) component for more details about this hardware bay component.

## Distribution Panels

Several Applied Innovation Inc. distribution panels are available. The distribution panels provide patching, distribution, consolidation, and termination for many of the cable types used in Central Offices, operations centers, and other telecommunication facilities. The type of distribution panel used relates to a specific card.

Some panels are available for either 19-inch mounting bays or 23-inch mounting bays. These panels provide cable management and convenient cable and connector access.

The distribution panels are generally placed above the AISwitch 180 chassis, depending on which cards are loaded into the chassis. Refer to the [Distribution Panels](#) component for more details.

**Table 3-5: Distribution Panels**

Distribution Panel	Size Available	Associated Card
DP120	19-inch 23-inch	AI120 (nonpowered inputs only)
DP185	19-inch 23-inch	AI185
DP185B	19-inch 23-inch	AI185 Revision 5
DP185RJ45	19-inch 23-inch	AI185
DP194	19-inch 23-inch	AI194
DP196	19-inch 23-inch	AI196-I; AI196-IEGB; AI196-X
DP196-A	23-inch	AI196-I; AI196-IEGB; AI196-X
I709	23-inch	Generic
I711	23-inch	Generic

**Other Vendor  
Components**

The mounting rack, or network bay, can be assembled at the factory from customer-supplied specifications. Components from other vendors can be integrated into the bay along with The AISwitch Series 180 equipment. Refer to the documentation for the vendor-supplied units for the operation and maintenance of their components.

**Network  
Equipment  
Building  
Standards**

Equipment used in the telecommunications facility generally must meet Network Equipment Building System (NEBS) standards which dictate specific requirements regarding space utilization and operation within a central office environment. The AISwitch Series 180 meet NEBS requirements.

For a complete explanation of the requirements, refer to the Bellcore NEBS Requirements: Physical Protection. The document number is GR-63-CORE (a module of LSSGR, GR-64; TSGR, FR-440, and NEBS FR, FR-2063).





# Chapter 4: AISwitch Series 180 Chassis Assembly

## Overview

This component lists how to install or replace the AISwitch Series 180 chassis, mounting ears, heat deflection baffle, AI198, and interface cards along with component location and technical specifications.

For configuration details on each of the chassis cards supported, refer to the User's Manual for the specific card and the *AI198 System Manager/User's Manual*.

## Electrostatic Warning

The AISwitch contains electrostatic sensitive components. Proper handling, shipping, and storage precautions must be exercised.

- Removal and installation of circuit boards must be performed in a static-free environment. A technician should wear an anti-static wrist strip and stand on an anti-static mat. Both the wrist strap and mat must be grounded at the same point as the AISwitch enclosure.
- When not in use, circuit boards must be kept in their anti-static plastic bags.
- Circuit boards must only be removed from their anti-static plastic bags immediately prior to installation into the AISwitch enclosure.
- Immediately upon removal from the enclosure, circuit boards must be inserted into their anti-static bags.
- Do not ship or store the electronic circuit boards near strong electrostatic, electromagnetic, magnetic, or radioactive fields.

## Unpacking

Unpack the enclosures and cards placing them on a static-free work area. Inside the packaging you will find the rack mounting brackets (AI Part 06-170-012) and the power cord (if your system operates on AC power). To install or adjust the settings for the cards in your system, remove the blank cover plates from the cabled side of the unit if necessary.

Figure 4-1: AISwitch Series 180 chassis

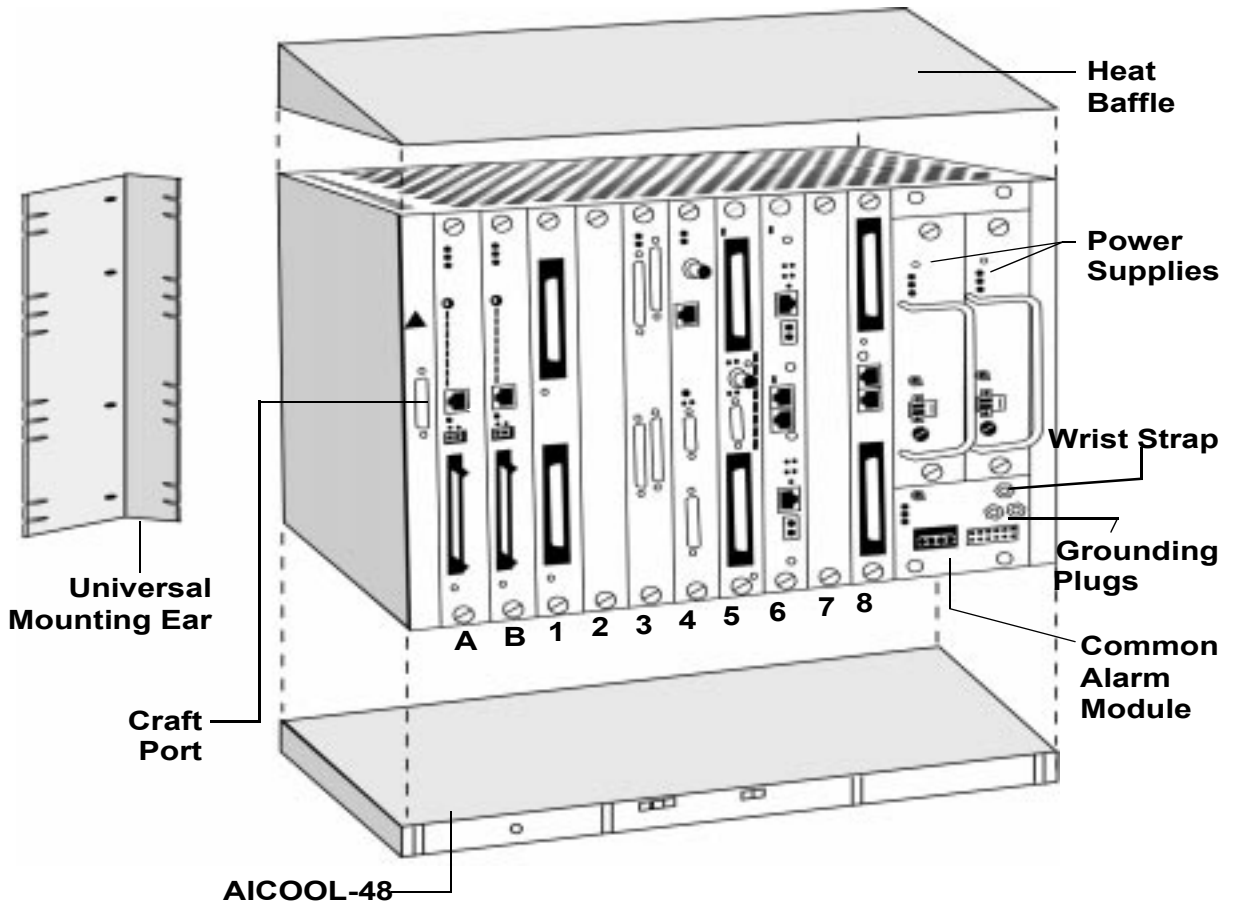

**Table 4-1: AI180 Chassis Technical Specifications**

Specification	Description
Network Cards	Use one to eight AI network interface cards.
Dimensions	Height: 12.05 in. (30.6 cm) Width: 16.85 in. (42.8 cm) Depth: 9.99 in. (25.37 cm)
Weight - with components installed	Approximately 35 lbs. (16 kg)
Material	20-gauge steel with mounting holes for front center or rear rack mounting
Power Supplies	<p>The AISwitch 180 operates on one of three power supply options:</p> <ul style="list-style-type: none"> <li>● RDC180-HP. A -48 VDC power supply which also operates in the AI180 with single or redundant configurations.</li> <li>● RDC180-P. A -48 VDC power supply which will also operate in the larger AI180 in Telco applications with single or redundant configurations.</li> <li>● AI325-AC. A non-redundant power supply for 102 to 264 VAC, 47 to 63 Hz, and 325 W.</li> </ul> <p>Refer to the <a href="#">Calculating Chassis Power Consumption</a> to determine the correct power supply for the chassis.</p>
Mounting Data	Mounting ears (AI Part 06-170-012) available to mount the chassis to a 19 in. (48.26 cm) or 23 in. (58.42 cm) rack

## Installing the AISwitch Series 180 Chassis



**Caution:** Before beginning the installation of any AI component, the operator and equipment must be grounded by the mechanism used at the installation site. Refer to the [Static Electricity \(ESD\) Appendix](#) for more details about the grounding process.

These instructions refer to a typical chassis which includes pre-installed chassis cards, power supplies and the common alarm panel. Use this procedure to install the mounting ears in the desired position, mount the chassis in the bay, install the heat deflection baffle on the chassis (if not already installed), and properly ground the chassis.

1. Install the mounting ears (AI Part 06-170-012) on the chassis in the proper position as shown in [Figure 4-2](#) using the Phillips flat head machine screws provided (AI Part 00-010-002).

**Note:** If the chassis is installed in the bay at Applied Innovation as part of a System Integration package, the mounting ears are attached to the chassis.

- If mounting in a 19-inch bay, install the mounting ears so the wider section of the ear is attached to the side of the chassis shell.
  - If mounting in a 23-inch bay, install the mounting ears so the narrowest section of the ear is attached to the side of the chassis shell. The mounting ears are attached to the holes in the side of the chassis. The hole alignment allows for front, middle, or rear mounting.
2. Place the chassis in the bay installation location after attachment of the mounting ears. Refer to the local specifications of the telecommunications facility for the proper position. See the [Site Requirements](#) component.

**Note:** If the chassis is mounted too close to the floor, proper upward air flow may be adversely affected. Allow four inches between the floor and the bottom of the chassis to ensure proper air flow.

Two people are recommended at this point. One holds the chassis with the attached mounting ears in position while the other fastens the ears to the bay flange with the philips pan head machine screws provided.

3. Leave about three inches of vertical space above the chassis to accommodate the heat deflection baffle. Refer to the section on [AICOOL-48 Fan Unit](#).

Figure 4-2: Installation of the Mounting Ears and Heat Deflector

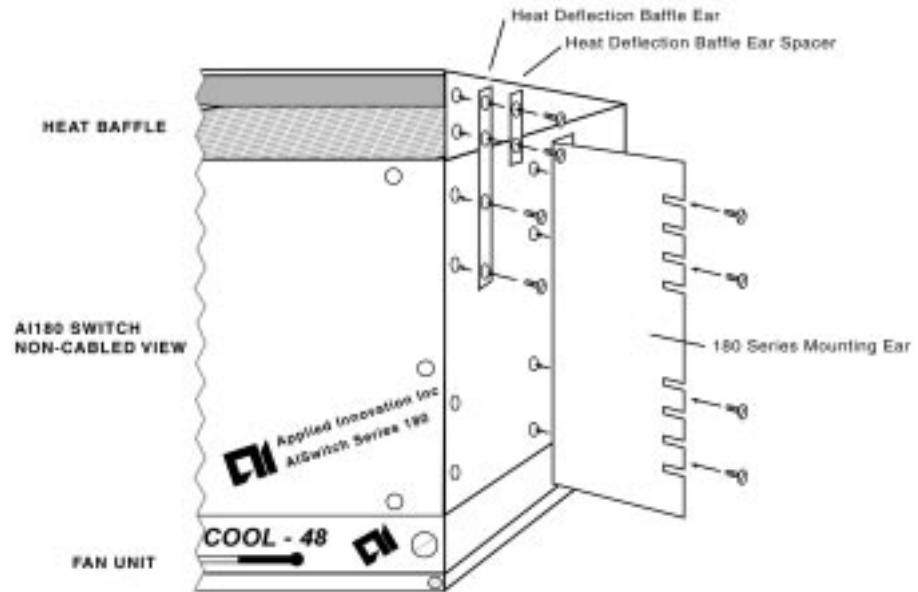

4. If mounting a second expansion chassis in the bay, the chassis with the AI198 must be mounted above the expansion chassis.
5. Complete the grounding connection between the chassis and the bay.  
Assure that the bay is properly grounded. If not, see the proper personnel to complete the bay grounding.
6. Select an appropriate length and gauge of grounding wire to run from the common alarm panel to the grounding point on the bay.  
Refer to local specified procedures for more information regarding ground wire sizing.
7. Crimp the grounding wire to the double-holed lug provided at one end and the appropriate bay lug at the other end.
8. Connect the lug to the common alarm panel and connect the other end of the wire to the bay using locally specified procedures.
9. Refer to steps [5](#) through [8](#) of this procedure to ground the expansion chassis.



**Caution:** Do not place any papers on top of the chassis ventilating holes. This restricts the air flow, and the chassis components may overheat.

## Replacing the AISwitch Series 180 Chassis

Use this procedure to replace the AISwitch Series 180 chassis. The chassis may need to be replaced:

- To update to a more ventilated chassis
- If the metal housing is damaged by some other piece of equipment
- To upgrade or replace parts

Before replacing the chassis itself, the chassis components must be removed from service. The replacement instructions list how to properly remove the components from service. Refer to the following components for instructions on removing or replacing the chassis components.

**Table 4-2: References for Chassis Components**

Chassis Component	Reference
Power supplies	RDC180-P Power Supply RDC180-HP Revision B Power Supply AI325-AC Power Supply
Common alarm panel	RDC180-C Common Alarm Panel
AI180 backplane	AISwitch Series 180 Chassis Assembly



**Caution:** Make sure the power to the chassis is turned off at the fuse panel before attempting to disconnect power to the chassis.

When replacing the chassis, service to the bay is interrupted for about 60 minutes. Use this procedure to replace the chassis enclosure.

1. Remove all the chassis components from service. Turn off the power supplies one at a time; remove the power connection to the chassis.
2. Remove the chassis to bay ground connection.
3. Remove the chassis components observing proper antistatic handling procedures.
4. Remove the chassis mounting screws while supporting the weight of the chassis. A second person is recommended at this point.
5. Remove the chassis and replace with the new chassis. Refer to the section on [Installing the AISwitch Series 180 Chassis](#).
6. Follow the installation steps listed above to complete the installation of the replacement chassis components.

## Installing the Heat Baffle

The heat baffle is required when installing an AICOOL-48 Fan Unit. This baffle deflects the air flow at the top of the chassis away from the components loaded in the mounting rack above the chassis. It also directs the air flow away from any personnel who may be working on the cabled side of the chassis.

**Note:** The heat baffle may already be installed on the AI180 chassis.

**Table 4-3: Heat Baffle Technical Specifications**

Specification	Description
Height	2 in. (5.08 cm)
Width	16.9 in. (42.9 cm)
Depth	10 in. (25.4 cm)
Weight	Approximately 3.18 pounds (1.44 kg)
Material	20 gauge steel with mounting holes for front center or rear rack mounting
Power Requirements	None
Operating Environment	0 ° C to 50 ° C 0 to 95 % relative humidity, non-condensing
Mounting Data	Mounting ears available to mount the baffle to the chassis



**Caution:** Before installing the heat baffle, put on a grounded, antistatic wrist strap. Read the [Static Electricity \(ESD\)](#) component for more details.

**Note:** The temperature sensor attachment is recommended as an extra precaution against heat damage to your chassis or cards. See the [AICOOL-48 Fan Unit](#) component for installation instructions.

1. Place the heat baffle on top of the AI180 chassis so that the open edge faces the noncabled side of the chassis.
2. Place the mounting straps over the screw holes provided in the baffle and install the screws.
3. Use the special spacers provided if the chassis or mounting rack dimensions vary enough to justify the need.
4. Align the screw holes from the straps to the chassis and install the screws.

Refer to the [AICOOL-48 Fan Unit](#) component for more details about the heat deflection baffle maintenance, parts replacement, and heat sensing thermocouple installation.

**Figure 4-3: Heat Baffle Installation**

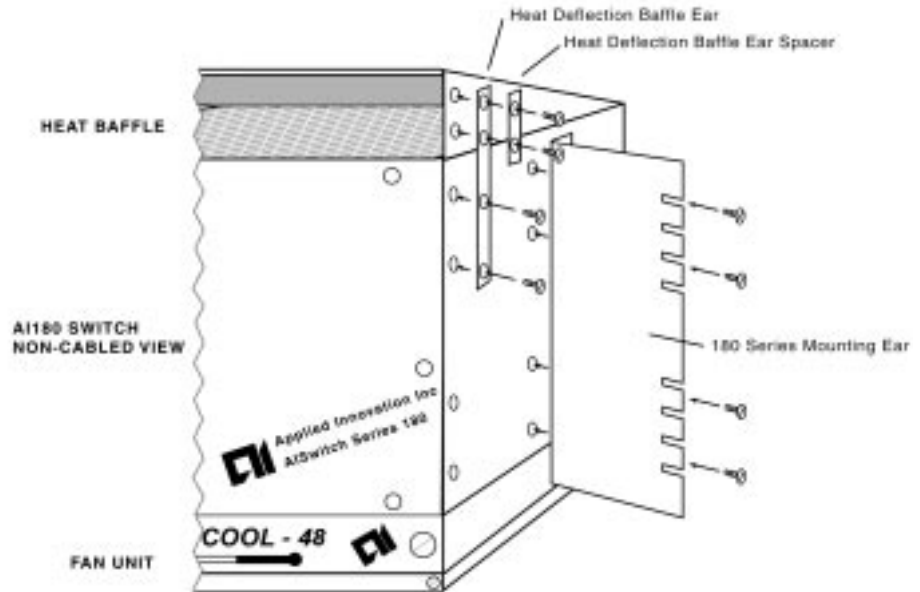



## Replacing the Heat Baffle

Service to the bay is not interrupted during replacement of a heat baffle.



**Caution:** Before installing the heat baffle, put on a grounded antistatic wrist strap. Read Appendix A [Static Electricity \(ESD\)](#) for more details.

1. Remove the screws from the mounting brackets on the sides of the installed baffle.
2. Remove the heat baffle from the bay.
3. Set the new heat baffle in place and tighten the mounting bracket screws.
4. If removing the heat baffle and thermocouple assembly, disconnect the thermocouple wire from the alarm monitoring unit and remove the thermocouple cable from the cable clamps.
5. Remove the screws from the mounting brackets on the sides of the installed baffle only.
6. Remove the heat baffle with its attached thermocouple.
7. Set the new heat baffle and thermocouple assembly in place and tighten the mounting bracket screws.
8. Attach the thermocouple wire to the alarm monitoring unit.
9. Replace the cable clamps.

Refer to the [AICOOL-48 Fan Unit](#) component for more details about the heat baffle maintenance, parts replacement, and heat sensing thermocouple installation.



**Caution:** Do not place any papers on top of the chassis ventilating holes. This restricts the air flow, and the chassis components may overheat.

**Installing/  
Replacing Nylon  
Card Glides**

The nylon-grooved slides for the network cards, if damaged, can be replaced. Use this procedure to replace the nylon glides.

1. Pry the nylon glide from its position using any non-conductive flat-edged tool.
2. Press a new slide into the same position.
3. Pop the three retainers on the bottom of the nylon slide into the holes on the metal plates in the chassis.

## Installing/ Replacing the Craft Port Connection

The craft port connection is used to access system configuration menus and commands on the CLC for a terminal connected to this port can locally configure the AI180. The craft port connection is located on the far left side of the cabled face of the chassis. This connection is an RS232 DB25 female connector.

The installation of the internal craft port cable requires an interruption of service to the system. This interruption occurs for about 60 minutes when the craft port cable is replaced due to the required removal of the backplane. A replacement backplane must be available to restore service to the bay since the craft port cable and backplane assembly must be returned to the factory for service or replacement.

Refer to the [Replacing the Backplane](#) section for more details.

### How to Install the Craft Port Cable

**Note:** Perform this procedure under the supervision of an Applied Innovation Field Technician.

1. Mount the DB25 female connector to the left side of the cabled face of the chassis housing with the 3/16 standoffs and nuts provided.

Refer to [Figure 4-1](#) for the location of the craft port.

### How to Replace the Backplane/Craftport Assembly

Use this procedure to replace the backplane/craft port assembly. The backplane, backplane mounting chassis, and craft port cable are treated as one assembly.

Do not attempt to remove the craft port cable from the backplane.

1. Remove the 3/16 standoffs and nuts mounting the DB25 female connector to the left side of the cabled face of the chassis.
2. Refer to the [Replacing the Backplane](#) section for more details.
3. The backplane/craftport assembly must be returned to Applied Innovation Inc. for service or replacement.

## Replacing the Backplane

When the backplane is shipped from the factory, the PCB board is fastened to the inside of the non-cabled face of the chassis with 12 machine screws. Do not remove the backplane PCB board from the chassis panel. Under normal configurations, the backplane ships with the internal IRB bus not split.

The IRB switches on the backplane can effectively split the IRB bus (the internal Ethernet bus) into two isolated 4-slot segments or remain as one 8-slot segment. This split would be done to:

- Segment a LAN for throughput
- Maintain independent ethernet segments within the same chassis

**Table 4-4: Backplane Technical Specifications**

Specification	Description
Width - PCB only - Attached chassis panel	9.115 in. (23.15 cm) 11.85 in. (30.1 cm)
Length - PCB only - Attached chassis panel	15.185 in. (38.56 cm) 16.6 in. (42.16 cm)
Weight - Attached to chassis panel	Approximately 4.4 lbs. (2.0 kg)
Material	20-gauge steel, FR4 epoxy glass PCB
Power Requirements	+5 V, -12 V, +12 V
Operating Environment	0 ° C to 50 ° C 0 to 95% relative humidity, non-condensing
Mounting Data	Fastens to the chassis panel with 12 machine screws.   <b>Caution:</b> DO NOT REMOVE the backplane from this panel.

Figure 4-4: AISwitch Series 180 Backplane



## Backplane Jumper Settings

The following jumper settings are factory defaults for the Revision 10 backplane. Refer to these settings in the event that the default settings change by accident.

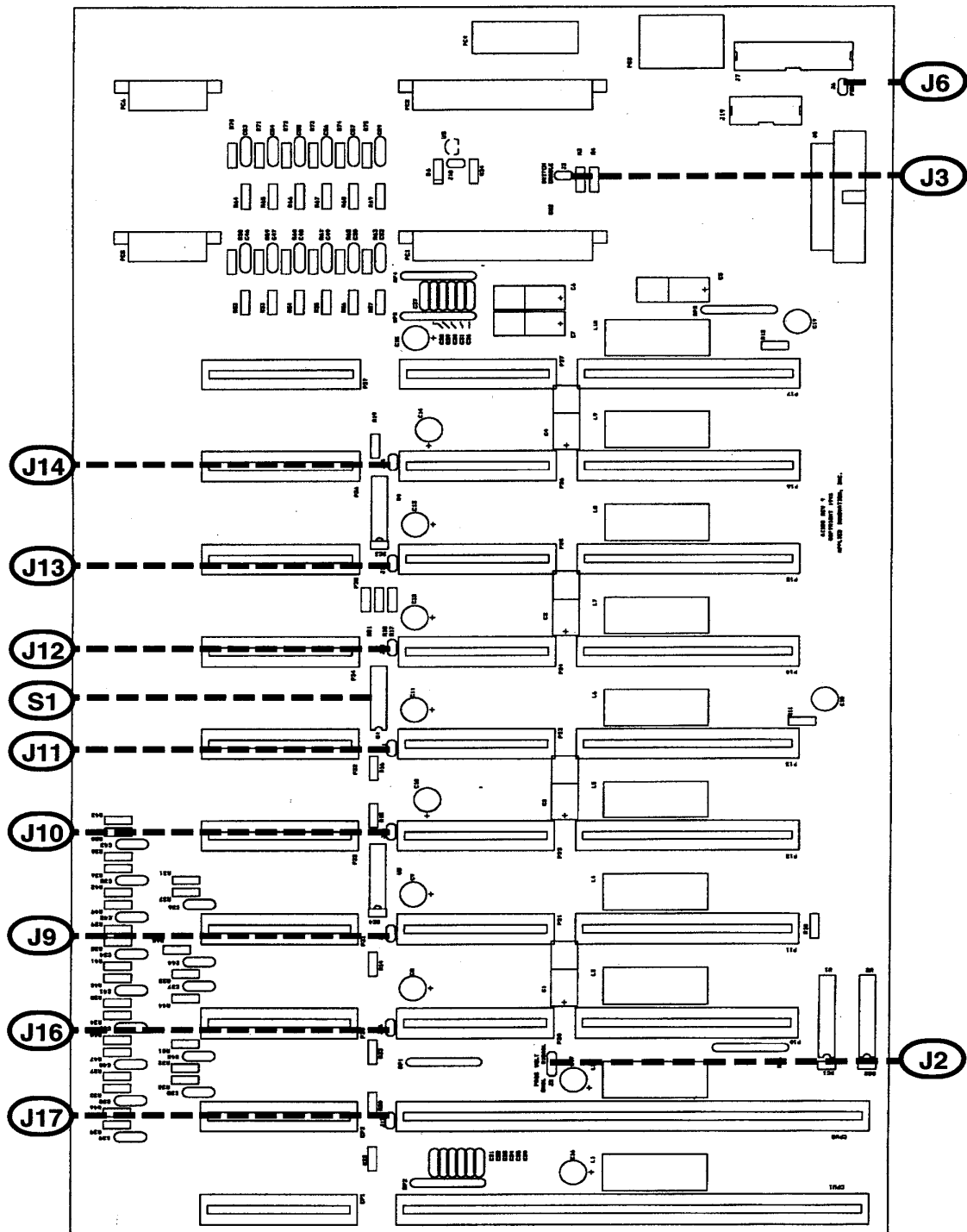

**Caution:** Do not change jumpers on the motherboard. If you do, the backplane may not function properly.

**Table 4-5: Default Revision 10 Backplane Jumper Settings**

Jumpers	Description
J2	Installed on 2-3
J3	Shorted (Switch Enabled)
J6	Removed
J9	Removed
J10	Removed
J11	Removed
J12	Removed
J13	Removed
J14	Removed
J16	Removed
J17	Removed
S1	All On (Closed)

## Removing the Backplane

Replacement of the backplane interrupts service to the bay for about 60 minutes. A replacement backplane assembly must be available to restore service to the bay since the backplane/craftport assembly must be returned to the factory for service or replacement.

1. Remove all chassis components from service. Refer to the individual user's manual for each card or component for specific commands to remove the card or component from service.
2. Remove fuses which service the AI180 from the fuse panel supplying the power.
3. Remove the incoming power supply cables to the chassis.
4. After removing the chassis components from service, pull the cards, and power supplies forward to release each component from the backplane connection. The cards do not have to be completely removed from the chassis shell but can sit loosely in their slots. Observe proper antistatic handling procedures for the components.
5. Remove the Common Logic Cards A and B. Temporarily store these cards following ESD procedures.
6. Remove the 3/16 standoffs and nuts that retain the craft port's DB25 female connector to the chassis housing.
7. Slide the craftport's ribbon cable out of the plastic retainers located inside the chassis on the left side.
8. From the non-cabled side of the chassis, remove the eight 4-40 Phillips-head screws holding the backplane/craftport panel to the chassis.
9. The Common Alarm Panel will be connected to the backplane. Partially remove the backplane/craft port panel for accessibility to the Common Alarm Panel ribbon cable.

Disengage the common alarm panel ribbon cable located in the bottom left corner of the assembly which is connected to connector J7.

10. Return the backplane and craft port connection cable chassis panel assembly to the factory for replacement. Do not attempt to remove the backplane PCB board from the chassis panel.

## Replacing the Backplane

1. Position the replacement backplane so that the left edge aligns with the left edge of the non-cabled side of the chassis and the right edge is approximately eight inches from the right edge of the chassis.
2. Place the craft port cable into the chassis.
3. Insert the alarm panel ribbon cable connector into the backplane connector J7 located at the bottom left corner of the backplane/craft port assembly.
4. Set the backplane/craftport assembly onto the ledge formed by the outer chassis.
5. Confirm that the backplane/craft port assembly lies flat against the chassis face.
6. Insert the eight 4-40 phillips head retaining screws into the backplane/craft port assembly from the non-cabled side of the chassis.
7. From the cabled side of the chassis, slide the craft port ribbon cable into the plastic retainers located inside the chassis on the far left side.
8. Use the 3/16 threaded standoffs to install the craft port connector in to the DB25 chassis craft port.
9. Return the replaced backplane/craft port assembly to the factory in the same or equivalent shipping materials.



**Caution:** Do not attempt to remove, replace, or repair the backplane/craft port assembly in the field.



## Installing the AI198 Common Logic Card

The Common Logic Card (CLC) and redundant CLC install in slot A and B of the chassis. The CLCs are located on the cabled side of the chassis. This procedure requires local or remote terminal access to the AI180 System.

1. Insert the CLC card into slot A or B. To locate slots A and B, refer to [Figure 4-5](#).

**Figure 4-5: AI198 CLC Slot Assignment**

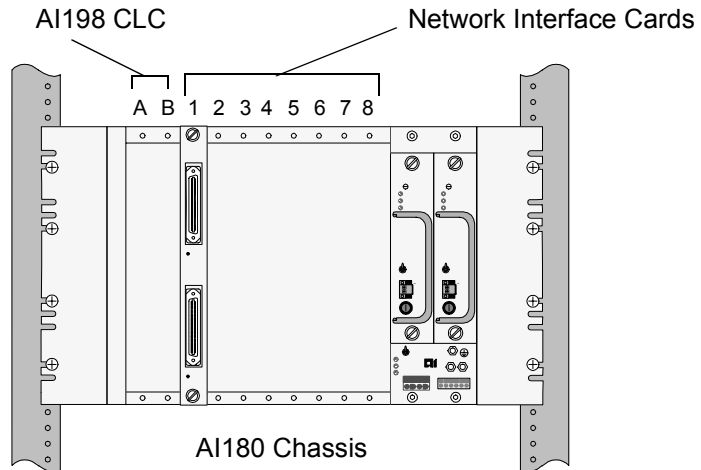

2. Push the card firmly until you hear a slight click that indicates a solid connection to the backplane.
3. Tighten the mounting screws.
4. Refer to the *AI198 System Manager/User's Manual* for configuration instructions.

## Installing/ Replacing a Network Interface Card

Refer to the [AI180 Hardware Overview](#) component for a list of the possible cards which may be installed in the chassis. It is not necessary to remove the power to the chassis card before changing the card. Changing an interface card removes the card from service for about two minutes. This is referred to as a Hot Swap procedure.

**Note:** This procedure requires local or remote terminal access to the AI180 System.

1. If the card is functioning, remove the card from service using the appropriate CLC `stpslc` and `disabl` commands. Refer to the *AI198 System Manager/User's Manual* for details regarding these commands.
2. Disconnect cables attached to the card.
3. Loosen the mounting screws on the card.
4. Pull the card forward until it releases from the backplane.
5. Remove the card observing proper anti-static handling procedures. Check the table inside to see if there is a special note for the card you are installing (e.g., jumper settings).
6. Align the new card to the plastic guides in the chassis.
7. Insert the new card into a slot (1 to 8). To locate slots 1 to 8, refer to [Figure 4-6](#).

**Figure 4-6: Slot Assignments**

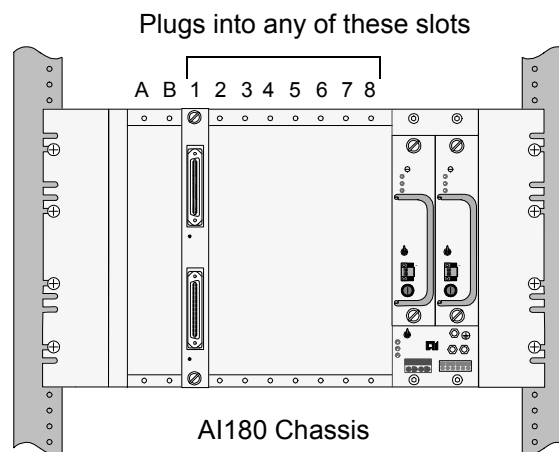

8. Push the card firmly until you hear a slight click that indicates a solid connection to the backplane.
9. Tighten the mounting screws to assure that the card is firmly inserted into the backplane.

10. Make sure that the green LED light labeled DC OK illuminates.
11. Connect the appropriate cables to the card or distribution panel if necessary  
Refer to the *AI198 System Manager/User's Manual* for information on configuration.

**Replacing an Asynchronous Card**

See the *AI198 System Manager's/User's Manual* to replace an asynchronous card.

**Replacing a Smart Line Card**

See the *AI198 System Manager/User's Manual* to replace a Smart Line Card.



# Chapter 5: AI130 Hardware Overview

## Overview

The AISwitch Series 130 is a network mediation device that allows incompatible telecommunication network elements to communicate over a variety of Wide Area Networks (WANs).

The AI130 is like the larger AISwitch Series 180 only it is more compact, having fewer connections and ports. The AI130

- Uses one AI198 Common Logic Controller
- Accepts up to three interface network modules
- Uses an RDC130-C Common Alarm Panel
- Utilizes a different backplane
- Uses either an RDC180-P or AI325-AC Power Supply

This manual describes the AISwitch Series 130 chassis, the components that can be installed in the chassis, and additional hardware equipment which can be installed in the bay in the telecommunications facility.

The AISwitch Series 130 consists of one -48 volt power supply or two redundant -48 volt power supplies, a common alarm module and craft port, a grounding panel, a slot for an AI198 Common Logic Controller, and three slots for network cards. It can also operate with AC power.

## RDC180-P Power Supply

**Figure 5-1:**  
**RDC180-P Faceplate**

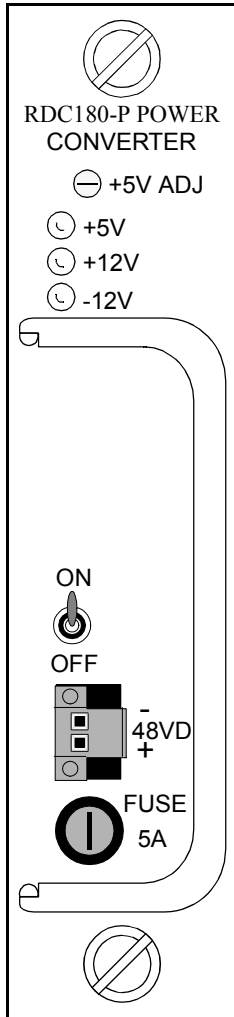

The RDC180-P is used in an AI130 chassis where the +5 volts DC power consumption is less than 14.9 amps. Each RDC180-P occupies a single power supply slot. Two RDC180-P DC power supplies are used in a chassis to provide redundant power if one of the units should fail in service. See the [Calculating Chassis Power Consumption](#) appendix for the formulas used to compute the power used by the components of a chassis.

Designed to operate with a DC input voltage between -39 volts DC and -63 volts DC, the RDC 180-P should utilize a nominal input voltage of -48 volts DC. This power supply converts the incoming -48 volts DC power to the +5 volts, +12 volts, and -12 volts DC needed for the individual network interface cards installed in the chassis.

Refer to the [RDC180-P Power Supply](#) component for more details regarding the RDC180-P technical specifications, installation, and replacement.

## AI325-AC Power Supply

The AI325-AC power supply is positioned in the chassis above the RDC130-C Common Alarm Panel. The AI325-AC occupies two power supply slots. This power supply converts the incoming 120V AC power to the +5 volts, -12 volts, and +12 volts DC needed by the chassis components.

**Figure 5-2: AI325-AC Power Supply Faceplate**

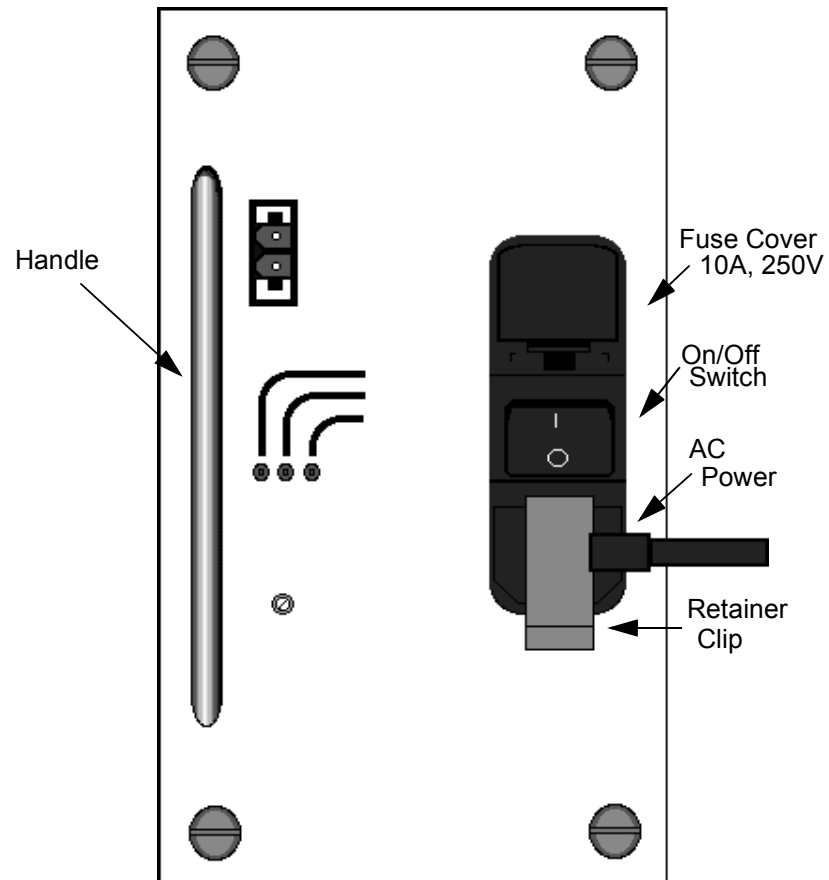

Refer to the [AI325-AC Power Supply](#) component for more details regarding the AI325-AC technical specifications, installation, and replacement.

## RDC130-C Common Alarm Panel

**Figure 5-3:**  
**RDC130-C Common  
Alarm Panel**

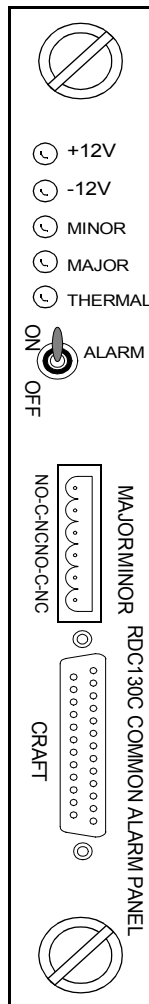

The RDC130-C Common Alarm Panel provides an external alarm interface for the AI130. It includes major, minor, and thermal alarm indicators. The alarm panel can also indicate AISwitch software alarm conditions.



**Caution:** Do not remove the common alarm panel. Captive screws on the common alarm panel are for factory use only.

### Input Connections

The alarm panel does not need external input connections to indicate alarm conditions.

### Output Connections

The MAJOR and MINOR alarm relays terminate on the Alarm Panel modular connector. The connections include the following:

- The C designation is for the common contact pin for each relay.
- The NC connection is normally closed, contacting the C pin. The connection is open or disconnected from the C pin when there is an alarm.
- The NO connection is normally open, not contacting the C pin. The connection is closed or connected to the C pin when there is an alarm.

### Alarm Indicators

The RDC130-C uses three red LEDs to indicate alarms. They are MINOR, MAJOR and THERMAL on the panel. An alarm does not halt AISwitch operations. Indicators alert the user that an alarm condition exists. If an alarm occurs, one or more red LEDs will be illuminated. They will not illuminate under some alarm conditions if the +5 VDC power fails. If you switch ON the AUDIBLE ALARM, an audible alarm will sound during a major alarm.

The system has a thermal sensor that triggers the THERMAL alarm if the internal temperature exceeds approximately +55 degrees Celsius. This alarm condition does not halt the AISwitch.

Refer to the [RDC130-C Common Alarm Panel](#) chapter for a complete listing of alarm conditions.



**Grounding Panel**

The grounding panel separates the power and alarm panels from the CLC and interface card slots. It has the following connectors:

- |             |   |
|-------------|---|
| GROUND      | Two ground studs provide the frame grounding for the AI130. Connect them to a suitable ground such as the frame ground of the rack system or a reliable earth ground point. |
| WRIST STRAP | Connect your anti-static wrist strap here. You must follow anti-static procedures when you work on the AISwitch or its components.  |

## AI198 Common Logic Controller

The AI130 uses one AI198 Common Logic Card installed in the top right slot of the AI130. It provides SNMP, telnet, FTP, and software download capabilities. Refer to the *AI198 System Manager/User's Manual* for more details regarding the configuration of the AI198 CLC.



**Caution:** Do not put any card except the AI198 CLC card into the top right slot of the AI130 chassis. Damage to the network card will result.

**Network  
Interface Card  
Slots 1 Through 3**

The AI130 enclosure has three slots for interface cards. These slots are the bottom three on the right side of the chassis. They will accept any AI port or network interface card except the AI294. Refer to the [AISwitch Series 180 Chassis Assembly](#) component for a description of the interface cards.



# Chapter 6: AISwitch Series 130 Chassis Assembly

## Overview

This component lists how to install or replace the AISwitch Series 130 chassis, mounting ears, AI198, and interface cards along with component location and technical specifications.

For configuration details on each of the chassis cards supported, refer to the User's Manual for the specific card and the *AI198 System Manager/User's Manual*.

## Electrostatic Warning

The AISwitch contains electrostatic sensitive components. Proper handling, shipping, and storage precautions must be exercised.

- Removal and installation of circuit boards must be performed in a static-free environment. A technician should wear an anti-static wrist strip and stand on an anti-static mat. Both the wrist strap and mat must be grounded at the same point as the AISwitch enclosure.
- When not in use, circuit boards must be kept in their anti-static plastic bags.
- Circuit boards must only be removed from their anti-static plastic bags immediately prior to installation into the AISwitch enclosure.
- Immediately upon removal from the enclosure, circuit boards must be inserted into their anti-static bags.
- Do not ship or store the electronic circuit boards near strong electrostatic, electromagnetic, magnetic, or radioactive fields.

## Unpacking

Unpack the enclosures and cards placing them on a static-free work area. Inside the packaging you will find the rack mounting brackets (AI Part 06-140-007) and the power cord (if your system operates on AC power). To install or adjust the settings of the cards in your system, remove the blank cover plates from the cabled side of the unit if necessary.

If you are going to mount the system in 23 inch rack, proceed to the section regarding [Rack Mounting](#). If you are going to place the system on a shelf or on top of an existing structure, proceed to either the [RDC180-P Power Supply](#) component or the [AI325-AC Power Supply](#) component.

**Figure 6-1: AISwitch Series 130**

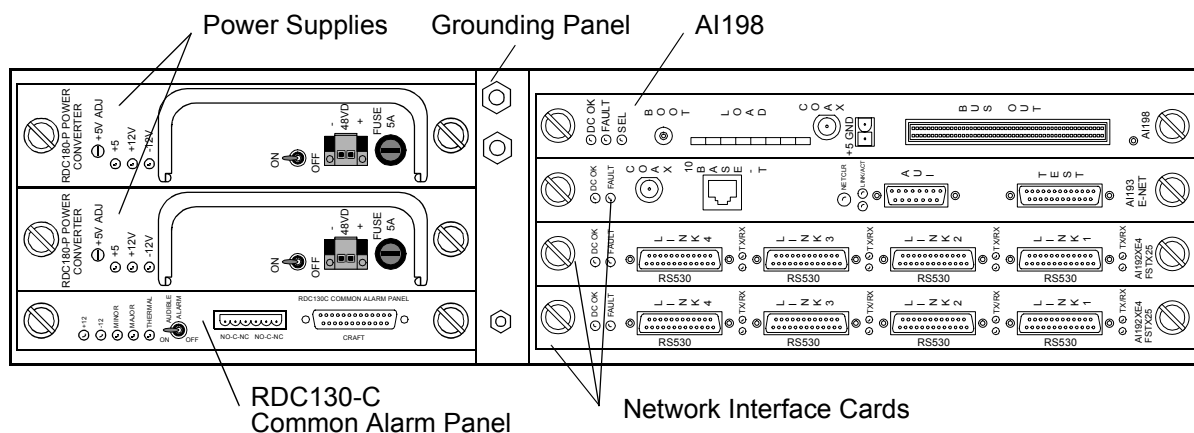

Table 6-1: AI130 Chassis Technical Specifications

Specification	Description
Network Cards	Use one to three AI port or network interface cards.
Dimensions	Height: 5.22 in.(13.26 cm) Width: 21 in. (53.34 cm) Depth: 9.76 in. (24.79 cm)
Weight	Approximately 25 lb. (11.34 kg) which includes dual DC power supplies, three cards, and a common logic controller.
Power Supplies	The AISwitch 130 operates on one of two power supply options: <ul style="list-style-type: none"> <li>● RDC180-P. A -48 VDC power supply which will also operate in the larger AI180 in Telco applications with single or redundant configurations.</li> <li>● AI325-AC. A non-redundant power supply for 102 to 264 VAC, 47 to 63 Hz, and 325 W.</li> </ul>
Mounting Data	Mounting ears (AI Part 06-140-007) available to mount the chassis to a 23 in. (58.42 cm) rack

## Rack Mounting

These instructions refer to a typical chassis which includes pre-installed chassis cards, power supplies and the common alarm panel. Use this procedure to install the mounting ears in the desired position, mount the chassis in the bay, and properly ground the chassis.

1. Install the mounting ears (AI Part 06-140-007) on the chassis in the proper position using the philips flat head machine screws provided (AI Part 00-010-002).
2. Place the chassis in the bay installation location after attachment of the mounting ears. There are many possible positions for mounting the chassis. Refer to the local specifications of the telecommunications facility for the proper position.

Two people are recommended at this point. One holds the chassis with the attached mounting ears in position while the other fastens the ears to the bay flange with the phillips pan head machine screws provided (AI Part 00-015-003).

3. Complete the grounding connection between the chassis and the bay.  
Assure that the bay is properly grounded. If not, see the proper personnel to complete the bay grounding.
4. Select an appropriate length of grounding wire to run from the AI130 chassis to the grounding point on the bay.
5. Crimp the grounding wire to the double-holed lug provided at one end, and the appropriate bay lug at the other end.
6. Connect the lug to the AI130 chassis and connect the other end of the wire to the bay using locally specified procedures.



**Caution:** We recommend you do not use the AISwitch 130 with expansion enclosures. When you need additional network capacity, use the AISwitch 180.



## Installing the AI198 Common Logic Card

The Common Logic Card (CLC) and redundant CLC install in upper right top slot of the chassis. The CLCs are located on the cabled side of the chassis. This procedure requires local or remote terminal access to the AI180 System.

1. Insert the CLC card into upper right top slot. To locate the slot, refer to [Figure 6-2](#).

**Figure 6-2: AI198 CLC Slot Assignment**

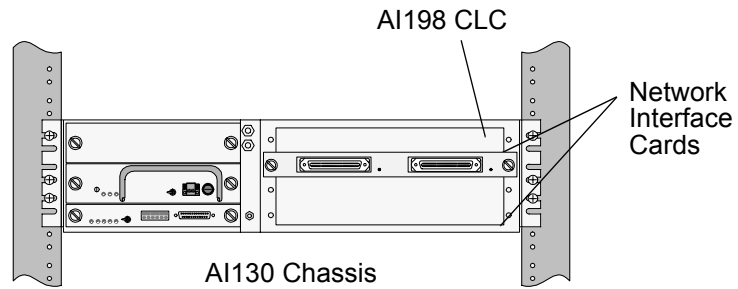

2. Push the card firmly until you hear a slight click that indicates a solid connection to the backplane.
3. Tighten the mounting screws.
4. Refer to the *AI198 System Manager/User's Manual* for configuration instructions.

## Installing Network Interface Cards

Refer to the [AI130 Hardware Overview](#) component for a list of the possible cards which may be installed in the chassis.

1. Find an empty slot (one without a network interface card present) and detach the cover plate by loosening the two captive screws.
2. Place the interface card into the slot (1 to 3) so that the gold-plated fingers are at the right. Refer to [Figure 6-3](#) for the slot location.

**Figure 6-3: Network Interface Card Slot Assignments**

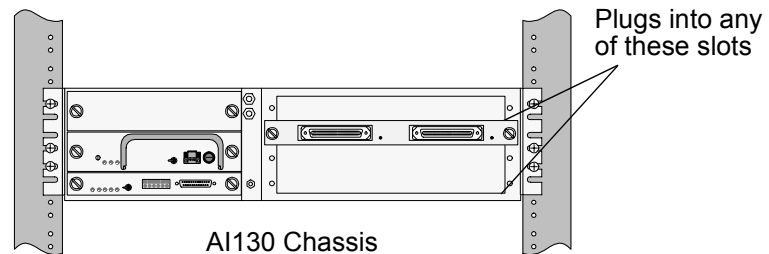

3. Slide the card in all the way until you feel the connector engage and the cover plate is flush with the enclosure.
4. Tighten the two captive screws on the cover plate.

## Replacing an Asynchronous Card

See the *AI198 System Manager/User's Manual* to replace an asynchronous card.

## Replacing a Smart Line Card

See the *AI198 System Manager/User's Manual* to replace a Smart Line Card.

## Connecting a Terminal

Connect the terminal to the “CRAFT” port for system configuration.

If you are using a “dumb” CRT terminal, you only need to have pins 2 (to transmit data), 3 (to receive data), and 7 (signal ground) connected. If your cable does not work, the most probable cause is that the signals on pins 2 and 3 need to be reversed. Try correcting this first.

The AISwitch is shipped from the factory with craft port initially configured at 9600 baud, 8 bit, no parity, 1 stop bit.

When the system starts up, you will see a list of one or more messages. The number and content of these messages will vary according to the cards in your system. See the *AI198 System Manager/User's Manual* for more information on these messages.



# Chapter 7: Interface Card Hardware Specifications

## AI120

This section describes the AI120 printed circuit boards, controls, and indicators.

The AI120 is a single-board, microprocessor-based monitor system for binary (contact) inputs. It provides 64 optically isolated alarm inputs for contact closures. Refer to the Installation chapter of the *AI120 Contact Alarm Monitor User's Manual* for more information. The AI120 also provides 10 relay outputs (normally open or normally closed) for connection to local alarm inputs. Refer to the Installation chapter of the *AI120 Contact Alarm Monitor User's Manual* for more information. The outputs can be individually or multiply linked to input points. The AI120 provides two serial ports. One serial port is for TL1 messaging with the NMA, and the other is a local port.

### AI120-64SA Power Supply

The power supply board for the AI120-64SA provides redundant -12 VDC outputs and accepts dual -48 VDC power inputs, which are independently fused. The parallel switch-mode supplies on the board are both fed from both -48 VDC inputs and -12 VDC outputs and are tied together.

If one of the power supply circuits fails, the second is capable of carrying the entire AI120 load. A failure of either input power main or a fuse will not interfere with AI120 operation. The input voltage range is -40 VDC to -60 VDC.

An LED is provided for each half of the redundant power supply circuits to indicate operation. A continuously illuminated LED indicates normal operation.

**Note:** The AI120 is in a normal condition state when it is fully powered and not in an alarm state.

### AI120-64IF Faceplate and Connectors

The following describes the faceplate and connectors associated with the AI120-64IF

**Figure 7-1: AI120-64IF Faceplate**

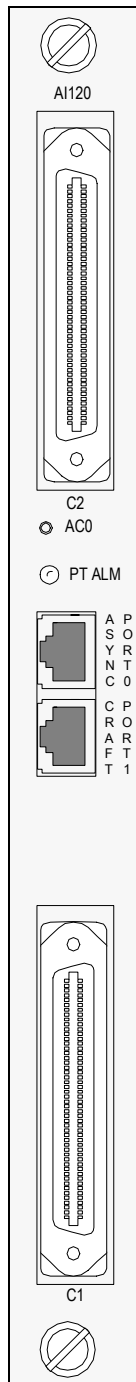

**I/O Connectors C1 & C2**

The 64 alarm inputs and 10 relay outputs are connected via the two, 50-pin connectors (C1 and C2) on the AI120 faceplate via an external wiring block (DP120). The DP120 allows wire-wrap connection of wiring. Refer to the I/O Wiring chapter of the *AI120 Contact Alarm Monitor User's Manual* for wiring instructions.

**Async Craft Port 0 & Craft Port 1**

Two RJ45 connectors provide serial interfaces to the AI120. Both ports provide identical functions. In the AI120-64IF, one of the ports connect to the AI180 for alarm reporting. In the AI120-64SA, one of the ports can be connected to a separate AI180 or to an external modem for alarm reporting. The other port can be used as a local port for configuration. Refer to the Serial Port Wiring chapter of the *AI120 Contact Alarm Monitor User's Manual* for serial port connector wiring. AI cable # CAB197 is designed for direct connection from the AI120 to a PC.

**PTALM Indicator**

The PTALM indicator is continuously illuminated when no alarm condition exists. When an alarm condition exists, the PTALM indicator flashes. The PTALM indicator also flashes when the ACO button is pressed, indicating that the AI120 is in normal operation.

**Alarm Cutoff (ACO)**

When an alarm occurs, the AI120 transmits a TL1 message to the NMA. It also sets a relay for local alarm purposes (if programmed to do so). The ACO (alarm cut off) button releases all engaged relay outputs. The PTALM indicator on the AI120 continues to flash until all alarm inputs return to their normal state.

The ACO button is also used to test AI120 operation. Under normal conditions, with no alarms present, the PTALM indicator is continuously illuminated. When the ACO button is pressed, the PTALM indicator flashes if the AI120 processor is operating.

## AI120-64SA Enclosure

The following describes the faceplate and connectors associated with the AI120-64SA Enclosure. The stand-alone AI120-64SA has the AI120-64IF interface installed in a metal rack. In addition to the faceplate connectors, the stand-alone enclosure has additional controls and indicators.

**Figure 7-2: AI120-64SA Enclosure**

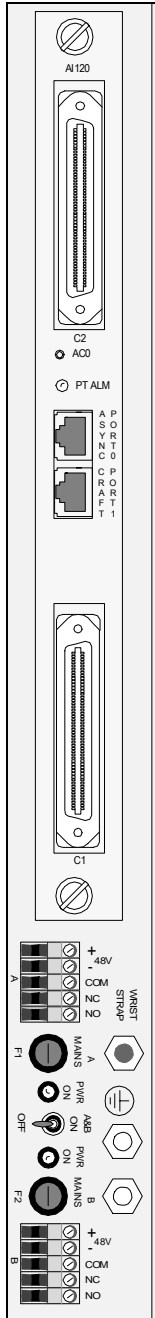

**A and B -48 VDC Power Terminals**

Two separate CO -48 VDC power mains are connected to these terminals to provide redundant power.

**A and B Fuses**

Each CO power main is individually fused on the AI120-64SA.

**Power Switch**

This switch turns -48 VDC power on and off to both redundant power supplies in the AI120-64SA.

**A and B Indicators**

When lit, these indicate that the A and B redundant power supply circuits in the AI120 stand-alone enclosure are providing output power for the AI120. If either indicator is not lit, the associated power supply circuit is not functioning.

**Power Supply Alarm Contacts**

The A and B sides of the redundant power supply each provide independent alarm contacts for failure detection. Normally Open (NO) and Normally Closed (NC) contacts are provided, sharing a common terminal. When the power supply is operating normally, the NO contacts are open and the NC contacts are closed.

The installer can wire the contacts separately or in parallel as a single alarm.

**AI120 System Ground**

A jumper on the AI120-64SA power supply connects the AI120 power supply ground to the enclosure which is connected to a frame ground. This jumper can be removed if isolation is required. To connect the power ground, remove the AI120-64SA top cover and install the J2 jumper shunt on the power supply board near one of the mounting screws. The AI120-64SA is shipped with J2 in the ISOLATED position.

## AI182

The AI182 is an AI180 expander logic module. The AI182 is typically used when more than one chassis is needed.

**Figure 7-3: AI182 Faceplate**

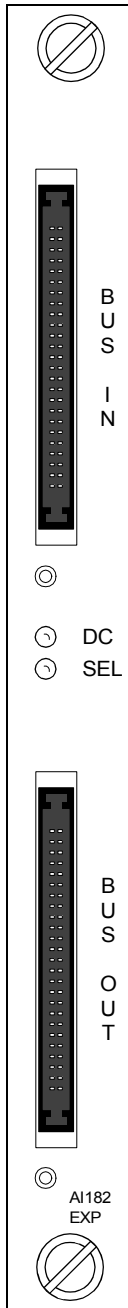

.For systems with two or more chassis, slots A and B of the expander chassis hold the expander cards. The AI182 provides CLC bus expansion from the controller CLC to the expander chassis.

If you have only one CLC in the controller chassis, then you only need one expander card in each expander chassis. If you have two CLCs in the controller chassis, then you need two expander cards in slots A and B of each expander chassis.

### AI182 Faceplate and Connectors

The following describes the faceplate and connectors associated with the AI182.

**DC**

When lit, this indicator light shows that the card has made contact with the backplane. This indicator light does not indicate that the card is fully seated.

**SEL**

When lit, this indicator light shows which CLC is working (either the CLC in slot A or the CLC in slot B).

**Connectors**

These two connectors, labeled BUS IN and BUS OUT, are used to connect to the CLCs to the expander chassis.

**Note:** Since the CLC in the controller chassis controls the entire system, the expander card does not include a processor or diagnostics.

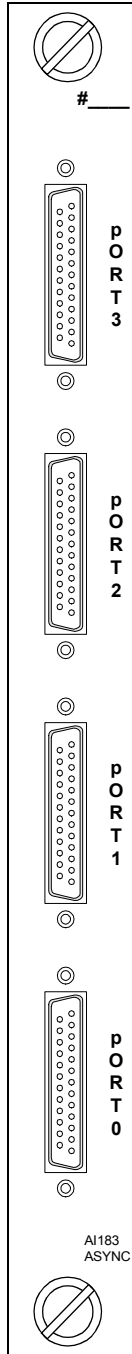

**AI183****Figure 7-4: AI183 Faceplate**

The AI183 is a standard four-port asynchronous interface card.

**AI183 Faceplate and Connectors**

The following describes the faceplate and connectors associated with the I183.

PORT 0	uses DTR and RTS for external alarm signaling
PORT 1	async interface for user access or application
PORT 2	async interface for user access or application
PORT 3	async interface for user access or application

**Technical Specifications**

- 4 ports numbered 0-3
- integral voltage surge protection
- 25-pin standard termination
- RS-232
- electrical DTE pin configuration
- supported EIA outputs: DTR, RTS, TXD (pin 3)
- supported signal inputs: DSR, RXD

## AI185

The AI185 interface card provides 16 asynchronous connections to the AISwitch Series 180 (AI180) or the AISwitch Series 130 (AI130). The interface connects user terminals, personal computers, modems, and host computer ports to the AI180 or AI130. All ports have modem control for host or modem applications. The AI185 requires a distribution panel for the physical interface.

**Figure 7-5: AI185 Faceplate**

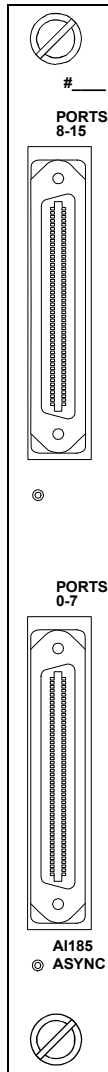

### AI185 Faceplate and Connectors

The following describes the faceplate and connectors associated with the AI185.

PORTS 0-7 connector	50-pin connector used to connect Ports 0-7 to the distribution panel.
PORTS 8-15 connector	50-pin connector used to connect Ports 8-15 to the distribution panel.

### Technical Specifications

- Sixteen async, EIA-232 I/O ports requiring a distribution panel for the physical interface.
- Selectable baud rates for each port (50 to 19200).
- Supported electrical interfaces for Revision 5 include the following:  
EIA outputs: DTR, RTS, TXD  
EIA inputs: DCD, DSR, RXD

**Note:** The AI185 Revision 5 provides either the DCD or RTS signal. The model of distribution panel used determines whether the DCD or RTS signal is active. Refer to the [Distribution Panels](#) chapter of this manual for more information.

- Supported electrical interfaces for Revision 3 and earlier include the following:  
EIA outputs: DTR, RTS, TXD  
EIA inputs: DSR, RXD
- Requires one slot in the AI180 or AI130 chassis. Can be hot swapped.

## AI192

This section contains information about hardware requirements, jumper settings, motherboard diagrams, and daughterboard layouts for the AI192 Revisions 4 and 5.

### AI192-XR4 and AI192-XE4 Faceplate and Connectors

**Figure 7-6: AI192-XR4 and AI192-XE4 Faceplate**

The following describes the faceplate and connectors associated with the AI192-XR4 and AI192-XE4. The AI192-XR4 uses X.25 protocol with RS232 communications. The AI192-XE4 uses X.25 protocol with RS530 communications.

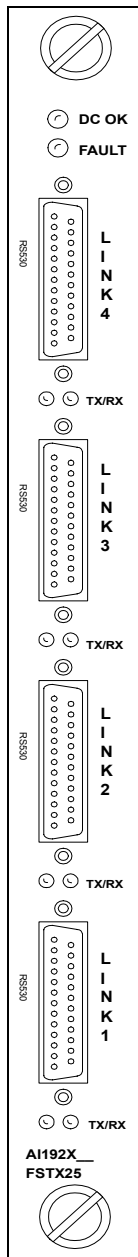

DC/OK

The green LED indicates the card is on and receiving DC power. If the red LED is illuminated, a fault has been detected.

FAULT

This red LED indicates a fault has been detected.

LINK 1

AI192-XE4 (RS530 connector)

AI192-XR4 (RS232 connector)

LINK 2

AI192-XE4 (RS530 connector)

AI192-XR4 (RS232 connector)

LINK 3

AI192-XE4 (RS530 connector)

AI192-XR4 (RS232 connector)

LINK 4

AI192-XE4 (RS530 connector)

AI192-XR4 (RS232 connector)

**Figure 7-7: AI192-XV1 Faceplate**

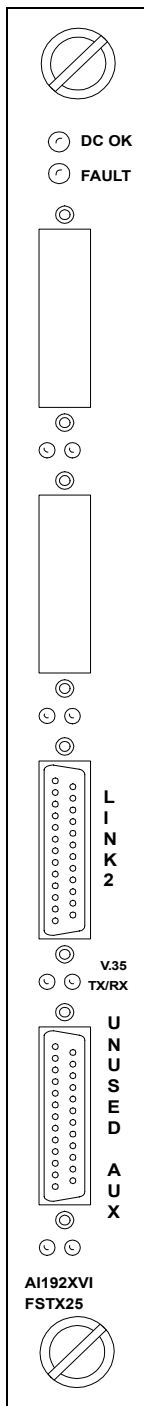

**AI192-XV1 Faceplate and Connectors**

The following describes the faceplate and connectors associated with the AI192-XV1. The AI192-XV1 uses the X.25 protocol with V.35 communications.

DC OK

This green LED indicates the card is on and receiving DC power.

FAULT

This red LED indicates a fault has been detected.

LINK 2

Link 2 is a V.35 connector.

UNUSED AUX

This connector is not used.

**Note:** You can use the `winslc set diagport on` command to activate this port.

**Figure 7-8: AI192-XT2 Faceplate**

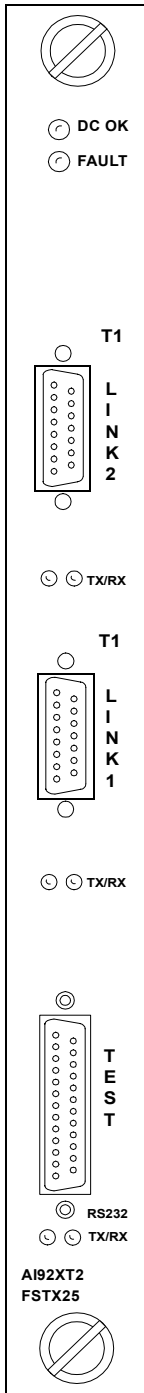

**AI192-XT2 Faceplate and Connectors**

The following describes the faceplate and connectors associated with the AI192-XT2. The AI192-XT2 uses the X.25 protocol with T1 communications.

- DC OK                                      This green LED indicates the card is ON and receiving DC power.
- FAULT                                      This red LED indicates a fault has been detected.
- LINK 2                                      Link 2 is a T1 connector.
- LINK 1                                      Link 1 is a T1 connector.
- TEST                                        This connector is not used.

## AI192 Revision 4 Jumper Settings

[Table 7-1](#) lists the AI192 Revision 4 jumper settings. Refer to these settings in the event that the default settings change by accident (e.g. the card falls on the floor and a jumper strap falls off).



**Caution:** Do not change jumpers on the motherboard. If you do, the card may not function properly.

**Table 7-1: AI192 Revision 4 Jumper Settings**

<b>Jumpers</b>	<b>Setting</b>
J2	Installed on 2-3
J3	Installed on 2-3
J5	Installed on 2-3
J8	Diagnostic port
J9	Installed on 2-3
J10	Installed on 1-2
J12	Installed

AI192 Revision 4 Board Layout

Figure 7-9 displays the AI192 Revision 4 board layout.

Figure 7-9: AI192 Revision 4 Board Layout

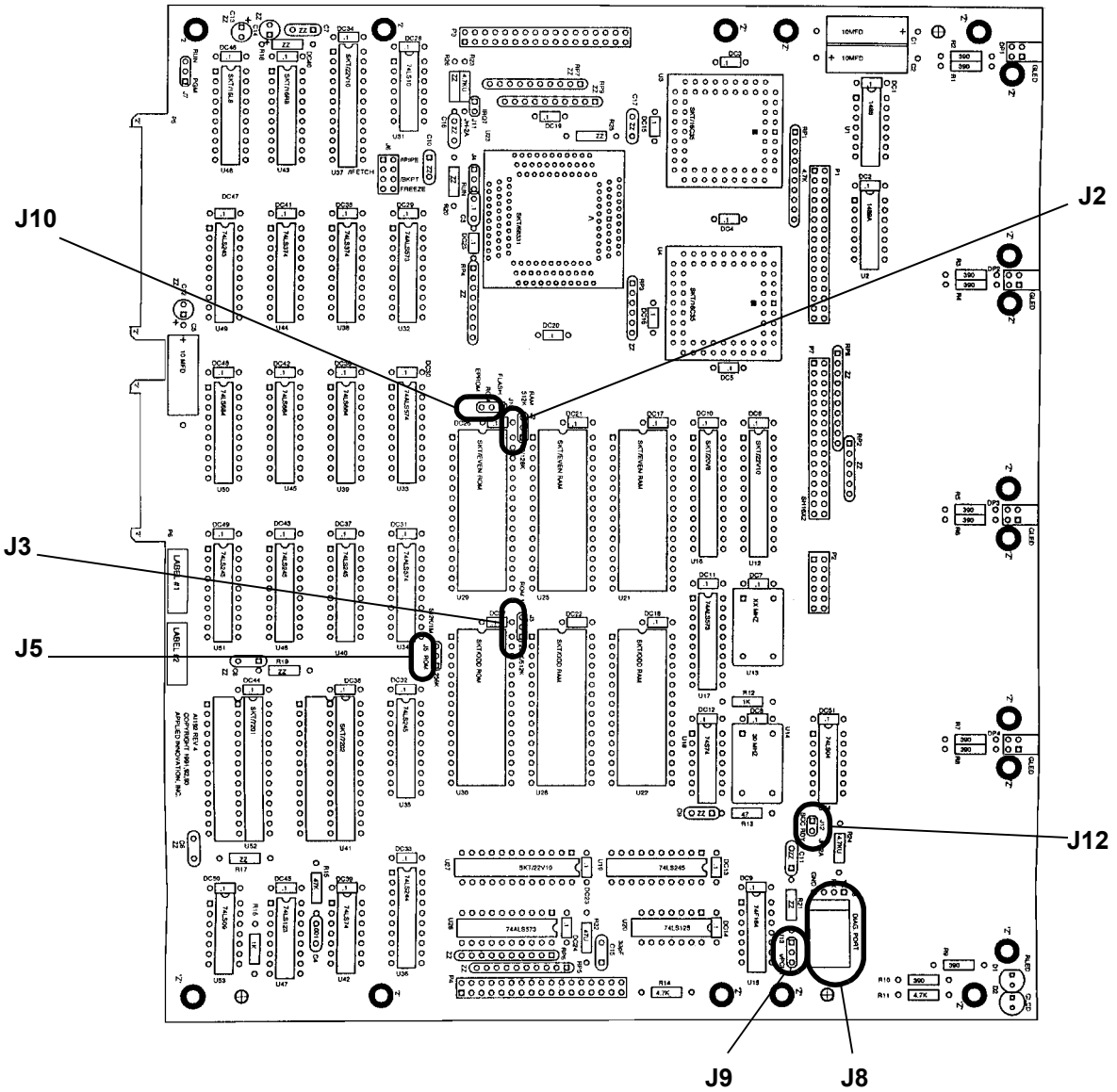

## AI192 Revision 5 Jumper Settings

[Table 7-2](#) lists the AI192 Revision 5 jumper settings. Refer to these settings in the event that the default settings change by accident (e.g. the card falls on the floor and a jumper strap falls off).



**Caution:** Do not change jumpers on the motherboard. If you do, the card may not function properly.

**Table 7-2: AI192 Revision 5 Jumper Settings**

Jumpers	Setting
J2	Installed on 2-3
J8	Diagnostic port
J9	Installed on 2-3
J19	Installed on 2-3
J20	Installed on 1-2
J21	Installed on 2-3
J22	Installed on 2-3
J23	Installed on 1-2
J24	Installed on 1-2
J25	Installed on 2-3
J26	Installed on 2-3
J27	Installed on 2-3
J28	Installed on 2-3
J29	Installed on 2-3
J30	Installed on 1-2
J31	Installed on 1-2
J32	Installed on 2-3
J33	Removed
J34	Removed



AI192 Revision 5 Board Layout

Figure 7-10 displays the AI192 Revision 5 board layout.

Figure 7-10: AI192 Revision 5 Board Layout

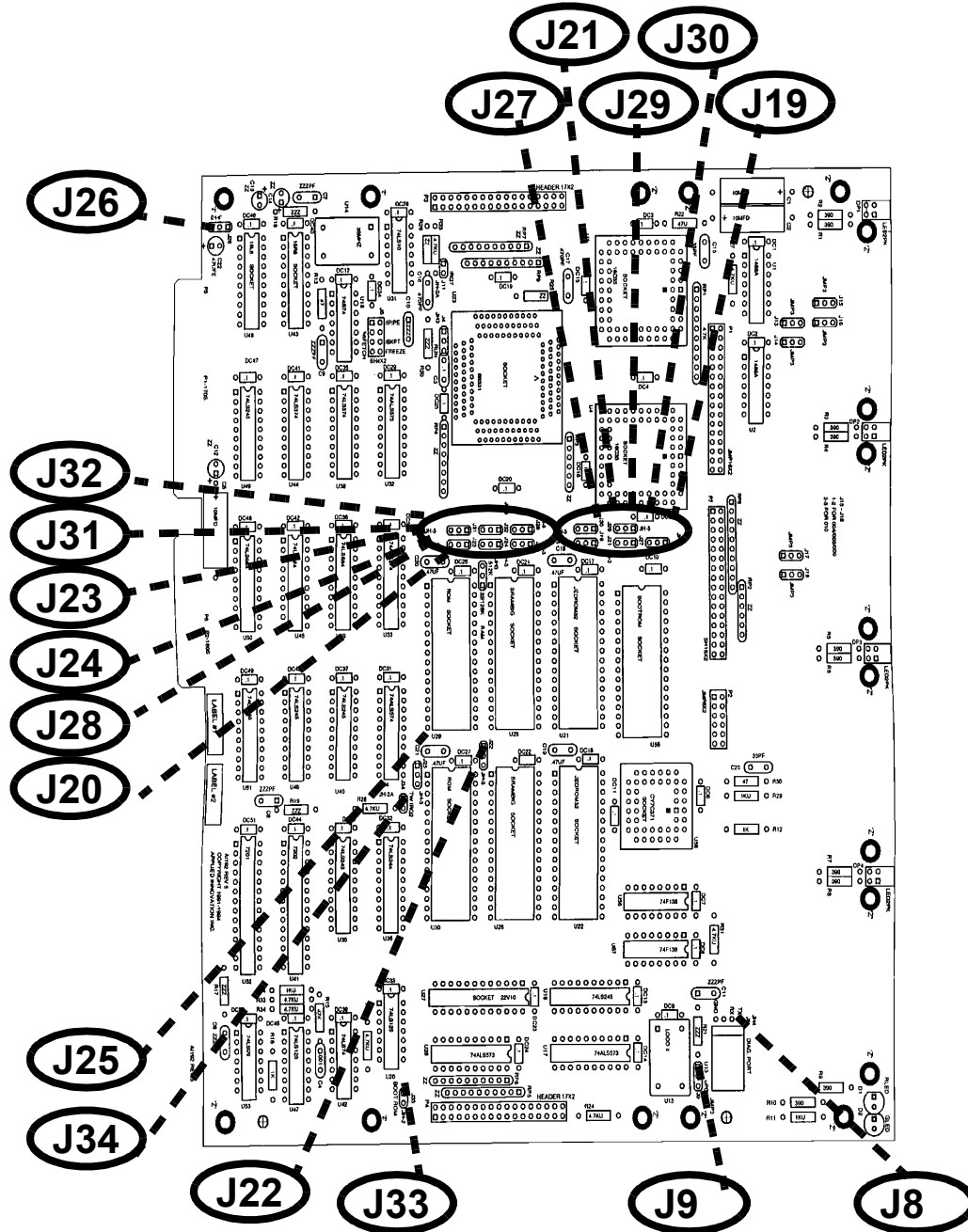

### B004 Daughterboard Jumper Settings

Each B004 RS232 daughterboard has four jumpers which must be set for internal or external clocking. The default is internal clocking. [Table 7-3](#) lists the B004 daughterboard jumper settings.

**Table 7-3: B004 Daughterboard Jumper Settings**

Jumpers	Internal Clocking (default)	External Clocking
J0, J1, J2, J3	Installed on 5-6 Installed on 7-8 Installed on 9-10	Installed on 1-2 Installed on 3-4

### B004 Daughterboard Layout

[Figure 7-11](#) displays the B004 daughterboard layout.

**Figure 7-11: B004 Daughterboard Layout**

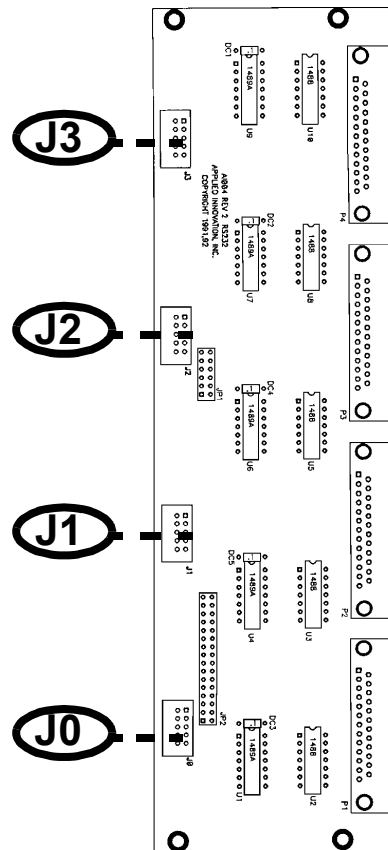

## B005 Daughterboard Jumper Settings

Each B005 V.35 daughterboard has one jumper which must be set for internal or external clocking. The default is external clocking. [Table 7-4](#) lists the B005 daughterboard jumper settings.

**Table 7-4: B005 Daughterboard Jumper Settings**

Jumper	Internal Clocking	External Clocking (default)
J2	Installed on 3-4 Installed on 7-8 Installed on 11-12 Installed on 15-16 Installed on 19-20 Installed on 23-24	Installed on 1-2 Installed on 5-6 Installed on 9-10 Installed on 13-14 Installed on 17-18 Installed on 21-22

## B005 Daughterboard Layout

[Figure 7-12](#) displays the B005 daughterboard layout.

**Figure 7-12: B005 Daughterboard Layout**

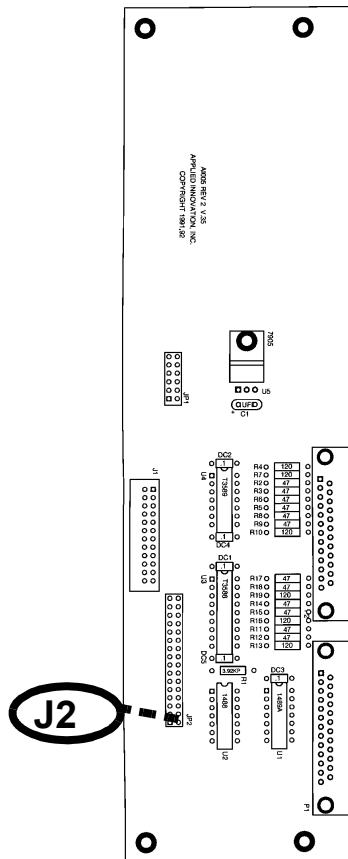

### B009 Daughterboard Jumper Settings

Each B009 RS530 daughterboard has four jumpers which must be set for internal or external clocking. The default is internal clocking. [Table 7-5](#) lists the B009 daughterboard jumper settings.

**Table 7-5: B009 Daughterboard Jumper Settings**

Jumpers	Internal Clocking (default)	External Clocking
JP3, JP4, JP5, JP6	Installed on 13-14 Installed on 15-16 Installed on 17-18 Installed on 19-20 Installed on 21-22	Installed on 1-2 Installed on 3-4 Installed on 5-6 Installed on 7-8 Installed on 9-10 Installed on 11-12

### B009 Daughterboard Layout

[Figure 7-13](#) displays the B009 daughterboard layout.

**Figure 7-13: B009 Daughterboard Layout**

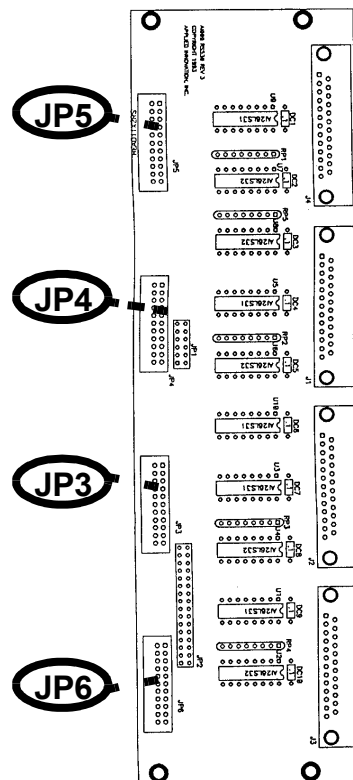

### B010 Daughterboard Jumper Settings

Each B010 T1 daughterboard has eight jumpers which must be set for master or slave. The default is slave. [Table 7-6](#) lists the B010 daughterboard jumper settings.

**Table 7-6: B010 Daughterboard Jumper Settings**

Jumper	Setting	Description
J1	Removed	Link #1 Master
J2	Installed	Link #1 Slave
J3	Removed	Link #1 Master
J8	Removed	DCD for Link #2
J4	Removed	Link #2 Master
J5	Installed	Link #2 Slave
J6	Removed	Link #2 Master
J7	Removed	DCD for Link #1

### B010 Daughterboard Layout

[Figure 7-14](#) displays the B010 daughterboard layout.

**Figure 7-14: B010 Daughterboard Layout**

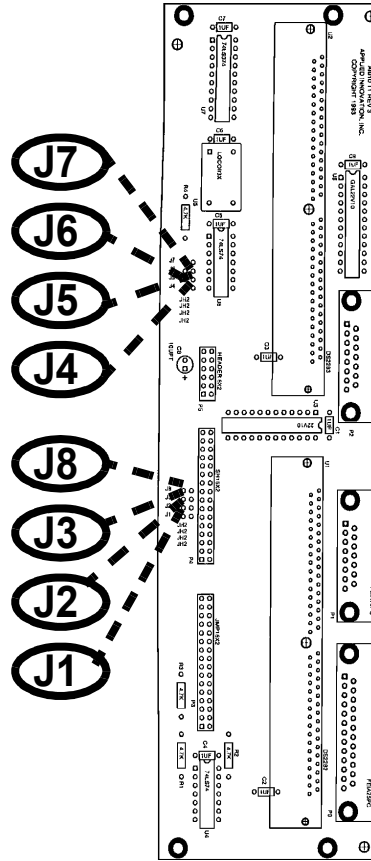

## AI193-ES

This section describes the hardware and firmware required for the AI193-ES.

**Figure 7-15: AI193-ES Faceplate**

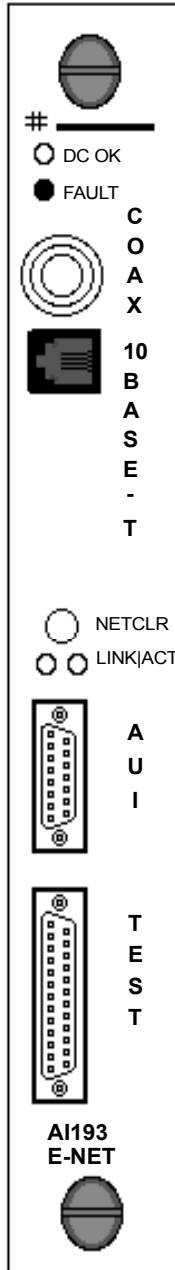

**Note:** Revision 2.1 hardware settings are required for successful operation of the Version 7.03 release of the AI193-ES.

### Firmware

The AI193-ES Version 7.03 firmware configuration supports this software version and later updates through the software download. The AI193-ES firmware is compatible with versions 6.xx, 7.xx, and 8.xx of the AI180. The software download requires an AI198 or later.

### AI193-ES Faceplate and Connectors

The following describes the faceplate and connectors associated with the AI193-ES Revision 2.1.

**DC/ OK** This green LED is always on when the system is powered up and indicates 5 volts are being supplied to the processor. If the red LED is lit, a fault has been detected.

**FAULT** If the red LED is illuminated, a fault has been detected. This LED is normally dark.

**COAX** BNC Thinwire Ethernet Data Port

**10BASE-T** 10BaseT Ethernet Data Port

**NETCLR** The green LED indicates one of the following:

- An unconnected 10BaseT connection
- A connected 10BaseT or COAX connection in a “no collision” (valid) state.

**Note:** A “no collision” (valid) state occurs when you have either a 10BaseT connection with a link established (LINK is lit), or you have a COAX or AUI connection with the proper terminations.

If this LED is dark, it indicates one of the following:

- An unconnected COAX connection
- A connected 10BaseT or COAX connection with a collision

LINK	The green LED indicates a valid 10BaseT link. If the LED is dark, it indicates an invalid 10BaseT link.
	<b>Note:</b> The green LED is always illuminated if the AI193-ES is configured to operate with a COAX or AUI connection.
ACT	The green LED indicates activity is detected on the COAX or 10BaseT connection.
AUI	Ethernet AUI interface, 15-pin D-sub female
TEST	RS-232 Diagnostic Port, 25-pin D-sub female, Data Terminal Equipment (DTE), 9600 baud, no parity, 8 data bits, 1 stop bit

The AI193-ES uses a male DB25 async null cable for the diagnostic port.

### AI193-ES Jumper Settings

The AI193-ES provides for most of its configuration in its software. The jumpers are normally corrected on receipt of the card. To confirm that the jumpers are correctly placed or to locate the jumper, refer to the AI193-ES card layout drawing in [Figure 7-16](#).



**Caution:** Do not change the jumper settings on the AI193-ES motherboard.

[Table 7-7](#) lists the jumper settings for the AI193-ES Revision 2.1.

**Table 7-7: AI193-ES Jumper Settings**

Jumper	Setting
J1	1-2
J2	2-3
J3	2-3
J4	1-2
J5	1-2
J6	1-2
J7	Not Installed
J8	1-2
J10	Open



<b>Jumper</b>	<b>Setting</b>
J11	2-3
J12	Open
J16	Closed
J18	1-2
J19	2-3
J20	2-3
J21	2-3
J22	2-3

[Table 7-8](#) lists the external connectors available for the AI193-ES and the jumper setting to use for each of the specified connectors. Only one connector is active at a time.

Bold-faced type indicates the default setting.

**Table 7-8: Ethernet Configuration Connector Jumper Settings**

<b>Selected Connector</b>	<b>AUI/TP J18</b>	<b>LINKDIS J18</b>	<b>LOWSQL J18</b>	<b>THINWIRE J16</b>
10BaseT	CLOSED	OPEN	CLOSED	OPEN
AUI	OPEN	OPEN	CLOSED	OPEN
<b>COAX</b>	<b>OPEN</b>	<b>OPEN</b>	<b>CLOSED</b>	<b>CLOSED</b>

**Note:** Refer to the SONIC section in the WINS LC Commands chapter of the *AI193-ES User's Manual* for more information on specifying you want to use the external (that is, AI193-ES faceplate connectors) connectors for connectivity.

### AI193-ES Connectors

There are four port connectors on the AI193-ES. In Version 7.02 of the software, P2 is used for the diagnostic port while P4, P6, and P7 are not used. In Version 7.03, P2, P4, P6, and P7 all have assigned functionality. Refer to [Table 7-9](#) for more information.

**Note:** Any pins not listed in the following tables are not connected.

**Table 7-9: AI193-ES Version 7.03 Connector Descriptions**

Connector	Label	Description
P7	COAX	BNC Thinwire Ethernet Data Port
		Pin: Inner COAX and Outer COAX Function: Inner COAX - Signal Outer COAX - Shield
P6	10BaseT	10BaseT Ethernet Data Port
		Pin: 1 Function: +TD (Transmit Data)
		Pin: 2 Function: -TD (Transmit Data)
		Pin: 3 Function: +RD (Receive Data)
P4	AUI	Pin: 6 Function: -RD (Receive Data)
		Ethernet AUI interface, 15-pin D-sub female
		Pin: 1 Function: Frame ground or signal ground is accessed via J9 jumper. Frame ground is the default. (J9 set to 1-2.)
		Pin: 2 Function: +CD (Carrier Detect)
		Pin: 3 Function: +TX (Transmit Data)
		Pin: 4 Function: Frame ground or signal ground is accessed via J9 jumper. Frame ground is the default. (J9 set to 1-2.)

Connector (Continued)	Label	Description
P4 (Cont.)	AUI (Cont.)	Pin: 5 Function: +RX (Receive Data)
		Pin: 6 Function: Signal ground
		Pin: 8 Function: Frame ground or signal ground is accessed via J9 jumper. Frame ground is the default. (J9 set to 1-2.)
		Pin: 9 Function: -CD (Carrier Detect)
		Pin: 10 Function: -TX (Transmit Data)
		Pin: 11 Function: Frame ground or signal ground is accessed via J9 jumper. Frame ground is the default. (J9 set to 1-2.)
		Pin: 12 Function: -RX (Receive Data)
		Pin: 13 Function: +12V
		Pin: 14 Function: Frame ground or signal ground is accessed via J9 jumper. Frame ground is the default. (J9 set to 1-2.)
P2	TEST	RS-232 Diagnostic port, 25-pin D-sub female, DTE, 9600 baud, no parity, 8 data bits, 1 stop bit
		Pin: 1 Function: Frame ground
		Pin: 2 Function: TX (Transmit Data)
		Pin: 3 Function: RX (Receive Data)
		Pin: 7 Function: Signal ground
		Pin: 20 Function: Data Terminal Ready (DTR)

### AI193-ES Revision 2.1 Card Layout

Figure 7-16 displays the jumpers for the AI193-ES Revision 2.1.

Figure 7-16: AI193-ES Revision 2.1 Card Layout

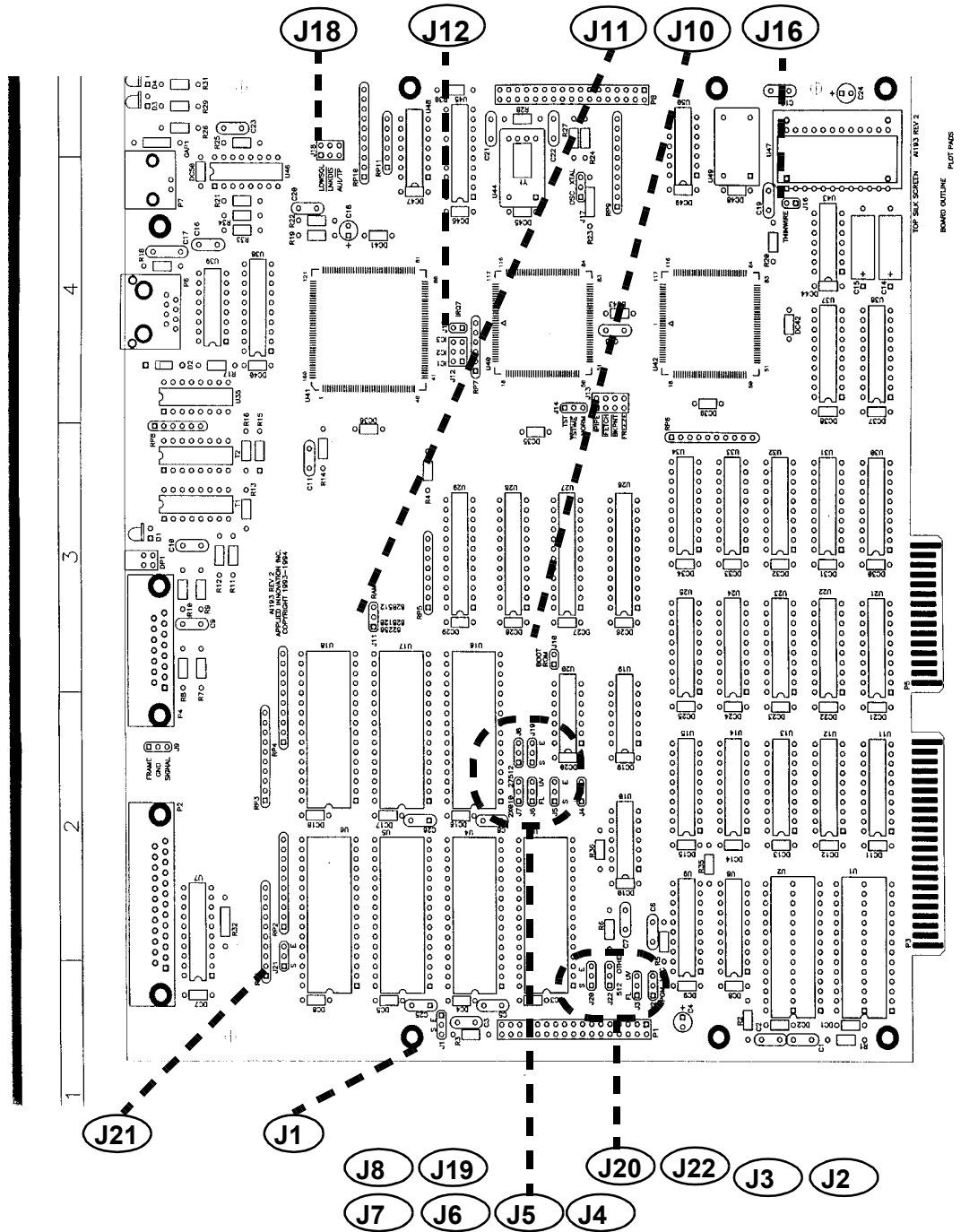

## AI193-FT

This section describes the hardware associated with the AI193-FT.

### AI193-FT Faceplate

**Figure 7-17:**  
AI193-FT Faceplate

The following describes the faceplate and connectors associated with the AI193-FT Revision A:

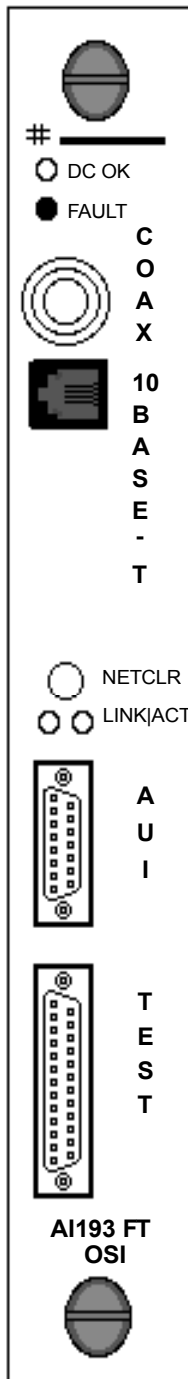

DC/ OK	This green LED is always on when the system is powered up and indicates 5 volts are being supplied to the processor. If the red LED is lit, a fault has been detected.
FAULT	If the red LED is illuminated, a fault has been detected. This LED is normally dark.
COAX	BNC Thinwire Ethernet Data Port
10BASE-T	10BaseT Ethernet Data Port
NETCLR	The green LED indicates one of the following: <ul style="list-style-type: none"> <li>● An unconnected 10BaseT connection</li> <li>● A connected 10BaseT or COAX connection in a “no collision” (valid) state</li> </ul> <p><b>Note:</b> A “no collision” (valid) state occurs when you have either a 10BaseT connection with a link established (LINK is lit), or you have a COAX or AUI connection with the proper terminations.</p> <p>If this LED is dark, it indicates one of the following:</p> <ul style="list-style-type: none"> <li>● An unconnected COAX connection</li> <li>● A connected 10BaseT or COAX connection with a collision</li> </ul>
LINK	The green LED indicates a valid 10BaseT link. If the LED is dark, it indicates an invalid 10BaseT link. <p><b>Note:</b> The green LED is always illuminated if the AI193-FT is configured to operate with a COAX or AUI connection.</p>
ACT	The green LED indicates activity is detected on the COAX or 10BaseT connection.
AUI	Ethernet AUI interface, 15-pin D-sub female
TEST	RS-232 Diagnostic Port, 25-pin D-sub female, Data Terminal Equipment (DTE), 9600 baud, no parity, eight data bits, one stop bit

The AI193-FT uses a male DB25 Async Null cable for the diagnostic port.

### AI193-FT Jumper Settings

The AI193-FT provides for most of its configuration in its software. The jumpers are normally corrected on receipt of the card. To confirm that the jumpers are correctly placed or to locate a jumper, refer to the AI193-FT card layout drawing in [Figure 7-18](#).



**Caution:** Do not change jumpers on the motherboard. If you do, the AI193-FT may not function properly.

[Table 7-10](#) below shows the jumper settings for the AI193-FT Revision A.

**Table 7-10: Jumper Settings**

Jumper	Setting
J1	Installed on 1-2
J2	Removed
J3	Installed on 2-3
J4	Installed on 2-3
J5	Installed on 2-3
J6	Installed on 1-2
J7	Installed on 2-3
J8	Installed on 2-3
J10	Removed
J11	Installed on 2-3
J12	Removed
J16	Installed
J19	Installed on 2-3
J20	Installed on 2-3
J21	Installed on 2-3
J22	Installed on 2-3

[Table 7-11](#) shows the external connectors available for the AI193-FT and the jumper setting to use for each of the specified connectors. Only one connector is active at a time.

Bold-faced type indicates the default setting.

**Table 7-11: Ethernet Configuration Connector Jumper Settings**

<b>Selected Connector</b>	<b>AUI/TP J18</b>	<b>LINKDIS J18</b>	<b>LOWSQL J18</b>	<b>THINWIRE J16</b>
10BaseT	Installed	Removed	Installed	Removed
AUI	Removed	Removed	Installed	Removed
<b>COAX</b>	<b>Removed</b>	<b>Removed</b>	<b>Installed</b>	<b>Installed</b>

### AI193-FT Connectors

All four port connectors on the AI193-FT (P2, P4, P6, and P7) have assigned functionality. Refer to [Table 7-12](#) below.

**Note:** Any pins not listed in the following table are not connected.

**Table 7-12: Version 8.00 Connector Descriptions**

<b>Connector</b>	<b>Label</b>	<b>Description</b>
P7	COAX	BNC Thinwire Ethernet Data Port
		Pin: Inner COAX and Outer COAX Function: Inner COAX - Signal Outer COAX - Shield
P6	10BASE-T	10BaseT Ethernet Data Port
		Pin: 1 Function: +TD (Transmit Data)
		Pin: 2 Function: -TD (Transmit Data)
		Pin: 3 Function: +RD (Receive Data)
		Pin: 6 Function: -RD (Receive Data)

Connector (Continue)	Label	Description
P4	AUI	Ethernet AUI interface, 15-pin D-sub female
		Pin: 1 Function: Frame ground or signal ground is accessed via J9 jumper. Frame ground is the default. (J9 is installed on 1-2.)
		Pin: 2 Function: +CD (Carrier Detect)
		Pin: 3 Function: +TX (Transmit Data)
		Pin: 4 Function: Frame ground or signal ground is accessed via J9 jumper. Frame ground is the default. (J9 is installed on 1-2.)
		Pin: 5 Function: +RX (Receive Data)
		Pin: 6 Function: Signal ground
		Pin: 8 Function: Frame ground or signal ground is accessed via J9 jumper. Frame ground is the default. (J9 is installed on 1-2.)
		Pin: 9 Function: -CD (Carrier Detect)
		Pin: 10 Function: -TX (Transmit Data)
		Pin: 11 Function: Frame ground or signal ground is accessed via J9 jumper. Frame ground is the default. (J9 is installed on 1-2.)
		Pin: 12 Function: -RX (Receive Data)
		Pin: 13 Function: +12V
		Pin: 14 Function: Frame ground or signal ground is accessed via J9 jumper. Frame ground is the default. (J9 is installed on 1-2.)



Connector (Continue)	Label	Description
P5	TEST	RS-232 Diagnostic port, 25-pin D-sub female, DTE, 9600 baud, no parity, eight data bits, one stop bit
		Pin: 1 Function: Frame ground
		Pin: 2 Function: TX (Transmit Data)
		Pin: 3 Function: RX (Receive Data)
		Pin: 7 Function: Signal ground
		Pin: 20 Function: Data Terminal Ready (DTR)

### AI193-FT Revision A Card Layout

Figure 7-18 below illustrates the jumpers for the AI193-FT Revision A.

Figure 7-18: AI193-FT Revision A Card Layout

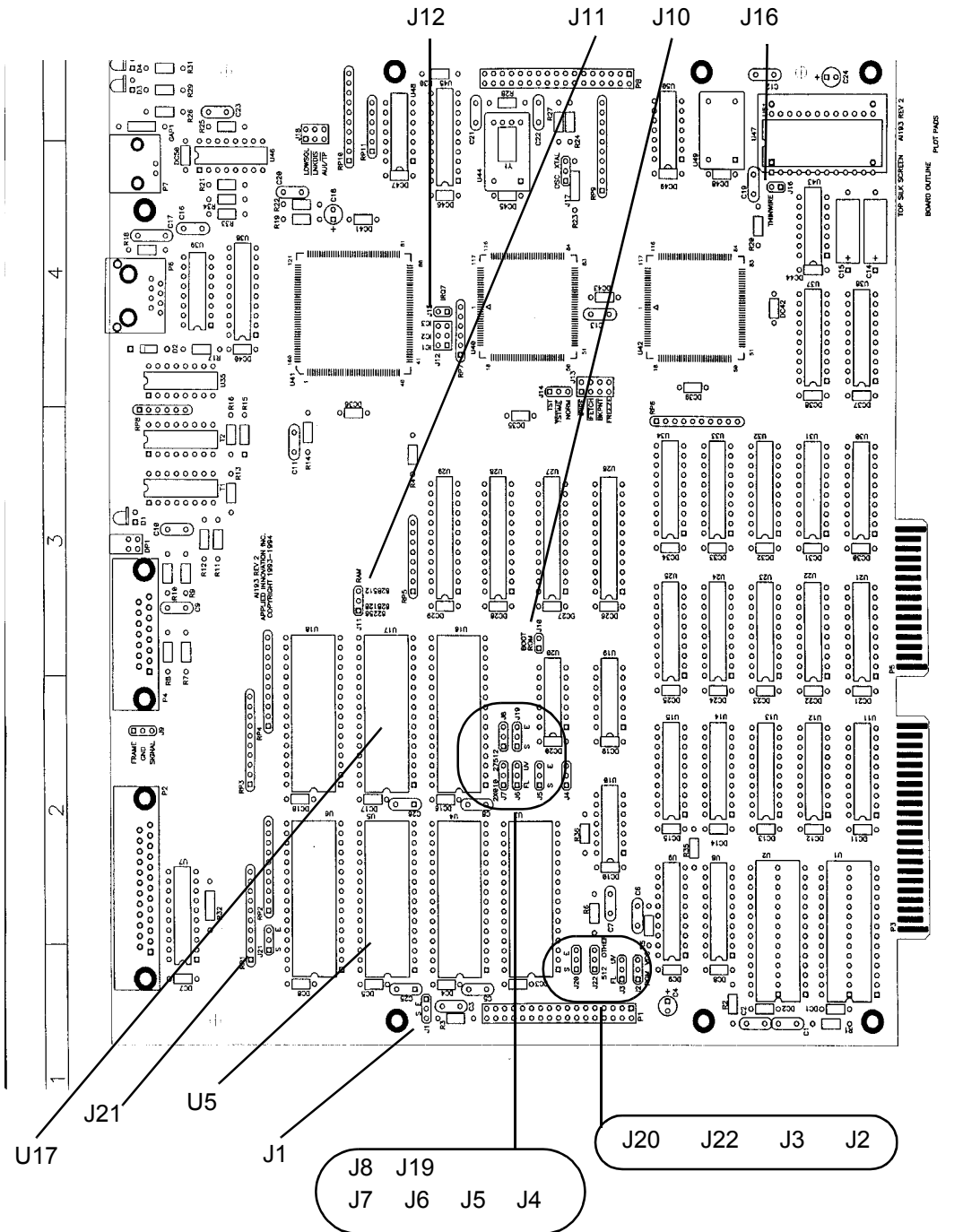

## AI193-TX

This section describes the hardware associated with the AI193-TX Version 7.06 software.

### AI193-TX Faceplate and Connectors

This following describes the faceplate and connectors associated with the AI193-TX.

**Figure 7-19: AI193-TX Faceplate**

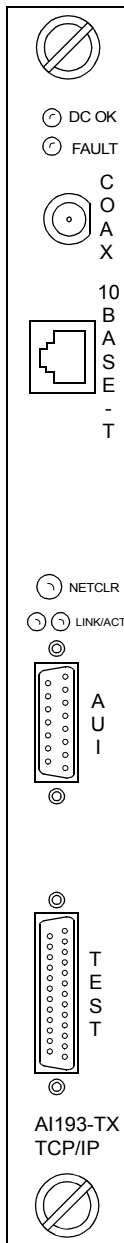

DC/OK	This green LED is always on when the system is powered up and indicates 5 volts are being supplied to the processor. If the red LED is lit, a fault has been detected.
FAULT	If the red LED is illuminated, a fault has been detected. This LED is normally dark.
COAX	BNC Thinwire Ethernet Data Port
10BASE T	10BaseT Ethernet Data Port
NETCLR	The green LED indicates a “no collision” state on a valid COAX or 10BaseT connection. It is dark if there is no valid connection, or if a collision is detected.
LINK	The green LED shows a valid 10BaseT link.
ACT	The green LED indicates activity is detected on the COAX or 10BaseT connection.
AUI	Ethernet AUI interface, 15-pin D-sub female
TEST	RS-232 Diagnostic port, 25-pin D-sub female, DTE, 9600 Baud

### AI193-TX Jumper Settings

[Table 7-13](#) lists the default jumper settings for the AI193-TX Revision 2.

**Table 7-13: AI193-TX Jumper Settings**

Jumper	Setting
J1	1-2
J2	2-3
J3	2-3
J4	2-3
J5	2-3
J6	1-2
J7	1-2*
J8	2-3
J10	OPEN
J11	2-3
J12	OPEN
J16	1-2
J18	1-2
J19	2-3
J20	2-3
J21	2-3
J22	2-3

\* no effect on operation

Verify that the C5 and C8 capacitors have been removed.

**AI193-TX Connectors**

There are four connectors on the AI193-TX. One is used for the diagnostic port while the other three are for the user’s equipment connections. The AI193-TX card layout and faceplate drawings show the location of each connector. [Table 7-14](#) lists the AI193-TX connectors and provides a description of each.

**Table 7-14: AI193-TX Connector Descriptions**

Connector	Label	Description
P7	COAX	BNC Thinwire Ethernet Data Port
		Pin: Inner Coax and Outer Coax Function: Inner Coax - Signal Outer Coax - Isolated ENET Shield
P6	10BaseT	10BaseT Ethernet Data Port
		Pin: 1 Function: +TD (Transfer Data)
		Pin: 2 Function: -TD (Transfer Data)
		Pin: 3 Function: +RD (Receive Data)
		Pin: 6 Function: -RD (Receive Data)

Connector	Label	Description
P4	AUI	Ethernet AUI interface, 15-pin D-sub female
		Pin: 1 Function: Frame ground or signal ground accessed via J9 jumper. Frame ground is the default.
		Pin: 2 Function: +CD (Carrier Detect)
		Pin: 3 Function: +TX (Transfer Data)
		Pin: 4 Function: Frame ground or signal ground accessed via J9 jumper. Frame ground is the default.
		Pin: 5 Function: +RX (Receive Data)
		Pin: 6 Function: Signal ground
		Pin: 7 Function: Not connected
		Pin: 8 Function: Frame ground or signal ground accessed via J9 jumper. Frame ground is the default.
		Pin: 9 Function: -CD (Carrier Detect)
		Pin: 10 Function: -TX (Transfer Data)
		Pin: 11 Function: Frame ground or signal ground accessed via J9 jumper. Frame ground is the default.
		Pin: 12 Function: -RX (Receive Data)
		Pin: 13 Function: +12V
		Pin: 14 Function: Frame ground or signal ground accessed via J9 jumper. Frame ground is the default.
Pin: 15 Function: Not connected		

Connector	Label	Description
P2	TEST	RS-232 Diagnostic port, 25-pin D-sub female, DTE, 9600 Baud
		Pin: 1 Function: Frame ground
		Pin: 2 Function: TX (Transfer Data)
		Pin: 3 Function: RX (Receive Data)
		Pin: 4 Function: Request To Send (RTS)
		Pin: 6 Function: Data Set Ready (DSR)
		Pin: 7 Function: Signal ground
		Pin: 20 Function: Data Terminal Ready (DTR)

[Table 7-15](#) describes the external connectors available for the AI193-TX and the jumper setting to use for the specified connector. Only one connector is active at a time.

**Table 7-15: Ethernet Configuration Connector Jumper Settings**

Selected Connector	AUI/TP J18	LINKDIS J18	LOWSQL J18	THINWIRE J16
10BaseT	CLOSED	OPEN	CLOSED	OPEN
AUI	OPEN	OPEN	CLOSED	OPEN
COAX (default)	OPEN	OPEN	CLOSED	CLOSED

[Table 7-16](#) displays the jumper strap position to set the speed of the internal oscillator.



**Caution:** These straps should not be changed. They are preset at the factory.

**Table 7-16: Clock Speed Configuration Jumper Settings.**

Jumper Setting	IC3 J12	IC2 J12	IC1 J12	Speed Mhz
default	OPEN	OPEN	OPEN	13.631
Unused	OPEN	OPEN	CLOSED	15.729
Unused	OPEN	CLOSED	OPEN	16.515
Unused	OPEN	CLOSED	CLOSED	8
Unused	CLOSED	OPEN	OPEN	8
Unused	CLOSED	OPEN	CLOSED	8
Unused	CLOSED	CLOSED	OPEN	8
Unused	CLOSED	CLOSED	CLOSED	8





## AI194

This section describes the hardware and firmware required for the Version 7.04 release of the AI194.

**Note:** You must return your AI194 to AI if you want to upgrade to Version 7.04 or later software. Contact your sales representative for more information.

**Note:** You must use Version 1.20 or later of the AI198 software if you want to use the Auto-ID (board/inventory identification) functionality.

### IRB Enable/Disable

The AI194 allows you to manually or automatically control enabling or disabling the IRB. Refer to the following sections.

#### *Manual Control*

Jumper J7 has three settings to control the AI194 interface to the IRB. If Jumper J7 is in the OPEN position, the IRB is unconditionally enabled. For direct replacement of older hardware, use the OPEN position. If the Jumper J7 is in the 1-2 position, the IRB is hardware disabled. This position should be used when you desire to isolate the AI194 from other boards in the system. If Jumper J7 is in the 2-3 position, the IRB is disabled and is under software control. You must then enter either the **irb enable** or **irb disable** command via the craft, log, or any async port to turn the IRB interface on.

#### *Automatic Control*

To have automatic control of the IRB enable/disable function, you must enter the **irb enable** or **irb disable** command via the craft, log, or any async port. Refer to the winslc Commands chapter of the *AI194 User's Manual* for more information.

### AI194 Faceplate and Connectors

The following is a description of the faceplate and connectors associated with the AI194.

**Figure 7-21: AI194 Faceplate**

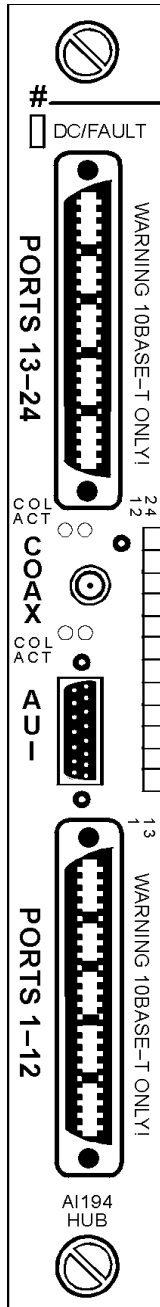

- DC/FAULT**      The DC/FAULT indicator light is green when the board is up and running correctly. This indicator light is red when the processor is in a halt state.
- PORTS 13-24**    This connector is an industry standard 50-pin twisted pair Ethernet connector for ports 13 to 24.
- COL ACT**        The COL (collisions) indicator light illuminates once for each collision on the associated Ethernet link. The ACT (activity) indicator light illuminates when the link is alive. When the ACT indicator light is illuminated, data packets are being transferred on the link.
- COAX**            This connector is a Thinnet COAX Ethernet connector.
- LEDs**            There are 24 bi-color LEDs for the 24 10BaseT ports associated with the AI194. The following indicates color and status:

  - Dark = off
  - Red = receiving data
  - Green = up and connected
  - Yellow or Orange = up and receiving data
- AUI**             This connector is an industry standard 15-pin Ethernet connector.
- PORTS 1-12**    This connector is an industry standard 50-pin twisted pair Ethernet connector for ports 1 to 12.

### AI194 Jumper Settings

The AI194 provides for most of its configuration in software. The jumpers are normally configured on receipt of the card. To confirm that the jumpers are correctly placed or to change the setting, refer to the [AI194 Revision 4 Card Layout](#) illustration. [Table 7-17](#) lists the jumper settings associated with the AI194. Note that boldface text indicates default settings.

**Table 7-17: AI194 Jumper Settings**

Jumper	Setting	Description
J2	<b>installed on 1-2</b> installed on 2-3	<b>EPROM select</b> +12 V Flash *No effect on operation
J3	<b>installed on 1-2</b> installed on 2-3	<b>Select 128 KB SRAMS</b> Select 512 KB SRAMS
J4	<b>installed on 1-2</b> installed on 2-3	<b>Select SPROM</b> Select Flash
J5	<b>installed on 1-2</b> installed on 2-3	<b>Select pgmult</b> Select 5 V FLASH
J7	OPEN	IRB enabled

### AI194 Connectors

There are six connectors on the AI194. One is used for attaching the LED status daughterboard, one is for the diagnostic port, and the other four are for your equipment connections. [Table 7-18](#) lists the AI194 connectors and provides a description of each.

**Table 7-18: AI194 Connectors**

Connector	Description	Pin	Function
JP1	AI013 LED display board connector proprietary for connection to LED		
JP2	Diagnostic port connector	1	Transmits data
		2	Receives data
		3	Not connected
		4	Signals ground
P1	Twisted pair Ethernet ports 1 to 12 industry standard 50-pin connector		
P2	Ethernet AUI interface	9	CD collision pair
	15-Pin D-sub female IEEE 802.3 compatible	2	CD collision pair
		10 3 5 13 1, 11 4,14 8 6	Tx- data Tx+ data Rx- data Rx+ data +23 V Signal ground
P3	Thinnet COAX Ethernet connector		
P4	Twisted pair Ethernet ports 13 to 24 industry standard 50-pin connector		

### AI194 Revision 4 Card Layout

Figure 7-22 displays the AI194 Revision 4 card layout.

Figure 7-22: AI194 Revision 4 Card Layout

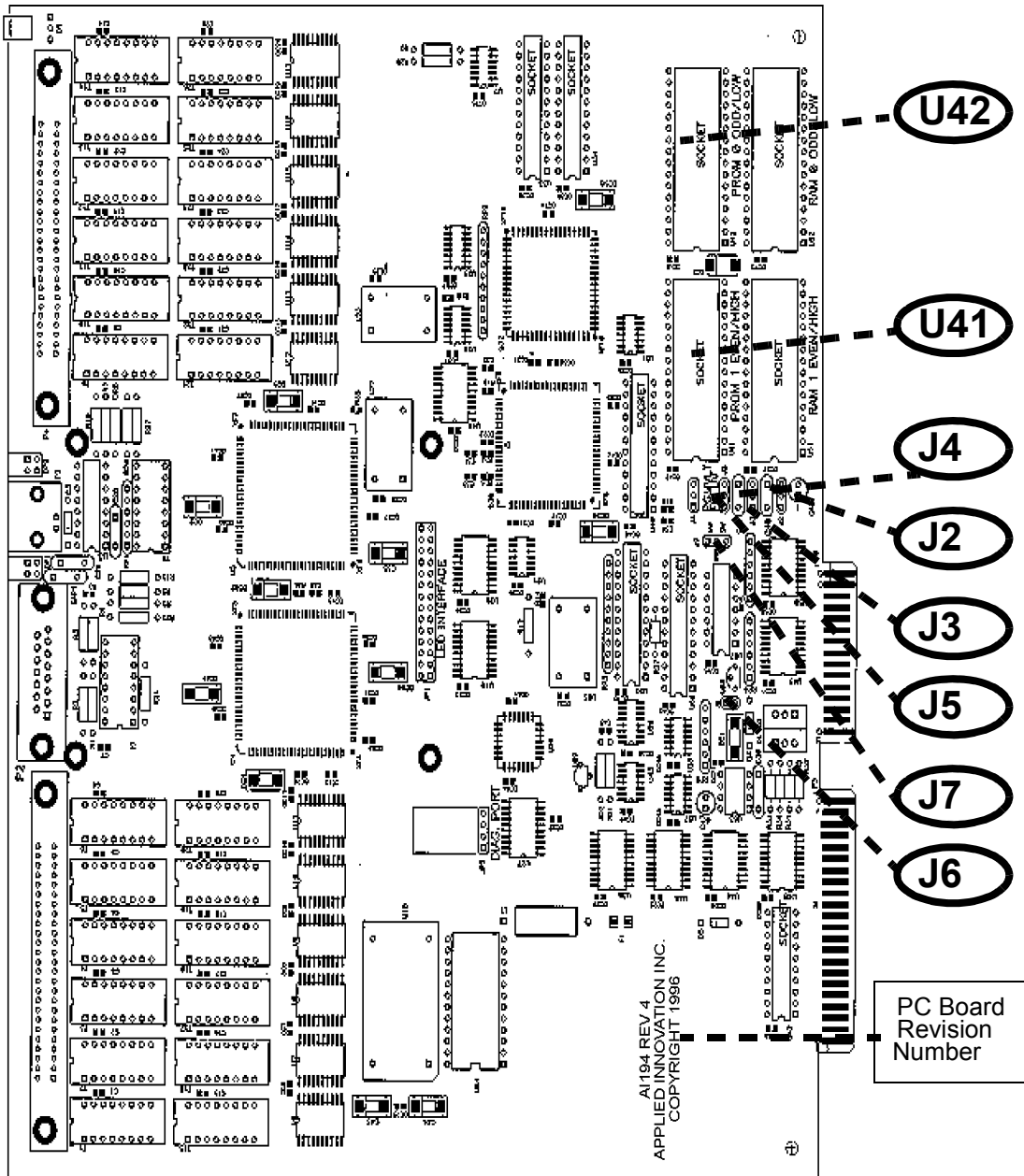

## AI196-ETS

This section contains information about hardware requirements, jumper settings, motherboard diagram, and daughterboard layouts for the AI196-ETS Revision 5.



**Caution:** The AISwitch and its peripherals contain electrostatic sensitive components. Exercise proper handling, shipping, and storage precautions.

**Figure 7-23: AI196-ETS Faceplate**

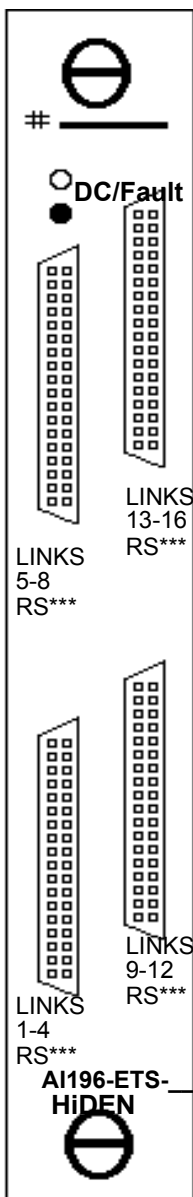

### AI196-ETS Faceplate and Connectors

The following is a description of the faceplate and connectors associated with the AI196-ETS.

- DC/FAULT This green LED is always on when the system is powered up and indicates 5 volts are being supplied to the processor. If the red LED is lit, a fault has been detected.
- LINKS 1-4 This connector is used for links 1 through 4.
- LINKS 5-8 This connector is used for links 5 through 8.
- LINKS 9-12 This connector is used for links 9 through 12.
- LINKS 13-16 This connector is used for links 13 through 16.

### Table 7-19: AI196-ETS Faceplate Variations

[Table 7-19](#) is a listing of the AI196-ETS faceplate variations.

Faceplate	Link Types
AI196-ETS-RG	All RS-232
AI196-ETS-EG	All RS-530
AI196-ETS-ECR4	Links 1 to 12, RS-530 Links 13 to 16, RS-232

## AI196-ETS Jumper Settings

[Table 7-20](#) shows the default jumper settings for the AI196-ETS board.

**Table 7-20: Jumper Settings**

Jumper	Setting
J1	DIAG
J2	OPEN
J3	OPEN
J4	1-2
J5	OPEN
J10	1-2
J11	1-2
J12	2-3
J13	2-3
J14	2-3
J15	2-3
J16	OPEN
J17	2-3
J18	2-3
J19	2-3
J20	1-2
J21	2-3

## Power Supply/Cooling Requirements

The number of AI196-ETS cards that can be used with the RDC180-P power supply is limited to four. If you have more than four AI196-ETS cards in a chassis, the RDC180-HP power supply is required. The number of AI196-ETS cards that can be used with the RDC180-HP power supply is unlimited.

If greater cooling capacity is required, the AI180-FRF and FRR Fan Units are recommended.



### **B014 Daughterboard**

The AI196-ETS requires one B014 daughterboard. This board is added to provide 8 MBs of memory.

No jumper settings are required for this board.

### **B016 Daughterboard Jumper Settings**

The AI196-ETS card requires four daughterboards for the link interface. Each B016 RS232 daughterboard has four pair of jumpers, one pair for each link. No jumper settings are required for this board.

### **B055 Daughterboard Jumper Settings**

For the AI196-ETS, the B055 daughterboard must have jumper 2 installed. Refer to [Figure 7-24](#).

### B055 Daughterboard Layout

[Figure 7-24](#) displays the B055 daughterboard layout.

**Figure 7-24: B055 Daughterboard Layout**

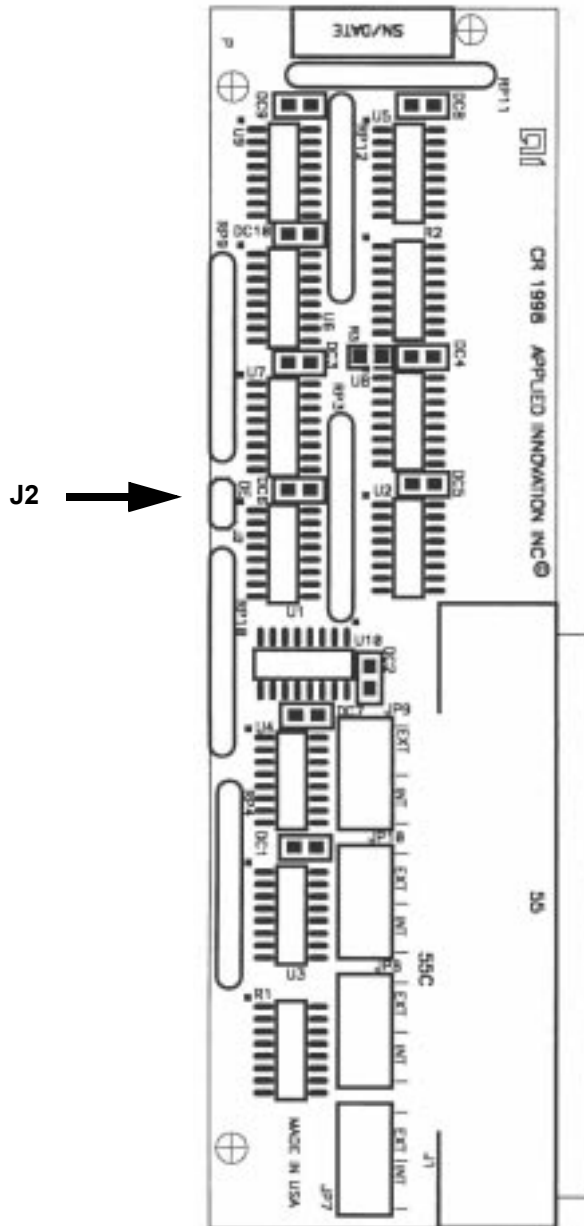

AI196-ETS Revision 5 Card Layout

Figure 7-25 displays the AI196-ETS Revision 5 card layout.

Figure 7-25: AI196-ETS Revision 5 Card Layout

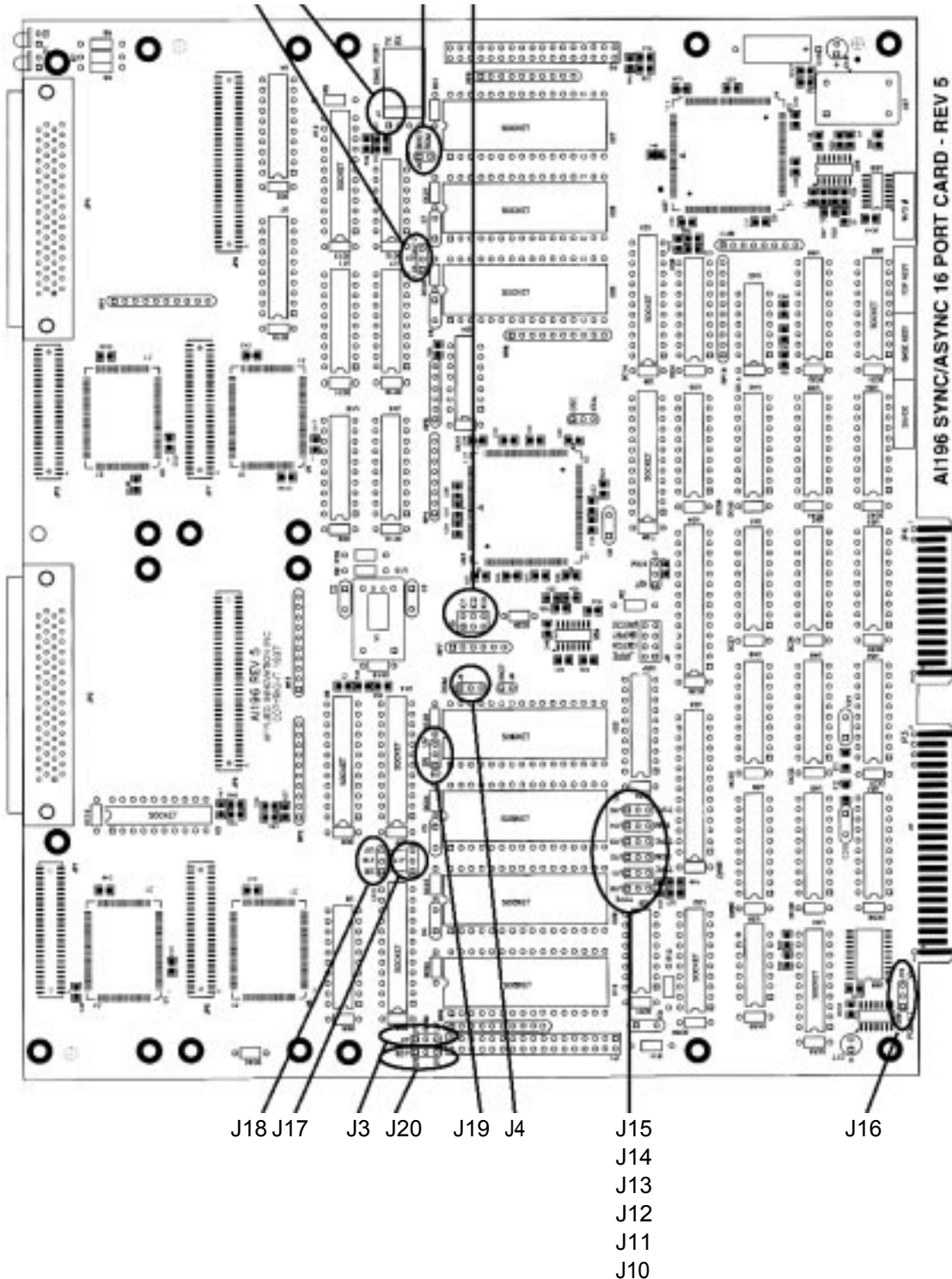

## AI196-I

This section contains information about hardware requirements, jumper settings, motherboard diagram, and daughterboard layouts for the AI196-I Revision 5.



**Caution:** The AISwitch and its peripherals contain electrostatic sensitive components. Exercise proper handling, shipping, and storage precautions.

### Requirements

#### *Central Logic Controller (CLC)*

The AI196-I requires at least one AI198.

#### *Power Supplies*

If you have more than four AI196-I cards in a chassis, you must use an RDC180-HP power supply. If you have less than four AI196-I cards, you may use an RDC180-P; however, AI recommends the RDC180-HP.

#### *Cooling*

Use the optional AICOOL-48 if you use more than four AI196-I cards.

**Figure 7-26: AI196-I AI196-I Faceplate and Connectors**

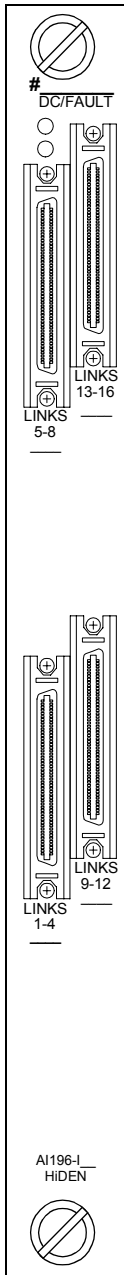

The following is a description of the faceplate and connectors associated with the AI196-I.

- DC/FAULT This green LED is always on when the system is powered up and indicates 5 V are being supplied to the processor. If the red LED is lit, a fault has been detected.
- LINKS 5-8 Use this connector for links 5 to 8.
- LINKS 13-16 Use this connector for links 13 to 16.
- LINKS 1-4 Use this connector for links 1 to 4.
- LINKS 9-12 Use this connector for links 9 to 12.

**Table 7-21: AI196-I Faceplate Variations**

[Table 7-21](#) is a description of the AI196-I faceplate variations.

Faceplates	Links 1 to 4	Links 5 to 8	Links 9 to 12	Links 13 to 16
AI196IECV4	RS-530	RS-530	RS-530	V.35
AI196IR4V8	RS-232	RS-530	V.35	V.35
AI196IR4V4	RS-232	RS-530	RS-530	V.35
AI196IR8V4	RS-232	RS-232	RS-530	V.35
AI196IRCV4	RS-232	RS-232	RS-232	V.35
AI196IEGB	RS-530	RS-530	RS-530	RS-530
AI196IEG	RS-530	RS-530	RS-530	RS-530
AI196IR4	RS-232	RS-530	RS-530	RS-530
AI196IR8	RS-232	RS-232	RS-530	RS-530
AI196IRC	RS-232	RS-232	RS-232	RS-530
AI196IRG	RS-232	RS-232	RS-232	RS-232

### AI196-I Revision 5 Jumper Settings

The following jumper settings are factory defaults for the AI196 Revision 5.



**Caution:** Do not change jumpers on the motherboard. Changing the jumpers may cause the AI196-I to function improperly.

**Table 7-22: AI196-ETS Revision 5 Jumper Settings**

Jumper	Setting
J1	Diagnostic port
J2	Removed
J3	Removed
J4	Installed on 1-2
J5	Removed
J10	Installed on 1-2
J11	Installed on 1-2
J12	Installed on 2-3
J13	Installed on 2-3
J14	Installed on 2-3
J15	Installed on 2-3
J16	Removed
J17	Installed on 2-3
J18	Installed on 2-3
J19	Installed on 2-3
J20	Installed on 1-2
J21	Installed on 2-3

**AI196-I Revision 5 Card Layout**

[Figure 7-27](#) displays the AI196-I Revision 5 card layout.

**Figure 7-27: AI196-I Revision 5 Card Layout**

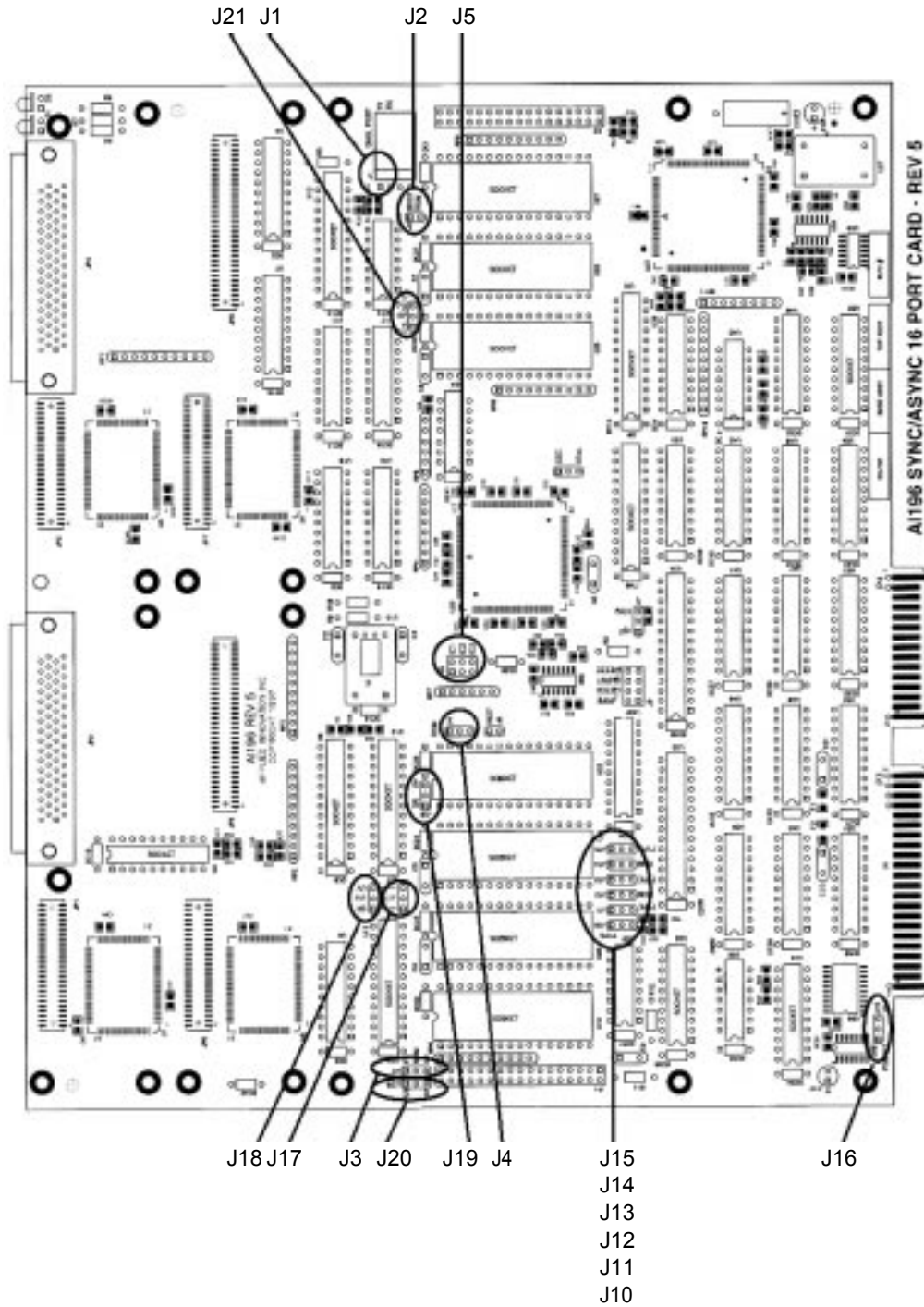

### B014 Daughterboard Layout

The AI196-I requires one B014 daughterboard. The B014 provides 8 megabytes of memory. No jumper settings are required for the B014.

### B016 Daughterboard Jumper Settings

The AI196-I requires four daughterboards for the link interface. Each B016 RS232 daughterboard has four pairs of jumpers, one pair for each link. These jumpers must be set for internal or external clocking. The default value is internal clocking. [Table 7-23](#) lists the B016 daughterboard jumper settings.

**Table 7-23: B016 Daughterboard Jumper Settings**

<b>Jumper</b>	<b>Internal Clocking (Default)</b>	<b>External Clocking</b>
JP2	Link 1 Both installed	Link Both removed
JP3	Link 2 Both installed	Link 2 Both removed
JP4	Link 3 Both installed	Link 3 Both removed
JP5	Link 4 Both installed	Link 4 Both removed



### B016 Daughterboard Layout

[Figure 7-28](#) displays the B016 daughterboard layout.

**Figure 7-28: B016 Daughterboard Layout**

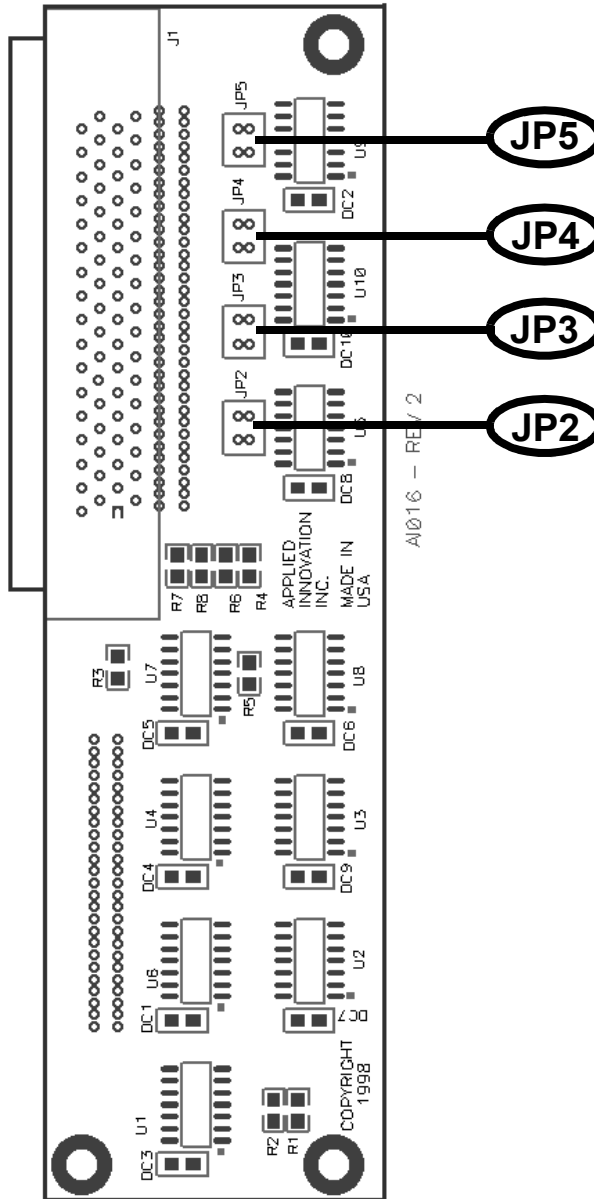

### B017 Daughterboard Jumper Settings

The AI196-I requires four daughterboards for the link interface. Each B017 EIA530 daughterboard has four sets of jumpers, one set for each link. These jumpers must be set for internal or external clocking. The default value is internal clocking. [Table 7-24](#) lists the B017 daughterboard jumper settings.

**Table 7-24: B017 Daughterboard Jumper Settings**

Jumper	Internal Clocking (Default)	External Clocking
JP9	Link 1 9 to 16 installed	Link 1 1 to 8 removed
JP10	Link 2 9 to 16 installed	Link 2 1 to 8 removed
JP8	Link 3 9 to 16 installed	Link 3 1 to 8 removed
JP7	Link 4 9 to 16 installed	Link 4 1 to 8 removed

**B017 Daughterboard Layout**

[Figure 7-29](#) displays the B017 daughterboard layout.

**Figure 7-29: B017 Daughterboard Layout**

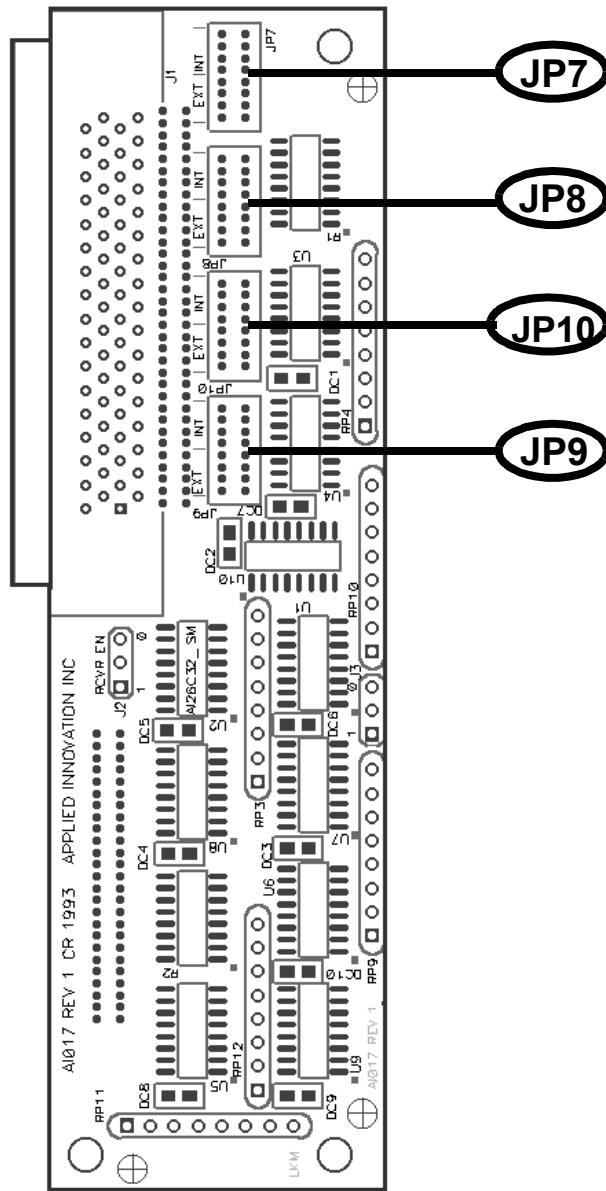

### B032 Daughterboard Jumper Settings

The AI196-I requires four daughterboards for the link interface. Each B032 V.35 daughterboard has four sets of jumpers, one set for each link. These jumpers must be set for internal or external clocking. The default value is internal clocking. [Table 7-25](#) lists the B032 daughterboard jumper settings.

**Table 7-25: B032 Daughterboard Jumper Settings**

Jumper	Port	Internal Clock (Default)	External Clock
JP3	1	All installed	All removed
JP4	2	All installed	All removed
JP5	3	All installed	All removed
JP6	4	All installed	All removed

**B032 Daughterboard Layout**

Figure 7-30 displays the B032 daughterboard layout.

**Figure 7-30: B032 Daughterboard Layout**

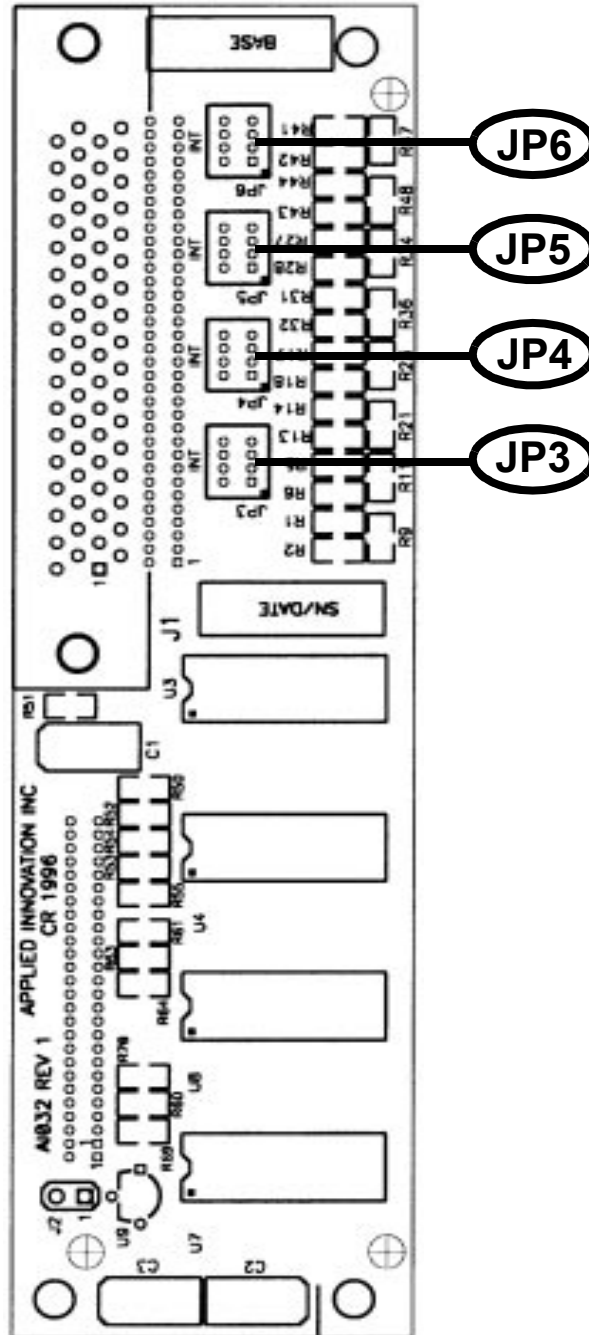

## AI196-IEGB

This section contains information about hardware requirements, jumper settings, motherboard diagram, and daughterboard layouts for the AI196-IEGB.

### Power Supply/Cooling Requirements

The number of AI196-IEGB Revision 3 cards that can be used with the RDC180-P power supply is limited to 4. If you have more than four AI196-IEGB cards in a chassis, the RDC180-HP power supply is required. The number of AI196-IEGB Revision 3 cards that can be used with the RDC180-HP power supply is unlimited.

If greater cooling capacity is required, the AICOOL-48 Fan Unit is recommended.

**AI196-IEGB Faceplate and Connectors**

**Figure 7-31: AI196-IEGB Faceplate**

The following is a description of the faceplate and connectors associated with the AI196-IEGB Revision 3.

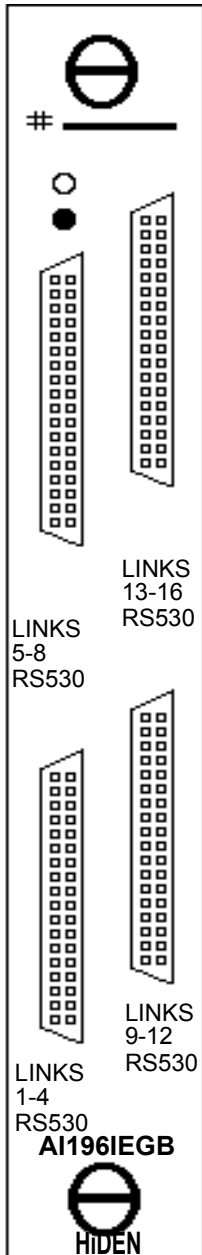

Label	Description
DC/FAULT	This green LED is always on when the system is powered up and indicates 5 volts are being supplied to the processor. If the red LED is lit, a fault has been detected.
LINKS 13-16	This connector is used for LINKS 13 through 16.
LINKS 5-8	This connector is used for LINKS 5 through 8.
LINKS 9-12	This connector is used for LINKS 9 through 12.
LINKS 1-4	This connector is used for LINKS 1 through 4.

### AI196-IEGB Jumper Settings

[Table 7-26](#) shows the default jumper settings for the AI196-IEGB Revision 3 board configuration.

**Table 7-26: AI196-IEGB Jumper Settings**

Jumper	Setting
J1	DIAG
J2	OPEN
J3	OPEN
J4	1-2
J5	OPEN
J6	OPEN
J7	OPEN
J8	OPEN
J9	OPEN
J10	1-2
J11	1-2
J12	2-3
J13	2-3
J14	2-3
J15	2-3
J16	OPEN
J17	2-3
J18	2-3
J19	2-3
J20	1-2
J21	2-3
J22	INSTALLED



### B014 Daughterboard Layout

The AI196-IEGB requires one B014 daughterboard. This daughterboard is added to provide 8 MBs of memory.

No jumper settings are required for this board.

### B017 Daughterboard Jumper Settings

The AI196-IEGB requires four daughterboards for the link interface. Each B017 EIA530 daughterboard has four sets of jumpers, one set for each link. These jumpers must be set for internal or external clocking. The default value is internal clocking. [Table 7-27](#) lists the jumper settings for the B017 daughterboard.

**Table 7-27: B017 Daughterboard Jumper Settings**

Jumper	Setting	Description
JP9	1-8	External Clocking Link 1
	<b>9-16 INSTALLED</b>	<b>Internal Clocking Link 1</b>
JP10	1-8	External Clocking Link 2
	<b>9-16 INSTALLED</b>	<b>Internal Clocking Link 2</b>
JP8	1-8	External Clocking Link 3
	<b>9-16 INSTALLED</b>	<b>Internal Clocking Link 3</b>
JP7	1-8	External Clocking Link 4
	<b>9-16 INSTALLED</b>	<b>Internal Clocking Link 4</b>

The jumper setting information only applies to the X.25 asynchronous links. It does not matter what the jumper settings are for the TTL1 links.

### B014 Daughterboard Layout

Figure 7-32 displays the B014 daughterboard layout.

Figure 7-32: B014 Daughterboard Layout

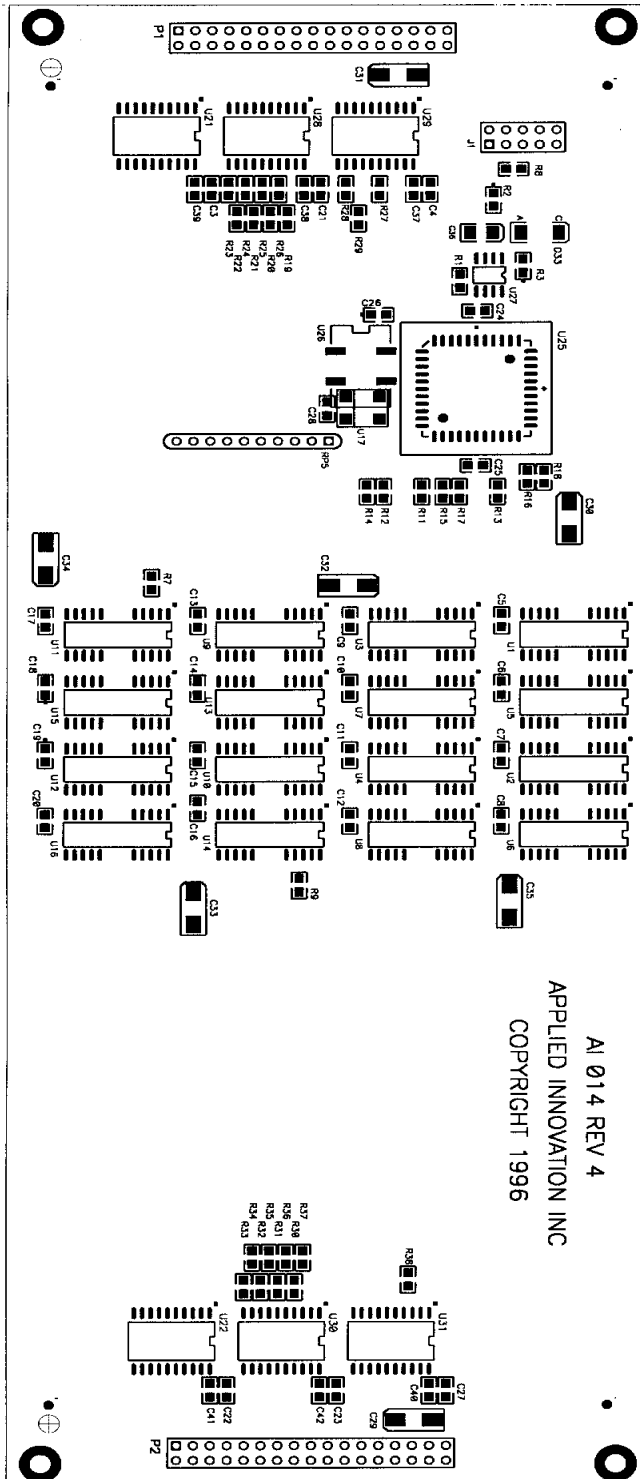

**B017 Daughterboard Layout**

[Figure 7-33](#) displays the B017 daughterboard layout.

**Figure 7-33: B017 Daughterboard Layout**

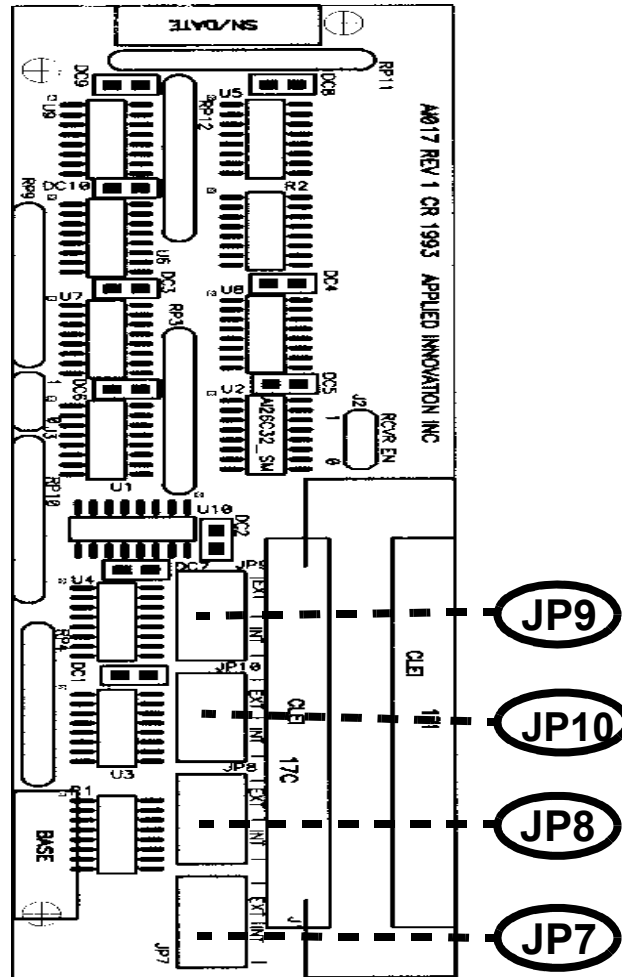

### AI196-IEGB Revision 3 Card Layout

Figure 7-34 displays the AI196-IEGB Revision 3 card layout.

Figure 7-34: AI196-IEGB Revision 3 Card Layout

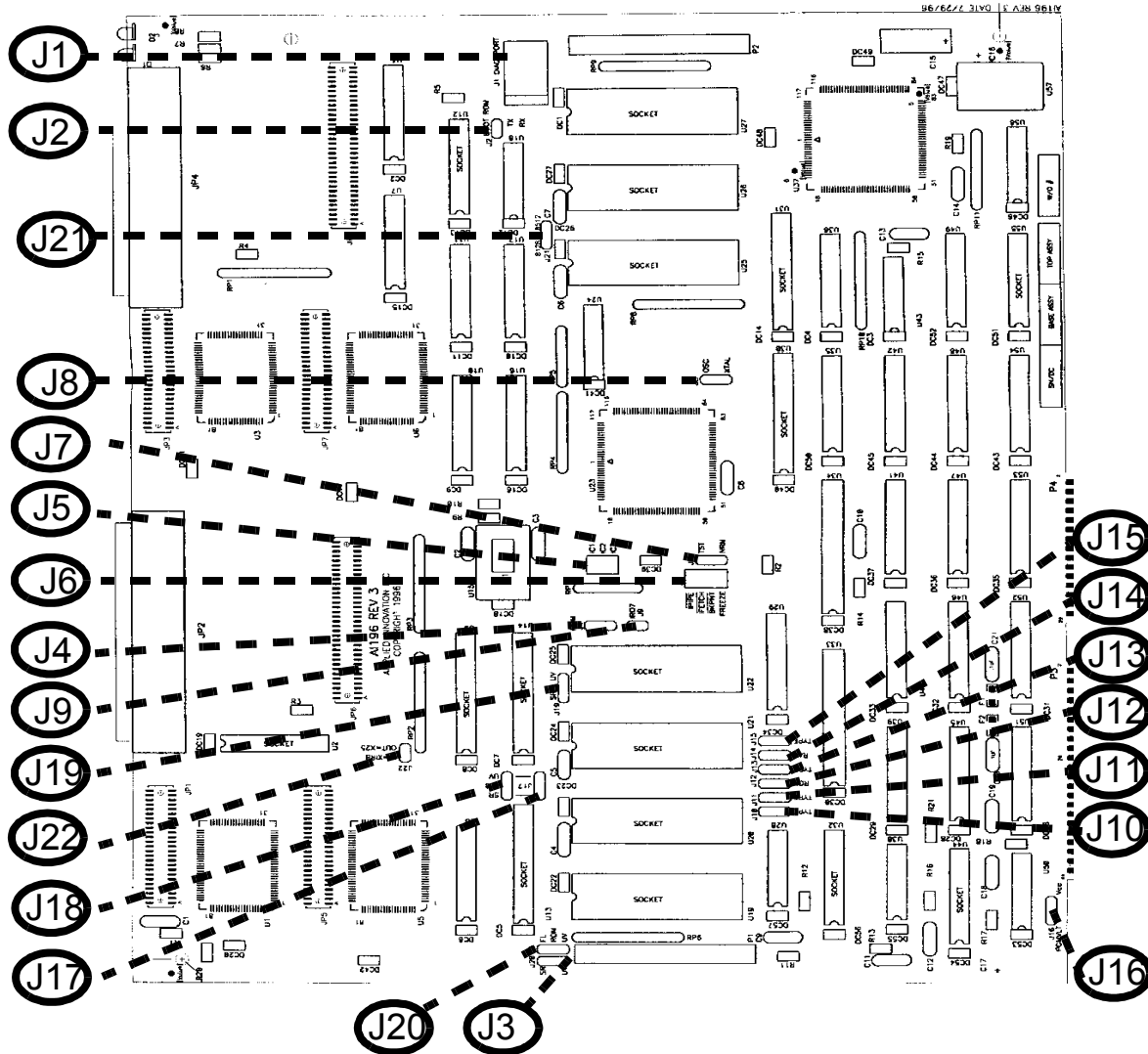

**AI196-X**

This section contains information about hardware requirements, jumper settings, motherboard diagrams, and daughter board layouts for the AI196-X Revisions 3 and 5 firmware.

**AI196 X.25 Protocol Overview**

When the AI196-X is used only for X.25 protocol communication, specific hardware information is applicable.

**AI196 Multi-Protocol Overview**

The AI196-I is the designation assigned to this card when it is used as a multi-protocol card and does not require the AI183 or AI185 card to communicate across the backplane. Refer to the *AI196-I User's Manual* for more information.

**Figure 7-35: AI196-X Faceplate**

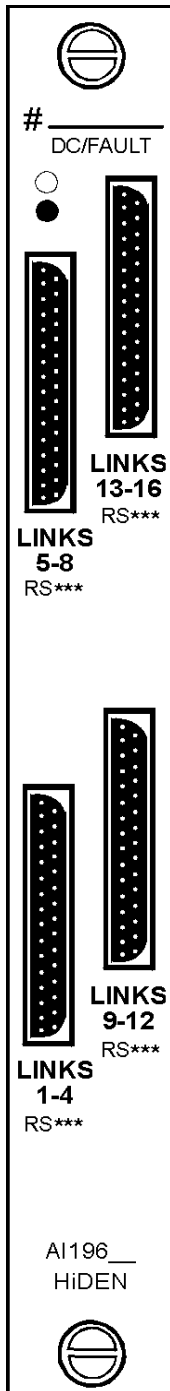

**AI196-X Faceplate and Connectors**

The following is a description of the faceplate and connectors associated with the AI196-X.

- DC/FAULT This green LED indicates the card is ON and receiving DC power. If the red LED is illuminated, a fault has been detected.
- LINKS 13-16 This connector is used for LINKS 13 through 16.
- LINKS 5-8 This connector is used for LINKS 5 through 8.
- LINKS 9-12 This connector is used for LINKS 9 through 12.
- LINKS 1-4 This connector is used for LINKS 1 through 4.

**Table 7-28: AI196-X Faceplate Variations**

[Table 7-28](#) lists the faceplate variations for the AI196-X.

Faceplate	Links 1-4	Links 5-8	Links 9-12	Links 13-16
AI196-XECV4	RS-530	RS-530	RS-530	V.35
AI196-XEG	RS-530	RS-530	RS-530	RS-530
AI196-XRCV4	RS-232	RS232	RS232	V.35
AI196-XR4	RS-232	RS-530	RS-530	RS-530
AI196-XR4V4	RS-232	RS-530	RS-530	V.35
AI196-XR4V8	RS-232	RS-530	V.35	V.35
AI196-XR8	RS-232	RS-232	RS-530	RS-530
AI196-XR8V4	RS-232	RS-232	RS-530	V.35
AI196-XRC	RS-232	RS-232	RS-232	RS-530
AI196-XRG	RS-232	RS-232	RS-232	RS-232

### AI196-X Revision 3 Jumper Settings

[Table 7-29](#) lists the default jumper settings for the AI196-X Revision 3. Refer to these settings in the event that the default settings change by accident (e.g. the card falls on the floor and a jumper strap falls off).



**Caution:** Do not change jumpers on the motherboard. If you do, the card may not function properly.

**Table 7-29: AI196-X Revision 3 Jumper Settings**

Jumper	Setting
J1	Diagnostic port
J2	Removed
J3	Removed
J4	Installed on 1-2
J5	Removed
J10	Installed on 1-2
J11	Installed on 1-2
J12	Installed on 1-2
J13	Installed on 2-3
J14	Installed on 1-2
J15	Installed on 1-2
J16	Removed
J17	Installed on 2-3
J18	Installed on 2-3
J19	Installed on 2-3
J20	Installed on 1-2
J21	Installed on 2-3
J22	Removed

### AI196-X Revision 3 Card Layout

Figure 7-36 displays the AI196-X card layout.

Figure 7-36: AI196-X Revision 3 Card Layout

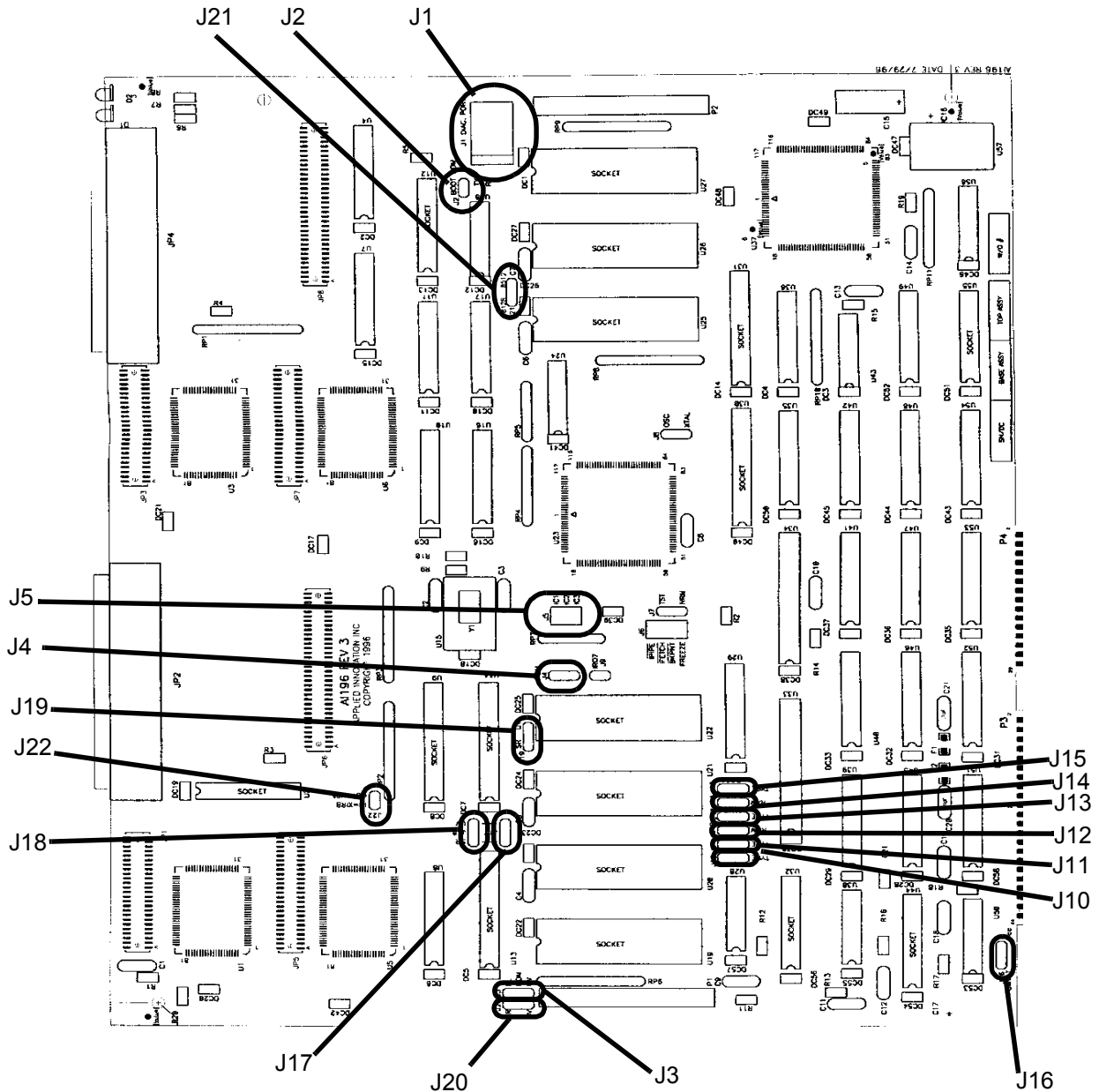



### AI196-X Revision 5 Jumper Settings

[Table 7-30](#) lists the default jumper settings for the AI196-X Revision 5. Refer to these settings in the event that the default settings change by accident (e.g. the card falls on the floor and a jumper strap falls off).



**Caution:** Do not change jumpers on the motherboard. If you do, the card may not function properly.

**Table 7-30: AI196-X Revision 5 Jumper Settings**

Jumper	Setting
J1	Diagnostic port
J2	Removed
J3	Removed
J4	Installed on 1-2
J5	Removed
J10	Installed on 1-2
J11	Installed on 1-2
J12	Installed on 1-2
J13	Installed on 2-3
J14	Installed on 1-2
J15	Installed on 1-2
J16	Removed
J17	Installed on 2-3
J18	Installed on 2-3
J19	Installed on 2-3
J20	Installed on 1-2
J21	Installed on 2-3

### AI196-X Revision 5 Card Layout

[Figure 7-37](#) displays the AI196-X Revision 5 card layout.

**Figure 7-37: AI196-X Revision 5 Card Layout**

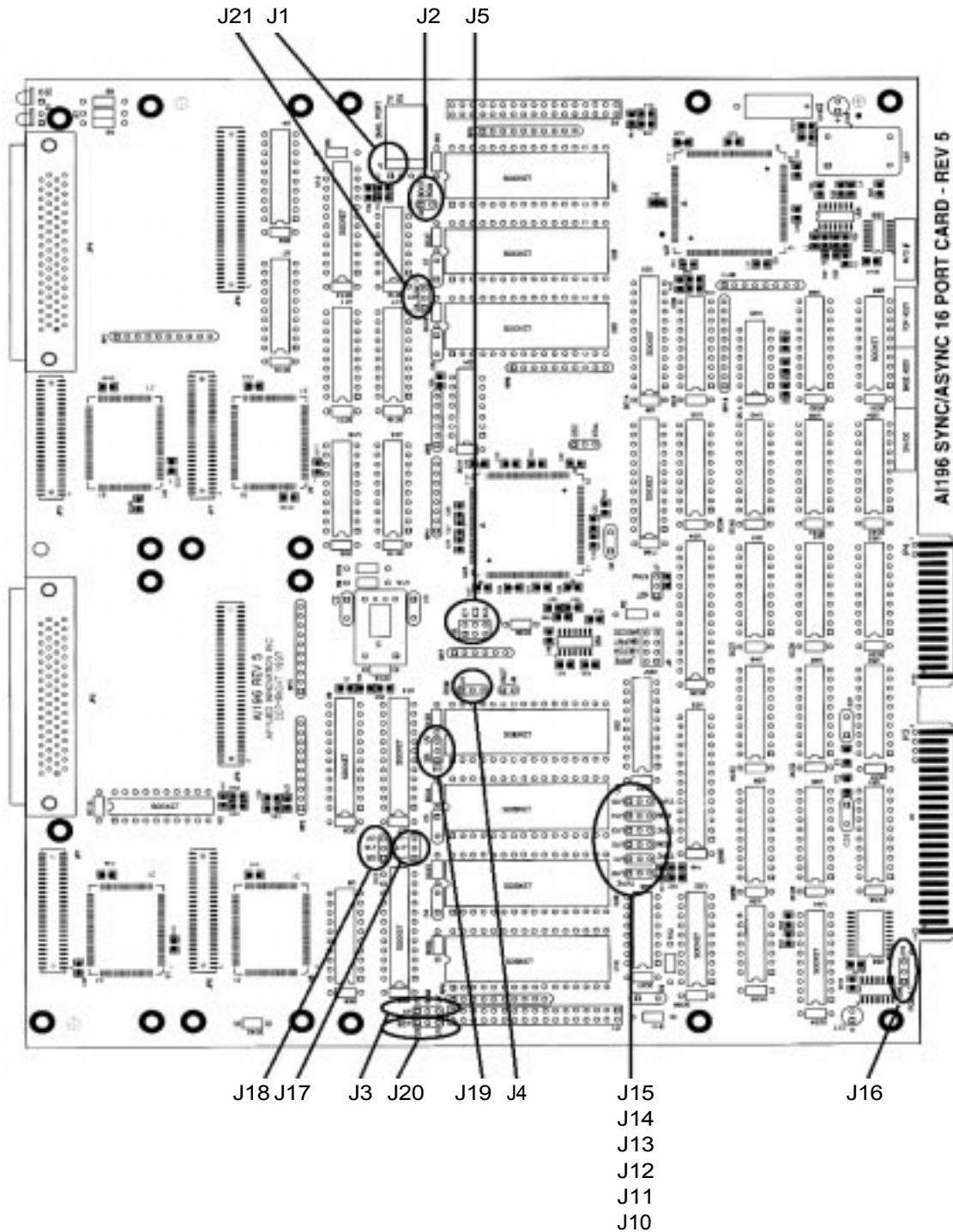

### B016 Daughterboard Jumper Settings

The AI196-X requires four daughterboards for the link interface. Each B016 RS232 daughterboard has four pairs of jumpers, one pair for each link, which must be set for either internal or external clocking. The default is internal clocking. [Table 7-31](#) lists the jumper settings for the B016 daughterboard.

**Table 7-31: B016 Daughterboard Jumper Settings**

Jumper	Internal Clocking (default)	External Clocking
JP2	Link 1, 5, 9, 13 Both installed	Link 1, 5, 9, 13 Both removed
JP3	Link 2, 6, 10, 14 Both installed	Link 2, 6, 10, 14 Both removed
JP4	Link 3, 7, 11, 15 Both installed	Link 3, 7, 11, 15 Both removed
JP5	Link 4, 8, 12, 16 Both installed	Link 4, 8, 12, 16 Both removed

### B016 Daughterboard Layout

Figure 7-38 displays the B016 daughterboard layout.

Figure 7-38: B016 Daughterboard Layout

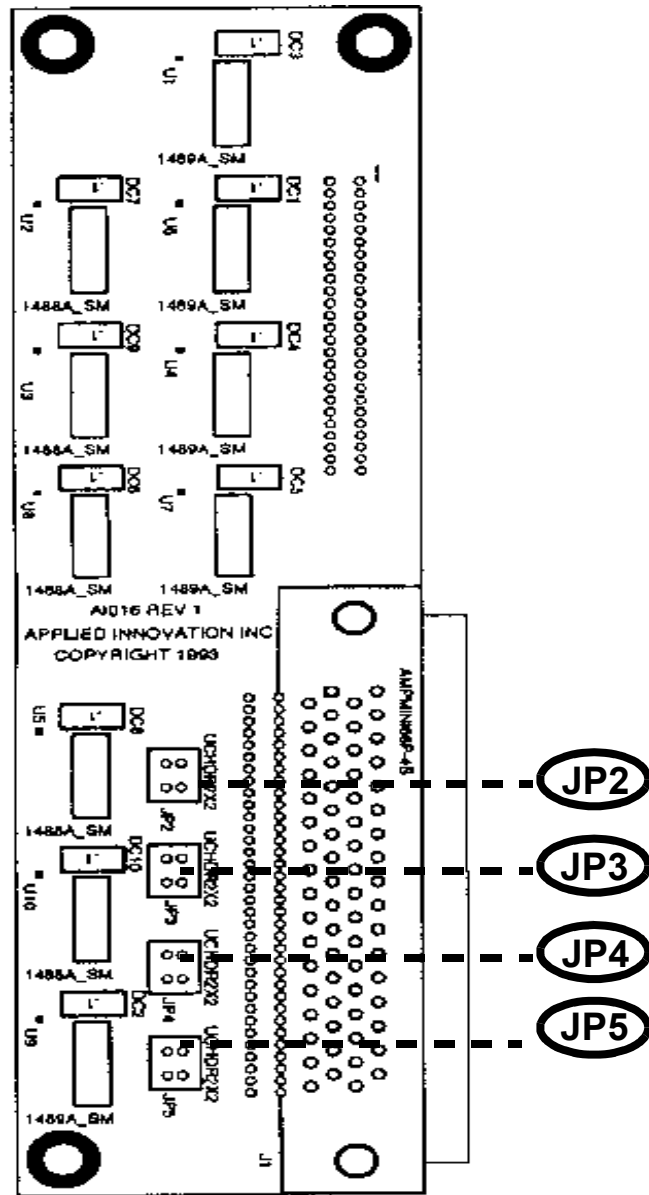

### B017 Daughterboard Jumper Settings

[Table 7-32](#) displays the default jumper settings for the B017 daughterboard. The AI196-X requires four daughterboards for the link interface. Each B017 EIA530 daughterboard has four sets of jumpers, one set for each link, which must be set for either internal or external clocking. The default is internal clocking.

**Table 7-32: B017 Daughterboard Jumper Settings**

<b>Jumper</b>	<b>Internal Clocking (default)</b>	<b>External Clocking</b>
JP9	Link 1, 5, 9, 13 Installed on 9-16	Link 1, 5, 9, 13 Installed on 1-8
JP10	Link 2, 6, 10, 14 Installed on 9-16	Link 2, 6, 10, 14 Installed on 1-8
JP8	Link 3, 7, 11, 15 Installed on 9-16	Link 3, 7, 11, 15 Installed on 1-8
JP7	Link 4, 8, 12, 16 Installed on 9-16	Link 4, 8, 12, 16 Installed on 1-8

### B017 Daughterboard Layout

Figure 7-39 displays the B017 daughterboard layout.

Figure 7-39: B017 Daughterboard Layout

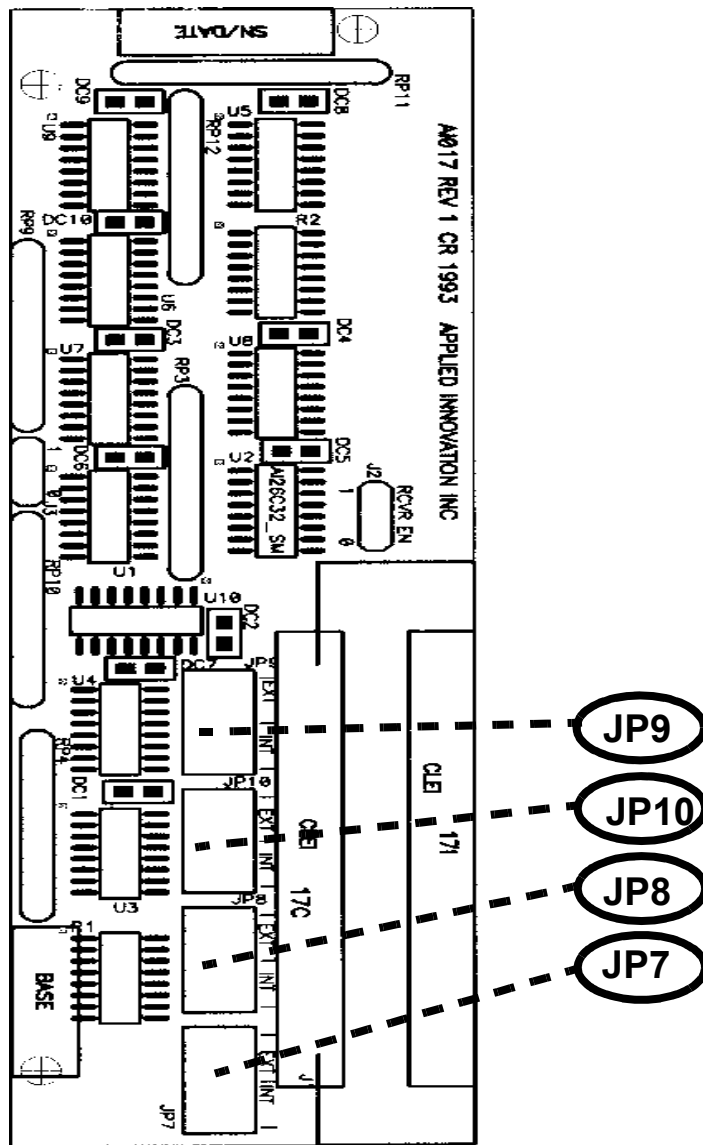

### B032 Daughterboard Jumper Settings

The AI196-X requires four daughterboards for the link interface. Each B032 V.35 daughterboard has four sets of jumpers, one set for each link, which must be set for either internal or external clocking. The default is internal clocking. [Table 7-33](#) lists the jumper settings for the B032 daughterboard.

**Table 7-33: B032 Daughterboard Jumper Settings**

Jumper	Internal Clocking (default)	External Clocking
JP3	Link 9 or 13 All installed	Link 9 or 13 All removed
JP4	Link 10 or 14 All installed	Link 10 or 14 All removed
JP5	Link 11 or 15 All installed	Link 11 or 15 All removed
JP6	Link 12 or 16 All installed	Link 12 or 16 All removed

**Note:** Only two links on this daughterboard may be used at one time. Using more than two links could result in lost data.

### B032 Daughterboard Layout

Figure 7-40 displays the B032 daughterboard layout.

Figure 7-40: B032 Daughterboard Layout

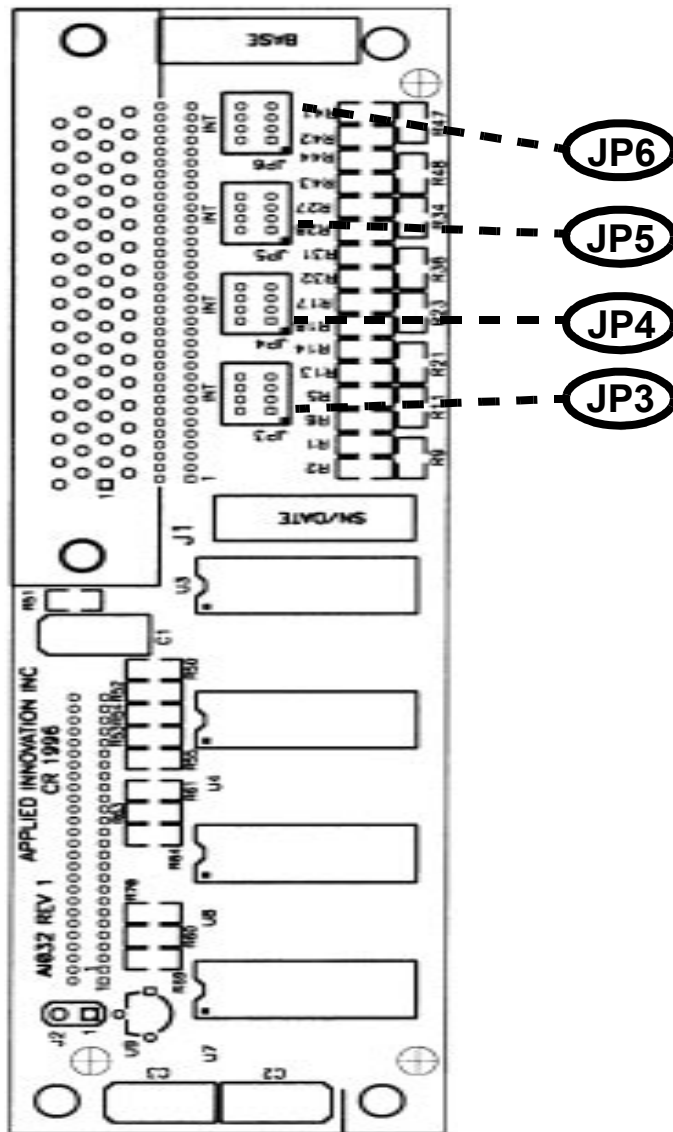



## AI198

This section describes the physical aspects of the AI198 for Revision 1 and Revision 4a.



**Caution:** The AI198 can only be used with a Revision 9 or newer backplane.

### AI198 Revision 1

#### *Features*

- Ethernet TCP/IP  
The AI198 has an Ethernet interface which supports a TCP/IP stack, SNMP, FTP, and Telnet.
- BNC Ethernet Data Port (10Base2)  
An Ethernet port allows direct network communication with the CLC. This provides access for network management tools.
- Soft-Configurable Slot Density  
Slot density configuration is handled through the CLC software. The physical switch found on earlier CLCs has been removed.
- Enhanced Backplane Scanning  
Instead of scanning the entire range of available ports on the backplane, only ports that are actually connected are scanned for information. This dramatically increases scanning efficiency in many situations.

#### *Requirements*

This version of the AI198 functions in either of the following system chassis:

- An AI180-CP chassis with Revision 9 backplane or higher
- An AI130 chassis with Revision 3 backplane or higher.

#### *Battery Warning*

There is a danger of explosion if the lithium battery is incorrectly replaced. Replace the battery with only the same or equivalent type recommended by the manufacturer. Dispose of used batteries according to manufacturer's instructions.

**Figure 7-41: AI198 Rev. 1 Faceplate**

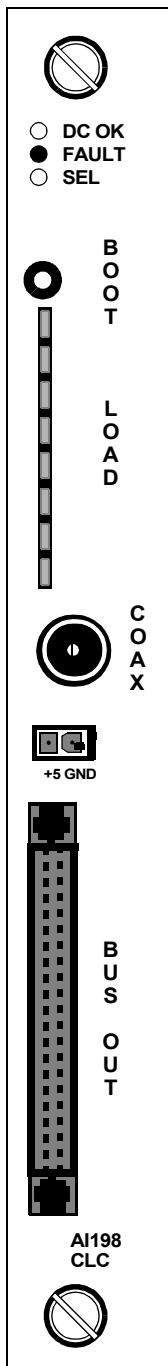

**AI198 Revision 1 Faceplate and Connectors**

The following is a description of the faceplate and connectors associated with the AI198 Revision 1.

- DC OK This green LED should always be on when the system is powered up. It indicates that 5 volts are being supplied to the processor.
- FAULT This LED should be off when the system is operating properly. When this red light is on, this controller module has failed.
- SEL This green LED identifies which CLC is active. In a system with redundant logic (two CLCs), only one should be active at any given time.
- BOOT When pushed, this button will reset the entire AI180. The AI180 will restart using its saved configuration settings. Push this button after a fault has been corrected in order to switch back to the primary CLC.



**Caution:** BOOT will cause the system to terminate any calls in place.

- LOAD These eight green LEDs light in a specific pattern that indicates the status of system initialization, software downloading, and some system functions.
- COAX This connection is the BNC Thinwire Ethernet data port.
- +5 GND Connecting a DC multimeter to this outlet provides a reading of the 5 VDC output from the RDC180-P power supply. The power supply may then be adjusted to the precise output voltage required.
- BUS OUT A ribbon cable is used to connect this expander interface to an additional chassis where more interface cards can be housed. Each expander chassis must have an expander card in the appropriate CPU slot. Expander cards allow multiple chassis to be daisy-chained together.

**AI198 Revision 1 Jumper Settings**

[Table 7-34](#) shows the default jumper settings for the AI198 Revision 1.

**Table 7-34: AI198 Revision 1 Jumper Settings**

<b>Jumper</b>	<b>Setting</b>
J2	removed
J3	installed on 1-2
J4	installed on 1-2
J5	installed on 1-2
J6	installed on 2-3
J7	installed on 2-3
J8	installed on 2-3
J9	removed
J10	installed on 2-3
J11	installed on 1-2
J12	removed
J13	removed
J14	installed on 1-2
J15	installed on 1-2
J16	installed on 1-2
J17	installed on 1-2
J18	installed on 2-3
J19	removed
J20	installed on 1-2
J21	removed
J22	installed on 1-2
J23	installed on 1-2
J24	installed on 1-2
J25	installed on 1-2
J26	removed
J27	installed on 2-3
J28	removed

### AI198 Revision 1 Card Layout

Figure 7-42 displays the card layout for the AI198 Revision 1.

Figure 7-42: AI198 Revision 1 Card Layout

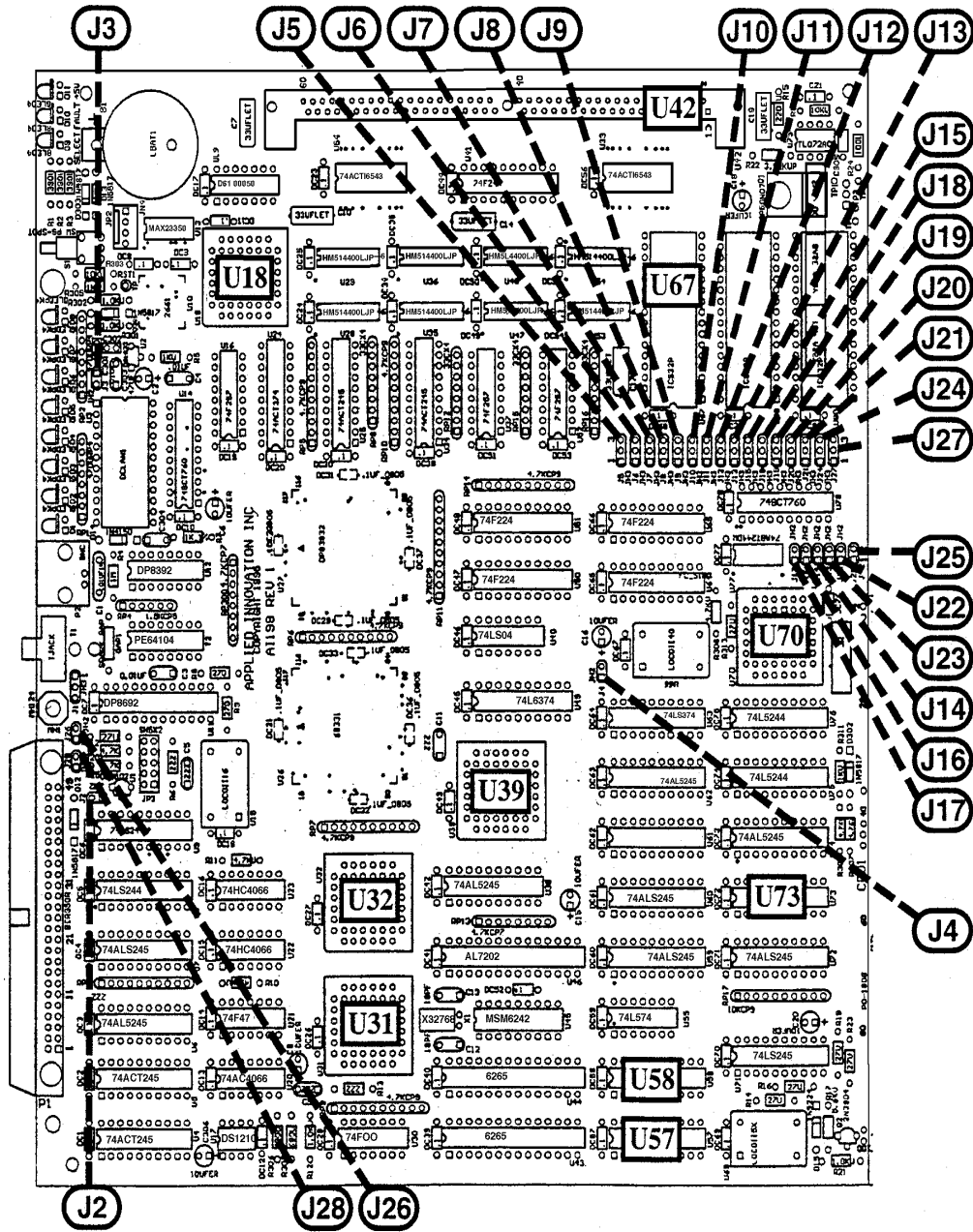

## AI198 Revision 4a

### *Features*

**Note:** The current AI198 board is labeled Revision 3 on the silkscreen. However, this manual documents the current AI198 board as Revision 4a because of these new features:

Revision 4a is enhanced with:

- 10BaseT Ethernet port
- Changes in default jumper settings
- Additional jumpers on the motherboard

**Figure 7-43: AI198 Rev. 4a Faceplate**

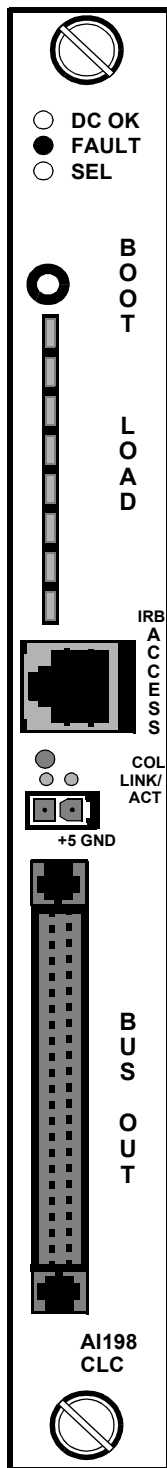

**AI198 Revision 4a Faceplate and Connectors**

The following describes the faceplate and connectors associated with Revision 4a of the AI198.

- DC OK                      This green LED is always on when the system is powered up and indicates 5 volts are being supplied to the processor.
- FAULT                     This LED is off when the system is operating properly. When the red light is on, this controller module had failed.
- SEL                        This green LED identifies which CLC is active. In a system with redundant logic (two CLCs), only one should be active at any given time.
- BOOT                     When pushed, this button resets the entire AI180. The AI180 will restart using its saved configuration settings. Push this button after a fault has been corrected to switch back to the primary CLC.
- LOAD                     These eight, green LEDs light in a specific pattern that indicates the status of system initialization, software downloading, and some system functions.
- IRB ACCESS              This connection is the Twisted Pair Ethernet data port.
- COL                        This green LED indicates when an Ethernet collision is detected.
- LINK                      This green LED indicates that valid link integrity pulses are being received.
- ACT                        This green LED indicates that Ethernet data is being transmitted by this CLC.
- +5 GND                    Connecting a DC multimeter to this outlet provides a reading of the 5 VDC output from the RDC180-P power supply. The power supply may then be adjusted to the precise output voltage required.
- BUS OUT                 A ribbon cable is used to connect this expander interface to an additional chassis where more interface cards can be housed. Each expander enclosure must have an expander card.

### AI198 Revision 4a Jumper Settings

[Table 7-35](#) shows the default jumper settings for the AI198 Revision 4a. Refer to the [AI198 Revision 4a Card Layout](#) section for the location of new jumpers J29 and J30.

**Table 7-35: AI198 Revision 4a Jumper Settings**

Jumper	Setting	Comments
J2	removed	Program ID
J4	installed on 1-2	199IPC
J5	installed on 1-2	BootROM
J6	installed on 2-3	BootROM
J7	installed on 2-3	BootROM
J8	installed on 2-3	BootROM
J9	installed on 2-3	BootROM
J10	installed on 2-3	BootROM
J11	installed on 2-3	JEDEC
J12	installed on 1-2	JEDEC
J13	removed	JEDEC
J14	installed on 1-2	IRB
J15	installed on 2-3	JEDEC
J16	installed on 1-2	JRB
J17	installed on 1-2	JRB
J18	installed on 2-3	BootROM
J19	removed	JEDEC
J20	installed on 2-3	JEDEC
J21	installed on 1-2	JEDEC
J22	installed on 1-2	IRB
J23	installed on 1-2	IRB
J24	removed	JEDEC
J25	installed on 1-2	IRB

<b>Jumper</b>	<b>Setting</b>	<b>Comments</b>
J26	removed	Config
J27	installed on 2-3	BootROM
J28	removed	Config
J29	installed on 1-2	HBE enabled
J30	installed on 1-2	Link integrity text enabled



## AI198 Revision 4a Card Layout

Figure 7-44 displays the card layout for the AI198 Revision 4a.

Figure 7-44: AI198 Revision 4a Card Layout

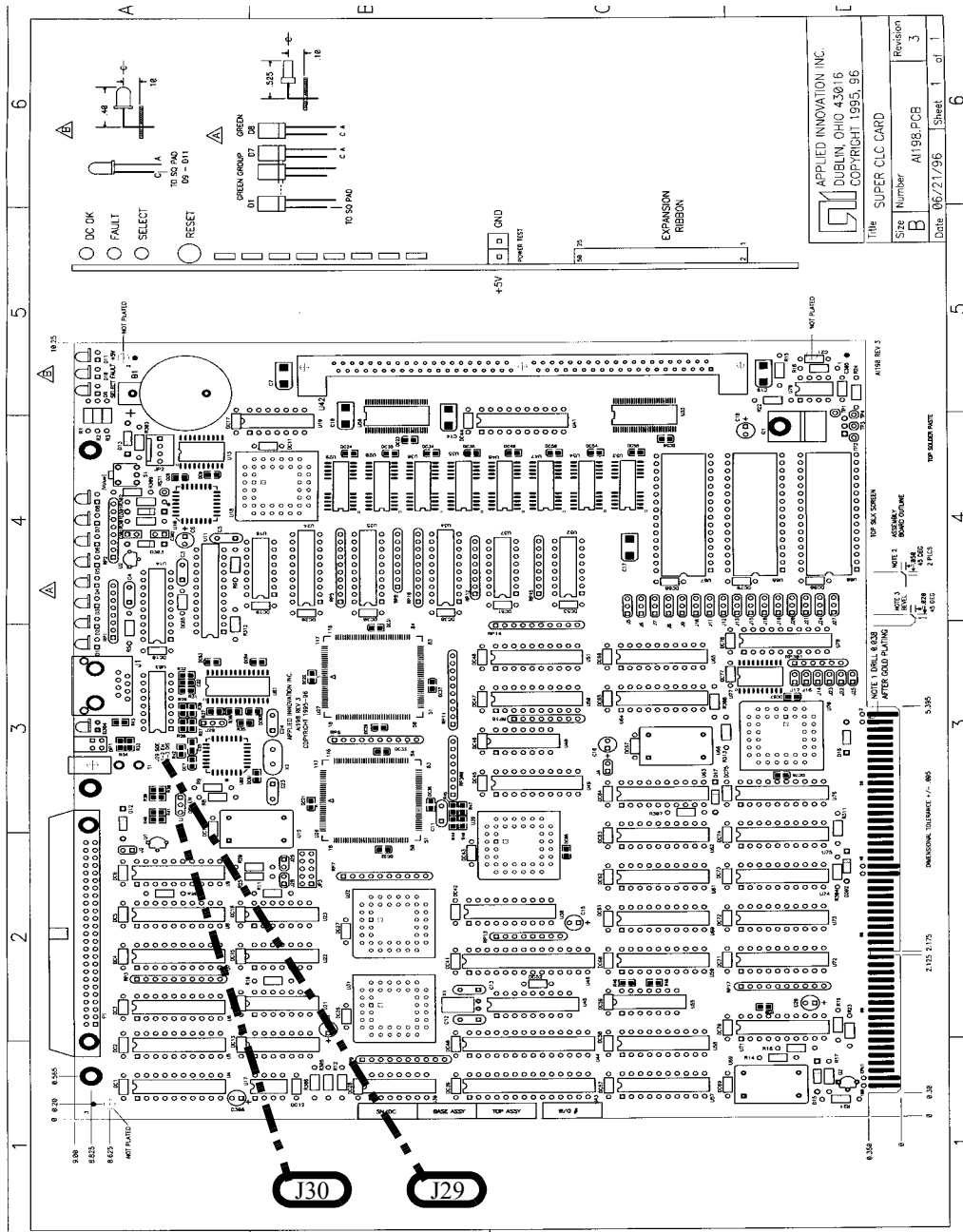

## AI285

The AI285 network interface card provides 16 physical ports for RS232 async connections between NEs (Network Elements) and OSSs (Operational Support Systems) in a carrier's network. Each port's baud rate can be configured without interrupting communications on the other ports. Each port operates at speeds up to 115 Kbps.

### Typical Applications

The AI285 can be used in an AI shelf with other AI network interface cards to provide 16 RS232 async interfaces.

The AI285 meets Bellcore NEBS (Network Equipment Building Standards) to ensure reliable operations in Central Offices and other telecommunications facilities.



**Caution:** The AISwitch and its peripherals contain electrostatic sensitive components. Exercise proper handling, shipping, and storage precautions.

### AI285 Hardware Components

The AI285 has four high density connectors that provide 16 async ports. Individual ports are derived by connecting a cable assembly to each connector or by using a distribution panel.

All options on the AI285 are configured using either the AI198 menu system or the LocalView menu system. The AI285 has no jumper or switches that need to be set.

**Figure 7-45: AI285 Front Panel Components**

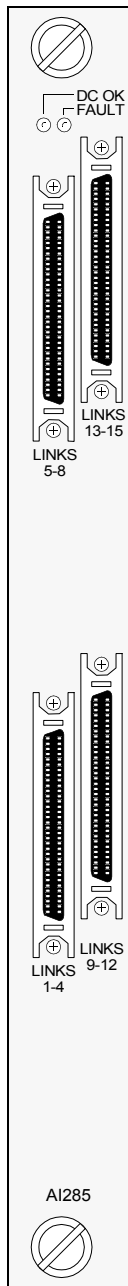

Figure 7-45 shows the front panel components of the AI285 and [Table 7-36](#) describes their function.

**Table 7-36: Front Panel Components**

Component	Description
DC LED	Illuminates when +5 V is present
FAULT LED	Illuminates if the card fails
LINKS 5-8 Connector	Provides four async ports
LINKS 13-16 Connector	Provides four async ports
LINKS 1-4 Connector	Provides four async ports
LINKS 9-12 Connector	Provides four async ports

### Technical Specifications

[Table 7-37](#) lists the specifications of the AI285.

**Table 7-37: Technical Specifications**

Component	Description
I/O Ports	16 asynchronous (selectable per port during configuration)  Individual ports are derived by using a CAB257 cable assembly for each connector or by using a distribution panel, Model DP196, and a CAB162 cable with each connector.
Port Speed	300 bps to 115 Kbps
Electrical Interfaces	RS232
Installation	Requires one slot in an AI chassis (can be hot swapped)
Power Consumption	4.0 A, maximum

## AI294

This section provides an overview of the AI294. The AI294 is an Ethernet switch that plugs into the AISwitch Series 180 chassis. The AI294 is available in three models with each providing a different physical interface.

The AI294 provides nine external 10-megabits per second ports for connecting multiple devices or networks. It also has one internal port that connects to the IRB so the AI294 can communicate with AI cards.

### Purpose

The AI294 controls and directs data traffic between devices and networks. Each port operates independently of each other. The AI294 switches traffic between its ports and only switches traffic onto the IRB when required. The AI294

- Interconnects LAN segments into a single logical network to decrease traffic congestion between segments
- Segments larger LANs into logical workgroups to decrease traffic between segments
- Avoids Ethernet channel overloading
- Prevents collisions
- Reduces overall network congestion
- Improves network performance

### Features

The AI294 provides:

- Three physical interfaces for connecting to a variety equipment
- Nine external 10-megabits per second ports for connecting multiple devices or networks at LAN speed while using the existing infrastructure
- One internal port connecting to the IRB allowing communication with other AI cards
- Half or full duplex operation for each port
- A self-learning address table to automatically learn and build connections between network elements
- User defined filtering on any port or address to filter out or reroute broadcast traffic between specified nodes on LAN segments
- Store and forward switching for reducing delays and collisions on port-to-port data transmissions by filtering and forwarding information at 12,000 packets per second

- A spanning tree to reduce loops
- Flow control for reducing dropped packets and time consuming regeneration of dropped packets by higher level applications.
- Local and remote switch access allowing configuration through the external console port or a telnet session
- Downloadable firmware for easy upgrading
- SNMP management

**Figure 7-46: AI294 Faceplate**

### AI294 Faceplate and Connectors

The following is a description of the faceplate and connectors associated with all models of the AI294.

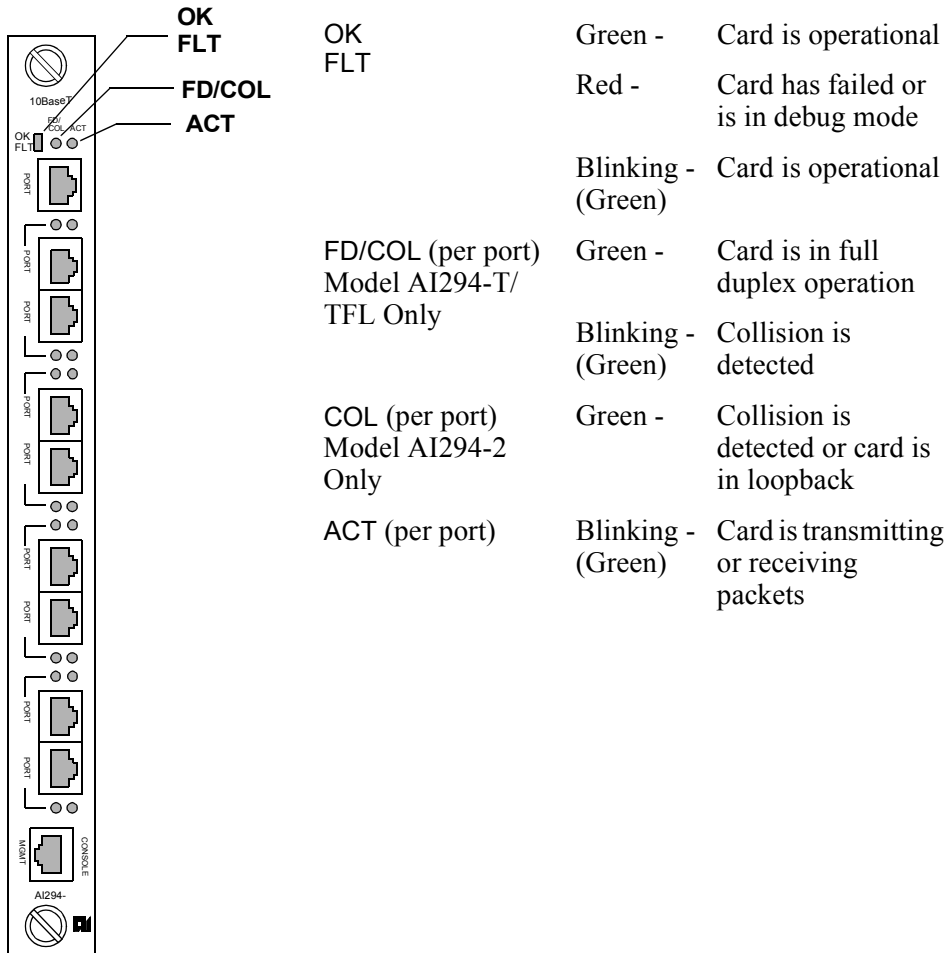

## Technical Specifications

[Table 7-38](#) lists the specifications for all models of the AI294

**Table 7-38: AI294 Technical Specifications**

Specification	Description
Physical Interfaces (Three types, model dependent)	Model AI294-2 <ul style="list-style-type: none"> <li>● 9 10Base2 ports (BNC connectors)</li> <li>● 1 IRB port</li> </ul> Model AI294-T <ul style="list-style-type: none"> <li>● 9 10BaseT ports (RJ45 connectors)</li> <li>● 1 IRB Port</li> </ul> Model AI294-T/FL <ul style="list-style-type: none"> <li>● 7 10BaseT ports (RJ45 connectors)</li> <li>● 2 10BaseFL ports (SC connectors)</li> <li>● 1 IRB port</li> </ul>
Power Consumption	Model AI294-2: 6.63 A Model AI294-T: 4.63 A Model AI294-T/FL: 5.2 A
Installation	<ul style="list-style-type: none"> <li>● Requires 1 chassis slot in the AI180 chassis</li> <li>● Can be hot swapped</li> </ul>
Standards Supported	<ul style="list-style-type: none"> <li>● FDSE (Full Duplex Switched Ethernet)</li> <li>● IEEE 802.3</li> <li>● IEEE 802.1d (Bridge/Spanning Tree)</li> <li>● SNMP V1</li> <li>● MIB II (RFC 1213)</li> <li>● Bridge MIB (RFC 1493)</li> <li>● Ethernet MIB (RFC 1398)</li> </ul>
Emissions and Safety	<ul style="list-style-type: none"> <li>● FCC Part 15, Sub. J, Class A</li> <li>● ETL (UL-1950), TUV/VDE, CSA</li> <li>● NEBS (GR.63)</li> </ul>
Buffers	64 KB per port

Specification (Continued)	Description
Addresses	1,000 MAC addresses
Addresses Table	<ul style="list-style-type: none"> <li>● Transparent</li> <li>● Automatic self-learning at full wire speed</li> <li>● Cache aging time manageable</li> <li>● Custom filtering by hardware address and port</li> </ul>
Store and Forward Switching	Provides complete runt and error filtering on all packets. Flow control prevents packet loss.
Network Management	In-band and out-of-band SNMP with MIB II, private MIB, and out-of-band serial console support
Filter/Forward Rate	12,000 pps per port (80,000 pps per card)
Learning Rate	148,700 pps
Status Indicators (per port)	Operational, transmit and receive activity, collision or loopback, debug mode
Boot and Configuration	<ul style="list-style-type: none"> <li>● NVRAM configuration loaded on power up</li> <li>● Fully downloadable</li> <li>● Firmware local/remote downloadable</li> </ul>

### AI294 Physical Interfaces

[Figure 7-47](#) shows the different models of the AI294.

**Figure 7-47: AI294 Physical Interfaces**

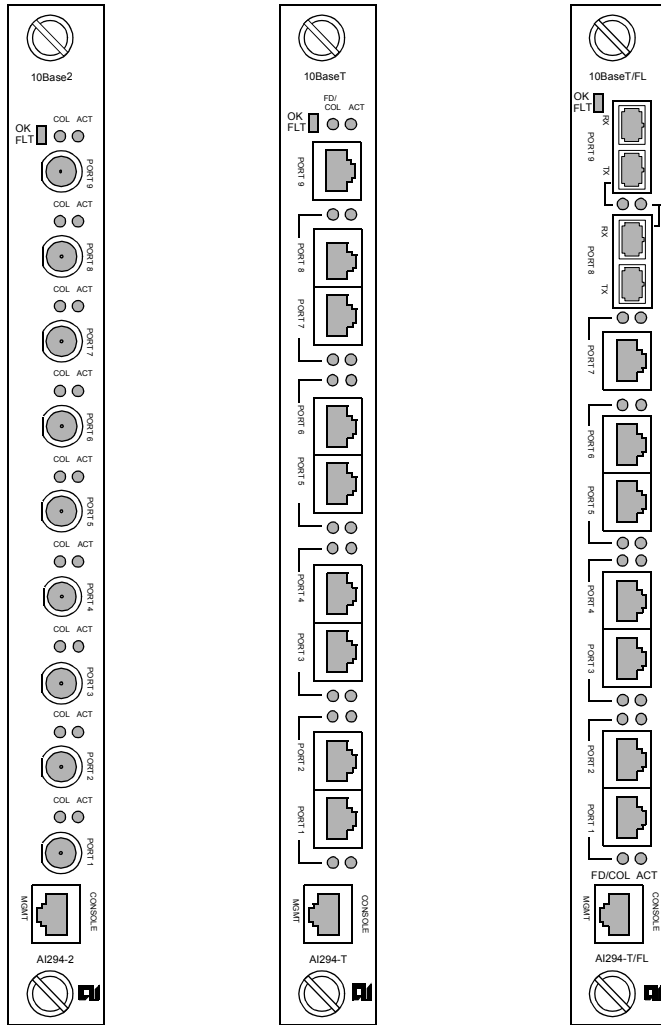

**Model AI294-2**

9 10Base2  
1 IRB

**Model AI294-T**

9 10BaseT  
1 IRB

**Model AI294-T/FL**

7 10BaseT  
2 10BaseFL  
1 IRB



## AI296

The AI296 network interface card provides 16 physical ports for async or X.25 connections between NEs (Network Elements) and OSSs (Operational Support Systems) in a carrier's network. Each port can be configured for either async or X.25 operation. Protocol changes to a single port can be made without interrupting communications on the other ports. Each port operates at speeds up to 128kbps.

### Typical Applications

The AI296 can be used in an AI shelf with other AI network interface cards to provide single, multiple, and redundant trunk lines with a variety of physical port and protocol types, including coax, EIA-232, EIA-530, X.25, V.35, IP, async, and others. When combined with other AI network interface cards, typical applications include collection, concentration and trunking of alarm and event messages from many NEs to one or more OSSs and operations centers.

The AI296 meets Bellcore NEBS (Network Equipment Building Standards) to ensure reliable operations in Central Offices and other telecommunications facilities.



**Caution:** The AISwitch and its peripherals contain electrostatic sensitive components. Exercise proper handling, shipping, and storage precautions.

### AI296 Hardware Components

The AI296 has four high density connectors that provide 16 async or X.25 ports. Individual ports are derived by connecting a cable assembly to each connector or by using a distribution panel.

All options on the AI296 are configured using either the AI198 menu system or the LocalView menu system. The AI296 has no jumper or switches that need to be set.

**Figure 7-48: AI296 Front Panel Components**

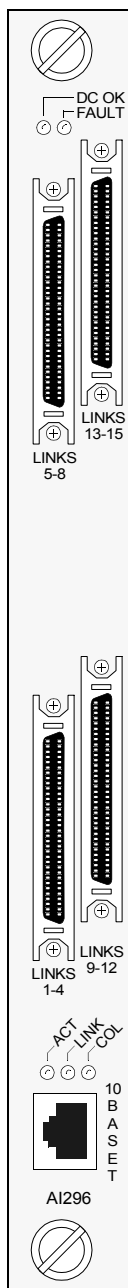

Figure 7-45 shows the front panel components of the AI296 and Table 7-36 describes their function.

**Table 7-39: Front Panel Components**

Component	Description
DC LED	Illuminates when +5 V is present
FAULT LED	Illuminates if the card fails
LINKS 5-8 Connector	Provides four async or X.25 ports
LINKS 13-16 Connector	Provides four async or X.25 ports
LINKS 1-4 Connector	Provides four async or X.25 ports
LINKS 9-12 Connector	Provides four async or X.25 ports
10BASE Connector	Not used (for future use)

**Technical Specifications**

Table 7-37 lists the specifications of the AI296.

**Table 7-40: Technical Specifications**

Component	Description
I/O Ports	16 asynchronous or X.25 (selectable per port during configuration)  Individual ports are derived by using a CAB257 cable assembly for each connector or by using a distribution panel, Model DP196 and a CAB162 cable for each connector.
Port Speed	1200 bps to 128 Kbps or external clocking (selectable per port during configuration)
Electrical Interfaces	RS-232, RS-530, and V.35 (selectable per port during configuration)
Installation	Requires one slot in an AI chassis (can be hot swapped)
Power Consumption	5.21 A, maximum

**AI2524**

This section describes the AI2524 hardware including the panel, cable connections, and firmware.

**Power Requirements**

[Table 7-41](#) lists the power requirements associated with the AI2524.

**Table 7-41: AI2524 Power Requirements**

<b>Power</b>	<b>Current</b>
+5V	3.5A Max
+12V	0.5A Max
-12V	0.5A Max

**Figure 7-49: AI2524 Faceplate and Connectors (base card)**

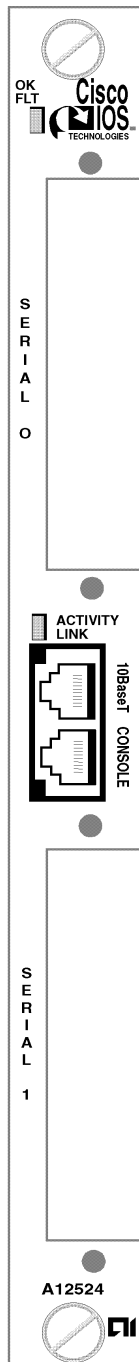

The following is a description of the faceplate and connectors associated with the AI2524 base card.

OK	Bi-color LED, red indicates power on (+5V) changes to green to indicate system OK.
FLT	
SERIAL 0	Serial interface module location
ACTIVITY LINK	Bi-color LED, yellow indicates data activities in the LAN, green indicates link OK, red indicates collisions on the LAN
10BaseT	RJ-45 Ethernet 10BaseT port
CONSOLE	RJ-45 Console port
SERIAL 1	Serial interface module location

The Console port provides an asynchronous serial connection to the router either locally with a console terminal or remotely with a modem. Depending on the cable and adapter used, this port appears as a DTE or DCE device at the end of the cable.

The AI2524 includes cables and adapters to connect a console terminal, an ASCII terminal or PC running terminal emulation software, to the console port. To connect an ASCII terminal to the console port, use the RJ-45 roll over cable with the female RJ-45-to-DB-25 adapter (labeled Terminal). To connect a PC running terminal emulation software to the console port, use the RJ-45 roll-over cable with the female RJ-45-to-DB-9 adapter (labeled Terminal).

The default parameters for the console port are 9600 baud, 8 data bits, no parity, and 2 stop bits. The console port does not support flow control.

### AI2524 Jumper Settings

Table 7-42 lists the jumper settings for the AI2524.

**Table 7-42: AI2524 Jumper Setting**

Jumper	Setting
J3	1-2
J4	OPEN
J5	1-2



**Caution:** Do not change the jumpers on the motherboard. This may cause the card not to function properly.

**Figure 7-50: AI2524 T1 CSU/DSU Faceplate**

### AI2524 T1 CSU/DSU Faceplate and Connectors

The following is a description of the faceplate and connectors associated with the AI2524. This interface is an integrated CSU/DSU that supports full or fractional T1 leased line services.

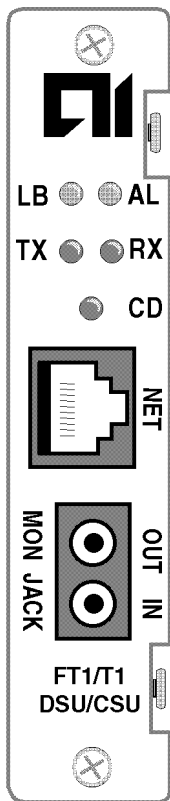

- LB Loopback LED  
Yellow when loopback set; normally dark
- AL Alarm LED  
Normally dark, yellow to indicate alarm condition
- TX Transmit LED  
Green when data being transmitted
- RX Receive LED  
Green when data being received
- CD Carrier Detect LED  
Green when a carrier signal is detected
- NET RJ-48C network port
- OUT IN  
MON JACK Monitor Jack

**Figure 7-51: AI2524  
4-Wire 56K  
CSU/DSU Faceplate**

**AI2524 4-wire 56K CSU/DSU Faceplate and Connectors**

The following is a description of the faceplate and connectors associated with the AI2524 4-wire 56K CSU/DSU.

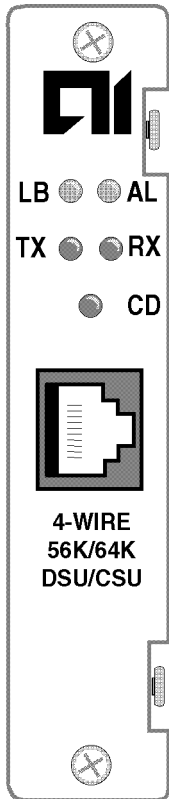

LB	Loopback LED Yellow when loopback set; normally dark
AL	Alarm LED Normally dark, yellow to indicate alarm condition
TX	Transmit LED Green when data being transmitted
RX	Receive LED Green when data being received
CD	Carrier Detect LED Green when a carrier signal is detected RJ-48S network port

**Figure 7-52: AI2524-5N1 Faceplate**

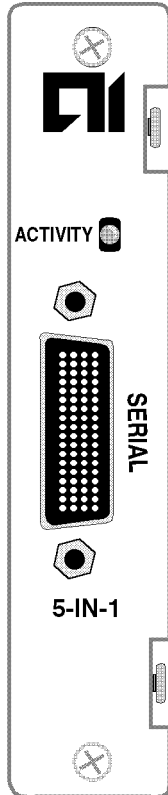

### AI2524 5-IN1 Faceplate and Connectors

The following is a description of the faceplate and connectors associated with the AI2524-5N1. This interface provides a cable interface to a synchronous serial line. Cables are available to provide these interfaces:

- RS-232 DTE or DCE
- EIA-530 DTE
- RS-449 DTE or DCE
- V.35, DTE or DCE, up to E1 speeds

ACTIVITY	LED flashes on activity
SERIAL	DB-60 Connector

The serial port on the five-in-one synchronous serial WAN module is a 60-pin D-type connector. The synchronous serial port, except for the EIA-530, can be configured as DTE or DCE, depending on the attached cable. All DTE serial ports require external clocking from a DSU/CSU or other DCE device.

You must use a special serial cable to connect the router to a modem or DSU/CSU. This cable is available from Applied Innovation and is usually ordered with the system.

**Figure 7-53: AI2524 ISDN/BRI Faceplate**

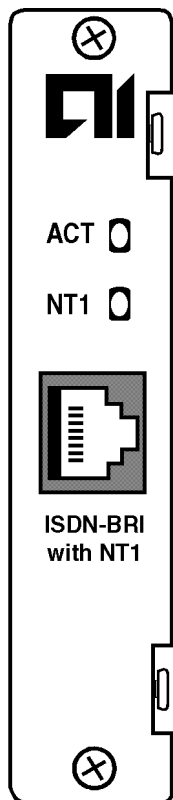

**AI2524 ISDN/BRI Faceplate and Connectors**

The following is a description of the faceplate and connectors associated with the AI2524 ISDN/BRI. This interface provides the digitalization of telephone network so that voice, data, text, graphics, music, video, and other source material can be provided to end users from a single end-user terminal over existing telephone wiring.

ACT	Activity LED
	Flashing LED indicates normal operation. Transmitting and receiving data normally.
NT1	Network Termination 1 LED
	If the NT1 LED is on, the router detects the ISDN link integrity signal at the U interface and the internal S/T interface, indicating that an ISDN connection has been established.
	If the NT1 LED blinks once per second, the ISDN connection at the U interface is up and the internal S/T interface is coming up. If this condition persists, the ISDN port is either not configured or configured incorrectly.
	If the NT1 LED blinks 8 times per second, the ISDN connection at the internal S/T interface is up and the U interface is coming up.
	If the NT1 LED is off, the router is not detecting the ISDN link integrity signal. Check the BRI cable connection.
ISDN-BRI with NT1	RJ-45 connector



# Chapter 8: RDC180-P Power Supply

## Overview

The power supply provides power to the AISwitch. It converts incoming 48 volts to +5 volts, +12 volts, and -12 volts for the various cards in the AISwitch. Use two power supplies to provide redundant power sources for the AISwitch. Then if one power supply fails, the AISwitch will switch to the other power supply automatically. This switching does not affect the operation of the AISwitch.

Looking at the cabled side of the AISwitch, the power supplies are located in the upper right section.

**Figure 8-1: DC Power Supplies Location**

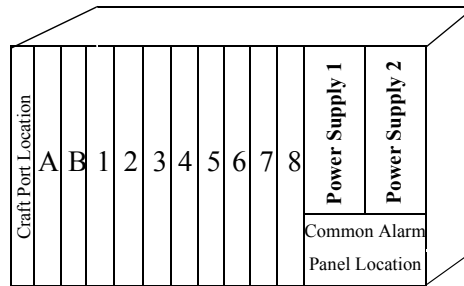

Normal operating conditions, when referenced in this document, are defined as follows: a redundant -48 volt central office power system in which the customer wishes to maintain redundancy.

## RDC180-P Technical Specifications

**Table 8-1: RDC180-P Technical Specifications**

Specification	Description
Dimensions	Height: 8 in. Width: 1.87 in. Depth: 9.5 in.
Weight	3.5 lbs.
Operating Environment	Temperature: 0-50 °C 0-95% relative humidity, non-condensing
Input Power Ratings	39 VDC to 63 VDC  Input voltages are isolated from the system frame ground.
Input Power Connectors	For the input use a 2-wire cage-clamp connector. Use one 2-position power connector, AI Part #20-033-001.  Refer to the <a href="#">RDC180-P Power Connector</a> section for more details regarding the connector.
Output Power Supply Ratings	+5 VDC at 20 A +12 VDC at 4.0 A -12 VDC at 4.0 A  The 12 volt DC outputs of the power supply do not require any adjustments. The +5 volt DC output is adjustable. Refer to the <a href="#">Adjusting Voltage</a> section for more details.
Internal Fusing	The input is protected by a 5 amp fuse, located on the power supply faceplate. Refer to the <a href="#">Connecting DC Power</a> section for details.

**Figure 8-2:  
RDC180-P Power  
Supply**

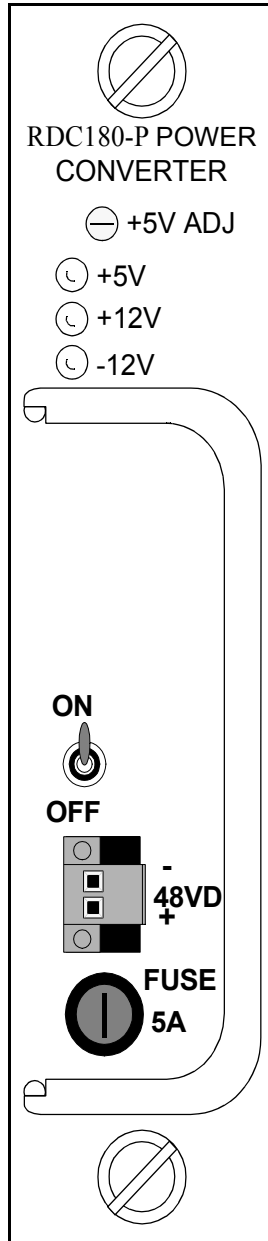

The following is a description of RDC180-P faceplate:

Mounting Screws	These screws located at the top and bottom of the faceplate secure the supply in the AISwitch.
5V ADJ	Adjustment potentiometer for the +5 VDC output.
+5V	This green LED reflects the status of the power supply's output. It illuminates when the +5-volt power supply operates correctly.
+12V	This green LED reflects the status of the power supply's output. It illuminates when the +12-volt power supply operates correctly.
-12V	This green LED reflects the output of the power supply. The LED illuminates when the -12-volt power supply operates correctly.
ON/OFF	Toggle switch to turn the power supply ON or OFF. This power switch should be in the up or ON position during operation of the AISwitch.
48VDC	This 48-volt input power connector accommodates a single battery feed. Insert a two-wire screw terminal connector (AI Part 20-033-001) in the power input header connector. Refer to the <a href="#">RDC180-P Input Power Wiring</a> figure for the wiring diagram.  The battery feed inputs are not reverse polarity protected. If the polarity is reversed on any input the unit will be harmed. Refer to the <a href="#">RDC180-P Power Connector</a> section for more details.
FUSE 5A	The location of the 5 amp fuse.

## Connecting DC Power

1. Connect the power cables to the -48 VDC distribution fuse panel.
2. Attach a screw terminal connector to the opposite ends of the power cables.
3. Using a voltage meter, check the polarity at each -48 VDC input screw terminal connector.



**Caution:** You must observe the proper polarity. Failure to do so will damage the converter and void the warranty.

4. Plug-in the -48 VDC power cable to the -48 VDC input of each power supply.
5. Turn each power supply ON.
6. Check the +5 volt, +12 volt, and -12 volt LED indicators for a green light.  
Proceed with system operation

## Installing a DC Power Supply

1. Remove the power supply from the shipping container and check for damage.
2. Locate the two slots directly above the Common Alarm Panel.
3. If a blank cover plate is installed in the power supply slot, then remove the cover plate.
4. Position the power supply with the green LED indicators to the left and with the flat metal edges of the supply aligned with the white plastic guides.

The supply's circuit board will be slightly above the white plastic guide/mounting rail.

See [Figure 8-1](#) for power supply location.

5. Gently slide the supply into the system enclosure until it stops.
6. Firmly press the faceplate until the internal connectors snap into place. The supply should not release when you gently tug on the panel.
7. Screw in the extended captive screws to lock the power supply in place.
8. Repeat steps 1 through 6 if installing a second power supply. If a second power supply is not going to be installed, install a blank cover plate (RDC180-BC) in the second position.
9. Connect the power cables to the -48VDC distribution fuse panel.
10. Attach a screw terminal connector to the opposite ends of the power cables.
11. Using a voltage meter, check the polarity of each -48VDC input screw terminal connector.



**Caution:** You must observe the proper polarity. Failure to do so will damage the converter and void the warranty.

12. Using a wired screw terminal connector, plug-in the -48 VDC power cable to the -48 VDC input of each power supply.
13. Turn each power supply ON.
14. Check the +5 volt, +12 volt, and -12 volt LED indicators on the power supply and common alarm panel for a green light.

Proceed with system operation.

## Replacing a DC Power Supply

If one of the power supplies fails, it may be replaced without affecting the operation of the AISwitch system.

1. Turn off the power switch for the supply that is to be replaced.
2. Disconnect the power cable at the -48 VDC distribution panel.
3. Loosen the large captive screws holding the converter in place.
4. Disconnect the -48 VDC power supply that is to be replaced.
5. Gripping the screws firmly, pull the supply out of the system enclosure.
6. Position the new/replacement supply with the green LED indicators to the left and with the flat metal edges of the supply aligned with the white plastic guides.

The circuit board will be slightly above the white plastic guide/mounting rail. See [Figure 8-1](#) for the specific location.

7. Gently slide the card into the system enclosure.
8. Firmly press the faceplate of the card until the internal connectors snap into place.
9. Screw in the extended captive screws to lock the power supply in place.
10. Reconnect the power cable at the -48 VDC distribution panel.
11. Using a voltage meter, check the polarity of each -48 VDC input connector.



**Caution:** You must observe the proper polarity. Failure to do so will damage the supply and void the warranty

12. Using the wired screw terminal connector, plug-in the -48 VDC power cable to the -48 VDC input of this new/replacement power supply.
13. Turn the new supply ON.
14. Check the +5 volt, +12 volt, and -12 volt LED indicators on the power supply and common alarm panel for a green light

Proceed with system operation.

**Replacing the  
RDC180-P Fuse**

The RDC180-P has a standard 5 amp, 125-volt slow blow fuse. The fuse is accessible from the face panel of the power supply.

**Replacing the 5 Amp Fuse**

1. Obtain a 5 amp fuse.
2. Switch the ON/OFF switch on the front of the power supply to the OFF position.
3. Unscrew the fuse holder 1/8 turn using a flat head screwdriver.
4. Take the fuse out of the fuse holder.
5. Put the new fuse in the fuse holder.
6. Insert the fuse holder back into the fuse housing. Screw it into place until the fuse holder locks into position.

## RDC180-P Power Connector

One input power connector is supplied with each RDC180-P DC power supply. The input connector on the power supply contains the male pins. The 2-position power connector, AI part #20-033-001, is a removable connector for the fused wires from the fuse panel and contains the female sockets. The wire retaining screws for the fused wire are located on the right side of the connector.

The following illustrates the RDC180-P power connector. It fastens to the power supply with the panel connection screws located on the top and bottom of the connector.

[Figure 8-3](#) displays the side of the connector which plugs into the face of the RDC180-P power supply.

**Figure 8-3: RDC180-P Pin Connector View**

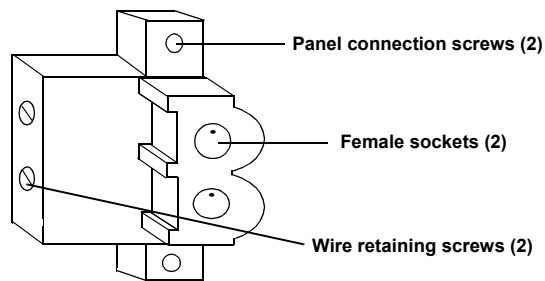

**Figure 8-4: RDC180-P Wire Connector View**

This view displays the side into which the wire connects.

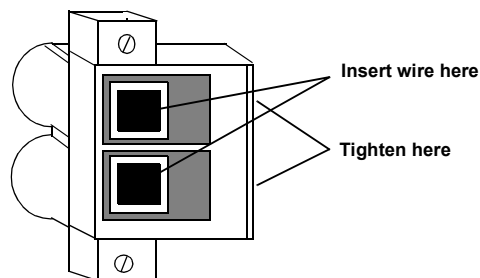

Refer to the [Connecting Fused Power Wires](#) for steps to connect the power to this connector.



## RDC180-P Input Power Wiring

Normal operating conditions are defined as follows: A redundant -48-volt central office power system in which the customer wishes to maintain redundancy.

**Figure 8-5: Single Source Connection for Redundant Power of the RDC180-P**

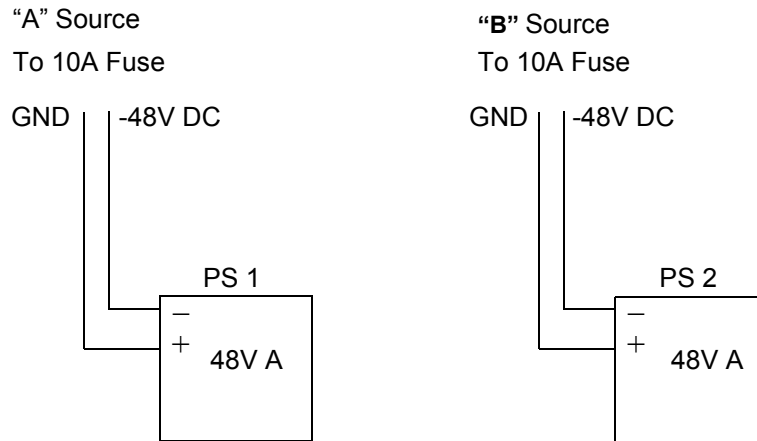

### Single Source Connection

**Note:** +48 VDC refers to the Central Office 48-volt “Return” from the fuse panel.

This figure shows a simple wiring scheme where two drops are made. Each drop is fused at 10 amps.

## Connecting Fused Power Wires

If you have just installed a new power supply or have upgraded to an RDC180-HP, follow these steps to connect the fused power wires. This procedure assumes that a fused power wire has been run to the AISwitch.

1. Confirm that the fuse feeding the power wire that you are going to work on has been removed from the fuse panel.
2. Loosen the power connector mounting screws.
3. Remove the power connector from the power supply.
4. Loosen the wire retaining screws on the side of the power connector.
5. Strip the power lead-in wires about 1/8 inch.
6. Place the stripped end of the wire into the connector. AI recommends that the wire be tinned.



**Caution:** If the plus and minus leads of the connector are shorted together, the fuse in the fuse panel will blow.

7. Tighten the wire retaining screws of the power connector.
8. The solid black wire represents the 48-volt return. The striped black wire represents the -48-volt. The black wires are connected to the “B” side of the fuse panel.

**Note:** Previously, AI used a color-coded wire system to identify the fused power wires. The solid red wire represents the 48-volt return. The striped red wire represents the -48-volt. The red wires are connected to the “A” side of the fuse panel. You may want to tag the wires to identify them.



**Caution:** If the plus and minus leads of the connector are shorted together, the fuse in the fuse panel will blow.

9. Observe the plus and minus on the faceplate of the power supply next to the power connector.
10. Using a voltage meter, check the polarity of each -48 VDC input screw terminal connector.

11. Insert the power connector into the power supply.
12. Tighten the panel connection screws to firmly hold the assembled connector to the power supply.
13. Replace the fuse in the fuse panel.

## Adjusting Voltage

The factory sets the +5 VDC output for both DC power supplies. If you add line cards or replace a power supply, the voltage may drop out of the specified operating range. Applied Innovation Inc. recommends checking the voltage on the AISwitch if you change any hardware. Adjust the voltage if necessary. The +12-volt and -12-volt outputs of the power supplies are not adjustable.

These instructions are for a redundant system. The equipment needed for adjusting the 5-volt potentiometer is:

- Voltmeter
- AI003 voltage test cable (AI Part CAB202)
- Small standard screwdriver

The following steps adjust the +5V power output for the RDC180-P.



**Warning:** If the plus and minus pins of the +5-volt test point connector are shorted together, the AI198 CLC will reset the AISwitch.

**Note:** For most power supplies you adjust the voltage by turning the screw clockwise. However, some power supplies have been produced with different components that require you to turn the screw counter-clockwise.

1. Place a DC volt meter on a flat surface or secure it to the bay.
2. Connect the AI003 voltage test cable to the test meter. (AI Part CAB202).
3. Connect the test cable to the 5-volt test point located on the AI198 CLC.  
The test point is located on the face of the AI198 CLC card beneath the IRB access connector. The CAB202 connector head is keyed for the test point located on the AI198 CLC and can not be inserted incorrectly.
4. Turn OFF only one of the RDC180-P power supplies.
5. Using the 20 VDC scale, check the power supply voltage reading.



**Warning:** Adjusting below five volts may cause the AISwitch to reset.

6. Slowly adjust the +5V ADJ potentiometer on the front of the RDC180-P power supply to obtain the correct reading. The voltage reading should be adjusted to between 5.1 volts and 5.15 volts.
7. Turn ON the unadjusted supply and turn OFF the adjusted supply.
8. Repeat the adjustment for the other RDC180-P.

**Note:** Both power supplies must be within .10V of each other. If they are more than .10V apart, they will not load share.

9. Turn ON the other RDC180-P power supply.
10. Check that the voltage is correct.

# Chapter 9: RDC180-HP Power Supply Revision B

## Overview

The power supply provides power to the AISwitch. It converts incoming -48 volts to +5 volts, -12 volts, and +12 volts for the various cards in the AISwitch.

Use two power supplies to provide redundant power sources for the AI180. If one power supply fails, the AISwitch will utilize the other supply automatically. This process does not affect the operation of the AISwitch. The RDC180-HP also is capable of hot swap operation.

Looking at the cabled side of the AISwitch, the power supplies are located in the upper right section.

**Figure 9-1: DC Power Supply Locations**

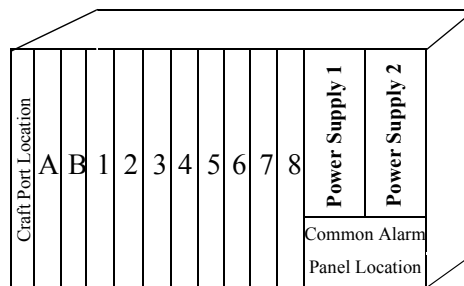

**Note:** Normal operating conditions, when referenced in this document, are defined as follows: A redundant -48-volt Central Office power system in which the customer wishes to maintain redundancy down to and including the RDC180-HP level.

## RDC180-HP Technical Specifications

**Table 9-1: RDC180-HP Technical Specifications**

Specification	Description
Dimensions	Height: 8.0 in. Width: 1.8 in. Depth: 10.8 in.
Weight	5 lbs.
Operating Environment	Temperature: 5°C to 40°C 0% to 90% relative humidity, non-condensing
Input Voltage	<ul style="list-style-type: none"> <li>● -42.5 VDC to -57.5 VDC</li> <li>● Input voltages are isolated from the system frame ground</li> </ul>
Input Current	Maximum 8.5 A at 40 V Maximum 7.1 A at 48 V
Input Power Connectors	Two 2-position power connectors, AI part number 20-033-002.
Output Power Supply Ratings	<ul style="list-style-type: none"> <li>● +5 VDC at 35 A</li> <li>● +12 VDC at 4.0 A</li> <li>● -12 VDC at 4.0 A</li> </ul>
Internal Fusing	One 15-amp fuse, one 10-amp fuse, and two 2-amp fuses which are not replaceable. Refer to the <a href="#">RDC180-HP Internal and External Fuses</a> section for details.

## RDC180-HP Faceplate Description

**Figure 9-2:  
RDC180-HP  
Revision B**

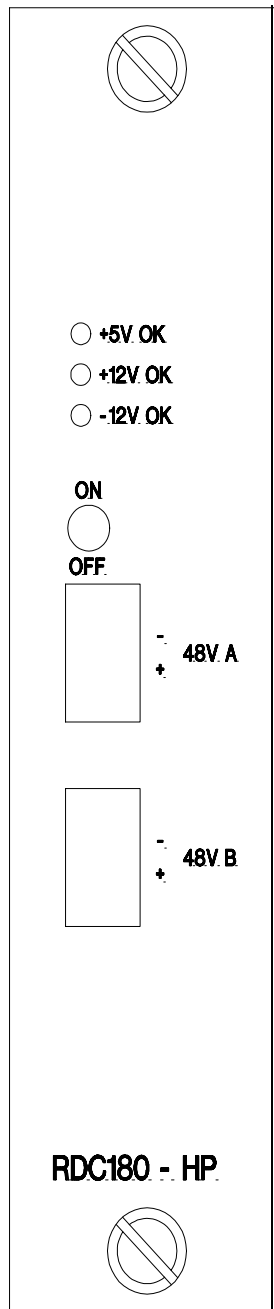

The following is a description of the RDC180-HP Revision B faceplate:

Mounting Screws	These screws, located at the top and bottom of the faceplate, secure the supply in the AISwitch.
+5V OK	This green LED reflects the status of the power supply's output and illuminates when the +5-volt power supply operates correctly.
+12V OK	This green LED reflects the status of the power supply's output and illuminates when the +12-volt power supply operates correctly.
-12V OK	This green LED reflects the output of the power supply and illuminates when the -12-volt power supply operates correctly.
ON/OFF	A toggle switch which turns the power supply on or off. This power switch should be in the up, or ON, position during operation of the AISwitch.
- 48V A & B	These are the 48 VDC power input connectors. Refer to the <a href="#">RDC180-HP Input Power Wiring</a> diagrams.

**Note:** You cannot make external voltage adjustments.

## RDC180-HP Internal and External Fuses

### Internal Fuse

The RDC180-HP uses one 15-amp 125-volt main fuse along with one 10-amp and two 2-amp 125-volt module fuses. The fuses are located near the bottom input power connector and LEDs on the power supply. The fuses are designed to open in the event of a serious power supply malfunction and are not replaceable.

If it appears that a fuse has blown, return the power supply for repair or replacement to AI. Contact Technical Support for specific instructions.

**Figure 9-3: RDC180-HP Fuse Location**

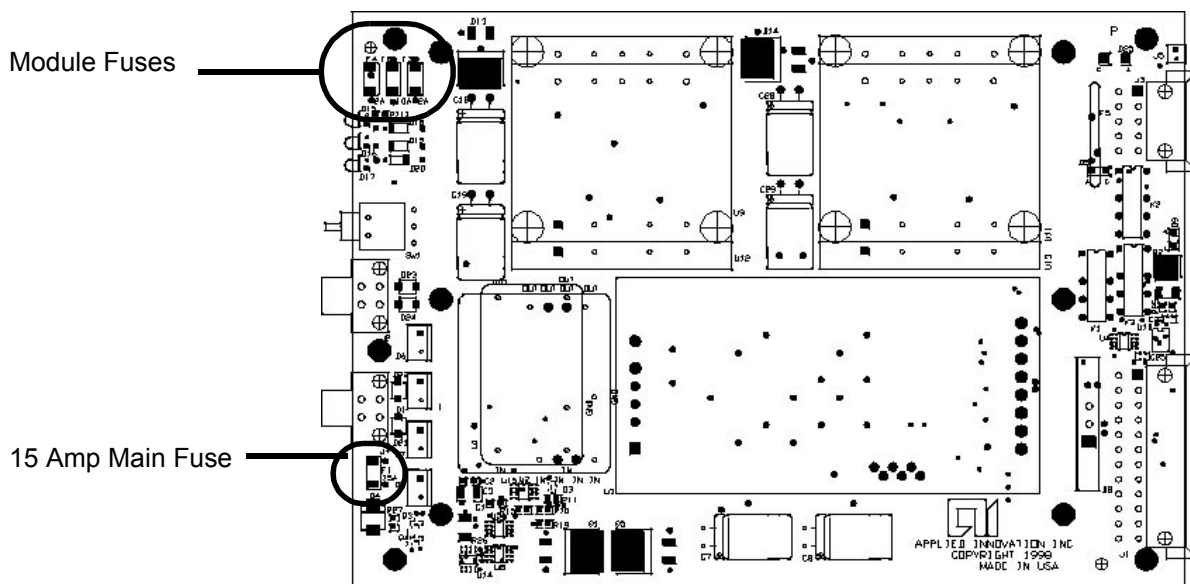

### External Fuse



**Caution:** The 10-amp external fuse, located in the fuse panel, is designed to open in the event of a line surge or a problem with the RDC180-HP supply itself. Using a fuse larger than 10-amps or continually replacing the 10-amp fuse after repeated failures could cause damage to the power supply or one of the system components.

If an external fuse fails and replacing it does not fix the problem, call Technical Support.





## RDC180-HP Power Connectors

There are two identical two position input power connectors on each RDC180-HP. The input connector on the power supply contains the male pins. The two position power connector (AI Part 20-033-002) is a removable connector for the fused wires from the fuse panel and contains the female sockets. The wire retaining screws for the fused wire are located on the right side of the connector. Refer to [Figure 9-6](#) for the specific location.

[Figure 9-5](#) and [Figure 9-6](#) illustrate an RDC180-HP power connector which is fastened to the power supply with the panel connection screws located on the top and bottom of the connector. Each connector can receive a feed from the fuse panel.

### Figure 9-5: RDC180-HP Pin Connector View

This view displays the side of the connector which plugs into the face of the RDC180-HP power supply.

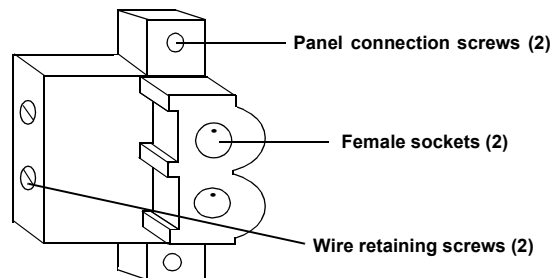

### Figure 9-6: RDC180-HP Wire Connector View

This view displays the side into which the wires connect.

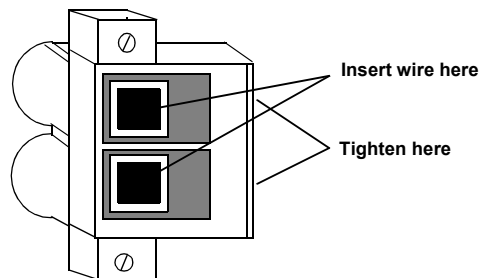

Refer to the [Connecting Fused Power Wires](#) section for steps on how to connect the power to this connector.

## RDC180-HP Input Power Wiring

Normal operating conditions are defined as follows: A redundant -48-volt CO power system in which the customer wishes to maintain redundancy at the RDC180-HP level. These figures represent “normal operation” when redundant CO 48-volt power is available.

[Figure 9-7](#) shows the redundant RDC180-HP power supplies and illustrates which pin locations on the power connector are connected in “normal operation.” Connect the RDC180-HP as directed by the arrows and use the connection diagram in [Figure 9-7](#).

**Figure 9-7: “Normal Operation” Redundant Battery String Connection in a CO**

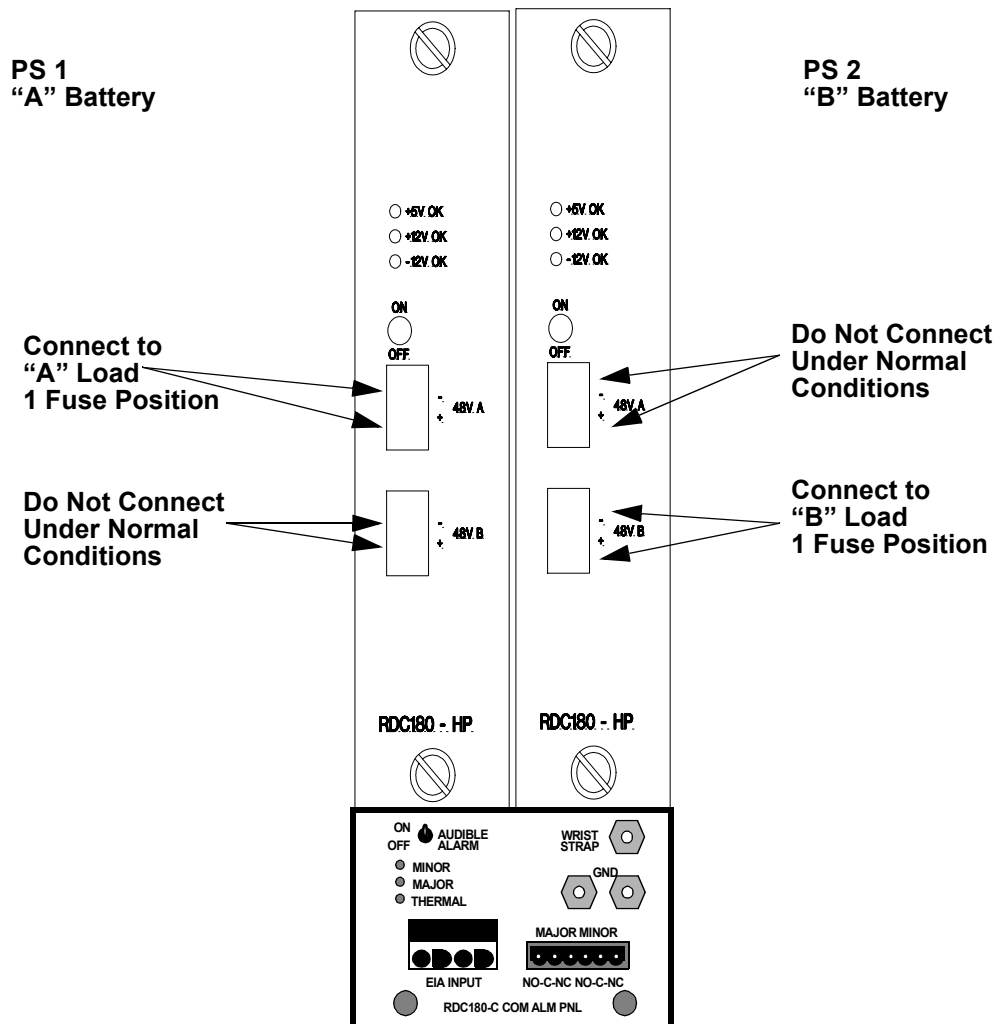

### Normal Redundant Power Supply Connection

[Figure 9-8](#) shows a redundant wiring scheme for power supplies “1” and “2” from the fuse panel. In this scheme, each RDC180-HP is independently supplied power from feed “A” or feed “B,” respectively.

**Note:** The +48 VDC refers to the CO 48-volt “return” from the fuse panel.

**Figure 9-8: Normal Redundant Power Supply Connection**

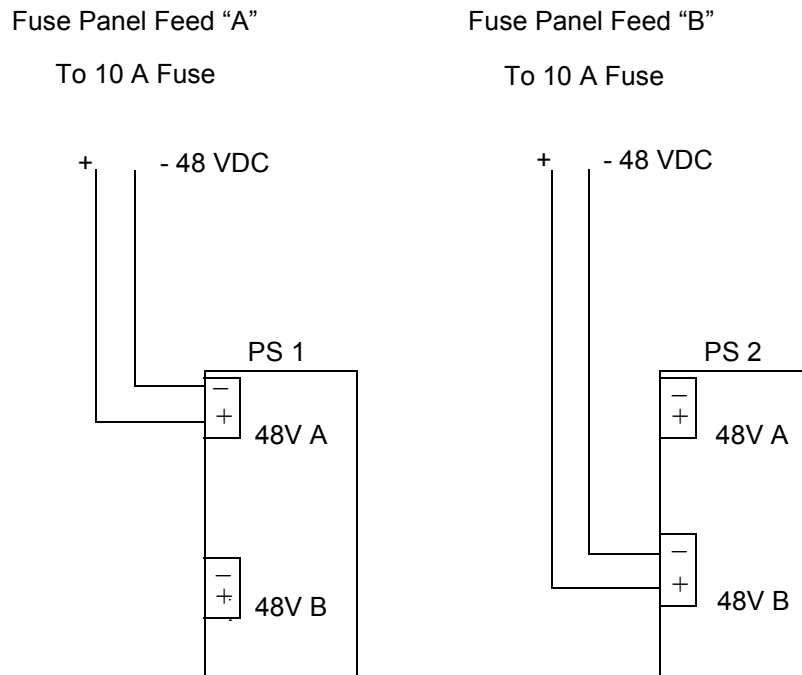

**Double Redundancy Connections Using Four Fuse Panel Positions**

Figure 9-9 shows a fully redundant wiring scheme for power supply “1” and “2.” In this scheme, each RDC180-HP is independently supplied with power from feed “A” and feed “B,” respectively. This allows the AISwitch to receive power if one RDC180-HP fails and one string of the CO power system fails at the same time.

**Note:** +48 VDC refers to the CO 48-volt “return” from the fuse panel.

**Figure 9-9: Double Redundancy Connections Using Four Fuse Panel Positions**

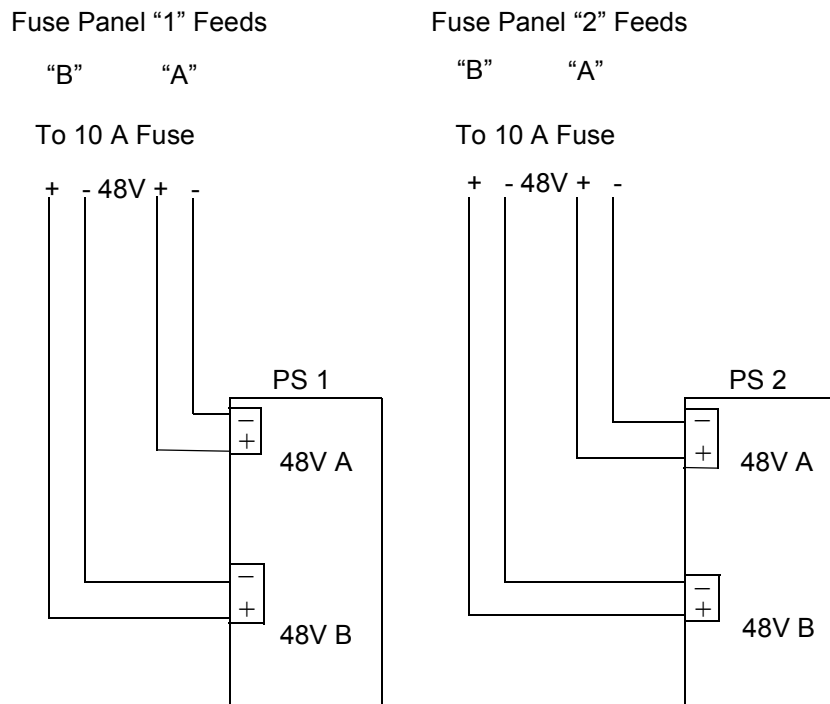

## Replacing a DC Power Supply

This replacement procedure assumes that one power supply is operational while the faulty unit is being replaced, and that the chassis is online.

1. Acquire an appropriate replacement power supply.
2. Turn off the faulty power supply that you are replacing.
3. Remove the fuse supplying -48-volts to the faulty unit from the fuse panel.
4. Remove the input power cabling from the faulty unit.
5. Unscrew the wires from the cable connector which was removed in the previous step.
6. Unscrew cable connectors mounted in the replacement supply.
7. If you are replacing a four-pin Revision A with a two-pin Revision B, move wires from the existing four-pin connector to the two 2-pin connectors. Refer to [Figure 9-10](#) or [Figure 9-11](#).

**Figure 9-10: One 4-Pin Connector to Two 2-Pin Connectors**

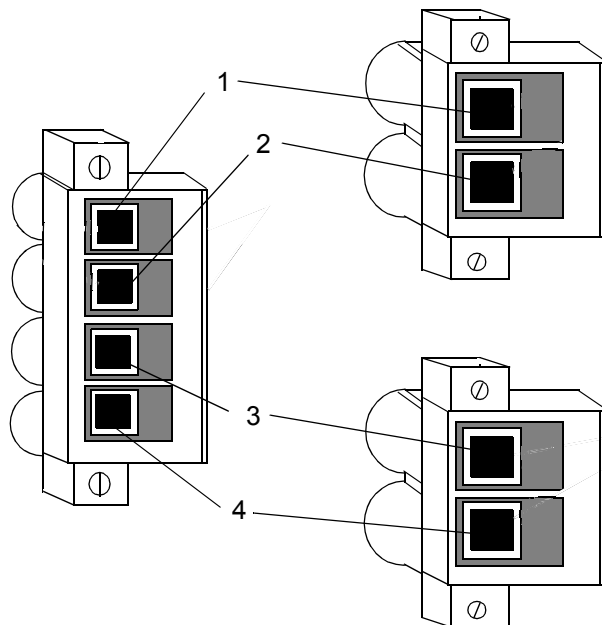
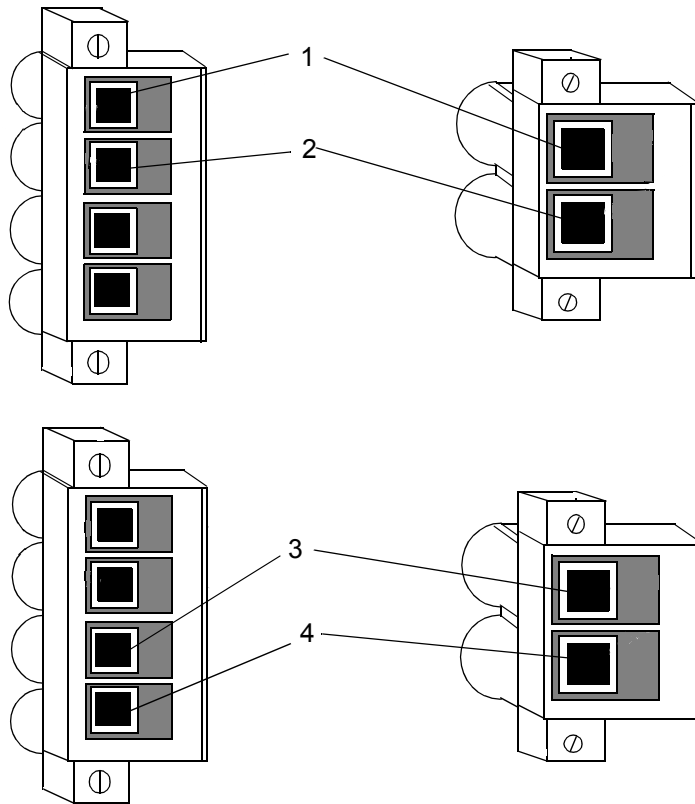

Figure 9-11: Two 4-Pin Connectors to Two 2-Pin Connectors



8. Inspect and repair the cabling as necessary.



**Caution:** Before handling equipment, you must be grounded by the mechanism provided at the installation site.

9. Loosen the mounting screws on the power supply to be replaced until they are fully extended.
10. Pull the power supply forward until it releases from the backplane.
11. Remove the power supply, and place it in an antistatic bag.
12. Check that the new power supply's switch is in the OFF position.
13. Position the power supply so the green LED indicators are at the top.
14. Align and insert the RDC180-HP into the white plastic guide of the power supply slot.
15. Gently slide the power supply into the chassis until it stops at the backplane.

16. Firmly press the faceplate until the faceplate is flush with the front of the AISwitch.
17. Screw in the mounting screws completely to lock the RDC180-HP in place.



**Caution:** A frame ground wire **MUST** be connected to the ground (GND) stud on the common alarm panel **BEFORE** connecting a power supply to a power source.

18. Reconnect the input power cabling.
19. Install the -48-volt fuse back into the fuse panel.
20. Turn on the replacement power supply.



### Installing Fully Redundant DC Power Supplies

If your power supplies are currently connected as fully redundant power supplies as shown in [Figure 9-12](#), you must install two new fuse positions in the fuse panel to achieve full redundancy.

**Figure 9-12: Fully Redundant Revision A Power Supplies**

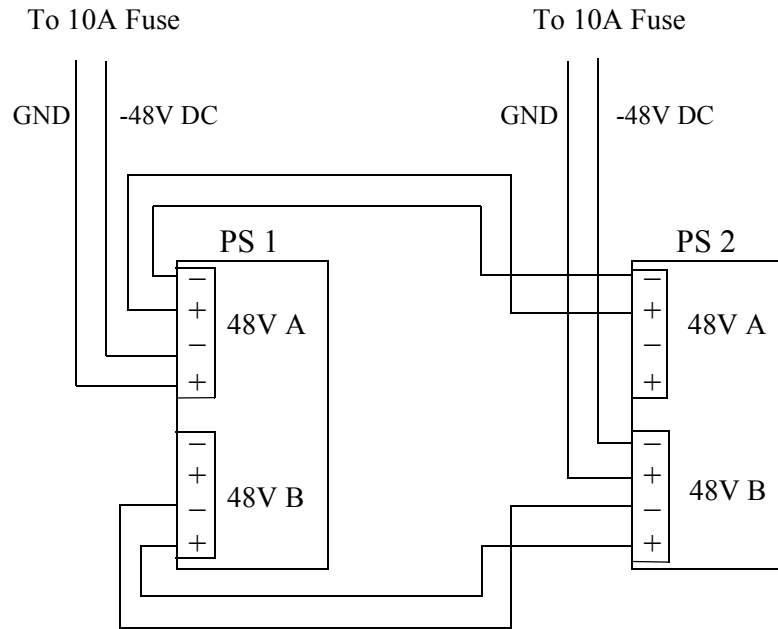

## Installation of Fully Redundant Revision A and Revision B Power Supplies

This replacement procedure assumes that your current power supplies are connected as shown in [Figure 9-12](#). After installation, the chassis will contain one existing Revision A power supply and one replacement Revision B power supply as shown in [Figure 9-13](#).

In the instructions below, the failed Revision A power supply is referred to as the failed supply, the second Revision A power supply in the chassis is referred to as the original supply, and the new Revision B power supply is referred to as the replacement power supply.

1. Turn off the failed power supply.
2. Remove the fuse panel fuse that feeds the failed power supply.
3. Remove the four-pin connector from the failed power supply which is wired to the fuse panel and the original power supply.
4. Remove the two wires from the four-pin connector which are attached to the fuse panel.
5. Remove the two 2-pin connectors from the replacement supply. Insert these wires into one of the two-pin connectors. See [Figure 9-10](#) and [Figure 9-11](#) for attachment diagrams.



**Warning:** The following steps require handling a connector with 48-volts.

6. Remove the second four-pin connector with two wires attached from the failed power supply.
7. Remove the failed power supply.
8. Insert the replacement power supply.
9. Insert the two-pin power cable into the replacement power supply where the cable was originally located.
10. Attach one fuse drop from the fuse panel to the two-pin connector.
11. Insert the remaining two-pin connector into the empty 48-volt input of the replacement power supply.
12. Install the fuses in the fuse panel.
13. Turn on the replacement power supply.
14. Turn off the existing power supply.

15. Remove the fuse in the fuse panel which feeds the original power supply.
16. Remove the four-pin connector with two wires which are attached to the original power supply and discard the connector and wires.
17. Remove the remaining four-pin connector from the original supply.  
Remove and discard the two wires which are attached to the four-pin connector from the failed power supply.
18. Insert the four-pin power cable into the original power supply.
19. Attach one fuse drop from the fuse panel to the four-pin connector at the empty 48-volt input of the original power supply.
20. Replace the fuse in the fuse panel.
21. Turn on the original power supply.

**Figure 9-13: Fully Redundant Revision A and Revision B Power Supplies**

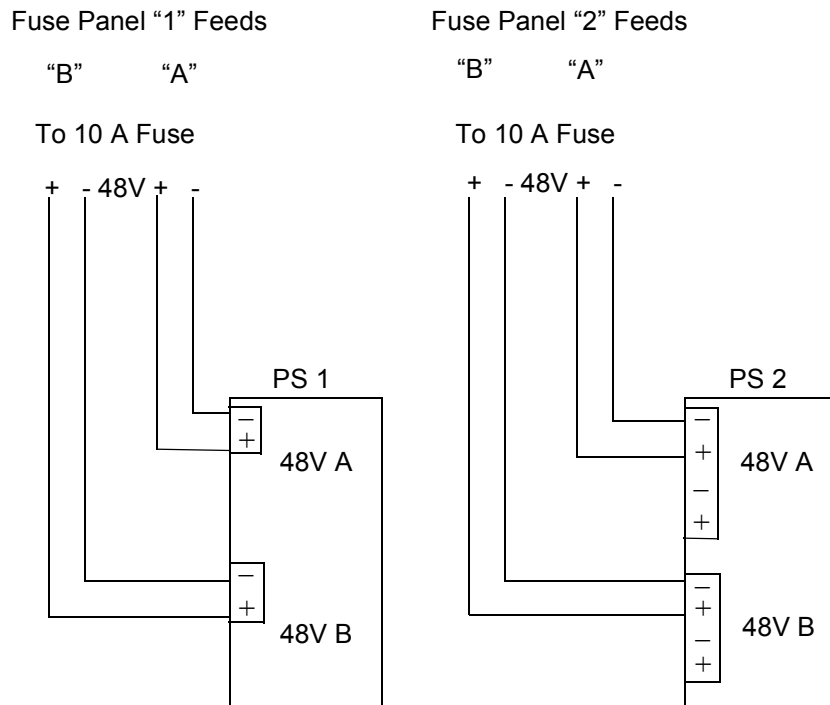

## Installation of Fully Redundant Revision B Power Supplies

Use this procedure to replace or upgrade two fully redundant Revision A power supplies to two fully redundant Revision B power supplies. This replacement procedure assumes that your current power supplies are connected as shown in [Figure 9-12](#). After installation, the chassis will contain two Revision B replacement power supplies as shown in [Figure 9-14](#).

1. Turn off the failed power supply.
2. Remove the fuse panel fuse that feeds the failed power supply.
3. Remove the four-pin connector from the failed power supply which is wired to the fuse panel and the operational power supply.
4. Remove the two wires from the four-pin connector which are attached to the fuse panel.
5. Remove the two 2-pin connectors from the replacement supply. Insert these wires into one of the two-pin connectors on the replacement power supply. See [Figure 9-10](#) and [Figure 9-11](#) for attachment diagrams.



**Warning:** The following steps require handling a connector with 48-volts.

6. Remove the second four-pin connector with two wires attached from the failed power supply.
7. Remove the failed power supply.
8. Insert the replacement power supply.
9. Insert the two-pin power cable into the replacement power supply where the cable was originally located.
10. Attach one fuse drop from the fuse panel to the two-pin connector.
11. Insert the remaining two-pin connector into the empty 48-volt input of the replacement power supply.
12. Install the fuses in the fuse panel.
13. Turn on the replacement power supply.
14. Turn off the second failed power supply.
15. Remove the fuse in the fuse panel which feeds the second failed power supply.
16. Remove the four-pin connector with two wires which are attached to the second failed power supply and discard the connector and wires.

17. Remove the remaining four-pin connector from the second failed power supply.  
Remove and discard the two wires which are attached to the four-pin connector from the failed power supply.
18. Remove the two wires from the four-pin connector and insert these two wires into the two-pin connector of the second replacement power supply. See [Figure 9-11](#) for the attachment diagram.
19. Attach one fuse drop from the fuse panel to the remaining two-pin connector.
20. Remove the second failed power supply.
21. Install the second replacement power supply.
22. Insert both two-pin power cables into the second replacement power supply.
23. Install the fuses in the fuse panel.
24. Turn on the second replacement power supply.

**Figure 9-14: Two Fully Redundant Revision B Power Supplies**

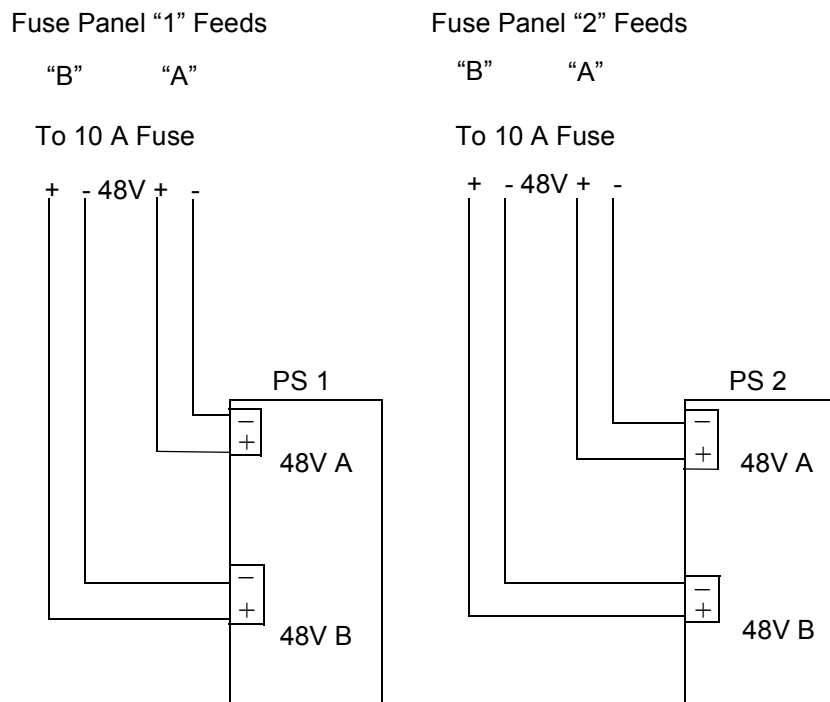

## Connecting Fused Power Wires

If you have just installed a new power supply or have upgraded to an RDC180-HP, follow these steps to connect the fused power wires. This procedure assumes that a fused power wire has been run to the AISwitch.

1. Confirm that the fuse feeding the power wire that you are going to work on has been removed from the fuse panel.
2. Loosen the power connector mounting screws.
3. Remove the power connector from the power supply.
4. Loosen the wire retaining screws on the side of the power connector.
5. Strip the power lead-in wires about 1/8 inch.
6. Place the stripped end of the wire into the connector. AI recommends that the wire be tinned.



**Caution:** If the plus and minus leads of the connector are shorted together, the fuse in the fuse panel will blow.

7. Tighten the wire retaining screws of the power connector.
8. The solid black wire represents the 48-volt return. The striped black wire represents the -48-volt. The black wires are connected to the “B” side of the fuse panel.

**Note:** Previously, AI used a color-coded wire system to identify the fused power wires. The solid red wire represents the 48-volt return. The striped red wire represents the -48-volt. The red wires are connected to the “A” side of the fuse panel. You may want to tag the wires to identify them.



**Caution:** If the plus and minus leads of the connector are shorted together, the fuse in the fuse panel will blow.

9. Observe the plus and minus on the faceplate of the power supply next to the power connector.
10. Using a voltage meter, check the polarity of each -48 VDC input screw terminal connector.

11. Insert the power connector into the power supply.
12. Tighten the panel connection screws to firmly hold the assembled connector to the power supply.
13. Replace the fuse in the fuse panel.





# Chapter 10: AI325-AC Power Supply

## Overview

One AC power supply is available for the AISwitch Series 180 chassis. The AI325-AC power supply provides a non-redundant AC power source for the AI180. The AC power supply should be used where an external AC/DC converter is not feasible to install.

Applied Innovation recommends using the RDC180-HP power supply for all applications. In situations where DC power is not available, then external AC/DC converters are recommended.



**Caution:** Before beginning the installation of any AI component, the operator and equipment must be grounded by the mechanism used at the installation site. Refer to the [Static Electricity \(ESD\)](#) component for more details about the grounding process.

The AI325-AC power supply uses a plug-in connector for easy installation. It is mounted vertically in the chassis occupying both power supply slots above the common alarm panel. The two-fan RDC180-C Alarm Panel is required for the AI180 equipped with the AI325-AC power supply.

**Figure 10-1: AI180 AC Power Supply Location**

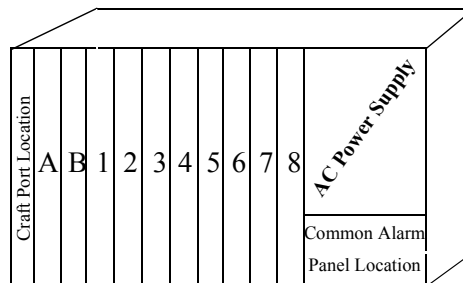

**Caution:** An Applied Innovation RDC180-C Alarm Panel two-fan unit must be installed in the chassis prior to installation of the AI325-AC Power Supply.

**AI325-AC  
Technical  
Specifications**

The table below lists the specifications of the AI325-AC power supply.

**Table 10-1: AI325-AC Technical Specifications**

Specification	Description
Dimensions	Height: 8 in. Width: 3.6 in. Depth: 9.5 in.
Weight	Approximately 5.0 lbs.
Operating Environment	0 °C -50 °C 0-95% relative humidity, non-condensing
Input Power Ratings	Unit shuts down when the input drops below 63 V or rises above 283 V.  <ul style="list-style-type: none"> <li>● AC input voltage between 102 VAC- 264 VAC</li> <li>● 47 - 63 Hz, auto ranging</li> <li>● 7.0 A max at 102 VAC</li> </ul> The unit automatically recovers when the voltage is corrected. Reverse voltage protected up to the rated current.
Power Factor	0.60 typical
In Rush Current	50 A max. at cold start-up
Holdup Time	20 msec. at full load and low line
Line and Load Regulation	0.1% max. over AC input range and 0-100% load
Transient Response	Voltage returns to specification in less than 300 microseconds for a 50% load change. Peak transient voltage does not exceed 10%.
Overshoot	No output overshoot at turn-on or turn-off

<b>Specification (Continued)</b>	<b>Description (Continued)</b>
Input Power Connector	One AC line cord (US or European). The AC power cord is plugged into the power supply directly below the power switch. The power cord retainer clip is in place around the power cord as shown in the <a href="#">AI325-AC Faceplate</a> illustration.
Output Power Supply Ratings	The AI325-AC power supply provides the AISwitch system with three output voltages: <ul style="list-style-type: none"> <li>● +5 VDC +/- 1%, 40 A max.</li> <li>● +12 VDC +/- 1%, 6.25 A max.</li> <li>● -12 VDC +/- 1%, 4.0 A max.</li> </ul> (325W total power non-redundant) Voltage measured at the power supply backplane connector.
Ratings	UL, CSA, TUV Safety certified to UL 1950, CSA 950, and IEC 950 Class 1 SELV
Connections to Backplane	Molex 15-24-9104 Molex 15-24-9244
Adjustment	Externally accessible +5 V adjustment located on the front panel single- turn trimpot. See the <a href="#">Voltage Adjustment Procedure</a> section for more details.

## AI325-AC Panel Faceplate

Refer to the [RDC180-C Common Alarm Panel](#) component for a detailed explanation of the common alarm panel components.

Figure 10-2: AI325-AC Faceplate

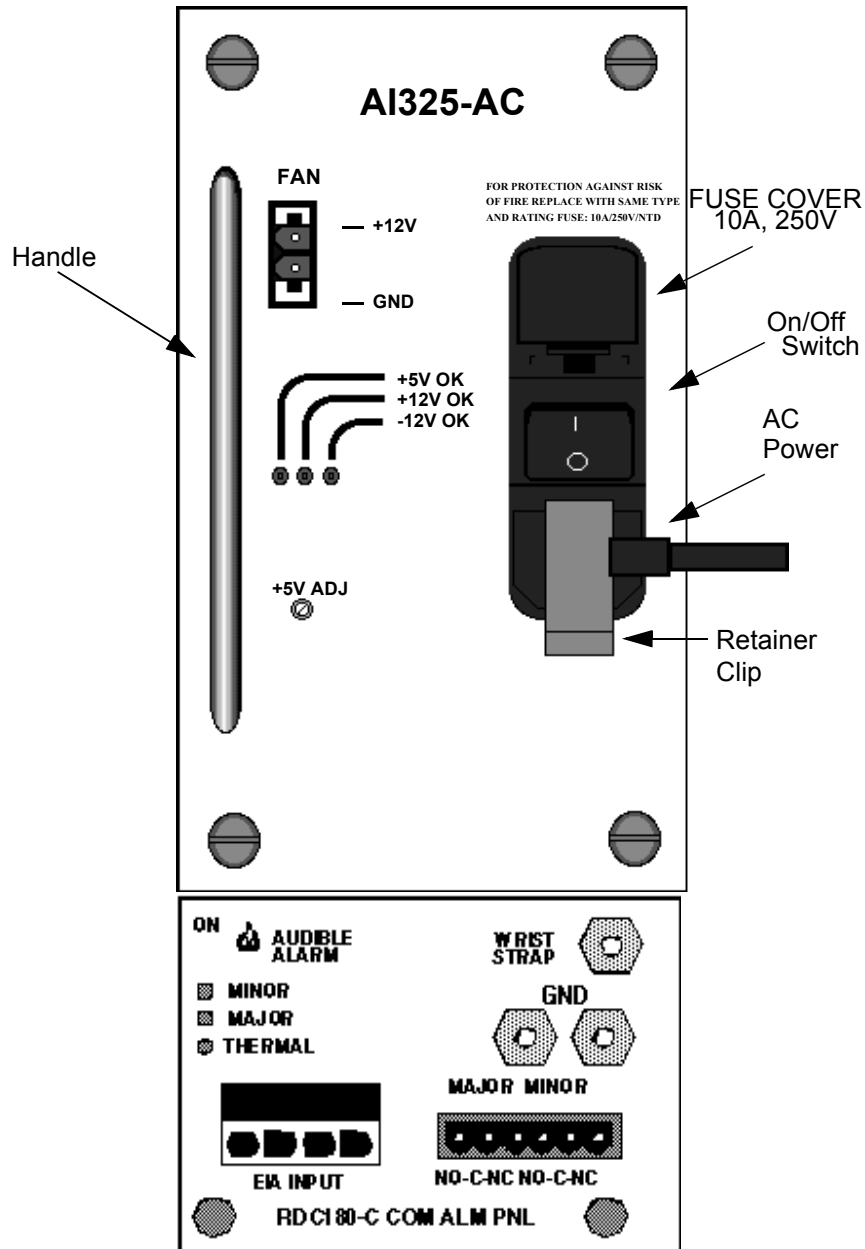

## AI325-AC Faceplate Description

The AI325-AC unit installs vertically in the slots of the AI180 as shown in the [AI180 AC Power Supply Location](#) figure.

The following describes the components of the AI325-AC faceplate:

FAN +12 V GND	Proprietary connector for AI use only.
+5 V OK	<ul style="list-style-type: none"> <li>● Green LED reflecting the output of the power converter. This LED illuminates when the power converter is connected to the +5-volt supply.</li> <li>● If the indicator is dark, there may be a problem with the +48-volt power source or the AI325-AC power converter, or the +5-volt may not be properly adjusted.</li> </ul>
+12 V OK	<ul style="list-style-type: none"> <li>● Green LED reflecting the output of the power converter. This LED illuminates when the power converter is connected to the +12-volt supply.</li> <li>● If the indicator is dark, there is a problem with the power source or the power converter.</li> </ul>
-12 V OK	<ul style="list-style-type: none"> <li>● Green LED reflecting the output of the power converter. This LED illuminates when the power converter is connected to the -12-volt supply.</li> <li>● If the indicator is dark, there is a problem with the power source or the power converter.</li> </ul>
+5 V ADJ	Adjustment slot for the +5 VDC output. Adjusts the +5-volt between +5.1-volt and +5.2-volt.
FUSED 10 A, 250 V	The location of the two 10 amp fuses.
 0	This is the power switch for this module. Up is on, down is off. The switch must be in the ON position during AISwitch operation.

## Input Power Connectors

### AI325-AC Power Cord

One input power cord is supplied with each AI325-AC power supply.

## Voltage Adjustment Procedure

The +12 V and -12 V outputs of the AI325-AC power supply are fixed and cannot be adjusted. The factory sets the output voltage when the system is manufactured.

The +5 VDC output for the AC power supply is set at the factory during initial configuration. The power supply may need adjustment when replacing the power supply or when adding additional cards to the chassis. The equipment needed for adjusting the 5 V potentiometer is:

- Voltmeter
- Voltage test cable (AI Part CAB202)
- Small standard screwdriver



**Caution:** If using a test probe and the + and - pins of the +5 V test point connector are shorted together, the AI198 will reset the AISwitch.

The following steps adjust the +5 volt power output for the AI325-AC power supply.

1. Keep the AI325-AC turned on.
2. Place a DC voltmeter on a flat surface or secure it to the bay.
3. Connect the CAB202 voltage test cable to the test meter.
4. Connect the test cable to the +5-volt test point located on the AI198 CLC.  
The test point is located on the face of the AI198 CLC card beneath the RJ45 connector.  
The CAB202 connector head is keyed for the test point located on the AI198 CLC and can not be inserted incorrectly.
5. Using the 20 VDC scale, check the power supply voltage reading.
6. Carefully adjust the +5 volt ADJ potentiometer on the front of the AI325-AC power supply to obtain the correct reading. The voltage reading can be adjusted to between 5.1 volt and 5.2 volt.



**Caution:** Adjustment of the voltage below 5.1 volts may reset the AISwitch.

7. Disconnect and properly store the CAB202 and voltmeter.

## **Adding Cards to an AI325-AC System**

When additional line cards are added to a system using the AI325-AC power supply, the voltage should be adjusted to compensate for the voltage drop that occurs from the extra current being drawn. These changes will be small for each SLC added, but it is recommend that the voltage is checked whenever changes to the system are made.

Follow the steps in the [Voltage Adjustment Procedure](#) to check the AI325-AC power supply.

## Power Supply Fuses

### AI325-AC Fuses

Two 10 amp fuses provide current protection for the AI325-AC power supply.

Refer to the [AI325-AC Faceplate Description](#) section for the location of the fuse holding.

### How to Replace the 10 Amp Fuses

Follow these steps to replace the two 10 amp fuses in the AI325-AC.

1. Make sure the On/Off switch on the power supply is in the OFF position.
2. Using a small flat head screwdriver, lift the tab at the bottom of the fuse housing and release the fuse holder cover.
3. Determine which fuse is necessary to replace.
4. Replace the fuse in the fuse holder.
5. Reinsert the fuse holder into the fuse housing.
6. Press the cover until the fuse holder locks into position.

## Jumper Settings

Located on the back of the AI325-AC, the J5 header is a two-pin header used exclusively by the manufacturing department at Applied Innovation. In the field, a jumper should never be placed across these two pins.



## Installing/ Replacing an AI325-AC Power Supply

Follow these steps to install/replace an AI325-AC power supply.

1. Use appropriate grounding as required by the telecommunication facility. Refer to the [Static Electricity \(ESD\)](#) component for more details about the grounding process.
2. Remove the new power supply from the shipping container and check for damage.
3. If replacing the unit, turn the power supply off and unplug the power cord from the inservice AC power source.
4. If replacing the AI325-AC, remove the existing power supply from the system enclosure by unscrewing the four retaining screws and pulling on the handle.
5. Locate the two slots directly above the common alarm panel.
6. Position the new power supply so that the metal rail on the bottom left of the supply aligns with the left most white plastic guide.
7. Gently slide the power supply into the system enclosure until it stops at the backplane.
8. Firmly press the faceplate until the faceplate is flush with the chassis.  
The power supply should not release when you gently tug on the panel handle.
9. Screw in the extended retaining screws to lock the power supply in place.



**Caution:** A frame ground wire **MUST** be connected to the ground (GND) studs on the common alarm panel **BEFORE** connecting the power cord to an AC power source.

10. Plug the power cord into the AC power source.
11. Turn the power supply ON (|) by depressing the top portion of the ON/OFF switch.
12. Check the +5 volt, +12 volt, and -12 volt indicators on the power supply for three green lights.
13. Connect a DC multimeter to the +5 GND outlet of the AI198 or AI199 CLC. Refer to the AI325AC [Voltage Adjustment Procedure](#).
14. Slowly adjust the power supply +5 volt ADJ setting until the multimeter indicates 5.1 volt. The installation is now complete.

## Upgrading to an AI325-AC Power Supply

The AI325-AC Power Supply may be used to replace an older AC power supply which did not allow use of the Common Alarm Panel.

Equipment needed:

- AI325AC power supply
  - A two-fan AI RDC180-C
  - Medium phillips screw driver
  - Allen wrench
  - Small crescent wrench or nut driver set
1. Use appropriate grounding as required by the telecommunication facility. Refer to the Static Electricity (ESD) component for more details about the grounding process.
  2. Remove the new power supply from the shipping container and check for damage.
  3. Turn off and unplug the power cord of the inservice unit from the AC power source.
  4. Remove the ground wire (GND) nut and disconnect the ground cable using the crescent type wrench or appropriate nut driver.
  5. Remove the existing power supply from the system enclosure by unscrewing the retaining screws, gripping the screw ground, and pulling the power supply from the unit.
  6. Install the RDC180-C Common Alarm Panel by plugging in the ribbon cable into the lower right corner of the backplane.
  7. Screw in the two screws provided in the lower portion of the common alarm panel.  
  
Confirm that the ribbon cable is still inserted in the backplane.
  8. Insert the top guide rail in the top right corner of the chassis and screw in the two screws provided.
  9. Locate the two slots directly above the Common Alarm Panel.
  10. Position the power supply so that the metal rail on the bottom of the supply aligns with the left most white plastic guide.
  11. Gently slide the power supply into the system enclosure until it stops at the backplane and is flush with the chassis.
  12. Firmly press the faceplate into position.

The module should not release when you gently tug on the panel handle.

13. Tighten the extended retaining screws to lock the power supply in place.



**Caution:** A frame ground wire **MUST** be connected to the ground (GND) studs on the common alarm panel **BEFORE** connecting the power cord to an AC power source.

14. Connect the right angle power cable supplied with the AI325-AC power supply to the On/Off switch fuse housing.
15. Connect the ground cable to the ground (GND) studs on the RDC180-C Common Alarm Panel.
16. Plug the power cord in to the AC power source.
17. Turn the power supply ON (|).
18. Check the +5 volt, +12 volt, and -12 volt indicators on the power supply for three green lights.
19. Connect a DC multimeter to the +5 GND outlet of the CLC. Refer to the [Voltage Adjustment Procedure](#).
20. Slowly adjust the power supply +5 volt ADJ setting until the multimeter indicates 5.1 volt. The installation is now complete.

## Testing the Unit

1. Insert the AI325-AC unit. See the [Installing/ Replacing an AI325-AC Power Supply](#) section.
2. Plug in the AI325-AC power cord.
3. Verify the illumination of the following three indicators: +5 V OK, +12 V OK, -12 V OK.

# Chapter 11: RDC180-C Common Alarm Panel

## Overview

The RDC180-C Common Alarm Panel provides an external alarm interface for the AISwitch. It includes the following alarm indicators for the power converters: major, minor, and thermal. The alarm panel also indicates AISwitch software alarm conditions if the system manager configures the software accordingly.

Looking at the cabled side of an AI180, the common alarm panel is on the right side, below the power converters.

## RDC180-C Common Alarm Panel Description

The following illustration shows the faceplate panel and connectors for the RDC180-C Common Alarm Panel.

**Figure 11-1: RDC180-C Common Alarm Panel**

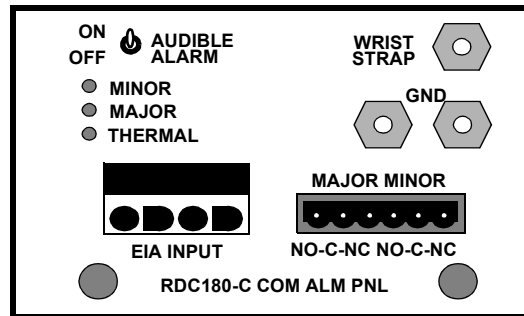

The following describes the components of the RDC180-C faceplate:

AUDIBLE ALARM	Toggle switch that turns the audible alarm on or off.
WRIST STRAP	Connect your anti-static wrist strap here.
MINOR	This red LED lights when there is a minor alarm.
MAJOR	This red LED lights when there is a major alarm.
THERMAL	This red LED lights when there is a thermal alarm. This occurs when the temperature in the chassis exceeds +55° C.
GROUND	The ground studs provide grounding for all of the AISwitch chassis.
EIA INPUT	The connection point for the “Y” cable (CABL121) that connects the alarm panel to Port 0 on the AISwitch for software alarms. This is for systems that use an AI181 CLC.
MAJOR MINOR	These alarm relays terminate on this connector block. A six-wire cage-clamp connector is inserted into this mounted header. Note that the three pins on the left are for MAJOR alarms while the three on the right are for MINOR alarms.
NC	The NC pin is normally closed; in contact with the C pin.
C	C is the common contact pin of the relay.
NO	The NO pin is normally open; not in contact with the C pin.

## Connections

### Input Connections

If you are using the alarm panel only to indicate power converter alarm conditions, you do not need input connections.

### Output Connections

The major and minor alarm relays terminate on the alarm panel modular connector.

A six-wire cage-clamp connector connects to the relay. The three connectors on the left are for the major alarms while the three on the right are for the minor alarms. The normal condition is when no alarms are present. The connections are such that:

- The C designation is for the common contact pin for each relay.
- The NC connection is normally closed or in contact with the C pin.
- The NO connection is normally open or not in contact with the C pin.

### Grounding

The RDC180-C includes a ground bolt. You must connect the ground bolt to a suitable ground, such as the frame ground of the rack system or a reliable earth ground point. This ground bolt provides grounding for the AISwitch chassis.

### Wrist Strap

The panel has a plug-in connection for an anti-static wrist strap.

## Alarm Indicators

The RDC180-C uses three red LEDs to indicate minor, major, and thermal alarms. If an alarm occurs, one or more red LEDs will illuminate. If you set the audible alarm switch to ON, then an audible alarm will sound when there is an major alarm.

The alarm LEDs indicate that an alarm condition exists. However, since these alarm LEDs use +5 VDC power, some conditions will prevent them from illuminating even though an alarm condition exists. Illuminated alarm LEDs do not halt AISwitch operations.

The following table describes the alarms issued at the external alarm connector when you have two power converters (redundant configuration).

**Table 11-1: Alarm Description for Redundant Configuration**

Major	Minor	Event
Yes	No	Thermal overload (temperature within the chassis exceeds +55° C).
No	Yes	Failure of a single +5 VDC.
No	Yes	Failure of a single +12 VDC.
No	Yes	Failure of a single -12 VDC.
Yes	Yes	Failure of both +5 VDC.
Yes	Yes	Failure of both +12 VDC.
Yes	Yes	Failure of both -12 VDC.
No	Yes	Failure of one battery input.
Yes	Yes	Failure of both battery inputs.
Yes	Yes	Unit turned off.

The following table describes what alarms the red LEDs on the RDC180-C indicate when you have one power converter (non-redundant configuration).

**Table 11-2: LED Description for Redundant Configuration**

Major	Minor	Event
On	Off	Thermal overload (temperature within the chassis exceeds +55° C). The red THERMAL LED will also be illuminated.
Off	On	Failure of a single +5 VDC.
Off	On	Failure of a single +12 VDC.



<b>Major</b>	<b>Minor</b>	<b>Event</b>
Off	On	Failure of a single -12 VDC.
Off	Off	Failure of both +5 VDC.
On	On	Failure of both +12 VDC.
On	On	Failure of both -12 VDC.
Off	On	Failure of one battery input.
Off	Off	Failure of both battery inputs or unit turned off.

The following table describes what alarms the red LEDs on the RDC180-C indicate when you have one power converter (non-redundant configuration).

**Table 11-3: LED Description for Non-Redundant Configuration**

<b>Major</b>	<b>Minor</b>	<b>Event</b>
On	Off	Thermal overload (temperature within the chassis exceeds +55° C). The red THERMAL LED illuminates.
Off	Off	Failure of +5 VDC.
On	On	Failure of +12 VDC.
On	On	Failure of -12 VDC.
Off	Off	Failure of battery input.
Off	Off	Unit turned off.

## Software-Related Alarms

System managers set the alarm notification conditions when they configure the CLC. Refer to the *AI198 System Manager/User's Manual* for a list of CLC alarm levels and messages. For a list of Smart Line Card (SLC) alarms, refer to the appropriate SLC user's manual.

### Installing an RDC180-C Common Alarm Panel

**Note:** You must install the RDC180-C before installing the power supplies.



**Warning:** Before handling equipment, you must be grounded by the mechanism provided at the installation site. Refer to the Static Electricity (ESD) component for more details.

1. Unpack the RDC180-C and check for shipping damage.
2. On the cabled side of the AISwitch chassis, locate the alarm panel and power converter opening.
3. Position the bracket adapter at the top of the opening. The white plastic guide rails should be on the bottom of the bracket, the face plate in front of the top mounting rail and the two holes aligned with the two holes in the rail.
4. Using a 1/8-inch Allen wrench, screw in the hex head mounting screws and locking washers until the bracket is firmly attached to the system enclosure.
5. Find the ribbon cable you received with the alarm panel. Holding the cable with the red stripe on top so that the connectors point out away from you, locate the connector with the cable coming out on the right side. See the figure below.

**Figure 11-2: Ribbon Cable**

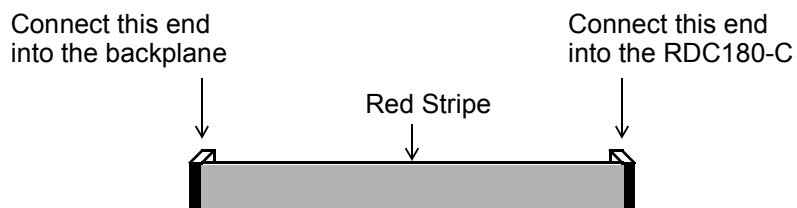

6. Carefully plug the connector into the matching connector on the backplane (see [Figure 11-2](#)). This is a keyed connector, so the key on the cable aligns with the slot on the connector in the backplane.
7. Position the cable along the right side of the AISwitch chassis.
8. Insert the alarm panel halfway into the opening. The ribbon cable should be on the right side of the alarm panel.
9. Plug the other end of the ribbon cable, red stripe on top, into the matching cable connector on the back side of the faceplate on the PC board.
10. Push in the alarm panel until the faceplate is smooth with the chassis.
11. Attach a ground strap between the ground bolts and an appropriate ground.
12. If appropriate, make the EIA cable (CABL121) and alarm connections, which require the provided cage-clamp connectors.

## Replacing an RDC180-C Common Alarm Panel



**Warning:** Before handling equipment, you must be grounded by the mechanism provided at the installation site. Refer to the Static Electricity (ESD) component for more details.

1. Unpack the new RDC180-C and check for shipping damage.
2. On the cabled side of the AISwitch chassis, locate the alarm panel and power converter opening.
3. Remove the power supply.
4. Remove the ground strap.
5. Using a 1/8-inch Allen wrench, remove the hex head mounting screws holding the alarm unit.
6. Remove the RDC180-C.
7. Detach the ribbon cable from the backplane.
8. Find the ribbon cable you received with the alarm panel. Holding the cable with the red stripe on top so that the connectors point out away from you, locate the connector with the cable coming out on the right side. See the figure below.

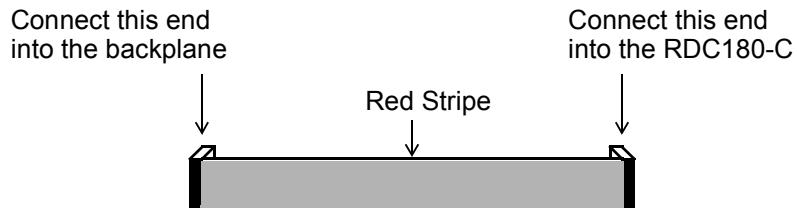
**Figure 11-3: Ribbon Cable**

9. Carefully plug the connector into the matching connector on the backplane (see [Figure 11-3](#)). This is a keyed connector, so the key on the cable aligns with the slot on the connector in the backplane.
10. Position the cable along the right side of the AISwitch chassis.
11. Insert the alarm panel halfway into the opening. The ribbon cable should be on the right side of the alarm panel.
12. Plug the other end ribbon cable, red stripe on top, into the matching cable connector on the back side of the faceplate and PC board to the right.
13. Push in the alarm panel until the faceplate is smooth with the chassis.
14. Using a 1/8-inch Allen wrench, screw in the hex head mounting screws and lock washers until the alarm panel is firmly attached to the system enclosure.
15. Replace the power supply.
16. Attach a ground strap between the ground bolts and an appropriate ground.
17. If appropriate, make the EIA cable (CABL121) and alarm connections, which require the provided cage-clamp connectors.

# **Chapter 12: RDC130-C Common Alarm Panel**

## **Overview**

The RDC130-C Common Alarm Panel provides an external alarm interface for the AISwitch Series 130. It includes the following alarm indicators: major, minor, and thermal.

## RDC130-C Common Alarm Panel Description

**Figure 12-1:  
RDC130-C  
Faceplate**

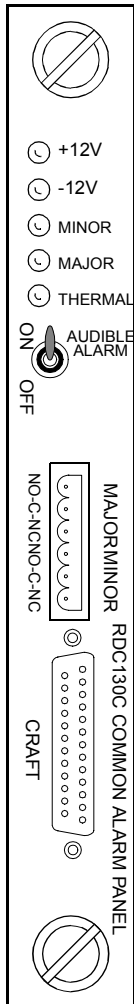

The following describes the RDC130-C Faceplate:

- +12V**                    A green LED indicates +12 V when power is on.
- 12V**                    A green LED indicates -12 V when power is on.
- MINOR**                    A red LED indicates a minor alarm when power is on. During normal operation this LED should be off.
- MAJOR**                    A red LED indicates a major alarm when power is on. During normal operation this LED should be off.
- THERMAL**                    A red LED indicates a thermal alarm when power is on. This LED goes on if the temperature exceeds approximately +55 °C. During normal operation this LED should be off.
- AUDIBLE ALARM ON/OFF**                    Enable the audible alarm by moving the toggle switch to the ON position. When ON, the audible alarm will sound if there is a major alarm.
- MAJOR    MINOR**                    The MAJOR and MINOR alarm relays terminate on this connector block. Insert a six-wire screw terminal connector (Part# 20-033-003) into the mounted header. When wiring the connector, note that the three connectors on the left are for MAJOR alarms while the three on the right are for MINOR alarms.
- NC**                                    The NC connection is normally closed, contacting the C pin. The connection is open or disconnected from the C pin when there is an alarm.
- C**                                        C is the common contact pin of the relay.
- NO**                                    The NO connection is normally open, not contacting the C pin. The connection is closed or connected to the C pin when there is an alarm.
- CRAFT**                                The craft port is an RS232 interface used for configuration and diagnostic output from the AI198-CLC.

## Connections

### Output Connections

The major and minor alarm relays terminate on the alarm panel modular connector.

A six-wire screw terminal connector (AI Part 20-033-003) connects to the relays. The three connectors on the left are for the major alarms while the three on the right are for the minor alarms. The normal condition is when no alarms are present. The connections are such that:

- The C designation is for the common contact pin for each relay.
- The NC connection is normally closed, contacting the C pin. The connection is open or disconnected from the C pin when there is an alarm.
- The NO connection is normally open, not contacting the C pin. The connection is closed or connected to the C pin when there is an alarm.

## RDC130-C Alarm Indicators

The RDC130-C uses three red LEDs to indicate minor, major, and thermal alarms, and relay contact closures to indicate major and minor alarms. An alarm does not halt AISwitch operations. Indicators alert the user that an alarm condition exists. If an alarm occurs, one or more red LEDs will be illuminated and relays activated. However, the LEDs will not illuminate under some alarm conditions if the +5 VDC supply fails. If you switch ON the AUDIBLE ALARM, an audible alarm will sound during a major alarm.

The system has a thermal sensor that triggers the THERMAL alarm if the internal temperature exceeds approximately +55 degrees Celsius. This alarm condition does not halt the AISwitch.

**Table 12-1: Alarm Description for Redundant Configuration**

Major	Minor	Event
On	Off	Thermal overload (temperature within the chassis exceeds approximately +55°C). The THERMAL LED will illuminate.
Off	On	Failure of a single +5 VDC.
Off	On	Failure of a single +12 VDC.
Off	On	Failure of a single -12 VDC.
Off	Off	Failure of both +5 VDC.
On	On	Failure of both +12 VDC.
On	On	Failure of both -12 VDC.
Off	On	Failure of one battery input.
Off	Off	Failure of both battery inputs or unit turned off.



**Table 12-2: Alarm Description for Non-Redundant Configuration**

<b>Major</b>	<b>Minor</b>	<b>Event</b>
On	Off	Thermal overload: temperature within the chassis exceeds approximately +55°C. The thermal LED illuminates.
Off	Off	Failure of the +5 VDC.
On	On	Failure of the +12 VDC.
On	On	Failure of the -12 VDC.
Off	Off	Failure of the battery input.
Off	Off	Unit turned off.

### **Software-Related Alarms**

System managers set the alarm notification conditions when they configure the CLC. For more information refer to the *AI198 System Manager/User's Manual* for a list of CLC alarm levels and messages. For a list of Smart Line Card (SLC) alarms, refer to the appropriate SLC user's manual.

## Installing/ Replacing an RDC130-C Common Alarm Panel



**Warning:** Before handling equipment, you must be grounded by the mechanism provided at the installation site. Refer to the [Static Electricity \(ESD\)](#) component for more details.

1. Unpack the new RDC130-C and check for shipping damage.
2. If replacing the common alarm panel, locate the alarm panel on the cabled side of the AISwitch chassis.  
  
If installing the common alarm panel, locate the alarm panel location on the cabled side of the chassis.
3. Insert the RDC130-C Common Alarm Panel. See [Figure 6-1](#) for orientation of the common alarm panel.
4. If appropriate, make alarm connections which require the provided screw terminal connectors (AI Part 20-033-003).
5. Tighten the captive screws.



# Chapter 13: I710 Fuse Panel

## Overview



**Caution:** Before beginning the installation or replacement of the I710 Fuse Panel, put on a grounded, anti-static wrist strap. See the Static Electricity (ESD) component for more details regarding this precaution.

The I710 Fuse Panel provides current protection with redundant power distribution for 20 circuits using GMT type fuses. The I710 also can act as an alarm indicator for other equipment connected to the fuse panel. The redundant power distribution system feature provides continual power should one of the two input power sources be lost.

The panel operates at -48 VDC and distributes up to 60 amps of total current from two separate 30 amp current sources (A and B). Alarms and front panel indicators indicate failure of fuses, major bay alarms, and minor bay alarms.

### Cabled Side Connections

The following illustrates the cabled side of the fuse panel. A clear plastic cover on the cabled side protects technicians from accidental contact with the live power connections. This cover must be in place after the unit is installed.

**Figure 13-1: I710 Fuse Panel - Cabled Side**

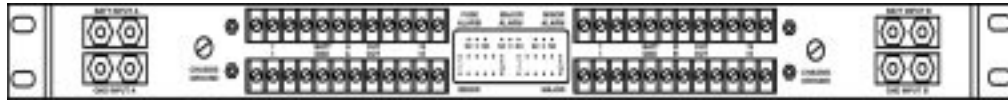

**Note:** Note: Input Terminal Block A is located on the left. Input Terminal Block B is located on the right.

Label	Description	Connects To
BATT INPUT A	Screw lug connector	-48V incoming power line from the battery backup
GND INPUT A	Screw lug connector	-48V incoming ground cable line
1 BATT A OUT 10 1 GND A OUT 10	10 position output terminal block	A piece of equipment within the bay, or in another bay which is being supplied by the fuse installed in the same numbered position on the faceplate side of the fuse panel.
FUSE ALARM	Wire wrap relay contacts to signal a failure of a fuse	The FUSE ALARM light on the faceplate side of the fuse panel. This can also be wired to some external light or audible aisle signal.
MAJOR ALARM	Wire wrap relay contacts to signal a major alarm failure in the bay	The MAJOR ALARM light on the faceplate side of the fuse panel. This can also be wired to some external light or audible aisle signal.
MINOR ALARM	Wire wrap relay contacts to signal a minor alarm failure in the bay	The MINOR ALARM light on the faceplate side of the fuse panel. This can also be wired to some external light or audible aisle signal.
1 BATT B OUT 10 1 GND B OUT 10	10 position output terminal block	A piece of equipment within the bay, or in another bay which is being supplied by the fuse installed in the same numbered position on the faceplate side of the fuse panel.

### Noncabled Side Connections

The following illustrates the noncabled faceplate side of the fuse panel. A paper label next to the fuse holders records which piece of equipment is connected to which fuse position.

**Figure 13-2: I710 Fuse Panel - Noncabled Side**



**Note:** Note: Fuse Block A is located on the left. Fuse Block B is located on the right.

Faceplate Label	Description	Connects To
1 A FUSE 10	10 vertical slots in which GMT fuses are inserted. If a fuse position is not used, a grey fuse spacer must be inserted into the fuse position.	The cabled side of the fuse panel screw connectors labeled: 1 BATT A OUT 10 1 GND A OUT 10 Fuse position 1A on the faceplate connects to BATT output terminal block position 1A on the cabled side, etc.
BATT TEST GND	Test point	The supply voltage can be safely tested at these points
FUSE ALARM	Alarm indication light	The wire wrap connections on the cabled side labeled FUSE ALARM
MAJOR ALARM	Alarm indication light	The wire wrap connections on the cabled side labeled MAJOR ALARM
MINOR ALARM	Alarm indication light	The wire wrap connections on the cabled side labeled MINOR ALARM
1 B FUSE 10	10 vertical slots in which GMT fuses are inserted. If a fuse position is not used, a grey fuse spacer must be inserted into the fuse position.	The cabled side of the fuse panel screw connectors labeled: 1 BATT B OUT 10 1 GND B OUT 10 Fuse position 1B on the faceplate connects to BATT output terminal block position 1B on the cabled side, etc.

## Technical Specifications

The following table lists technical specifications and descriptions for the I710 Fuse Panel.

**Table 13-1: I710 Fuse Panel Technical Specifications**

Specifications	Description
Dimensions	21 in. width, 12.75 in. depth, 1.75 in. height (23 in. width overall with brackets)
Weight	4.50 lbs.
Input Power Ratings	30 A in both A and B (60 A total)
Input Power Terminals	Two sets of two holed lugs on 5/8 in. center
Output Power Ratings	<ul style="list-style-type: none"> <li>● 30 A in both A and B (60 A total)</li> <li>● 10 outputs on both A and B (20 outputs total)</li> <li>● Each output can supply up to 10 A</li> </ul>
Output Power Terminals	Accommodate standard ring and spade lugs for wire sizes from #22 to #10 AWG
Input Voltage	-48 VDC
Current Capacity	30 A in both A and B (total of 60A)
Alarm Relay	2 A
Environmental Temperature Range	-17 ° C to 78 ° C (0 ° F to 150 ° F)



## Fuse Panel Operation

### Complete Circuit Fuse

The I710 output circuit and two separate input circuits from redundant power sources. Each input, A and B, internally connects through a set of power steering diodes to the fuse bus.

Through an installation of a GMT fuse, a completed circuit to the output connector is created. When a fuse fails, a signal travels to the fuse fail alarm relay circuit.

### Fuse Alarm

A front panel external light indicates a fuse failure. When a fuse fails, the fuse relay changes the normally open contacts to close. The relay also illuminates the fuse alarm light on the front panel.

### Bay Major and Minor Alarms

The major and minor alarms allow alarm signals from other sources to combine into a single output. These circuits operate by supplying a +48 VDC to one of the alarm input terminals on the cabled side.

Each circuit has a form C relay contact that operates when a fail condition exists. These contacts are used to operate external alarm circuits.

The bay major and bay minor alarm lights indicate the alarm status. When an alarm condition exists, the bay major alarm light indicates red while the minor light indicates yellow.

### Redundant Power Source

The redundant power source feature provides continual power if power to one of the two inputs is lost.

If one power source is offline, the remaining power source continues to provide the full power requirements of the panel. Either input A or B can distribute the power. The positive ground circuitry for both the A and B inputs must be common.

### GMT Fuses

The I710 utilizes black GMT fuses available at current ratings ranging from 18/100 amp to 10 amp. The fuse size utilized depends on the equipment attached to the fused circuit. Grey dummy fuses should occupy empty fuse positions.

## How to Install the I710 Fuse Panel

The mounting ears on the side of the fuse panel can be unscrewed and rotated so that the fuse panel can be mounted to either one inch or 1-1/4 inch spacing on the mounting rack. The mounting ears are installed at the factory in the one inch position.

Three mounting arrangements for the I710 in a bay exist including front, middle, and rear. Select the most appropriate arrangement dictated by the local office.



**Warning:** Observe the WARNING sign on the clear plastic cover on the cabled side of the fuse panel and take appropriate precautions for dealing with high voltage.

1. To reposition the mounting ear, if necessary, unscrew the three small screws on each mounting ear and move or rotate the ear to the desired position. Secure with the three screws.
2. Mount the fuse panel at the top of the rack. Insert and tighten the bay mounting screws to the mounting rack.
3. Remove the four double holed lugs from the cabled side of the I710.
4. Crimp the wires into the lugs using the appropriate sized crimping equipment.
5. Insert the lugged input power and ground lines onto the appropriate threaded terminal labeled BATT INPUT A, GND INPUT A, BATT INPUT B, GND INPUT B. Secure with the nuts and lockwashers supplied.
6. Turn on the power to the fuse panel.
7. Test the fuse panel voltage. Refer to [Testing and Maintaining the Fuse Panel](#) for details.
8. Turn off the power to the fuse panel.
9. Connect the input power and ground leads from the equipment being supplied to the selected output terminal position on the fuse bus on the cabled side of the fuse panel.
10. Record the name or code assigned to the piece of equipment being supplied on the labels on the faceplate side of the fuse panel.
11. Insert the appropriate size fuse into the fuse position for the equipment to be supplied through the fuse position. Refer to the [Fuse Panel Operation](#) section for testing and maintenance procedures.

12. Connect the wire wrap leads from the equipment for which a MAJOR alarm will be generated to the wire wrap pins on the cabled side of the fuse panel.
13. Connect the wire wrap leads from the equipment for which a MINOR alarm will be generated to the wire wrap pins on the cabled side of the fuse panel.
14. Connect the wire wrap leads from the equipment for which a FUSE alarm will be generated to the wire wrap pins on the cabled side of the fuse panel.
15. Place the clear plastic cover over the cabled side of the fuse panel and fasten in place with the screws provided.
16. Turn on the power to the fuse panel.
17. Test the connections. Refer to the [Testing and Maintaining the Fuse Panel](#) section for testing and maintenance procedures.

## Testing and Maintaining the Fuse Panel

### Testing the Fuse Panel

Although each unit has been tested at the factory, test both the A and B input circuits to verify that no damage occurred during shipping.

#### Voltage

- Use a voltmeter to test the voltage. Select the appropriate range on the voltmeter.

The voltmeter reading should be consistent with the central office voltage. This value often lies between -42V to -58V.

#### Fuse Alarm

- Place a blown fuse in one of the fuse positions.

The red fuse alarm light should operate.

The fuse alarm relay contacts should close between C and NO while the contacts should open between C and NC.

#### Bay Major and Minor Alarms

- Place a +48 VDC on one alarm input wire wrap terminals.

The red major light should operate from major input. The yellow minor light should operate from minor input.

The alarm relay contacts should close between C and NO while the contacts should open between C and NC.

### Maintaining the Fuse Panel

- Periodically inspect the unit for damage to the fuses, broken wires originating from the alarm circuits, and excess dust and dirt.
- Brush or wipe dust and dirt from the unit. Be careful not to damage the fuses.

## Installation of Equipment to the I710 Fuse Panel

1. On the noncabled side of the I710, select a grey dummy fuse in the slot to be occupied.
2. Record on the fuse index the slot number for the selected equipment to be serviced by this fuse position.
3. Install the equipment which is to be connected to the fuse panel.
4. Using wire of a gauge and insulation type in accordance with the governing wiring codes connect the wire to the selected position on the cabled side of the I710.  
  
Connect a wire pair to both the upper (negative) and bottom (positive) terminals.
5. Tag the wire at both ends to indicate polarity and panel circuit number.
6. Connect this wire pair to the equipment to be serviced by this fuse position as directed by the equipment manufacturers installation procedures.
7. Determine the appropriate fuse size from the installation manual for the equipment to be connected.
8. Acquire the appropriate sized GMT style fuse and insert it into the numbered position on the non-cabled side of the panel.
9. Turn on the installed equipment and verify proper operation of the equipment.

## How to Replace the I710 Fuse Panel



**Warning:** Observe the WARNING sign on the clear plastic cover for the cabled side of the fuse panel and take appropriate precautions for dealing with high voltage.

1. Turn off the power source to the fuse panel.
2. Remove the screws holding the clear plastic cover on the cabled side of the fuse panel.
3. Disconnect and tag the two lugged wires from the screws labeled BATT INPUT A, GND INPUT A, BATT INPUT B, GND INPUT B.
4. Disconnect and tag the wire wraps from the FUSE ALARM, MAJOR ALARM, and MINOR ALARM leads on the cabled side of the fuse panel.
5. Disconnect and tag the output and ground leads from the fuse bus for the equipment serviced by the fuse panel.
6. Remove the bay mounting screws in the brackets holding the fuse panel to the frame.
7. Remove the fuse panel and replace the unit. Refer to the [How to Install the I710 Fuse Panel](#) section for complete installation instructions.

# Chapter 14: AICOOL-48 Fan Unit

## AICOOL-48 Overview

The AICOOL-48 Fan Unit is a self-contained cooling unit which contains a tray of eight small fans. It mounts to the bottom of the AI180 chassis using key hole mounts.

The AICOOL-48 provides slide-out access to its components from the noncabled side of the unit. It also features the LED indicators and terminal block connectors on the cabled side of the unit.

Its purpose is to

- Keep the components of the AI180 Switch cool by forcing room temperature air into the AI180 chassis from underneath the chassis
- Provide an alarm output in the event of a unit or major component failure in the AICOOL-48

## AICOOL-48 Technical Specifications

The technical specifications of the AICOOL-48 Fan Unit are listed in [Table 14-1](#).

**Table 14-1: Technical Specifications for the AICOOL-48**

Specification	Dimension
Size	Width: 16.8 in. Depth: 9.3 in. Height: 2 in.
Weight	8 lb. 10.5 oz.
Normal Operating Temperature	<ul style="list-style-type: none"> <li>● 40 to 100 °F</li> <li>● 4.5 to 38 °C (0 to 50 °C Maximum)</li> </ul>
Power Input	<ul style="list-style-type: none"> <li>● 0.8 A at -48 V Nominal 3 A surge</li> <li>● Range: -36 VDC to -60 VDC maximum</li> </ul>
Maximum Power Consumption	1.0 A at -48 V
Redundant DC Power Inputs	Supplies power to the fans and control logic card
Output Alarm	One normally closed (NC) and normally open (NO) fail safe relay contact
Fan Alarm	30 to 40% decrease from nominal rotation
DC Power Alarm	Fault indicated if either fuse opens or input supply voltage drops below 25 V
Alarm Test Button	Activation produces an alarm for verification of wiring
3 A Fuses	Access to 3 A fuses from the cabled side of the unit
Available Accessories	Alternate method (side strap) mounting straps



## AICOOL-48 Components

The AICOOL-48 Fan Unit components include

- Main housing section consisting of the AICOOL-48 outer frame and its connectors
- Fan tray section consisting of eight fans and the control logic card along with the light indicator panel and terminal block connector
- Filter section containing filter and cover plate
- Temperature sensing attachment
- Heat baffle attachment

**Note:** The heat baffle attachment is not shipped with the AICOOL-48. The heat baffle attachment is a recommended component of the AICOOL-48.

## AICOOL-48 Main Housing Section

The main housing section of the AICOOL-48 consists of the outer frame and its connectors.

The outer frame has four keyholes (see “A” in [Figure 14-1](#)) mounted on the top of the frame. These keyholes align with the screw holes on the underside of the AI180. There are also 12 alternate method (side strap) mounting holes.

The noncabled side of the AICOOL-48 main housing section has two faceplates. The top faceplate is the fan tray unit housing no controls. The bottom faceplate allows access to the filter.

The cabled side of the main housing contains a fan tray containing the terminal block connectors for the temperature sensor, alarms, and power cables. The fan tray section also contains the fuses and indicator lights for the alarms.

**Figure 14-1: Main Housing Section - Noncabled Side**

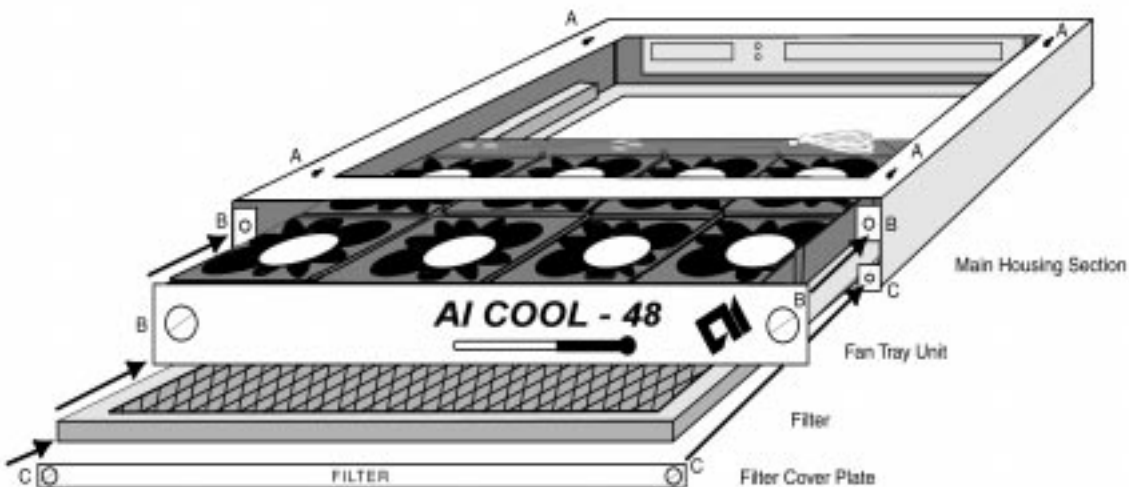

## AICOOL-48 Fan Tray Section

The fan tray of the AICOOL-48 contains eight cooling fans and a control logic card.

This section slides out the noncabled side of the main housing when the screws on the faceplate are loosened. See [Figure 14-2](#) and [Figure 14-3](#) for the exact location of the components. The cabled side of the fan tray contains the light indicator panel and the terminal block connectors.

**Figure 14-2: Fan Tray Section - Noncabled Side**

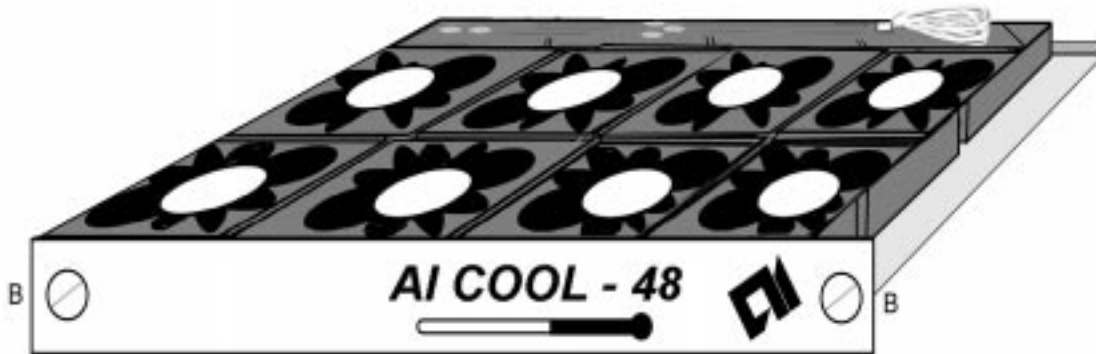

**Figure 14-3: Fan Tray Section - Cabled Side**

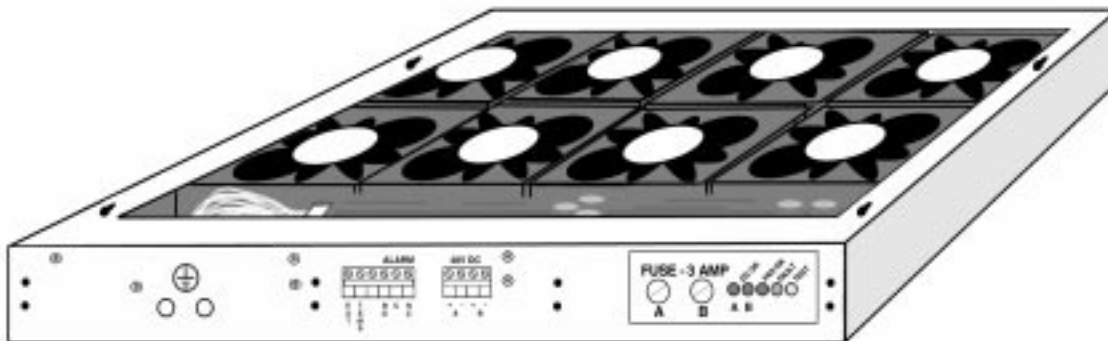

### Light Indicator Panel

The light indicator panel is located on the cabled side of the fan tray section in the right corner. The lights indicate operation status of the AICOOL-48. Refer to the [AICOOL-48 Light Indicator Troubleshooting Guide](#) for LED indicator status.

Figure 14-4: Light Indicator Panel - Cabled Side

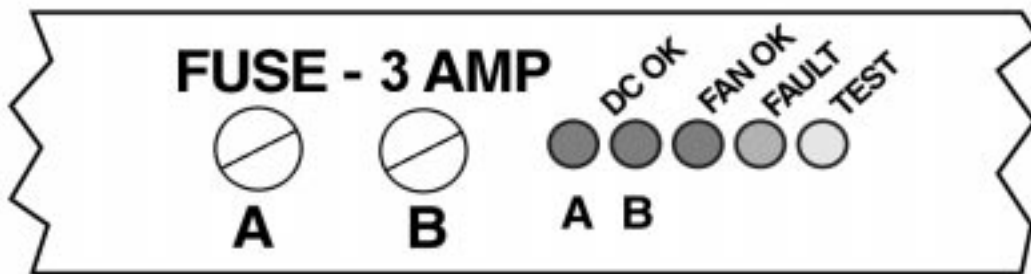

Table 14-2: AICOOL-48 Light Indicator Panel Components

Component	Description
Fuse 3 AMP	Two fuses are located on the right side of the faceplate. Fuse A is wired to the A power source in the fan tray assembly. Fuse B is wired to the B power source in the fan tray assembly.
Green Indicator Lights	Located on the right side of the faceplate, the three green lights are lit for normal operation. DC OK <ul style="list-style-type: none"> <li>Indicator light A - This green indicator light connects to the DC input for the A power source in the fan tray unit. If this light is not lit, a problem exists with power source A.</li> <li>Indicator light B - This green indicator light connects to the DC input for the B power source in the fan tray unit. If this light is not lit, a problem exists with power source B.</li> </ul> FAN OK <ul style="list-style-type: none"> <li>This indicator light connects to the fans. If any of the fans lose speed (approximately 50% decrease from normal) or fail, this light goes out and the red FAULT turns on.</li> </ul>
Red Indicator Light	FAULT <ul style="list-style-type: none"> <li>This red indicator light signals that an alarm has been activated.</li> </ul>
TEST button	This test button allows you to test the alarms to verify proper functionality.

### AICOOL-48 Terminal Block Connectors

The terminal blocks on the cabled side of the main housing on the AICOOL-48 connect according to [Table 14-3](#).

**Table 14-3: AICOOL-48 Terminal Block Connector Locations**

Block Label	Connection Label	Connects
ALARM	EXT	Connects to the temperature sensor, if mounted, in the heat baffle
	TEMP	Connects to the temperature sensor, if mounted, in the heat baffle
	BLANK	Not used
	NO	Normally open fail safe circuit of the alarm internal relay
	C	Common circuit of the alarm internal relay
	NC	Normally closed fail safe circuit of the alarm internal relay
48 VDC	A	Connects to the external 48 V power supply
	B	Connects to the external, redundant 48V power supply

The following diagram illustrates the locations of the connectors on the noncabled side of the AICOOL-48.

**Figure 14-5: AICOOL-48 Terminal Block Connectors - Cabled Side**

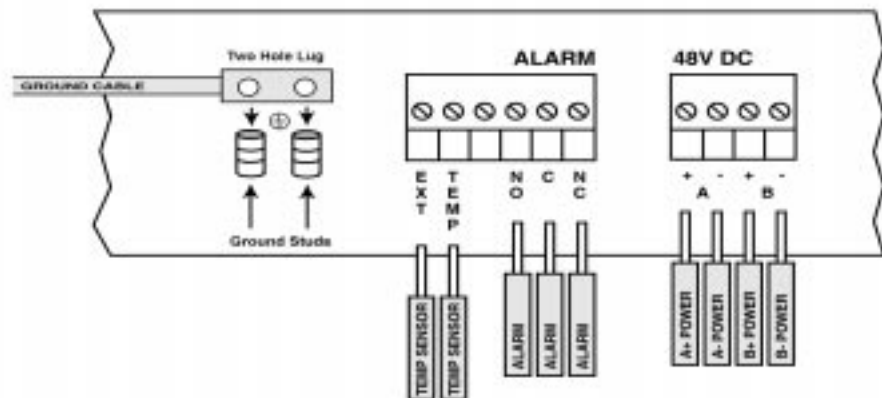

### AICOOL-48 Jumper Settings

Two jumper settings are located on the control logic card. The jumper labeled J1 activates the temperature sensor. See [Activating the Temperature Sensor](#) for more information.

The jumper labeled J12 is shipped from the factory not populated. This jumper can be installed to make the alarms circuit ignore the power source “B” connection. This feature can be used for special applications where only one power source is connected. Do not attempt to populate this jumper. Contact Technical Support for further information.

**Figure 14-6: AICOOL-48 Jumper Settings**

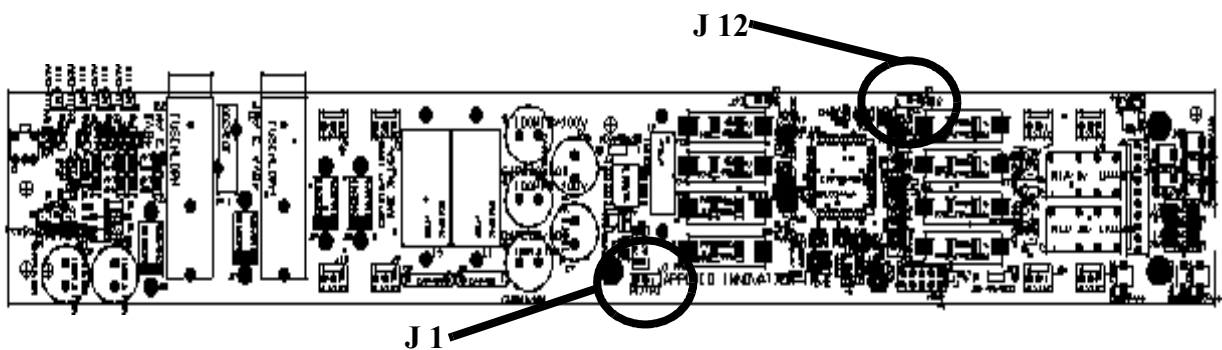

**AICOOL-48  
Filter Section**

The filter section includes a cover plate and the filter. This filter prevents excessive dirt from entering the chassis while the air is being circulated. It is accessed by loosening the two screws (C) on the filter cover plate. See the [Replacing/Maintaining the AICOOL-48 Fan Components](#) section for instructions on replacing and maintaining the filter.

See [Figure 14-1](#) for the placement of the filter section.

**Figure 14-7: AICOOL-48 Filter Section - Noncabled Side**

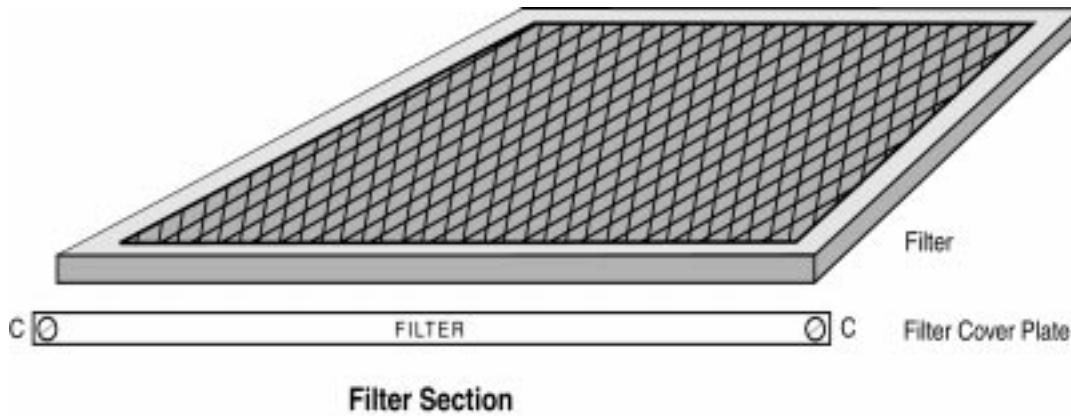

## Temperature Sensor

Located below the heat baffle, the temperature sensor detects excessive heat at the chassis and shuts down the AICOOL-48 fans and activates the fault alarm output. This attachment is recommended as an extra precaution against heat damage to your chassis or cards.

**Note:** If the temperature sensor is not already installed on the AI180 chassis, uninstall the heat baffle. Install the temperature sensor and replace the heat baffle.

### Installing the Temperature Sensor



**Caution:** Before installing the temperature sensor, put on a grounded, antistatic wrist strap. Read the [Static Electricity \(ESD\)](#) component for more details.

1. Thread the temperature sensor cable through the grommet hole in the side of the heat baffle. Refer to [Figure 14-8](#) for installing the temperature sensor.
2. Anchor the sensor to the mounting stud located in the top inside center of the heat baffle, with the nut and washer provided.
3. Secure the temperature sensor cable to the sides of the chassis with cable clamps.
4. Connect the leads from the temperature sensing cable to the EXT and TEMP connections on the cabled side of the AICOOL-48 unit. The EXT and TEMP connections are labeled on the ALARM terminal block connector.

The wires can be connected interchangeably.



The following diagram illustrates the installations of the temperature sensing assembly on the AI180 chassis and heat baffle.

**Figure 14-8: Temperature Sensor Assembly - Noncabled Side**

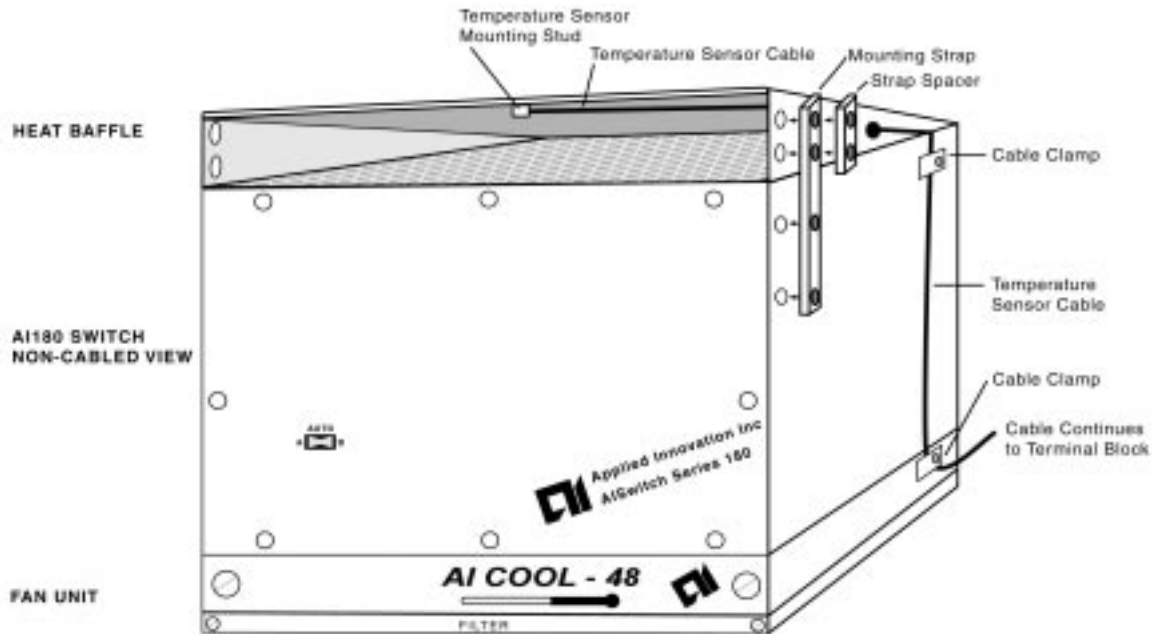

### Activating the Temperature Sensor

Jumper 1 located on the control logic card controls fan tray usage. To activate the temperature sensor, remove the cap and move the jumper to occupy position 1 and 2. See [Figure 14-6](#) for location of the jumper.

## Heat Baffle

The heat baffle is required when installing an AICOOL-48 Fan Unit. This baffle deflects the air flow at the top of the chassis away from the components loaded in the mounting rack above the chassis. It also directs the air flow away from any personnel who may be working on the cabled side of the chassis.

**Note:** The heat baffle may already be installed on the AI180 chassis.

### Installing the Heat Baffle



**Caution:** Before installing the heat baffle, put on a grounded, antistatic wrist strap. Read the [Static Electricity \(ESD\)](#) component for more details.

1. Place the heat baffle on top of the AI180 chassis so that the open edge faces the noncabled side of the chassis.
2. Place the mounting straps over the screw holes provided in the baffle and install the screws.
3. Use the special spacers provided if the chassis or mounting rack dimensions vary enough to justify the need.
4. Align the screw holes from the straps to the chassis and install the screws.

**Figure 14-9: Heat Baffle Installation**

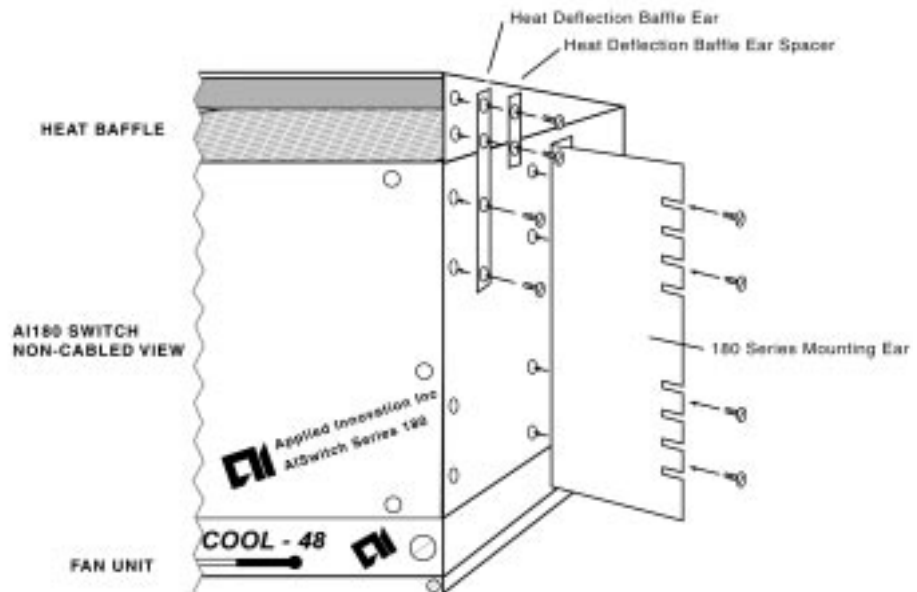

## Installing the AICOOL-48 Fan Unit



**Caution:** Before installing the AICOOL-48, put on a grounded, anti-static wrist strap. Read the [Static Electricity \(ESD\)](#) component for more details.

1. Disassemble the AICOOL-48 fan tray and filter unit from the AICOOL-48 main housing.
2. Before installing the fan unit, loosen the two captive screws on the filter cover plate and remove the cover plate and filter.
3. Loosen the two captive screws on the fan tray section and slide the fan tray all the way out.
4. Partially thread four screws (AI Part 00-018-001) into the bottom portion of the AI180 chassis.
5. Mount the main housing section to the mounting rack on the underside of the AI180 chassis. The cabled side of the AICOOL-48 main housing sections aligns with the cabled side of the AI180 chassis.
6. Align the large portion of the key holes located on the fan housing unit, over the heads of the screws. Push the main housing section up against the bottom of the AI180 chassis. Slide the housing towards the cabled side of the chassis and tighten the screws.

If you encounter difficulty aligning the screws, contact Technical Support for resolution of the problem.

7. Connect the temperature sensor wiring to the terminal block connector points. See the [Temperature Sensor](#) section for details of this connection.
8. Replace the fan tray, filter, and filter cover plate. Tighten the captive screws.
9. Remove the fuses from the cabled side of the AICOOL-48.
10. Strip the A and B power source cables approximately 1/4 inch and insert them into the appropriate terminal block positions. Tighten the screws above each cable. See [Figure 14-5](#) for exact locations.
11. Strip the temperature sensor wires about 1/4 inch and connect the wires to the EXT and TEMP labeled connection points on the ALARM block. Tighten the connection screws. See [Figure 14-5](#) for exact locations.

The wires can be connected interchangeably.

12. From the external alarm monitoring device, strip the lead wires about 1/4 inch and connect them to the NC (normally closed), NO (normally open), or C (common) terminal block positions. Tighten the screws to secure the wires. See [Figure 14-5](#) for exact locations.
13. Strip the ground cable 1/4 inch, attach the two hole lug, and secure with a lock washers and nuts to the ground studs on the cabled side of the AICOOL-48.
14. Replace or install the needed fuses and check the light indicator panel for proper operation. See the [AICOOL-48 Light Indicator Troubleshooting Guide](#) table for details.
15. Press the test button to insure proper operation.
16. Mount the four D rings using the supplied lockwashers and screws.

## Replacing/ Maintaining the AICOOL-48 Fan Components

### Replacing/Maintaining the Filter

The filter for the AICOOL-48 should be cleaned once each month. To clean the filter:

1. Loosen the captive screws from the cover plate. Set the plate aside.
2. Gently grasp the front edges of the filter and pull straight out of the main housing.
3. Clean the filter with water or compressed air.
4. Rinse thoroughly and dry completely. This prevents excessive moisture from entering the chassis.
5. Replace the filter and screw the cover plate in place.
6. Replace the filter with a custom AI filter (AI Part 06-180-066) every one or two years depending on the wear and conditions in the room housing the AICOOL-48.

### Replacing Fuses

The AICOOL-48 requires two 3 Amp 3AG type fuses (AI Part 19-011-030).

1. Pull the fuse out of the noncabled side of the main housing.
2. Replace the fuse and restore power to the unit.

### Replacing/Maintaining the Fan Tray

If the red FAULT light indicates a problem in the fan tray, and the failure cannot be corrected using [Table 14-4](#), the entire tray must be returned to the factory to be repaired.

1. Loosen the captive screws from the fan tray faceplate.
2. Pull the fan tray unit out.
3. Install the spare fan tray in the main fan housing to keep the unit operational.
4. Return the fan tray unit to the factory for repair or replacement.

**AICOOL-48  
Light Indicator  
Troubleshooting  
Guide**

The following table lists specific conditions that might occur and the action to be taken when the fan tray section faceplate indicator lights signal a problem.

**Table 14-4: AICOOL-48 Light Indicator Troubleshooting Guide**

<b>DC OK “A” light</b>	<b>DC OK “B” light</b>	<b>FAN OK Green light</b>	<b>FAULT Red light</b>	<b>Alarm Relay</b>	<b>Condition</b>	<b>Action</b>
ON	ON	ON	OFF	No Alarm	All systems normal	
OFF	ON	ON	ON	Alarm	Fuse “A” open or source “A” less than 25 V	Replace the “A” fuse or verify source “A” is 48 V.
ON	OFF	ON	ON	Alarm	Fuse “B” open or source “B” less than 25 V	Replace the “B” fuse or verify source “B” is 48 V.
ON	ON	OFF	ON	Alarm	Fan failure or temperature sensor failure	Replace the fan tray and return the faulty fan tray unit to the factory.
OFF	OFF	OFF	OFF	Alarm	Alarm logic card	Contact Technical Support. You may need to return the entire AICOOL-48 to the factory.
ON	ON	ON	ON	Alarm	Alarm test button may be stuck	Depress and release the test button. If lights do not return to normal readings, contact Technical Support.

# Chapter 15: Distribution Panels

## Overview

Distribution panels provide patching, distribution, consolidation, and termination for many of the cable types used in central offices, operations centers, and other telecommunication facilities. The type of distribution panel used relates to a specific card.

Some panels are available for either 19-inch (48.26 cm) rack mounting units or 23-inch (58.42) rack mounting units. The panels provide cable management and convenient cable and connector access. The distribution panels act as an extension of the associated card. The cable between the faceplate and distribution panel is proprietary.

**Table 15-1: Distribution Panels**

Distribution Panel	Size Available	Associated Card
DP120	19-inch (48.26 cm) 23-inch (58.42 cm)	AI120 (dry contact closure inputs only)
DP120A	19-inch (48.26 cm)	AI120
DP185	19-inch (48.26 cm) 23-inch (58.42 cm)	AI185
DP185B	19-inch (48.26 cm) 23-inch (58.42 cm)	AI185 Revision 5
DP185RJ45	19-inch (48.26 cm) 23-inch (58.42 cm)	AI185
DP194	19-inch (48.26 cm) 23-inch (58.42 cm)	AI194
DP196	19-inch (48.26 cm) 23-inch (58.42 cm)	AI196 cards
I709	23-inch (58.42 cm)	Generic
I711	23-inch (58.42 cm)	Generic

## D Ring Cable Management

As part of a cable wire management system, D rings handle wires to prevent cable clustering. The DP120, DP120A, I709, and I711 are mounted on a D ring panel. Available D rings include:

- 2 inch height by 3 inch depth (5.08 cm height by 7.62 cm depth)
- 2 inch height by 4 inch depth (5.08 cm height by 10.16 cm depth)
- 4 inch height by 4 inch depth (10.16 cm height by 10.16 cm depth)

**Note:** The I709 and I711 are not available with the 4 inch by 4 inch (10.16 cm by 10.16 cm) D rings.



## Installing a Distribution Panel

Each distribution panel arrives with point of origin tags on the panel.

1. Place the distribution panel in the selected position in the rack. See [Figure 15-1](#) for clearance requirements.

**Figure 15-1: Distribution Panel Clearance Requirements**

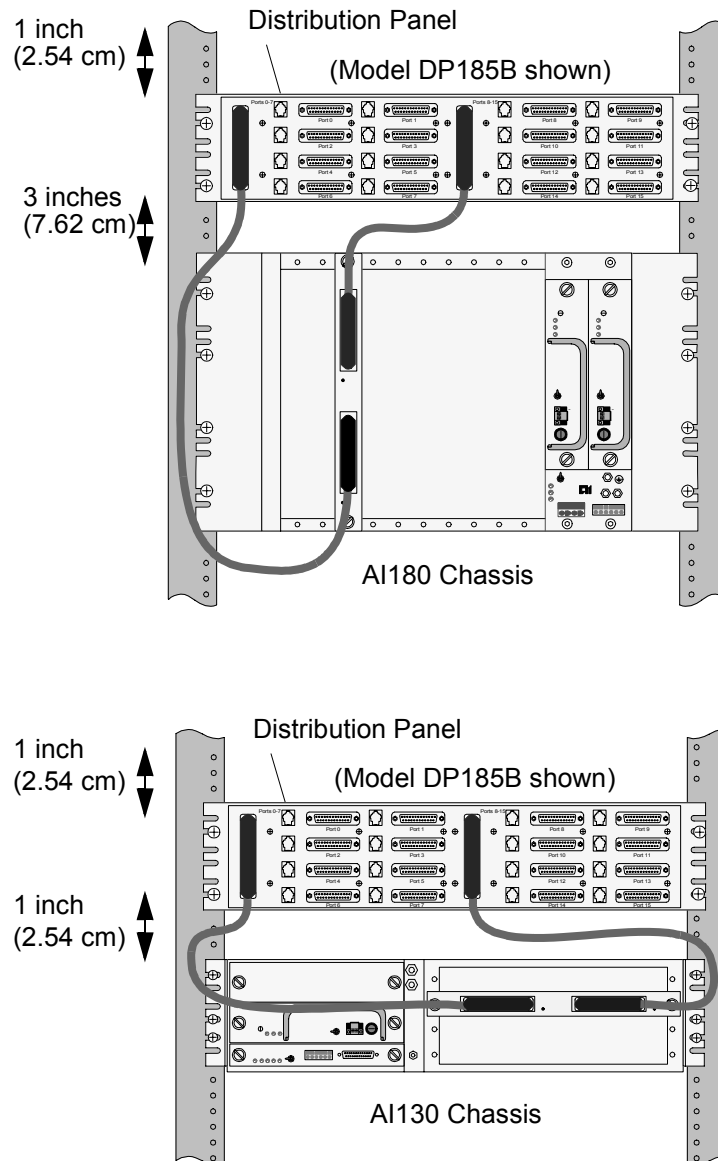

2. Screw four mounting screws into the panel to connect the distribution panel to the rack.  
Ensure panel is electrically contained in rack for proper grounding.

3. Connect the network elements to the distribution panel ports.

It is optional to remove the point of origin tags from the cables after installation.

## **Replacing a Distribution Panel**

1. Before removing the cables, label and tag each cable with point of origin and point of termination markers.
2. Unplug the cables from the distribution panel.
3. Unscrew the four mounting screws.
4. Remove the distribution panel.
5. Replace the distribution panel.
6. Screw four mounting screws into the panel to connect it to the rack.
7. Install the corresponding cables into the distribution panel.

It is optional to remove the point of origin and point of termination tags from the cables after replacement of the distribution panel.

DP120 Overview

Figure 15-2: Distribution Panel 120

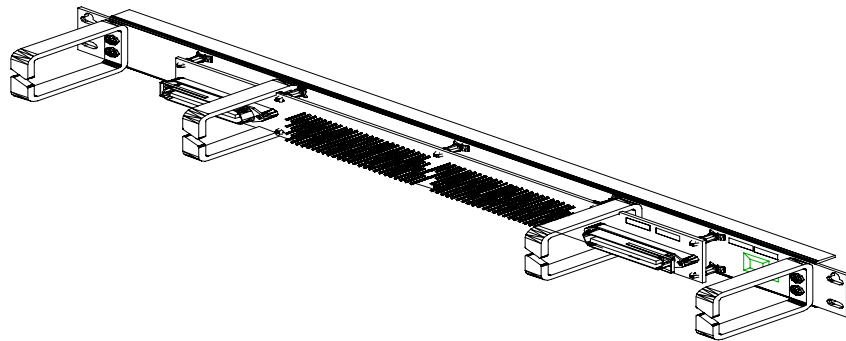

**Note:** For use with the AI120. Supports dry contact closure inputs and Form “C” dry contact closure outputs.

Table 15-2: DP120 Technical Specifications

<b>Mounting</b>	Available for 19-inch (48.26 cm) or 23-inch (58.42) rack mounting unit	
<b>I/O Ports</b>	Two 50-pin connectors; Two 100-pin wire wrap blocks	
<b>Connector Pins</b>	<b>Pin outs/ wire wraps</b>	<b>Signal</b>
	1-32 33-47 48-100	Dry contact closure inputs Form “C” contact closure outputs Signal Ground
<b>Cables</b>	<ul style="list-style-type: none"> <li>CAB50 - DP120 to AI120 (50-pin Telco connectors)</li> </ul>	

## DP120A

### Overview

The DP120A serves as the interface between the network element to be monitored and the AI120. It accepts either an unpowered contact closure (dry contact) to ground, or an active signal (3.5 to 75 VDC) as an input. The DP120A provides complete optical isolation between the AI120 and the NE's alarm output. The DP120A also allows access to the AI120's 10 internal alarm relays.

The DP120A connects to the AI120 using two CAB50 cables. The DP120A mounts in either a 19-inch or 23-inch bay.

The DP120A consists of two major components including the active panel board and the terminal board. The active panel board plugs into the terminal board perpendicularly and is enclosed in a metal box which provides protection against accidental contact with live voltage. The active panel will be attached to the terminal panel prior to shipping.

The DP120A utilizes 110 size punch down blocks to terminate the wiring for all 64 alarm inputs and the 10 alarm relays in the AI120. The punch down blocks are arranged in two groups. The group on the left side accepts channels 1 through 32 and provides access to AI120 relay contacts 1 through 5. The group on the right side accepts channels 33 through 64 and provides access to relay contacts 6 through 10.

The DP120A uses the 110 size punch down blocks for all wiring connections except the power. Always use a single wire termination tool set on the low-impact setting.

The signal conditioning circuitry is capable of utilizing either a powered or unpowered (dry contact closure to ground) contact as an input. Refer to the [Input Configurations](#) illustration. Input wiring is terminated as follows:

### Unpowered Contact Closure to Ground

The alarm output of the NE consists of a relay that either closes or opens a circuit.

**Note:** The DP120A must be connected to a power source (5 to 75 VDC) to accept this type of input.

### Actively Powered Signal

The alarm output of the NE consists of a voltage (3.5 to 75 VDC) that is either on or off.

### DP120A Faceplate and Connectors

The following graphic describes the faceplate and connectors associated with the DP120A.

**Figure 1: DP120A Faceplate**

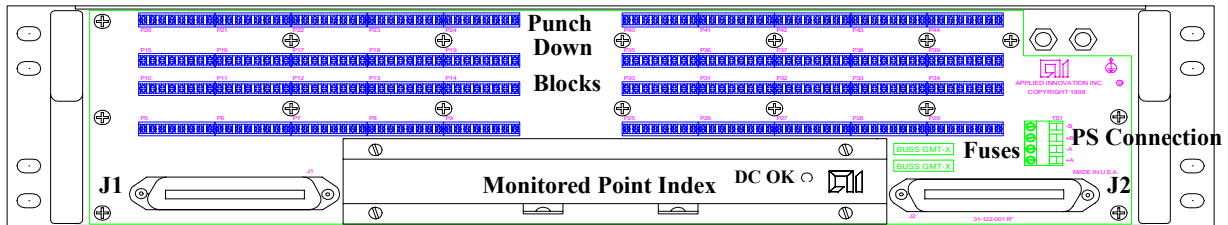

**Note:** The graphic callouts that appear on this graphic are for reference only. These callouts do not appear on the physical layout of the DP120A.

Label	Description
J1	This is a 50-pin connector to the AI120 (inputs 1-32).
J2	This is a 50-pin connector to the AI120 (inputs 33-64).
DC OK	This green LED indicates that the DC power supply is active.
Punch Down Blocks	The group on the left side accepts channels 1-32 and provides access to AI120 relay contacts 1-5. The group on the right side accepts channels 33-64 and provides access to relay contacts 6-10.
PS Connection	This is the power supply connection. Use this only if you need to supply power to the DP120A. Refer to the <a href="#">DP120A Installation Notes</a> .
Fuses	The fuses are used to interrupt the power supply if the current exceeds the fuse rating and used to avoid damage to the DP120A. These are not redundant fuses.
	
<b>Caution:</b>	Wiring for an improper grounding system will cause the fuses to fail.
Monitored Point Index	This is the cover plate used to enclose the active circuitry panel. The tabs on the bottom of this cover are intended to provide a storage place for the <a href="#">DP120A Installation Notes</a> . The DP120A Installation Notes are shipped with every AI120 that has a DP120A as its distribution panel.

## DP120A Installation Notes

**Note:** A separate copy of these installation notes are shipped with every AI120 that has a DP120A as its distribution panel. The installation notes have been included in these release notes for reference.



**Caution:** Punch down blocks will accept 22 or 24 AWG solid or stranded wire. Always use the low-impact setting on the single wire termination tool. Use an AMP impact tool 558418-1, an AT&T D-814, a KRONE Universal wire insertion tool or the equivalent.

If you use unpowered contact closures to ground as alarm signals, use panel power of 5 to 75 VDC (Central Office battery DC power). Each signal input is capable of supporting a 3.5 to 75 VDC active alarm signal with either a positive or negative ground reference (Central Office battery ground). Each input's signal conditioning will use approximately 2mA from the activating signal.

The active panel does all signal conditioning and is located in the metal enclosure. If it needs to be serviced, refer to the hardware manual for instructions.

### *Input Configurations*

The following figure depicts the input configurations allowed for an unpowered contact with the panel power at positive ground, an unpowered contact with the panel power at negative ground, and the active alarm signal.

Figure 2: Input Configurations



**Caution:** Use only one unpowered input configuration. Use the selected input configuration consistently to avoid damage to the DP120A.

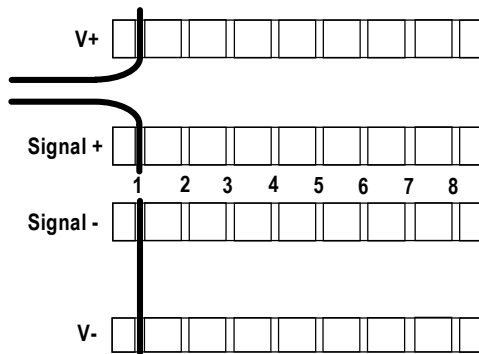

**Unpowered Contact with Panel Power at Positive Ground**

In this case, you need to supply power to the panel. Jumper power from the V- bus to one end of the input circuit. Apply the alarm signal between the other end of the input circuit and the ground on the V+ bus.

**Powered Alarm Signal**  
No separate power is required.

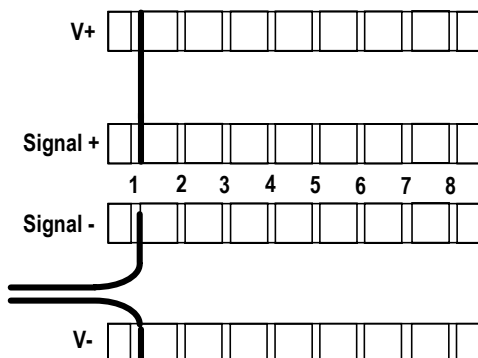
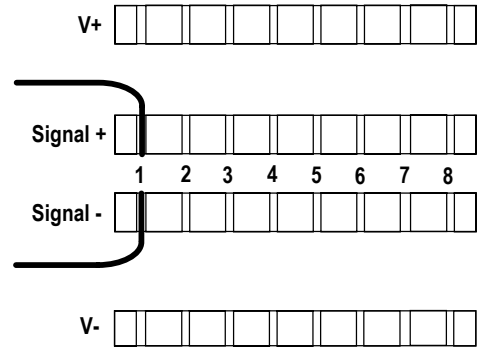

**Unpowered Contact with Panel Power at Negative Ground**

In this case, you need to supply power to the panel. Jumper power from V+ bus to one end of the input circuit. Apply the alarm signal between the other end of the input circuit and ground on the V- bus.

*Worksheets*

Use the following worksheet to keep track of the DP120A inputs and monitoring points.

**Table 1: DP120A Inputs and Monitoring Points Worksheet**

<b>Input #</b>	<b>Monitored Point</b>	<b>Input #</b>	<b>Monitored Point</b>
01		33	
02		34	
03		35	
04		36	
05		37	
06		38	
07		39	
08		40	
09		41	
10		42	
11		43	
12		44	
13		45	
14		46	
15		47	
16		48	
17		49	
18		50	
19		51	
20		52	
21		53	
22		54	
23		55	
24		56	



<b>Input # (Continued)</b>	<b>Monitored Point</b>	<b>Input #</b>	<b>Monitored Point</b>
25		57	
26		58	
27		59	
28		60	
29		61	
30		62	
31		63	
32		64	

### Connector Pin Assignments

The DP120A is connected to the AI120 with two 50-pin connectors. One cable is labeled J1, and the other is labeled J2. The following tables describe the pin connector assignment for both connectors.

**Table 2: DP120A J1 Connector Pin Assignments**

J1 Pin Numbers	Signal Name	Type of Signal	Description
1	INPUT 1	INPUT	ALARM INPUT TO 120
2	INPUT 2	INPUT	ALARM INPUT TO 120
3	INPUT 3	INPUT	ALARM INPUT TO 120
4	INPUT 4	INPUT	ALARM INPUT TO 120
5	INPUT 5	INPUT	ALARM INPUT TO 120
6	INPUT 6	INPUT	ALARM INPUT TO 120
7	INPUT 7	INPUT	ALARM INPUT TO 120
8	INPUT 8	INPUT	ALARM INPUT TO 120
9	INPUT 9	INPUT	ALARM INPUT TO 120
10	INPUT 10	INPUT	ALARM INPUT TO 120
11	INPUT 11	INPUT	ALARM INPUT TO 120
12	INPUT 12	INPUT	ALARM INPUT TO 120
13	INPUT13	INPUT	ALARM INPUT TO 120
14	INPUT 14	INPUT	ALARM INPUT TO 120
15	INPUT 15	INPUT	ALARM INPUT TO 120
16	INPUT 16	INPUT	ALARM INPUT TO 120
17	INPUT 17	INPUT	ALARM INPUT TO 120
18	INPUT 18	INPUT	ALARM INPUT TO 120
19	INPUT 19	INPUT	ALARM INPUT TO 120
20	INPUT 20	INPUT	ALARM INPUT TO 120
21	INPUT 21	INPUT	ALARM INPUT TO 120
22	INPUT 22	INPUT	ALARM INPUT TO 120
23	INPUT 23	INPUT	ALARM INPUT TO 120

<b>J1 Pin Numbers (Continued)</b>	<b>Signal Name (Continued)</b>	<b>Type of Signal (Continued)</b>	<b>Description (Continued)</b>
24	INPUT 24	INPUT	ALARM INPUT TO 120
25	INPUT 25	INPUT	ALARM INPUT TO 120
26	INPUT 26	INPUT	ALARM INPUT TO 120
27	INPUT 27	INPUT	ALARM INPUT TO 120
28	INPUT 28	INPUT	ALARM INPUT TO 120
29	INPUT 29	INPUT	ALARM INPUT TO 120
30	INPUT 30	INPUT	ALARM INPUT TO 120
31	INPUT 31	INPUT	ALARM INPUT TO 120
32	INPUT 32	INPUT	ALARM INPUT TO 120
33	RELAY 1 COM	OUTPUT	AI120 Alarm Relay common
34	RELAY 1 NC	OUTPUT	AI120 Alarm Relay normally closed
35	RELAY 1 NO	OUTPUT	AI120 Alarm Relay normally open
36	RELAY 2 COM	OUTPUT	AI120 Alarm Relay common
37	RELAY 2 NC	OUTPUT	AI120 Alarm Relay normally closed
38	RELAY 2 NO	OUTPUT	AI120 Alarm Relay normally open
39	RELAY 3 COM	OUTPUT	AI120 Alarm Relay common
40	RELAY 3 NC	OUTPUT	AI120 Alarm Relay normally closed
41	RELAY 3 NO	OUTPUT	AI120 Alarm Relay normally open
42	RELAY 4 COM	OUTPUT	AI120 Alarm Relay common
43	RELAY 4 NC	OUTPUT	AI120 Alarm Relay normally closed
44	RELAY 4 NO	OUTPUT	AI120 Alarm Relay normally open

<b>J1 Pin Numbers (Continued)</b>	<b>Signal Name (Continued)</b>	<b>Type of Signal (Continued)</b>	<b>Description (Continued)</b>
45	RELAY 5 COM	OUTPUT	AI120 Alarm Relay common
46	RELAY 5 NC	OUTPUT	AI120 Alarm Relay normally closed
47	RELAY 5 NO	OUTPUT	AI120 Alarm Relay normally open
48	AI GROUND	GROUND	AI 120 GROUND
49	AI GROUND	GROUND	AI 120 GROUND
50	AI GROUND	GROUND	AI 120 GROUND

**Table 15-3: DP120A J2 Connector Pin Assignments**

<b>J2 Pin Numbers</b>	<b>Signal Name</b>	<b>Type of Signal</b>	<b>Description</b>
1	INPUT 33	INPUT	ALARM INPUT TO 120
2	INPUT 34	INPUT	ALARM INPUT TO 120
3	INPUT 35	INPUT	ALARM INPUT TO 120
4	INPUT 36	INPUT	ALARM INPUT TO 120
5	INPUT 37	INPUT	ALARM INPUT TO 120
6	INPUT 38	INPUT	ALARM INPUT TO 120
7	INPUT 39	INPUT	ALARM INPUT TO 120
8	INPUT 40	INPUT	ALARM INPUT TO 120
9	INPUT 41	INPUT	ALARM INPUT TO 120
10	INPUT 42	INPUT	ALARM INPUT TO 120
11	INPUT 43	INPUT	ALARM INPUT TO 120
12	INPUT 44	INPUT	ALARM INPUT TO 120
13	INPUT 45	INPUT	ALARM INPUT TO 120
14	INPUT 46	INPUT	ALARM INPUT TO 120
15	INPUT 47	INPUT	ALARM INPUT TO 120
16	INPUT 48	INPUT	ALARM INPUT TO 120

<b>J2 Pin Numbers (Continued)</b>	<b>Signal Name (Continued)</b>	<b>Type of Signal (Continued)</b>	<b>Description (Continued)</b>
17	INPUT 49	INPUT	ALARM INPUT TO 120
18	INPUT 50	INPUT	ALARM INPUT TO 120
19	INPUT 51	INPUT	ALARM INPUT TO 120
20	INPUT 52	INPUT	ALARM INPUT TO 120
21	INPUT 53	INPUT	ALARM INPUT TO 120
22	INPUT 54	INPUT	ALARM INPUT TO 120
23	INPUT 55	INPUT	ALARM INPUT TO 120
24	INPUT 56	INPUT	ALARM INPUT TO 120
25	INPUT 57	INPUT	ALARM INPUT TO 120
26	INPUT 58	INPUT	ALARM INPUT TO 120
27	INPUT 59	INPUT	ALARM INPUT TO 120
28	INPUT 60	INPUT	ALARM INPUT TO 120
29	INPUT 61	INPUT	ALARM INPUT TO 120
30	INPUT 62	INPUT	ALARM INPUT TO 120
31	INPUT 63	INPUT	ALARM INPUT TO 120
32	INPUT 64	INPUT	ALARM INPUT TO 120
33	RELAY 6 COM	OUTPUT	AI120 Alarm Relay common
34	RELAY 6 NC	OUTPUT	AI120 Alarm Relay normally closed
35	RELAY 6 NO	OUTPUT	AI120 Alarm Relay normally open
36	RELAY 7 COM	OUTPUT	AI120 Alarm Relay common
37	RELAY 7 NC	OUTPUT	AI120 Alarm Relay normally closed
38	RELAY 7 NO	OUTPUT	AI120 Alarm Relay normally open
39	RELAY 8 COM	OUTPUT	AI120 Alarm Relay common

<b>J2 Pin Numbers (Continued)</b>	<b>Signal Name (Continued)</b>	<b>Type of Signal (Continued)</b>	<b>Description (Continued)</b>
40	RELAY 8 NC	OUTPUT	AI120 Alarm Relay normally closed
41	RELAY 8 NO	OUTPUT	AI120 Alarm Relay normally open
42	RELAY 9 COM	OUTPUT	AI120 Alarm Relay common
43	RELAY 9 NC	OUTPUT	AI120 Alarm Relay normally closed
44	RELAY 9 NO	OUTPUT	AI120 Alarm Relay normally open
45	RELAY 10 COM	OUTPUT	AI120 Alarm Relay common
46	RELAY 10 NC	OUTPUT	AI120 Alarm Relay normally closed
47	RELAY 10 NO	OUTPUT	AI120 Alarm Relay normally open
48	AI GROUND	GROUND	AI 120 GROUND
49	AI GROUND	GROUND	AI 120 GROUND
50	AI GROUND	GROUND	AI 120 GROUND

DP185 Overview

Figure 15-3: Distribution Panel 185

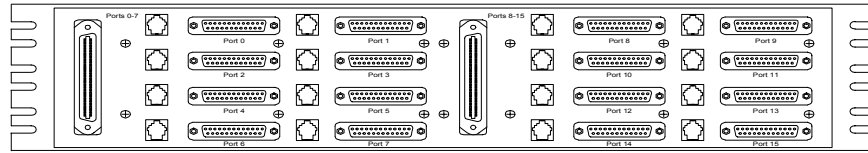

**Note:** For use with the AI185. Supports RS232 with RTS signal.

Table 15-4: DP185 Technical Specifications

<b>Mounting</b>	Available for 19-inch (48.26 cm) or 23-inch (58.42 cm) rack mounting unit		
<b>I/O Ports</b>	16 DB25/RJ11 connectors; Two 50-pin Telco connectors		
<b>Connector Pins</b>	<b>DB25</b>	<b>RJ11</b>	<b>Signal</b>
	2 20 4 3 6 7 1	4 3 6 2 1 5 -	TXD → DTR → RTS → RXD ← DSR ← SG FG
<b>Cables</b>	<ul style="list-style-type: none"> <li>● CAB50 - DP185 to AI185 (50-pin Telco connectors)</li> <li>● CAB157 - DP185 to network elements (DB25 connectors)</li> <li>● CAB115 - DP185 to AIRemote</li> </ul>		

## DP185B Overview

**Figure 15-4: Distribution Panel 185B**

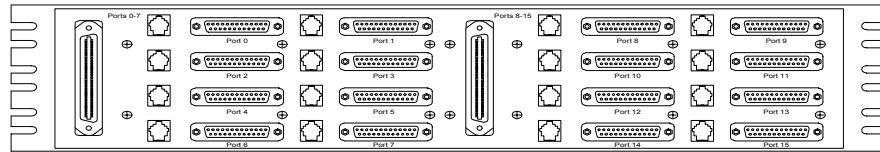

**Note:** For use with the AI185 Revision 5 only. Supports RS232 with DCD signal.

**Table 15-5: DP185B Technical Specifications**

<b>Mounting</b>	Available for 19-inch (48.26 cm) or 23-inch (58.42 cm) rack mounting unit		
<b>I/O Ports</b>	16 DB25/RJ11 connectors; Two 50-pin Telco connectors		
<b>Connector Pins</b>	<b>DB25</b>	<b>RJ11</b>	<b>Signal</b>
	2 20 8 3 6 7 1	4 3 6 2 1 5 -	TXD → DTR → DCD ← RXD ← DSR ← SG FG
<b>Cables</b>	<ul style="list-style-type: none"> <li>● CAB50 - DP185 to AI185 Revision 5 (50-pin Telco connectors)</li> <li>● CAB157 - DP185 to network elements (DB25 connectors)</li> <li>● CAB115 - DP185 to AIRemote</li> </ul>		



**DP185-RJ45  
Overview**

**Figure 15-5: Distribution Panel 185 RJ45**

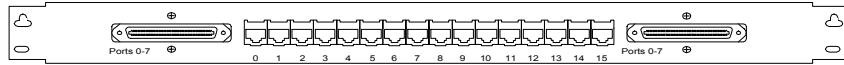

**Note:** For use with the AI185. Supports RS232 with RTS signal.

**Table 15-6: DP185-RJ45 Technical Specifications**

<b>Mounting</b>	Available for 19-inch (48.26 cm) or 23-inch (58.42 cm) rack mounting unit	
<b>I/O Ports</b>	16 RJ45 connectors; Two 50-pin Telco connectors	
<b>Connector Pins</b>	<b>RJ45</b>	<b>Signal</b>
	1 2 3 4 5 6 7 8	TXD → RXD ← RTS → DTR → DSR ← SG
<b>Cables</b>	<ul style="list-style-type: none"> <li>● CAB50 - DP185 to AI185 Revision 5 (50-pin Telco connectors)</li> <li>● Standard RJ45 cable - DP185 to network elements</li> </ul> <p>Example: CAB214 and CAB215</p>	

**DP194 Overview**      **Figure 15-6: Distribution Panel 194**



**Note:** For use with the AI194. Supports 10BaseT signal.

**Table 15-7: DP194 Technical Specifications**

<b>Mounting</b>	Available for 19-inch (48.26 cm) or 23-inch (58.42 cm) rack mounting unit	
<b>I/O Ports</b>	24 RJ45 connectors; Two 50-pin Telco connectors	
<b>Connector Pins</b>	<b>RJ45</b>	<b>Signal</b>
	1 2 3 4 5 6 7 8	TX+ TX- RX-  RX+
<b>Cables</b>	<ul style="list-style-type: none"> <li>● CAB170 (straight through cable) - AI194 (bottom) to DP194 (ports 1 to 12)</li> <li>● CAB180 (straight through cable) - AI194 (top) to DP194 (ports 13 to 24)</li> <li>● CAB156 - AI194 (bottom) to DP194 (ports 1 to 12)</li> <li>● CAB179 - AI194 (top) to DP194 (ports 13 to 24)</li> </ul>	

**DP196 Overview**      **Figure 15-7: Distribution Panel 196**

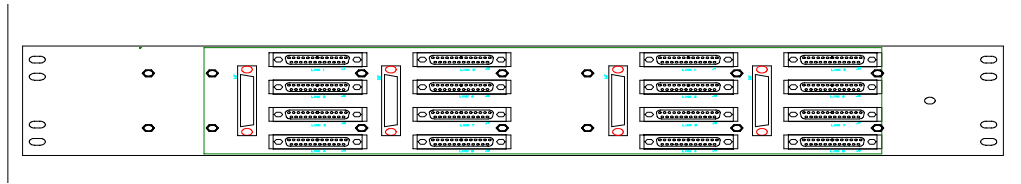

**Note:** For use with the AI196 cards. Supports RS232, RS530, and V.35 signals.

**Table 15-8: DP196 Technical Specifications**

<b>Mounting</b>	Available for 19-inch (48.26 cm) or 23-inch (58.42 cm) rack mounting unit	
<b>I/O Ports</b>	Four DB25 connectors	
<b>Connector Pins</b>	<b>DB25</b>	<b>Signal</b>
	1 2 3 4	The signal is dependent on the protocol.
<b>Cables</b>	<ul style="list-style-type: none"> <li>● CAB162S - AI196 to DP196</li> <li>● CAB157 - DP196 (DB25) to network elements (DB25 connectors)</li> </ul>	

**I709 Overview**

**Figure 15-8: Distribution Panel I709**

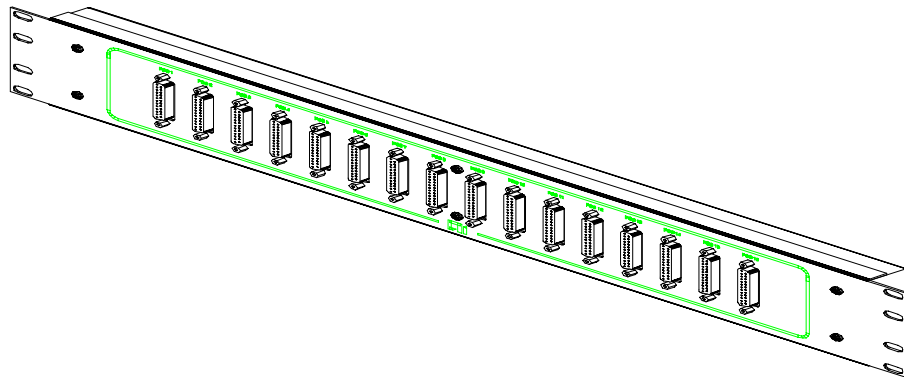

**Note:** This is a straight through patch panel. Used as a generic point of demarcation.

**Table 15-9: I709 Technical Specifications**

<b>Mounting</b>	Available for 23-inch (58.42 cm) rack mounting unit	
<b>I/O Ports</b>	16 DB25 connectors	
<b>Connector Pins</b>	<b>DB25</b>	<b>Signal</b>
	1 to 25	The application determines the signal.
<b>Cables</b>	<ul style="list-style-type: none"> <li>Any cable using a DB25 male connector</li> </ul>	

I711 Overview

Figure 15-9: Distribution Panel I711

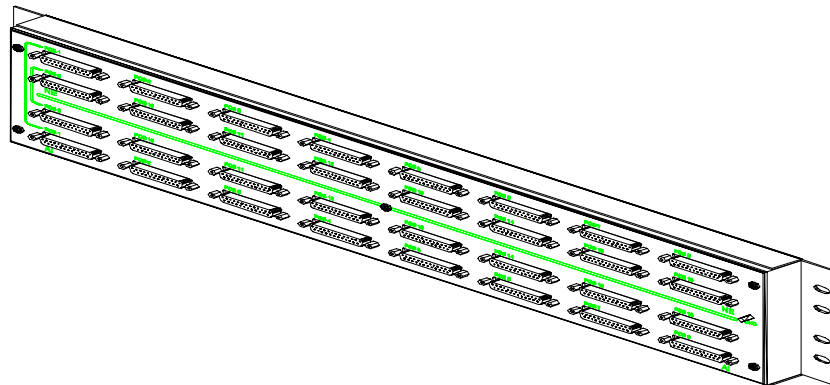

**Note:** The I711 is a patch through panel used as a generic point of demarcation.

Table 15-10: I711 Technical Specifications

<b>Mounting</b>	Available for 23-inch (58.42 cm) rack mounting unit	
<b>I/O Ports</b>	16 DB25 connectors	
<b>Connector Pins</b>	<b>DB25</b>	<b>Signal</b>
	1 to 25	The application determines the signal.
<b>Cables</b>	<ul style="list-style-type: none"> <li>Any cable using a DB25 male connector</li> </ul>	



# Appendix A: Static Electricity (ESD)

## Overview

Electrostatic discharge (ESD) has various sources. Walking across carpets, tiled floors, rolling on an office chair with polyurethane foam padding, and even just lifting envelopes off a workbench can all cause enough static discharge to damage electronic components.

The effects of ESD damage range from immediate board failure to sporadic field problems, erratic operation of components, and weakened parts that passed test inspections but fail early in field use.

ESD damage to electronic equipment, though not totally preventable, is minimized through precautionary handling of component parts.

[Table A-1](#) lists various static electricity voltages associated with ordinary activities at various humidity levels.

**Table A-1: Typical Electrostatic Voltages**

Static Source	Electrostatic Voltages	
	10-20% Relative Humidity	65-90% Relative Humidity
Walking across carpet	35,000	1,500
Walking over vinyl floor	12,000	250
Worker at bench	6,000	100
Handling vinyl envelopes for work instructions	7,000	600
Handling common poly bag picked up from bench	20,000	1,200
Work chair padded with polyurethane foam	18,000	1,500

[Table A-2](#) lists the static susceptibility threshold level of common semiconductor devices.

**Table A-2: Static Susceptibility Thresholds**

Device Type	Range of ESD Threshold Susceptibility (Volts)	
	Low	High
VMOS	30	1,800
MOSFET	100	200
GaAsFET	100	300
EPROM	100	
JFET	140	7,000
SAW	150	500
OP-AMP	190	2,500
CMOS (Input protected)	250	3,000
Schottky Diodes	300	2,500
Film resistors (thick, thin)	300	3,000
Bipolar transistors	380	7,000
ECL (PC board level)	500	
SCR	680	1,000
Schottky TTL	1,000	2,500



**Static Control**

Several steps can be taken to prevent damage to hardware from static electricity.

- Increase awareness of ESD.
- Increase inspection to locate damage to equipment from electrostatic discharges.
- Minimize handling of components.
- Increase testing before releasing parts.
- Remember that some devices can be damaged by static electricity even without touching them.
- Handle components in true, static shielding bags containing a highly conductive layer of protection. Pink, polyethylene bags may not be enough protection.
- Do not rely on topical antistatic sprays. They wear off and sometimes leave bare spots in the application.
- Wear a wrist strap.

## Wrist Strap Grounding

Anyone working on AI mounting rack equipment should be properly grounded using an anti-static wrist strap. The wrist strap is a mesh, elastic strap with a snap attachment. The snap attachment connects to a cord which has a banana plug or alligator clip at the end. The cord allows a ground connection to be made between a person and the frame ground of the rack system to equalize the potential for static shock.

The wrist strap diagram illustrates a wrist strap connected to the RDC180-C Common Alarm Panel which is mounted into the AI180 series chassis.

**Figure A-1: Anti-Static Wrist Strap Diagram**

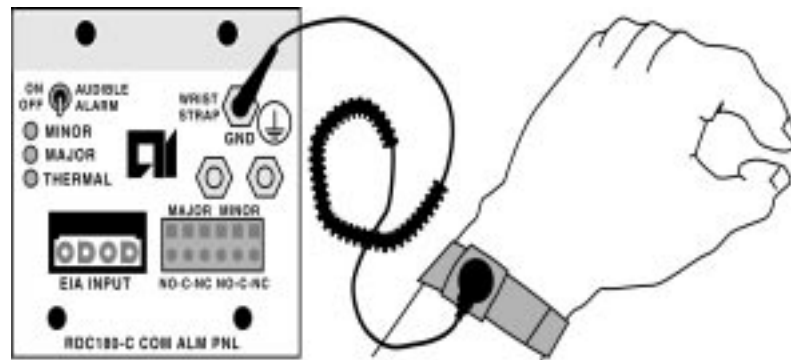

The frame ground of the rack system needs to be connected to a reliable earth groundpoint. If no attachment label identifies a connection point for the wrist strap plug, insert the banana plug end of the cord into any snug-fitting bare metal screw hole on the chassis or mounting rack frame to equalize the potential (static).

If a bay is not grounded properly, equalize the potential by holding onto the frame or chassis, or connect the banana plug end of the wrist strap cord into any snug-fitting bare metal screw hole on the mounting rack frame.

Alligator clips are available which fit the banana plug end of the wrist strap cord. The alligator clip can be attached to the center screw of any properly grounded AC electrical outlet to ground the person working on the equipment. The electrical outlet used must be the same outlet into which some component of the mounting rack is plugged.

When working on AI equipment in a central or remote office, and no wrist strap is available, hold onto the chassis with one hand while working with the other. This equalizes the potential between a person and the mounting rack frame.

Grounding can also be accomplished using a cord with an alligator clip at either end. Connect one alligator clip to the grounded mounting rack frame or center ground screw of any properly grounded AC electrical outlet and wrap the other end around the wrist and clip. Make sure the metal of the clip on the wrist is touching the skin.

## Setting Up Equipment/ Performing Maintenance



**Caution:** Before beginning the installation of any AI component, put on a grounded, anti-static wrist strap. Refer to the Wrist Strap Grounding section for more details about the grounding process.

The AI180switch contains electrostatic-sensitive components. Proper handling, shipping, and storage precautions must be exercised.

Removal and installation of circuit boards must be performed in a static-free environment. This means a technician should wear an anti-static wrist strip and stand on an anti-static mat. Both the wrist strap and mat must be grounded at the same point as the AISwitch enclosure. Refer to the Wrist Strap Grounding section for more details about the grounding process.

When not in use, circuit boards must be kept in their anti-static plastic bags. Circuit boards must only be removed from their anti-static plastic bags immediately prior to installation into the AISwitch enclosure. Immediately upon removal from the enclosure, circuit boards must be inserted into their anti-static bags.

Do not ship or store the electronic circuit boards near strong electrostatic, electromagnetic, magnetic, or radioactive fields.

If the mounting rack has not been assembled by the factory, unpack the enclosures and cards with care, placing them on a clear, grounded work area. Inside the packaging, find the rack mounting brackets and the power cord (if your system operates on AC power). Assemble the mounting rack and begin placing the components where needed for the particular application.

To install or adjust the settings of any of the components in the rack system, refer to the procedure for installing AISwitch hardware components as described in the installation chapter for each separate component. If unfamiliar with the switching system, proceed to the appropriate step for a specific component in the installation instructions.

If installing the enclosure that contains the system's controller or a new expander enclosure on a previously established configuration, or additional interface cards, refer to the Installing or Replacing Network Interface Cards and the Installing or Replacing the Series AI180 chassis chapters for more details.

If two chassis are mounted in the same rack, make sure that the supplied grounding cables are installed between all of the system components. Refer to the Installing or Replacing the Series AI180 chassis chapter for more details regarding the installation of the expander chassis. Applied Innovation Inc. supports the use of only one expander chassis in a single mounting rack frame.



# Appendix B: Calculating Chassis Power Consumption

## Overview

The AISwitch Series 180 power supplies in the chassis provide power to each component through the backplane. Determining which power supply is best for the telecommunication facility requires knowing how much power is needed for the chassis components.

The power consumption of each component within a chassis must be considered separately, then totalled according to how the chassis is configured. See the [Shorthand Calculation Method](#) and the [Input Amps/Watts Calculation Method](#) to calculate the power needs of the chassis.

## Power Supplies Available

**Table B-1: Power Supplies Available**

Power Supply	When Required	Fusing
RDC180-P	If the internal DC power demand is less than 14.9 amps	5 amp or 7.5 amp fusing
RDC180-HP	If the internal DC power demand is greater than 14.9 amps	One 15-amp fuse, one 10-amp fuse, and two 2-amp fuses
AI325-AC	When AC power is used	

## Internal Power Ratings

Each card in an AI180 has an internal power rating. This rating is in Amps, and is computed from the 5 volt feed on the power buss. There is also a 12 volt power rating, but the current consumption drawn from the 12 volt source is too small to be a factor in the calculation of the total power consumption of a loaded enclosure.

The Module Internal Power Ratings table lists the power consumption of the currently supported AI cards.

**Table B-2: Module Internal Power Ratings**

Module	Power Rating in Amps
AI120 contact closure monitoring system (CCMS) card	0.1125
AI180 chassis and backplane	1.2
AI183 4-port async card	0.5
AI185 16-port async card	1.6
AI192 X.25 card with interface	1.6
AI193-ES OSI gateway card	2.0
AI193-FT OSI gateway card	2.1
AI193-TX TCP/IP gateway card	1.7
AI194 24-port Ethernet hub card	2.2
AI196-X 16-port X.25 card	3.1
AI196-I 16-port multi-protocol card	3.1
AI196-IEGB 16-port TBOS to TTL1 translation card	3.1
AI198 CLC	2.2
AI285	2.6
AI294 8-port switching hub card (10-Base-T and Fiber interface daughter card)	5.2
AI294 8-port switching hub card (10-Base-T daughter card only)	4.2
AI296	2.8
AI2524 router card	2.0

Power consumption of the total chassis can be calculated using a shorthand method, or an input Amps/Watts method.

## Power Consumption Calculation

### Shorthand Calculation Method

This shorthand method to calculate power consumption gives you an assessment of system power needs, but does not give actual total current draw on the input. To calculate total input current draw or system dissipation, you must use the input Amps/Watts method.

You must use this shorthand method to determine if your desired chassis configuration can operate with a legacy RDC180-P power supply. Any configuration which uses more than four AI196-I cards must use the RDC180-HP power supply.

To calculate the overall internal power rating for a given system, total up the power ratings for all modules.

**Table B-3: Power Consumption Shorthand Method Example 1:**

Component	Quantity	Amps Per Component	Total Amps
180 chassis backplane	1	1.2	1.2
AI198 CLC	2	2.2	4.4
AI185	1	1.6	1.6
AI294	1	5.2	5.2
AI2524	1	1.3	1.3
AI196-I	5	3.6	18
Total:			31.7

In this example, the chassis power rating totals 31.7 Amps. Therefore, this system requires a 300 Watt RDC180-HP power source since the total is above 14.9 Amps.

**Table B-4: Power Consumption Shorthand Method Example 2:**

Component	Quantity	Amps Per Component	Total Amps
180 chassis backplane	1	1.2	1.2
AI198 CLC	1	2.2	2.2
AI185	1	1.6	1.6
AI193-TX	1	1.7	1.7
AI196-I	2	3.6	7.2
Total:			13.9

In this example, the chassis power rating totals 13.9 Amps. Therefore, this system can use the RDC180-P power source since the total is below 14.9 Amps.

### Input Amps/Watts Calculation Method

The input amps/watts method utilizes the calculations of the shorthand method in more precise equations and adds in a safety factor. The approximate current draw and total power dissipation is calculated using the following steps:

1. Use the shorthand method to determine the overall internal power rating for the system
2. Translate the internal power rating to Watts (based on the 5 Volt supply) using the internal power rating to watts formula.
3. Use low line, normal, and high line input voltage values to calculate the system current draw for various line conditions. Use the low line current draw, normal line current draw, and high line current draw formulas.
4. Add in a 70% safety factor using the safety factor formula.

### Internal Power Rating to Watts Formula

This formula is used to convert the internal power rating from Volts to Watts.

$$\text{TPR} \times 5 \text{ volts} / 42.5 \text{ volts} = \text{IPRW}$$

where the members of the equation are defined as:

TPR                    total of the input power ratings

IPRW                  input power rating in Watts



### Low Line Current Draw Formula

This formula is used to calculate the low line current draw.

$$\text{IPRW} / 42.5 \text{ volts} = \text{LLCD}$$

where the members of the equation are defined as:

IPRW            input power rating in Watts  
 LLCD            low line current draw

### Normal Current Draw Formula

This formula is used to calculate the normal line current draw.

$$\text{IPRW} / 48 \text{ volts} = \text{NCD}$$

where the members of the equation are defined as:

IPRW            input power rating in Watts  
 NCD            normal current draw

### High Line Current Draw Formula

This formula is used to calculate the high line current draw.

$$\text{IPRW} / 56.5 \text{ volts} = \text{HLCD}$$

where the members of the equation are defined as:

IPRW            input power rating in Watts  
 HLCD            high line current draw

### Safety Factor Formula

Once the current draw is calculated, add in the safety factor using the formula:

$$(\text{CD} * 0.70) + \text{CD} = \text{CDS}$$

where the members of the equation are defined as:

CD                current draw  
 CDS                current draw with safety factor included

**Table B-5: Input Amps/Watts Calculation Method Example 1:**

Component	Quantity	Amps Per Component	Total Amps
180 chassis backplane	1	1.2	1.2
AI198 CLC	2	2.2	4.4
AI185	1	1.6	1.6
AI294	1	5.2	5.2
AI2524	1	1.3	1.3
AI196-I	5	3.6	18
Total:			31.7

In this example, the chassis power rating totals 31.7 Amps.

Use the internal power rating conversion to watts formula.

$$\frac{31.7 \times 5 \text{ volts}}{42.5 \text{ volts}} = 227.4 \text{ total input watts}$$

To calculate the line voltage range, use the low, normal, and high line current draw formulas.

$$227.4 / 42.5 \text{ volts} = 5.35$$

$$227.4 / 48 \text{ volts} = 4.74$$

$$227.4 / 56.5 \text{ volts} = 4.02$$

Calculate your safety factor for each of the voltages in the range.

$$(5.35 * 0.70) + 5.35 = 9.115 \text{ Amps at low line voltage}$$

$$(4.74 * 0.70) + 4.74 = 8.06 \text{ Amps at normal line voltage}$$

$$(4.02 * 0.70) + 4.02 = 6.834 \text{ Amps at high line voltage}$$

## Free Manuals Download Website

<http://myh66.com>

<http://usermanuals.us>

<http://www.somanuals.com>

<http://www.4manuals.cc>

<http://www.manual-lib.com>

<http://www.404manual.com>

<http://www.luxmanual.com>

<http://aubethermostatmanual.com>

Golf course search by state

<http://golfingnear.com>

Email search by domain

<http://emailbydomain.com>

Auto manuals search

<http://auto.somanuals.com>

TV manuals search

<http://tv.somanuals.com>