

# DELTA<sup>®</sup>

POWER EQUIPMENT CORPORATION

## 10-INCH PORTABLE CONTRACTOR TABLE SAW

SCIE SUR TABLE PORTABLE CONTRACTOR DE 10 PO  
SIERRA DE MESA DE CONTRATISTA PORTÁTIL DE 10  
PULGADAS

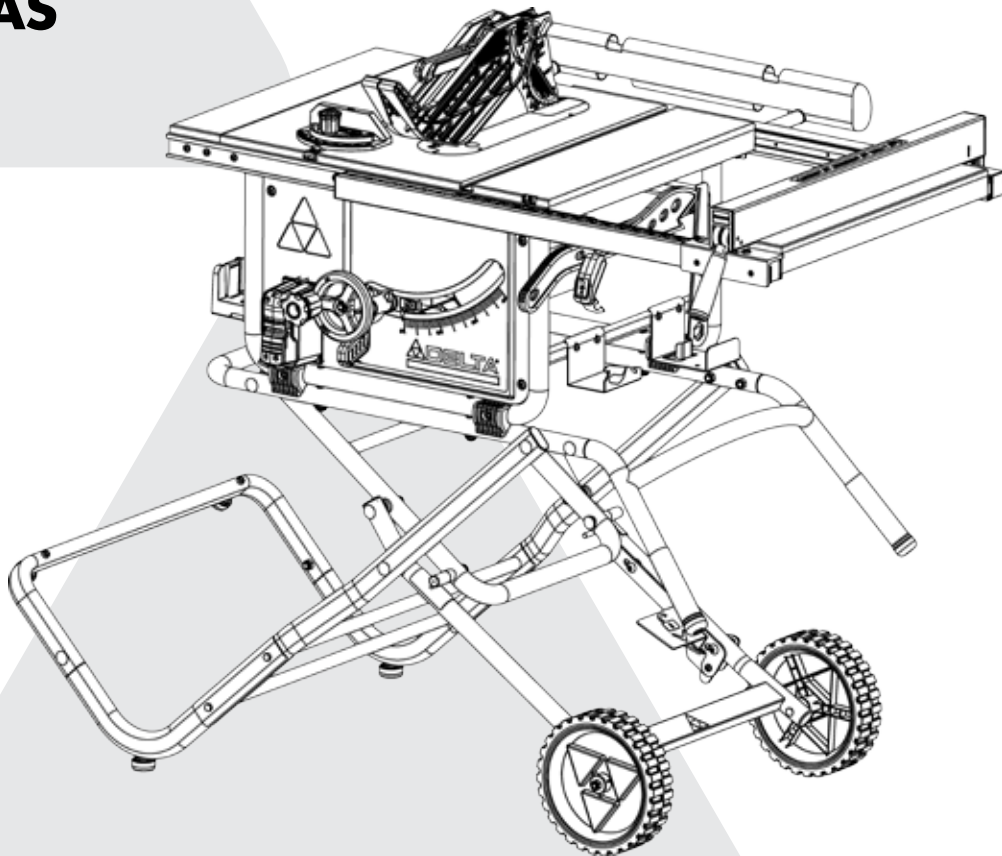

Français (36)

Español (70)

[www.DeltaMachinery.com](http://www.DeltaMachinery.com)

Instruction Manual

# 36-6022

**⚠ WARNING:** To reduce the risk of serious injury, thoroughly read and comply with all warnings and instructions in this manual and on product.  
**KEEP THIS MANUAL NEAR YOUR PRODUCT FOR EASY REFERENCE AND TO INSTRUCT OTHERS**



# TABLE OF CONTENTS

<b>FUNCTIONAL DESCRIPTION</b> .....	2	TRANSPORTING THE SAW .....	28
<b>IMPORTANT SAFETY INSTRUCTIONS</b> .....	3	<b>MAKING CUTS</b> .....	<b>29</b>
<b>SAFETY-SYMBOLS-DEFINITIONS</b> .....	3	RIP CUTS .....	30
<b>GENERAL SAFETY RULES</b> .....	3	BEVEL RIPPING .....	30
<b>PROPOSITION 65 WARNING</b> .....	4	CROSSCUTTING .....	31
<b>TABLE SAW SAFETY RULES</b> .....	5	BEVEL CROSSCUTTING .....	31
TERMINOLOGY.....	5	MITER CUTS .....	31
GENERAL POWER TOOL SAFETY.....	5	COMPOUND MITER CUTS.....	32
SAW BLADE GUARD, ANTI-KICKBACK PAWLS AND		LARGE PANEL CUTS.....	32
RIVING KNIFE ASSEMBLY.....	6	NON-THROUGH CUTS.....	32
MAKING A PUSH STICK.....	6	MAKING A NON-THROUGH CUT .....	32
KICKBACKS .....	7	MAKING A DADO CUT .....	33
<b>POWER CONNECTIONS</b> .....	8	<b>CUTTING AIDS AND ACCESSORIES</b> .....	<b>33</b>
POWER SOURCE .....	8	PUSH STICK .....	33
EXTENSION CORDS.....	8	AUXILIARY MITER GAUGE FACING.....	34
<b>UNPACKING</b> .....	9	PUSH BLOCK.....	34
PACKAGE CONTENTS .....	9	FEATHERBOARD .....	35
CONTENTS OF HARDWARE BAGS.....	10	CUT OFF GAUGE.....	35
<b>ASSMEBLY</b> .....	10	JIGS .....	35
ASSEMBLING UPPER STAND.....	11	<b>MAKING ADJUSTMENTS</b> .....	<b>36</b>
ASSEMBLING THE STAND.....	12	LEVELING THE THROAT PLATE.....	36
WHEELS .....	13	SQUARING THE BLADE VERTICALLY TO THE TABLE ...	36
PEDAL ASSEMBLY .....	14	ADJUSTING THE BEVEL STOPS .....	37
UPPER STAND ASSEMBLY .....	16	ADJUSTING THE BLADE HEIGHT.....	38
ATTACH SAW TO STAND ASSEMBLY.....	18	CHANGING THE BEVEL .....	38
HEIGHT ADJUSTMENT KNOB INSTALLATION .....	19	USING THE MITER GAUGE.....	39
BLADE AND GUARDS .....	19	USING THE OUTFEED SUPPORT.....	39
ATTACH THE BLADE.....	19	USING THE RIGHT HAND TABLE EXTENSION .....	40
INSERT THROAT PLATE .....	21	RIP FENCE ADJUSTMENTS.....	40
ANTI-KICKBACKS PAWLS AND BLADE GUARD .....	23	<b>RIVING KNIFE POSITION AND ALIGNMENT</b> .....	<b>42</b>
OUTFEED SUPPORT STOPS .....	24	LOWERING RIVING KNIFE .....	42
ONBOARD STORAGE.....	26	RIVING KNIFE ALIGNMENT.....	43
<b>OPERATION</b> .....	27	<b>MAINTENANCE</b> .....	<b>45</b>
TURNING THE SAW ON/OFF .....	28	<b>TROUBLESHOOTING</b> .....	<b>45</b>
		<b>ACCESSORIES</b> .....	<b>45</b>
		<b>WARRANTY</b> .....	<b>46</b>
		<b>FRENCH</b> .....	<b>47</b>
		<b>SPANISH</b> .....	<b>93</b>

## FUNCTIONAL DESCRIPTION

The DELTA® #36-6022 series 10-inch Contractor Table Saw is designed for portability and high quality performance. It includes: basic machine, sturdy tubular steel stand, integral 2 1/2" dust chute, a T-squared fence system, T-slot miter gauge, 15-amp motor, on/off switch, cast aluminum table, extension wing, see-through blade guard with anti-kickback fingers, and 10-inch carbide blade.

## SPECIFICATIONS

Max depth of cut at 90 degrees:	3-1/2"
Max depth of cut at 45 degrees:	2-1/2"
Max rip to right of blade:	30"
Max rip to left of blade:	12"
Max width of dado:	13/16" x 8 dia.
<b>MOTOR SPECIFICATIONS</b>	
Amps	15 Amps
VOLTAGE	120 Volts

**NOTICE:** The manual cover illustrates the current production model. All other illustrations contained in the manual are representative only and may not be exact depictions of the actual labeling or accessories included. They are intended for illustrative purposes only.

# IMPORTANT SAFETY INSTRUCTIONS



**⚠ WARNING:** CAREFULLY READ AND FOLLOW ALL WARNINGS AND INSTRUCTIONS ON YOUR PRODUCT AND IN THIS MANUAL. SAVE THIS MANUAL. MAKE SURE ALL USERS ARE FAMILIAR WITH ITS WARNINGS AND INSTRUCTIONS WHEN USING THE TOOL. Improper operation, maintenance or modification of tools or equipment could result in serious injury and/or property damage.

## SAFETY SYMBOLS- DEFINITIONS

This manual contains information that is important for you to know and understand. This information relates to protecting YOUR SAFETY and PREVENTING EQUIPMENT PROBLEMS. To help you recognize this information, we use the symbols below. Please read the manual and pay attention to these sections.

**⚠ DANGER:** Indicates an imminently hazardous situation which, if not avoided, will result in death or serious injury.

**⚠ WARNING:** Indicates a potentially hazardous situation which, if not avoided, could result in death or serious injury.

**⚠ CAUTION:** Indicates a potentially hazardous situation which, if not avoided, may result in minor or moderate injury.

**CAUTION** Used without the safety alert symbol indicates potentially hazardous situation which, if not avoided, may result in property damage.

## GENERAL SAFETY RULES

**⚠ WARNING:** FAILURE TO FOLLOW THESE RULES MAY RESULT IN SERIOUS PERSONAL INJURY.

- **READ INSTRUCTION MANUAL AND KNOW YOUR TOOL.** Read and familiarize yourself with the entire instruction manual. Learning the tool's proper applications, limitation, and specific potential hazards will greatly minimize the possibility of accidents and injury. Make sure all users are familiar with its warnings and instructions before using.
- **MAINTAIN TOOLS WITH CARE.** Keep tools sharp and clean for best and safest performance. Follow instructions for lubricating and changing accessories.
- **KEEP GUARDS AND SAFETY DEVICES IN PLACE and working properly.**
- **CHECK TOOLS FOR DAMAGE.** Before using, and after tool or accessory has been dropped or damaged, check guards and affected parts, for alignment, breakage and any other condition that may affect its operation to make sure tool will operate properly and all parts will perform their intended function. Do not use a damaged product. A guard or any other part that is damaged should be properly repaired or replaced using factory approved service parts.
- **NEVER STAND ON TOOL.** Serious injury could occur if the tool tips or if you unintentionally contact the cutting surface.
- **WEAR PROPER APPAREL.** Do not wear loose clothing, gloves, neckties, rings, bracelets, or other jewelry which may get caught in moving parts. Nonslip protective footwear is recommended. Wear protective hair covering to contain long hair.
- **WEAR PROPER EYE PROTECTION.** All persons in work area should wear safety glasses with side shields. Everyday eye glasses with impact resistant lenses are not safety glasses. Eye equipment should comply with ANSI Z87.1 standards.
- **WEAR PROPER HEARING PROTECTION.** All people in work area should wear proper hearing protection consistent with noise levels and exposure. Hearing equipment should comply with ANSI S3.19 standards.
- **DUST PROTECTION.** Use of power tools can generate and/or disburse dust, which may cause serious or permanent respiratory or other injury, including silicosis (a serious lung disease), cancer, and death. Direct particles away from face and body. Always operate tool in a well-ventilated area and provide for proper dust removal. Use dust collection system whenever possible. Avoid breathing dust and avoid prolonged contact with dust. Allowing dust to get into your mouth or eyes, or lay on your skin may promote absorption of harmful material. Use properly fitting NIOSH/OSHA approved respiratory protection appropriate for the dust exposure and wash exposed areas with soap and water.
- **LOCK TOOLS AND WORK AREA.** Use padlocks, and master switches, or remove and store starter keys to prevent operation by children and other unauthorized users.
- **DO NOT USE OR STORE TOOL IN DANGEROUS ENVIRONMENTS.** Exposure to rain and damp or wet locations can result in shock or electrocution, or damage the tool. Do not operate electric tools near flammable liquids or in gaseous or explosive atmospheres. Motors and switches in these tools may spark and ignite fumes.
- **KEEP WORK AREA CLEAN AND WELL LIT.** Cluttered and poorly-lit work areas, surfaces and benches can lead to accidents.

## GENERAL SAFETY RULES (CONTINUED)

- **KEEP CHILDREN AND BYSTANDERS AWAY** from work area.
- **USE RECOMMENDED ACCESSORIES.** Consult manual for recommended accessories. Use of inappropriate accessories may cause personal injury or property damage.
- **DISCONNECT TOOL** from power source before servicing, adjusting or changing set-ups or blades, bits, cutters and other accessories.
- **TO REDUCE RISK OF ACCIDENTAL STARTING** make sure power switches are in “OFF” position before plugging tool in.
- **TO REDUCE THE RISK OF ELECTRIC SHOCK,** this equipment has a polarized plug (one blade is wider than the other). This plug will fit in a polarized outlet only one way. If the plug does not fit fully in the outlet, reverse the plug. If it still does not fit, contact a qualified electrician to install the proper outlet. Do not change the plug in any way.
- **DO NOT** touch the plug’s metal prongs when unplugging or plugging in the cord.
- **USE PROPER EXTENSION CORD.** If you use an extension cord, make sure it is in good condition and heavy enough to carry the current your product will draw. An undersized cord will cause a drop in line voltage, resulting in loss of power and overheating. See Extension Cord Chart for correct size depending on cord length and data plate ampere rating. If in doubt, use the next smaller gauge number. The smaller the gauge number, the heavier the cord. When working outside, make sure the extension cord is rated for outdoor use. Consult power connection section of this manual for Extension Cord Chart and power connection safety.
- **DO NOT ABUSE POWER CORDS. NEVER** yank cord to disconnect from receptacle, crush cord, or expose it to heat, oil or sharp objects.
- **USE PROPER TOOL.** Do not force tool to do a task for which it was not designed.
- **SECURE WORKPIECE.** Use clamps or a vise to hold the workpiece when practical. It is safer than using your hands and frees both hands to operate tool.
- **REMOVE ADJUSTING KEYS AND WRENCHES.** Form habit of checking to see that all adjusting keys and wrenches are removed before starting tool.
- **STAY ALERT, WATCH WHAT YOU ARE DOING, AND USE COMMON SENSE.** Do not use power tools when tired or under the influence of drugs, alcohol, or medication. A moment of inattention while operating power tools may result in injury.
- **USE PROPER FEED DIRECTION.** Feed workpiece against the direction of rotation of the tool’s blade, cutter, or abrasive surface. Feeding in the other direction may cause the workpiece to be thrown at high speed.
- **DO NOT OVERREACH.** Keep proper footing and balance to maintain control.
- **DO NOT FORCE TOOL OR WORKPIECE.** Operate tool at intended speed and feed rate for better and safer operation.
- **NEVER LEAVE TOOL RUNNING UNATTENDED. TURN POWER OFF.** Do not leave tool until it comes to a complete stop. In the event of a power failure, move switch to “OFF” position.
- **SERVICE PARTS.** Use only identical replacement parts when servicing your tool.

## PROPOSITION 65 WARNING:

**▲ WARNING:** Dust created by power sanding, sawing, grinding, drilling, and other construction activities may contain chemicals known to the state of California to cause cancer, birth defects or other reproductive harm. Some examples are:

- Lead from lead-based paints
  - Crystalline silica from bricks and cement and other masonry products
  - Asbestos dust
  - Arsenic and chromium from chemically-treated lumber
- Your risk from these exposures varies depending on how often you do this type of work. To reduce your exposure to these chemicals: work in a well-ventilated area and work with approved safety equipment, such as dust masks that are specifically designed to filter out microscopic particles.
  - Avoid prolonged contact with dust from power sanding, sawing, grinding, drilling, and other construction activities. Wear protective clothing and wash exposed areas with soap and water

If you have any questions or concerns relative to the use of your tool or the contents of this manual, stop using the tool and call DELTA® Customer Care at 1-800-223-7278.

## SAVE THESE INSTRUCTIONS.

Refer to them often and use them to instruct others.

If tool is loaned to someone, also loan them these instructions.

# TABLE SAW SAFETY RULES

## TERMINOLOGY

The following terms will be used throughout the manual and you should become familiar with them.

- Through-cut - any cut that completely cuts through the workpiece.
- Non-through cut - any cut that does not completely cut through the workpiece.
- Push stick - a wooden or plastic stick, usually homemade, that is used to push a small workpiece through the saw and keeps the operator's hands clear of the blade.
- Kickback - when the saw blade binds in the cut or the workpiece binds between the blade and the fence and the workpiece is thrust back toward the operator.
- Freehand - cutting without the use of a miter gauge or rip fence or any other means of guiding or holding the workpiece other than the operator's hand.
- Plunge cutting - blind cuts in the workpiece made by either raising the blade through the workpiece or lowering the workpiece down to the blade.
- Re-sawing - flipping the workpiece to complete a cut the saw is not capable of making in one pass.
- Cove cutting - an operation where the work is fed at an angle across the blade. (Also known as "coving")

**▲ WARNING: FAILURE TO FOLLOW THESE RULES MAY RESULT IN SERIOUS PERSONAL INJURY.**

- **SEE GENERAL POWER TOOL SAFETY SECTION OF THIS MANUAL.** Read entire instruction manual before operating saw. Learning the saw's proper applications, limitations, and specific potential hazards will greatly minimize the possibility of accidents and injury. Make sure all users are familiar with its warnings and instructions before using saw.
- **SEE POWER CONNECTION SECTION OF THIS MANUAL** for instructions and warnings regarding power cords and connections.

## GENERAL POWER TOOL SAFETY

- **AVOID KICKBACK.** Pay particular attention to the instructions (below) for reducing risk of kickback.
- **OBTAIN ADVICE** from your supervisor, instructor, or another qualified person if you are not thoroughly familiar with the operation of this machine. Knowledge is safety.
- **DRESS PROPERLY.** Wear appropriate apparel, eye protection, hearing protection and dust protection as specified in the General Power Tool Safety Section of this manual.
- **PROPER ASSEMBLY.** Do not operate this saw until it is completely assembled and installed according to the instructions.
- **STABILITY.** Make sure table saw is properly assembled and located on a stable surface before use to keep saw from moving during cut. Do not attempt the substitute a table or other surface for the leg assembly.
- **USE CORRECT BLADE AND RIVING KNIFE** for the intended operation. The blade must be installed so the points of the teeth are pointing toward the front of the saw. Do not use oversized blade or blade with incorrect arbor opening. Always tighten the blade arbor nut securely. Before use, inspect the blade for cracks or missing teeth. Do not use a damaged or dull blade. Always use blade within the thickness range for which the riving knife is designed.
- **USE PROPER THROAT PLATE.** The proper throat plate must be in place and properly secured at all times to reduce the risk of a thrown workpiece and possible injury.
- **USE SAW BLADE GUARD, RIVING KNIFE AND ANTI-KICKBACK PAWLS.** Your saw is equipped with a modular blade guard, riving knife and anti-kickback pawl assembly, each component of which should be used for every possible operation, including all through cuts. This assembly is discussed in more detail below. Make sure components are securely installed prior to operation.
- **NEVER CUT METALS, CEMENT BOARD OR MASONRY.** Certain man-made materials have special instructions for cutting on table saws. Follow the manufacturer's recommendations at all times.
- **SUPPORT YOUR WORKPIECE** based on its size and the type of operation to be performed. Hold the workpiece firmly against the fence and down against the table surface. Do not leave a wide panel or long board (or other large workpiece) unsupported – the weight of the workpiece may cause it to shift on the table resulting in loss of control.
- **NEVER PERFORM LAYOUT, ASSEMBLY OR SET-UP WORK ON THE TABLE/WORK AREA** when the saw is running.
- **USE A PUSH STICK** that is appropriate to the application to push and hold down a workpiece through the completion of the cut. A push stick is a wooden or plastic stick, usually homemade, that should be used whenever the size or shape of the workpiece would cause you to place your hands within 6 in. (152 mm) of the blade. Instructions for making a push stick are included in this manual. A push stick is also provided with this saw.
- **NEVER** Perform freehand cutting, plunge cutting, re-sawing, or cove cutting.
- **CHECK WORKPIECE AND SET-UP** before each operation. Knots, irregularities, or nails in workpiece and positioning mistakes or incomplete set-up may interfere with or affect saw performance and personal safety.
- **NO FREEHAND CUTS.** Always use a rip fence, miter gauge, or other appropriate devices to guide or hold down the workpiece. Use hold-downs, jigs, fixtures or feather boards to help guide and control The workpiece. Accessories for use with your saw

# TABLE SAW SAFETY RULES

are available at extra cost from your local dealer or authorized service center.

- **DO NOT USE RIP FENCE AND MITER GAUGE AT THE SAME TIME.**
- **AVOID AWKWARD OPERATIONS AND HAND POSITIONS** where a sudden slip could cause a hand to move into a saw blade. Operate with table at or near waist level for maximum balance and control. Anticipate effect of workpiece size on your ability to adjust position and maintain control through completion of cut.
- **KEEP ARMS, HANDS AND FINGERS AT LEAST SIX INCHES AWAY FROM THE BLADE.**
- **KEEP HANDS AND OTHER BODY PARTS OUT OF THE BLADE PATH. NEVER** have any part of your body in line with the path of the saw blade.
- **NEVER START THE MACHINE WITH THE WORKPIECE AGAINST THE BLADE** to reduce the

risk of a thrown workpiece.

- **DO NOT REACH OVER/REACH AROUND.** Never reach over, in back of, or around the cutting tool with either hand while the blade is in motion.
- **NEVER ATTEMPT TO FREE A STALLED BLADE OR TRAPPED WORKPIECE** without first turning the machine off and disconnecting the saw from the power source.
- **BEFORE LEAVING THE SAW,** wait for the blade to come to a complete stop, then disconnect from the power source, clean the table and work area, and lock out switch to prevent unauthorized use.
- **AN UNFAMILIAR NOISE OR EXCESSIVE VIBRATION** may indicate a problem with your saw. If this happens, turn it off and disconnect it from the power source until the problem has been located and corrected. Contact customer service for assistance if the problem cannot be solved.

## SAW BLADE GUARD, ANTI-KICKBACK PAWLS AND RIVING KNIFE ASSEMBLY

Your table saw is equipped with a blade guard, anti-kickback pawls and riving knife assembly that covers the blade and reduces the possibility of accidental blade contact. The riving knife is a flat plate that fits into the cut made by the saw blade and effectively Figurehts kickback by lessening the tendency of the blade to bind in the cut. Two anti-kickback pawls are located on the sides of the riving knife that allow the wood to pass through the blade in the cutting direction but reduce the possibility of the material being thrown backwards toward the operator. The blade guard and anti-kickback pawls can only be used when making through cuts that sever the wood. When making rabbets and other non-through cuts, the blade guard and anti-kickback pawls must be removed

and riving knife lowered to the non-through cut position marked on the riving knife.

Use all components of the guarding system (blade guard assembly, riving knife and anti-kickback pawls) for every operation for which they can be used including all through-cutting. If you elect not to use any of these components for a particular application, exercise additional caution regarding control of the workpiece, the use of push sticks, the position of your hands relative to the blade, the use of safety glasses, the means to avoid kickback and all other warnings contained in this manual and on the saw itself. Replace the guarding systems as soon as you return to through-cutting operations. Keep the guard assembly in working order.

## MAKING A PUSH STICK

In order to operate your table saw safely, you must use a push stick whenever the size or shape of the workpiece would otherwise cause your hands to be within 6 inches (152 mm) of the saw blade or other cutter. A push stick is included with this saw.

No special wood is needed to make additional push sticks as long as they are sturdy and long enough and the wood is free of knots, checks and cracks. A length of 16 inches (400 mm) is recommended with a notch that fits against the edge of the workpiece to prevent slipping.

It's a good idea to have several push sticks of the same minimum length, 16 inches (400 mm), with different size notches for different workpiece thicknesses.

The shape can vary to suit your own needs as long as it performs its intended function of keeping your hands away from the blade. Angling the notch so the push stick can be held at a 20- to 30-degree angle from the saw's table will help you to hold down the workpiece while also moving it through the saw. Refer to diagram in cutting aids section on page 26 of this manual.

# TABLE SAW SAFETY RULES

## KICKBACKS

Kickbacks can cause serious injury. A kickback occurs when a part of the workpiece binds between the saw blade and the rip fence, or other fixed object, and rises from the table and is thrown toward the operator. The risk of kickback can be minimized by attention to the following instructions.

### HOW TO REDUCE THE RISK OF KICKBACKS AND PROTECT YOURSELF FROM POSSIBLE INJURY:

- Be certain that the rip fence is parallel to the saw blade.
- **DO NOT** rip by applying the feed force to the section of the workpiece that will become the cut-off (free) piece. Feed force when ripping should always be applied between the saw blade and the fence; use a push stick for all narrow work that is 6 inches (152 mm) wide or less.
- Keep saw blade guard, riving knife and anti-kickback assembly in place and operating properly. The riving knife must be in alignment with the saw blade and the anti-kickback assembly must stop a kickback once it has started. Check their action before ripping by pushing the wood under the anti-kickback assembly. The teeth must prevent the wood from being pulled toward the front of the saw. If any part of assembly is not operational, return to the nearest authorized service center for repair.
- Plastic and composite materials (like hardboard) may be cut on your saw. However, since these are usually quite hard and slippery, the anti-kickback pawls may not stop a kickback. Therefore, be especially attentive to following proper set up and cutting procedures for ripping.
- Use saw blade guard, anti-kickback pawls, and riving knife assembly for every possible operation, including all through-cut sawing.
- Push the workpiece past the saw blade prior to releasing control.
- **NEVER** rip a workpiece that is twisted or warped, or does not have a straight edge to guide along the fence.
- **NEVER** saw a large workpiece that cannot be controlled.
- **NEVER** use the fence as a guide or length stop when crosscutting.
- **NEVER** saw a workpiece with loose knots, flaws, nails or other foreign objects.
- **NEVER** rip a workpiece shorter than 10 inches (254 mm).
- **NEVER** use a dull blade. A dull blade should be replaced or re-sharpened.

# POWER CONNECTIONS

## POWER SOURCE

This saw is equipped with a 15-amp motor for use with a 120-volt, 60-HZ alternating current. See instructions below regarding proper connections for your saw.

For voltage, the wiring in a shop is as important as the motor's rating. A line intended only for lights may not be able to properly carry the current needed for a power tool motor; wire that is heavy enough for a short distance may be too light for a greater distance; and a line that can support one power tool may not be able to support two or three.

A separate electrical circuit should be used for your machines. This circuit should not be less than #12 wire and should be protected with a 20-amp time lag fuse. Before connecting the machine to the power line, make sure the switch is in the "OFF" position and be sure that the electric current is of the same characteristics as indicated on the machine. A substantial voltage drop will cause a loss of power and overheat the motor. It may also damage the machine.

**⚠ DANGER:** DO NOT EXPOSE THE MACHINE TO RAIN OR OPERATE THE MACHINE IN DAMP LOCATIONS.

## EXTENSION CORDS

**⚠ DANGER:** Never use a damaged extension cord. Check extension cords before each use. If damaged, replace immediately. Touching the damaged area could cause electrical shock resulting in serious injury.

**⚠ CAUTION:** Keep the extension cord clear of the work area. Position the cord so it will not get caught on lumber, tools or other obstructions.

- Use proper extension cords. When using an extension cord, be sure to use one heavy enough to carry the current machine. An undersized cord will cause a drop in line voltage, resulting in loss of power and overheating. The table shows the maximum gauge to use depending on the cord length. If in doubt, use the next heavier gauge. The smaller the gauge number, the heavier the cord. Only round, jacketed cords listed by Underwriter's Laboratories (UL) should be used.
- When working with the tool outdoors, use an extension cord designed for outside use.

MINIMUM GAUGE EXTENSION CORD RECOMMENDED SIZES FOR USE WITH STATIONARY ELECTRIC MACHINES			
AMPERE RATING	VOLTS	TOTAL LENGTH OF CORD IN FEET	GAUGE OF EXTENSION CORD
0-6	120	Up to 25	18 AWG
0-6	120	25-50	16 AWG
0-6	120	50-100	16 AWG
0-6	120	100-150	14 AWG
6-10	120	Up to 25	18 AWG
6-10	120	25-50	16 AWG
6-10	120	50-100	14 AWG
6-10	120	100-150	12 AWG
10-12	120	Up to 25	16 AWG
10-12	120	25-50	16 AWG
10-12	120	50-100	14 AWG
10-12	120	100-150	12 AWG
12-16	120	Up to 25	14 AWG
12-16	120	25-50	12 AWG
12-16	120	GREATER THAN 50 FEET NOT RECOMMENDED	



# UNPACKING

## ⚠ WARNING:

- The machine is heavy, two people are required to unpack and lift.
- Prior to tool assembly and use, read this manual thoroughly to familiarize yourself with proper assembly, maintenance and safety procedures.

Check shipping carton for damage before unpacking. Carefully remove components in top foam layer. Remove the top layer of foam then remove all components in the bottom layer of foam. Lay out all parts on a piece of cardboard or other clean, flat surface. Two or more people are needed to lift the saw out of the carton. Always check for and remove protective shipping

materials around motors and moving parts. Do not discard shipping carton and packing materials until you have carefully inspected the contents, assembled the machine and are satisfied that it operates correctly.

Compare package contents to Component Parts List and Hardware Package List prior to assembly to make sure all items are present. Carefully inspect parts to make sure no damage occurred during shipping. If any parts are missing, damaged or preassembled, do not assemble. Instead call DELTA® Customer Care at 1-800-223-7278 for assistance.

After assembly remove any protective materials and coatings from all the parts and the table saw.

## PACKAGE CONTENTS DESCRIPTION (QTY)

- A. Saw
- B. Stand Handle
- C. Wheels
- D. Pedal Assembly
- E. Right Support Rod
- F. Left Support Rod
- G. Support Rod Connection Tube

- H. Cross Connect Assembly
- I1. Upper Stand Assembly Part 1
- I2. Upper Stand Assembly Part 2
- J. T-Square Fence
- K. 10 in. Carbide Tipped Blade
- L. Miter Gauge
- M. Blade Guard Assembly

- N. Anti-Kickback Pawls
- O. Throat Plate

The following items can be found in their respective storage areas located on the saw:

- a. Blade wrenches (2)
- b. Push Stick

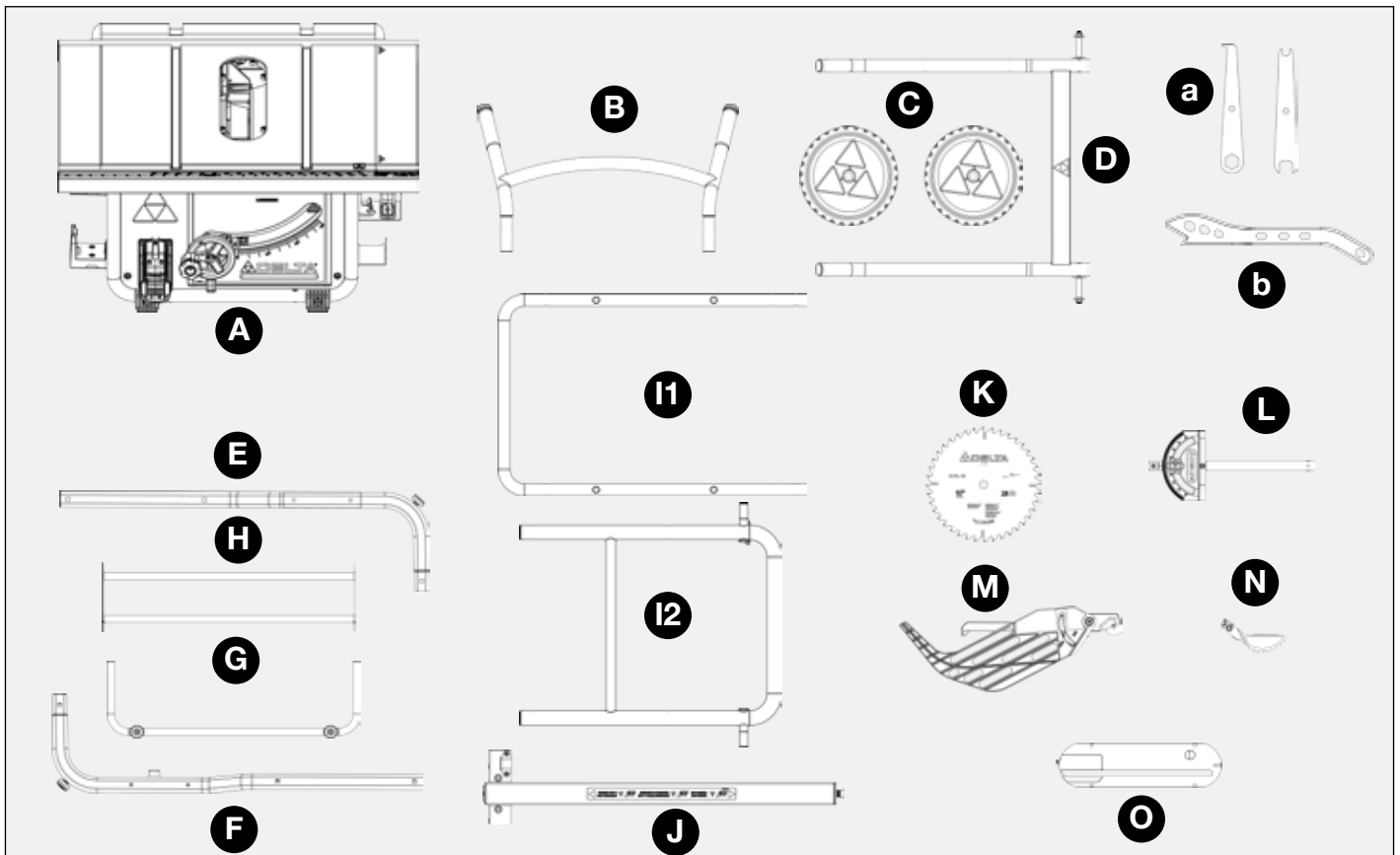

# UNPACKING

## CONTENTS OF HARDWARE BAGS

- aa. M6 x 30 Hex Bolt (4)
- bb. M8 x 67 Carriage Screw (4)
- cc. Plastic Spacer (8)
- dd. M8 Locknut (12)
- ee. M8 x 75 Carriage Screw (4)
- ff. M8 x 35 Carriage Screw (2)
- gg. M8 x 30 Carriage Screw (2)
- hh. 5mm Allen Wrench (1)
- ii. M6 x 20 Button Head Hex Socket Screw (2)
- jj. Wheel Handle Shoulder Screw (1)
- kk. Height Adjustment Wheel Knob
- ll. M8 x 55 Button Head Socket Screw (4)
- mm. Fence Handle

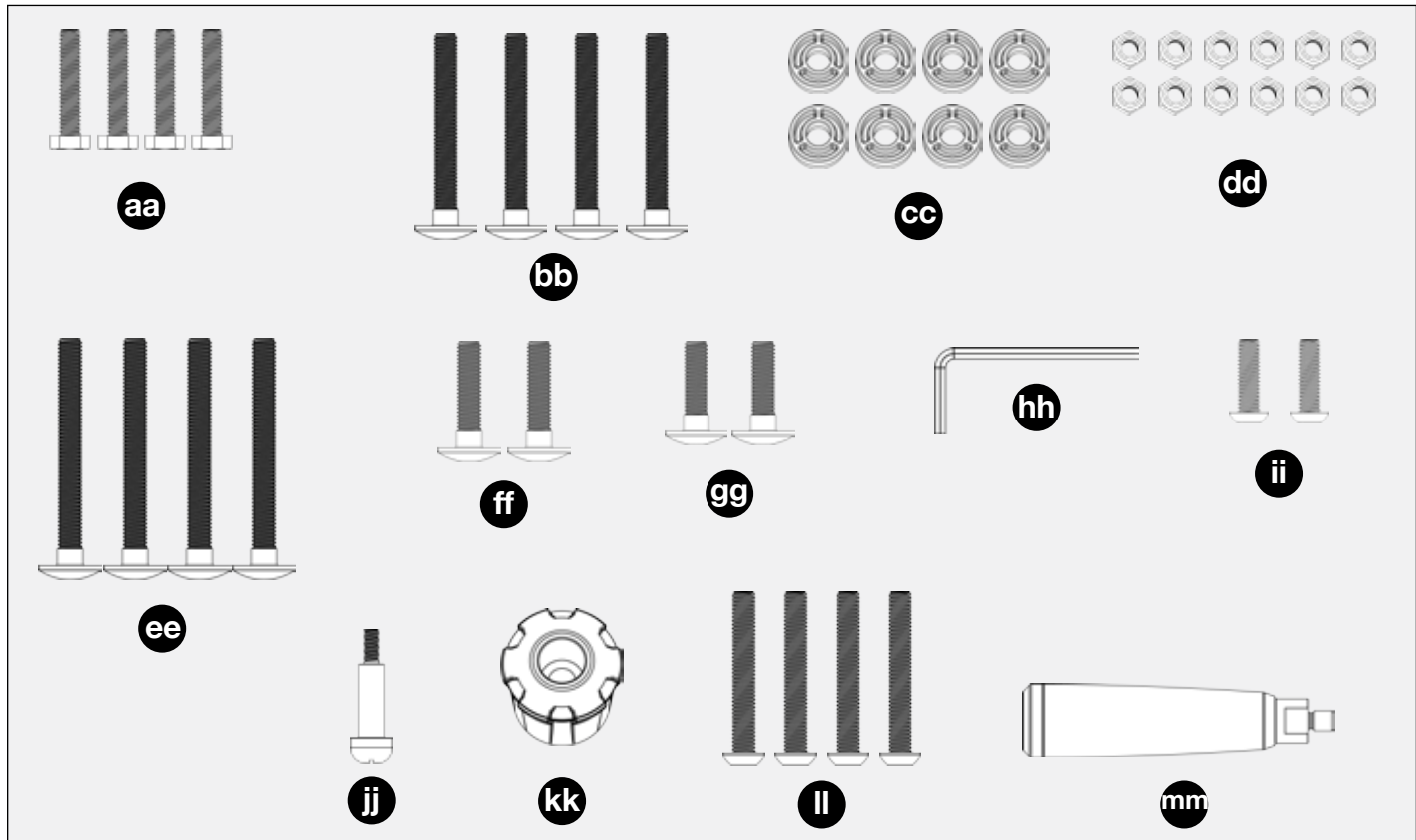

To measure fastener length, refer to page 7 of Parts List.

# ASSEMBLY

### ⚠ CAUTION:

- Do not lift saw without help. Hold it close to your body while lifting. Keep knees bent and lift with you legs, not your back.
- Fully assemble saw with stand prior to use.
- Stand assembly is an integral and necessary part of the support structure for this saw.
- Do not modify saw, or create accessories not

recommended for use with this saw.

- Make sure power switch is in “OFF” position before connecting to power supply. Do not connect to power supply until assembly is complete.

### ⚠ CAUTION:

- Avoid contact with blade teeth. Keep blade stored or lowered when possible.

# ASSEMBLY

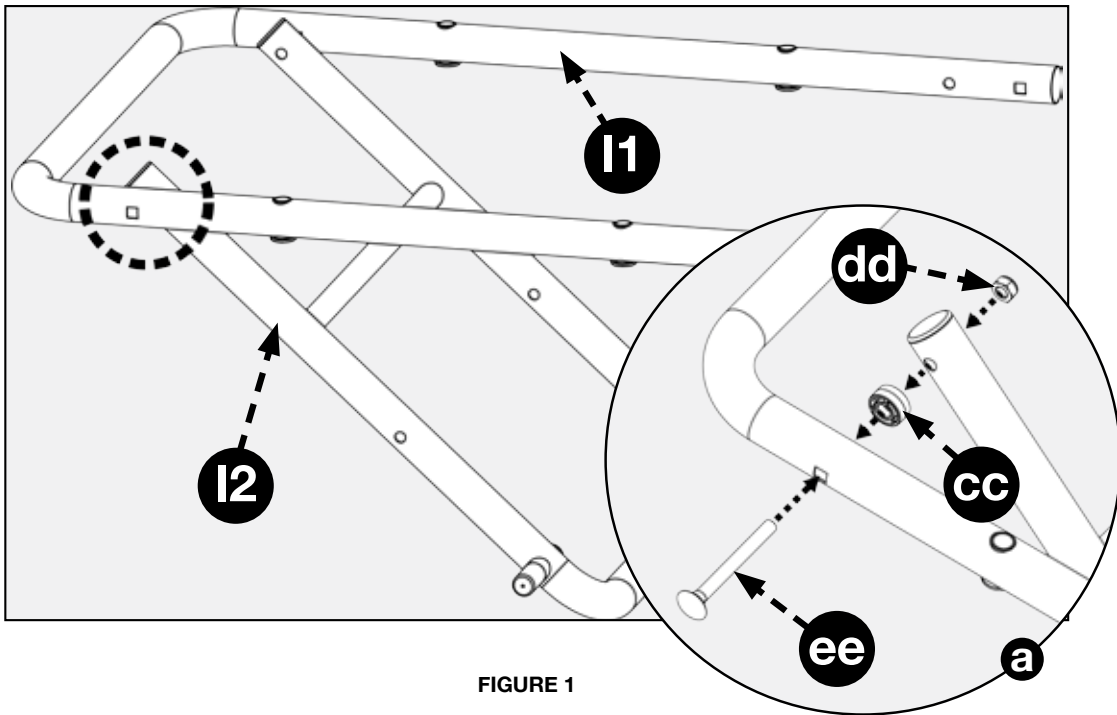

FIGURE 1

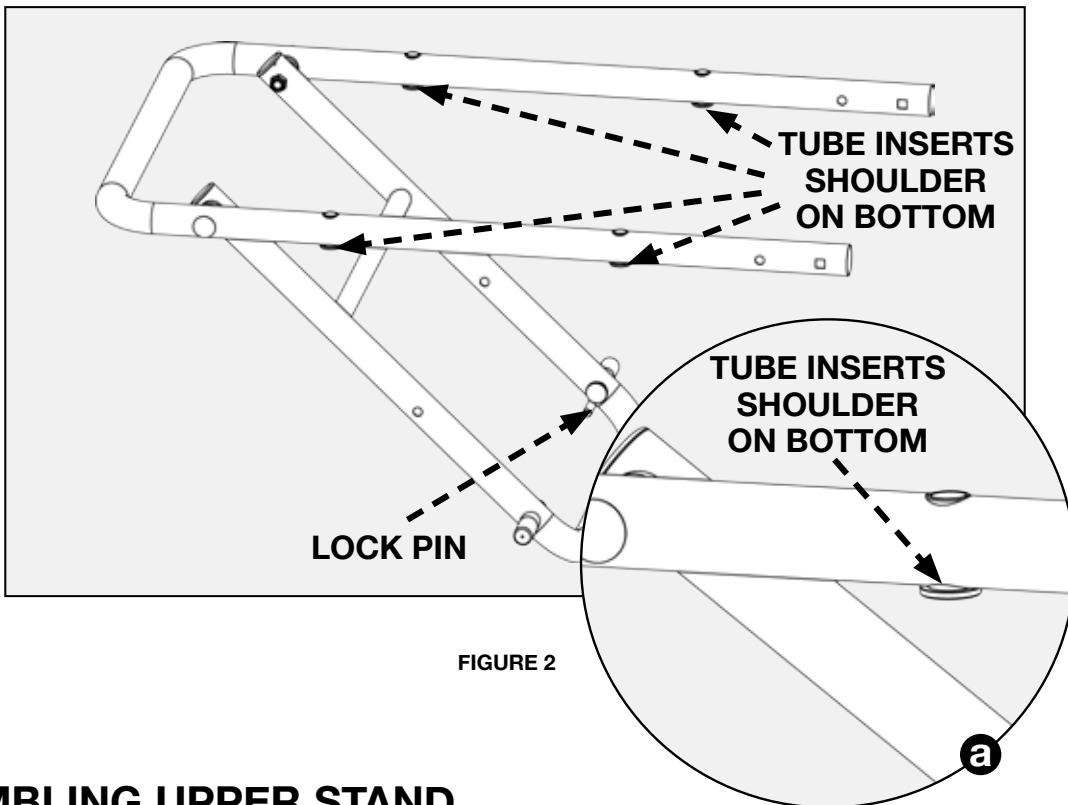

FIGURE 2

## ASSEMBLING UPPER STAND

Assemble upper half (I1) of upper stand assembly to lower half (I2) of upper stand assembly as shown in Figure 1 using M8 x 75mm carriage screw (ee), spacer (cc) and M8 locknut (dd) to each side of upper stand assembly.

**NOTE:** I1 is attached to saw table assembly and secured with cable ties. Remove cable ties prior to assembling I1 and I2.

**NOTE:** Orientation of I2 lock pin is on the right side of the assembly and orientation of I1 will have shoulder of tube inserts on bottom as shown in Figure 2.

Finished upper stand assembly will appear as shown in Figure 2.

**IMPORTANT:** Tube insert shoulder on bottom.

# ASSEMBLY

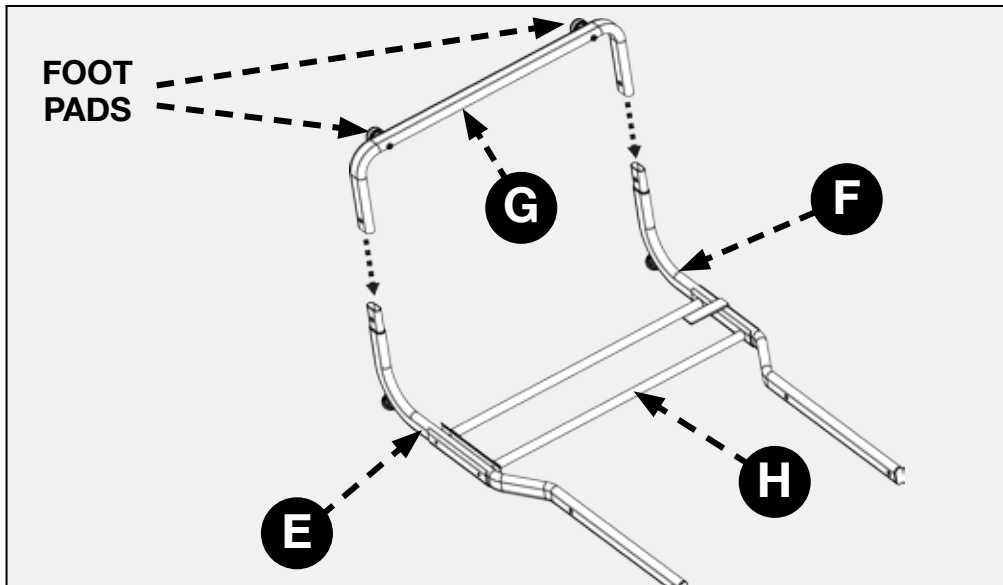

FIGURE 3

## ASSEMBLING THE STAND

Layout the left and right support rod assemblies (E & F).

Place the cross connect assembly (H) between the support rod assemblies and connect the support rod connection tube (G) to the ends of the support rod assembly tubes as shown in Figure 3.

**NOTE:** Ensure foot pads are oriented as shown in Figure 3.

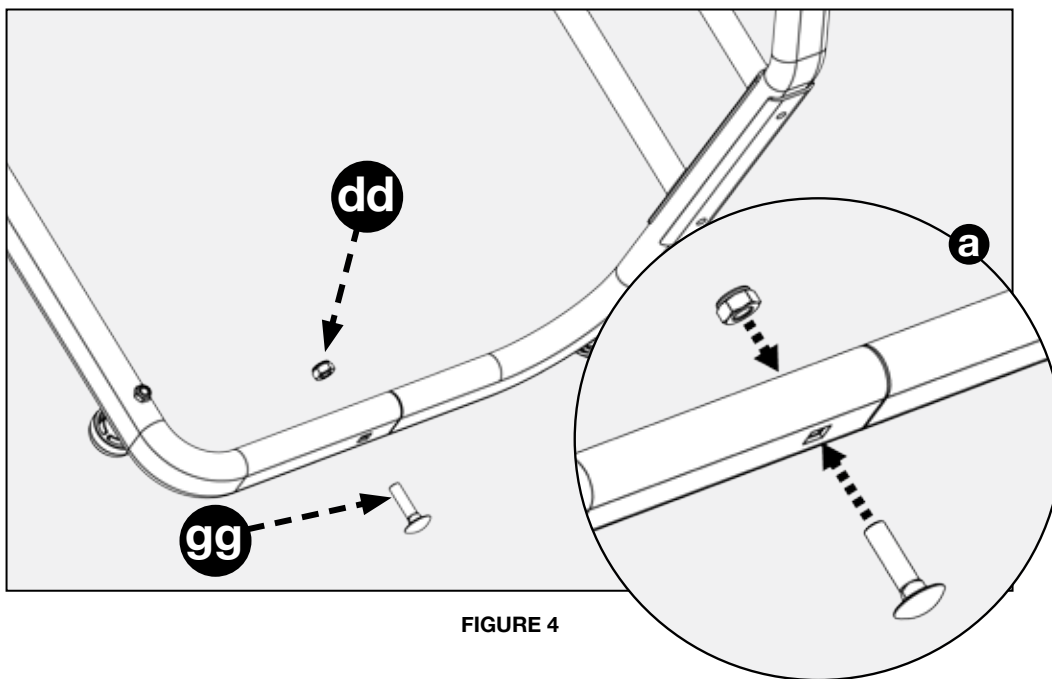

FIGURE 4

Secure the support rod assemblies to the support rod connect tube using two M8 x 30 Carriage bolts (gg) and M8 lock nuts. (dd)

See Figure 4 & 4a.

# ASSEMBLY

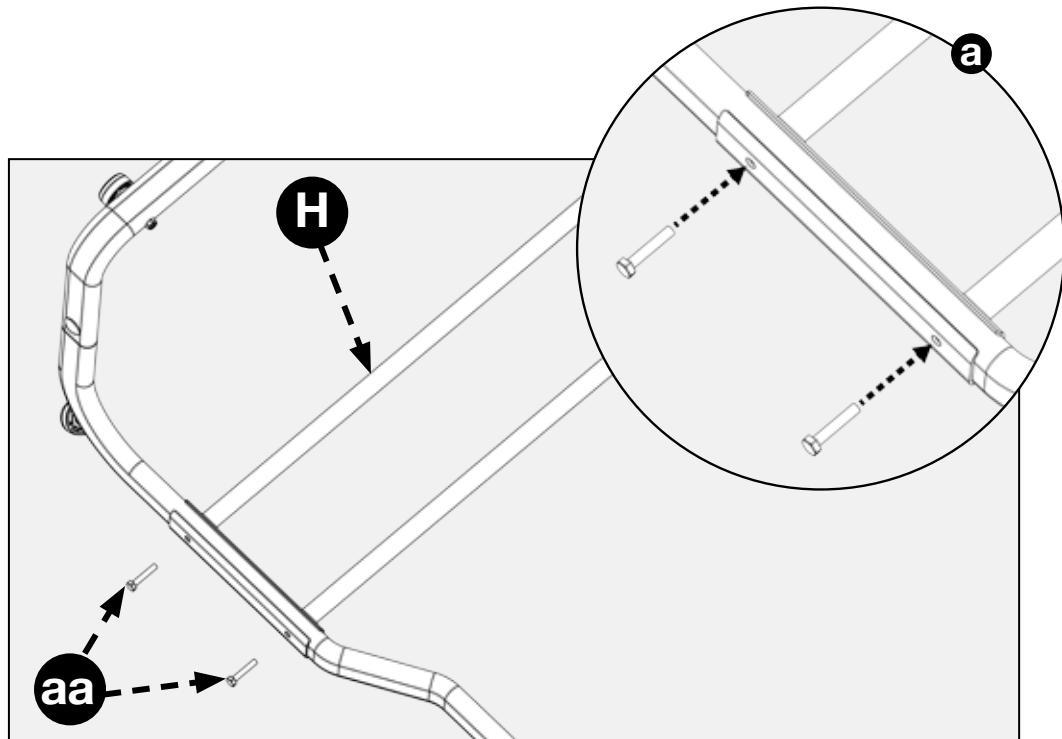

FIGURE 5

Secure the cross connect assembly (H) to the support rod assembly tubes using four M6 x 30 hex bolts. (aa)  
See Figure 5 & 5a.

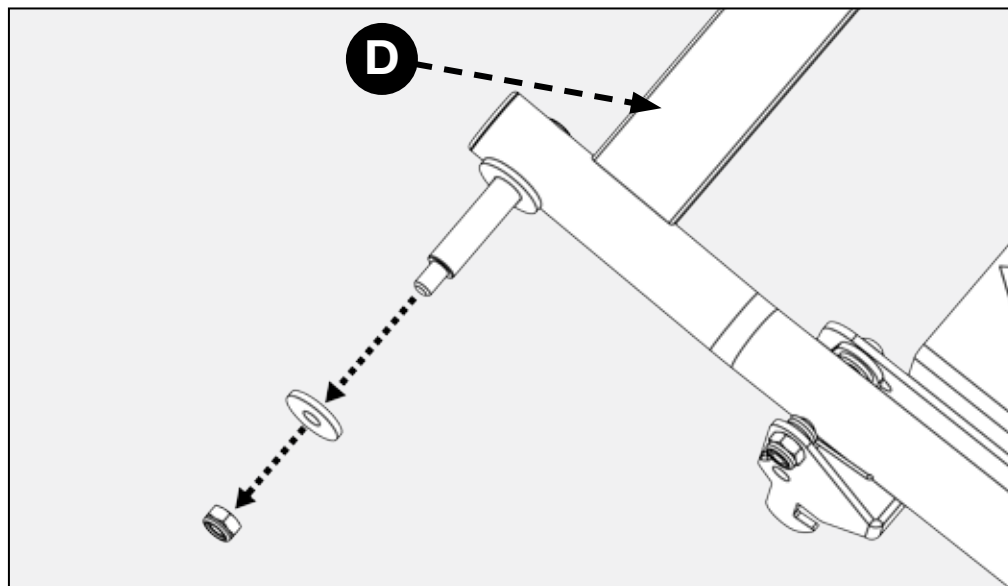

FIGURE 6

## WHEELS

Remove the lock nut and washer from each axle on the pedal assembly (D) as shown in Figure 6.

# ASSEMBLY

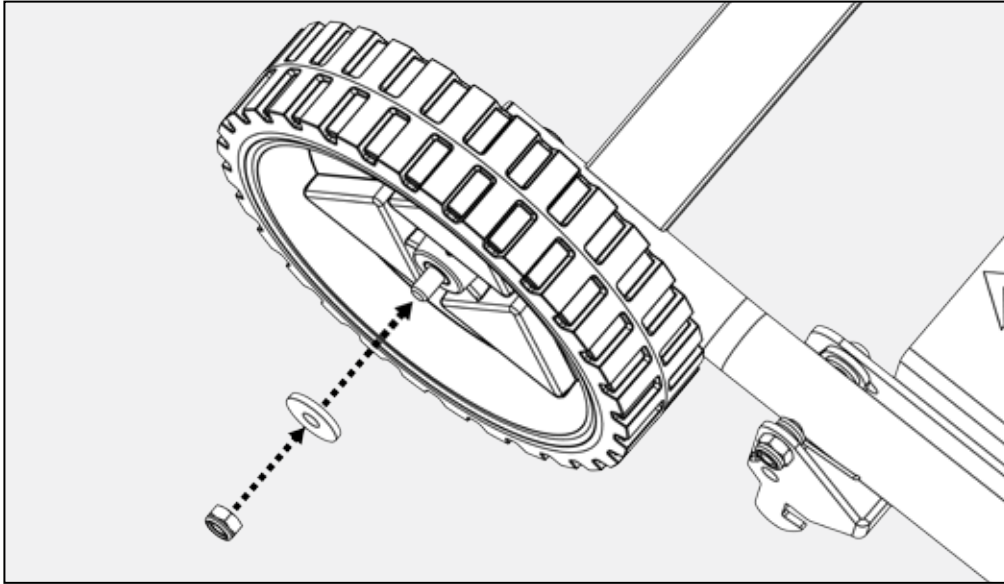

FIGURE 7

Slide the wheels over axles and secure using the two washers and M8 lock nuts.  
See Figure 7.

## PEDAL ASSEMBLY

Attach the pedal assembly (D) to the upper stand assembly using two M8 x 75 Carriage screws (ee), spacers (cc) and M8 lock nuts (dd). See Figures 8 & 9 to verify the correct orientation of the pedal assembly (C) to the upper stand assembly.

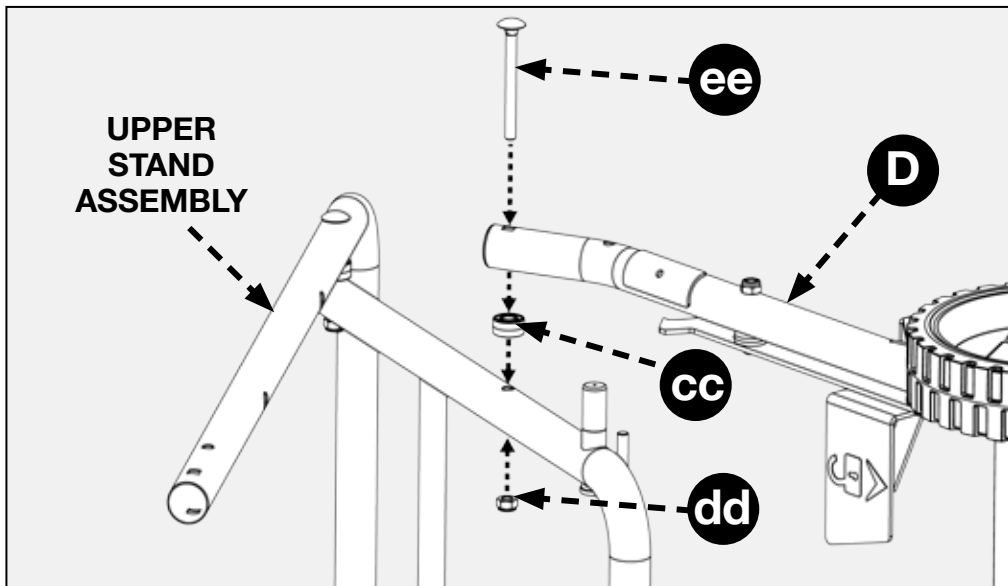

FIGURE 8

# ASSEMBLY

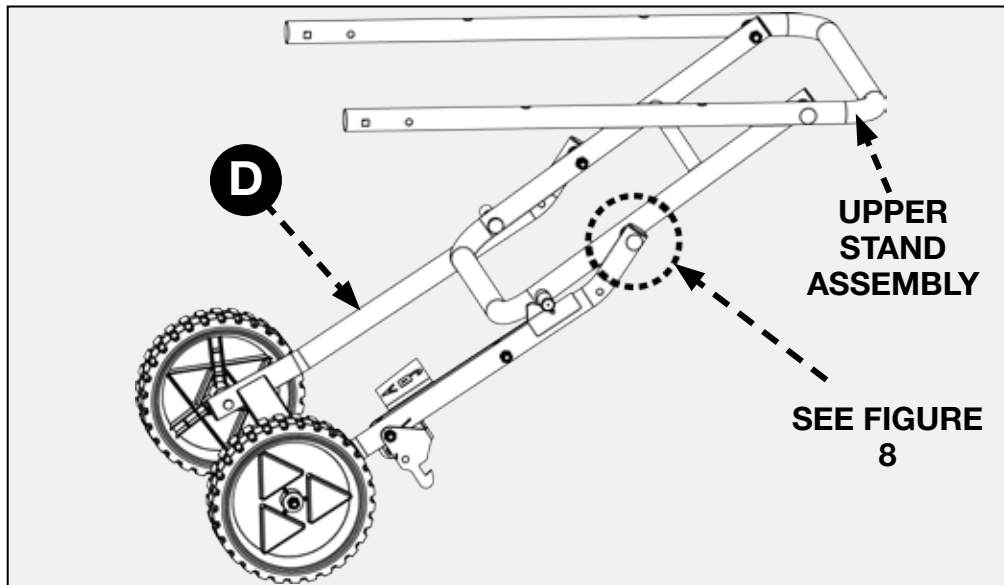

FIGURE 9

Place the sides of the support rod assembly (E & F) so they are outside of the pedal assembly (D) and the feet are pointing down. See Figure 11 for correct position of the feet.

Align the hole in the support rod assembly with the hole in the pedal assembly. See Figure 10.

Secure each side of the support rod assembly using two M8 x 67 carriage bolts (bb), spacers (cc) and M8 lock nuts (dd). See Figures 10 & 11.

**NOTE:** At any time, to aid in assembly, refer to front cover of this manual for completed saw.

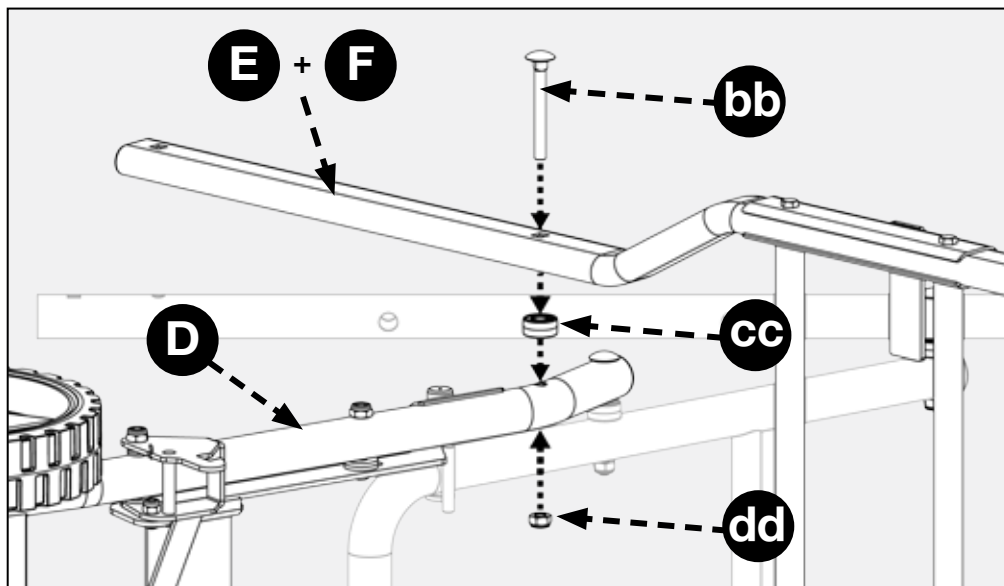

FIGURE 10

# ASSEMBLY

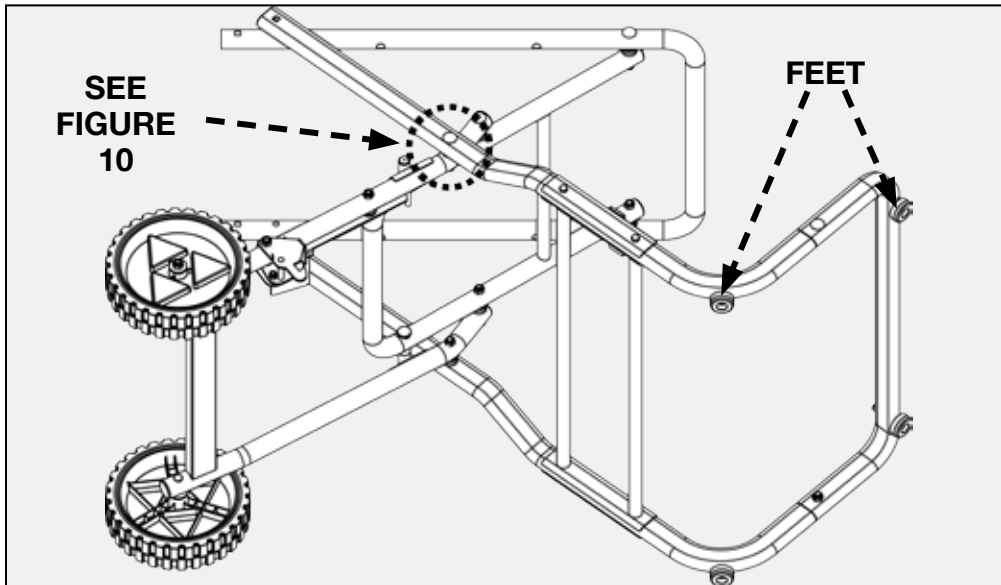

FIGURE 11

## UPPER STAND ASSEMBLY

Insert the stand handle (B) into the upper stand assembly as shown in Figure 12.

Insert M8 x 35 carriage screw (ff) into the square hole at the end of the upper stand assembly (square hole at end of tube see Figure 12a) secure carriage screw (ff) with M8 Locknut (dd). Repeat this step on the other side of the handle.

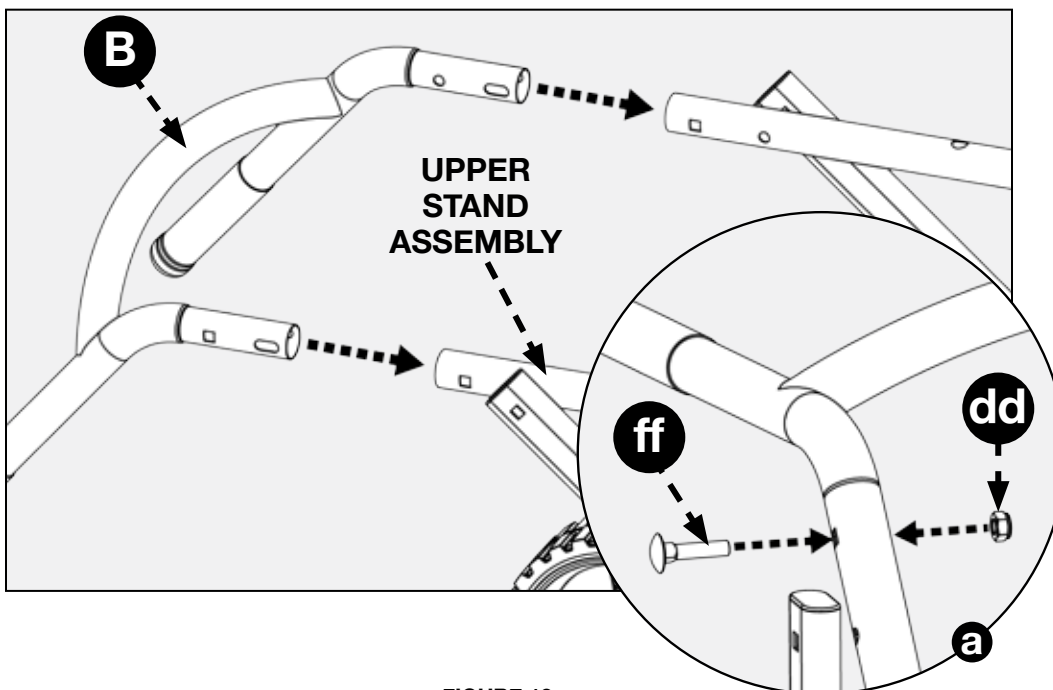

FIGURE 12



# ASSEMBLY

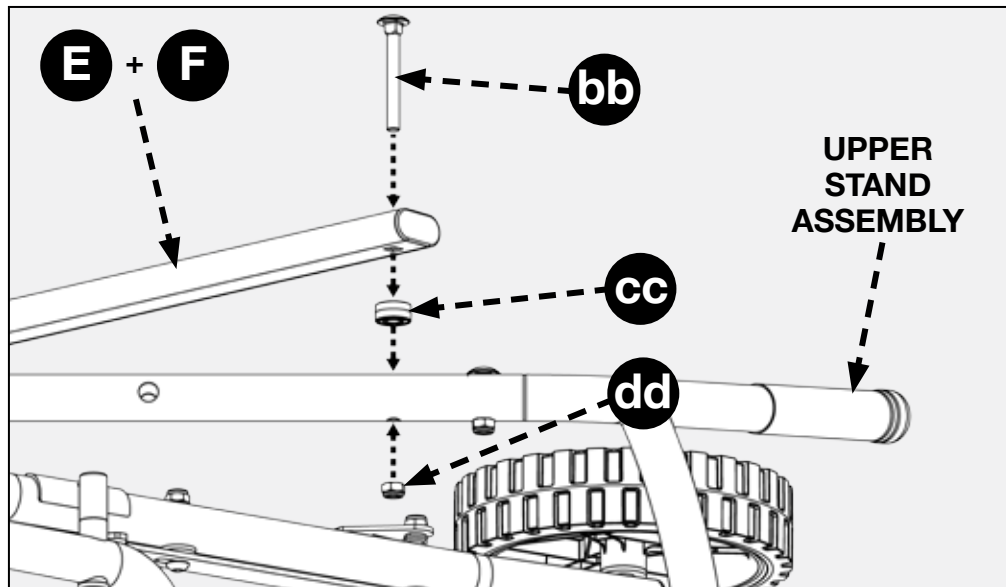

FIGURE 13

Attach the right and left support rod assemblies (E & F) as shown in Figure 13 to the upper stand assembly with two M8 x 67 carriage screws (bb), spacer (cc) and M8 locknuts (dd) as shown in Figures 13 & 14.

**NOTE:** Ensure the spacer (cc) is between the support rod assembly and the upper stand assembly as shown in Figure 13.

**NOTE:** Make sure all hardware is tight but not overtight. The amount of tightening applied to pivoting joints will affect the stand operation.

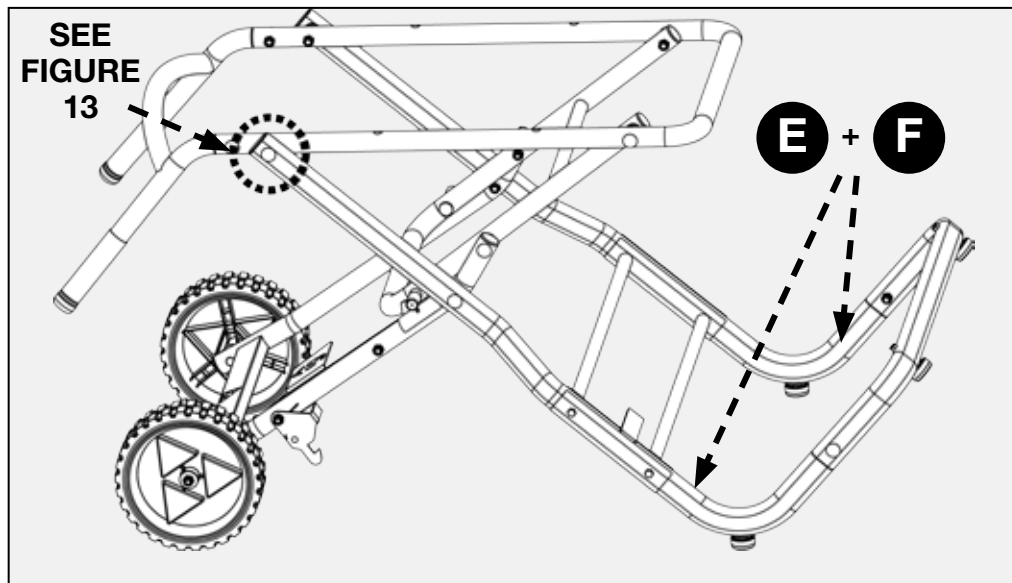

FIGURE 14

Correct stand assembly will appear as shown in Figure 14.

# ASSEMBLY

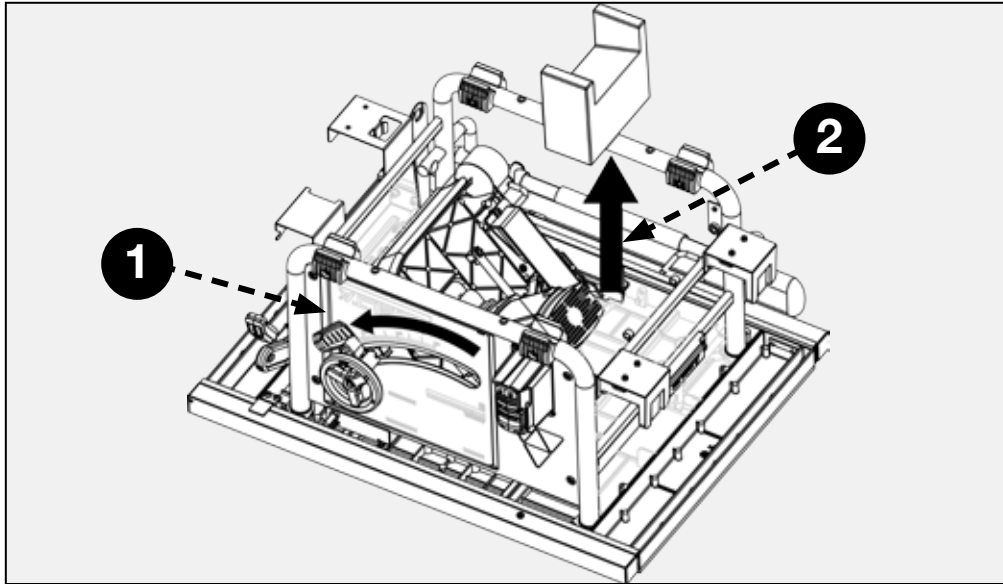

FIGURE 15

## ATTACH SAW TO STAND ASSEMBLY

Unlock the bevel lock tilt and rotate the motor assembly enough to remove the shipping foam protecting the saw motor as shown in Figure 15.

**⚠ WARNING:** Do NOT turn the handwheel during this step.

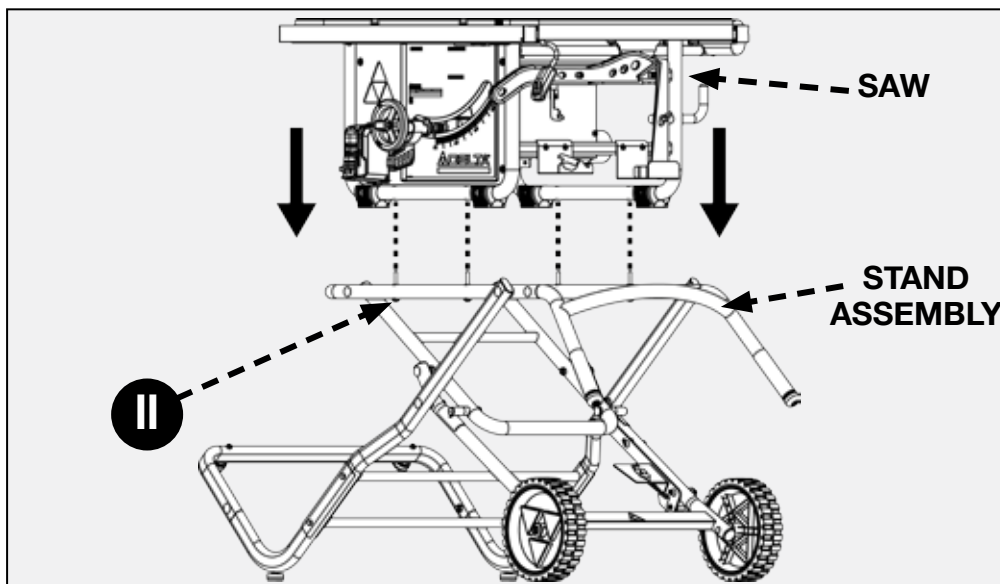

FIGURE 16

Place saw on stand and align threaded holes in saw with through holes on stand secure with four M8 x 55 button head socket screws (II).

See Figure 16.

# ASSEMBLY

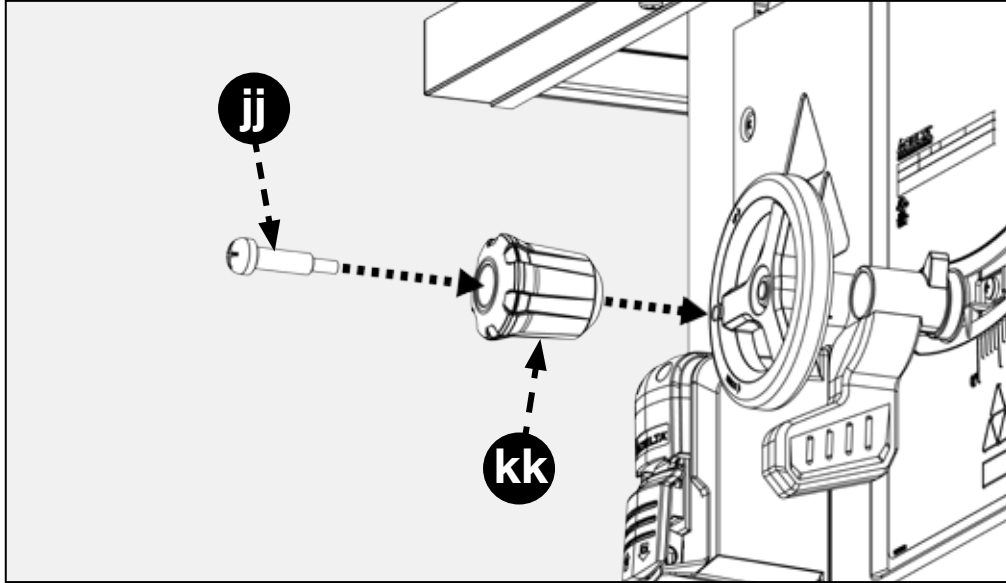

FIGURE 17

## Height Adjustment Knob Installation

1. Insert wheel handle shoulder screw (jj) into height adjustment wheel knob (kk) as shown in Figure. 17.
2. Tighten shoulder screw with Phillips Screw Driver into the Hand Wheel. Height adjustment wheel knob should rotate freely around shoulder screw when raising or lowering the blade with the Height Adjustment Hand Wheel.

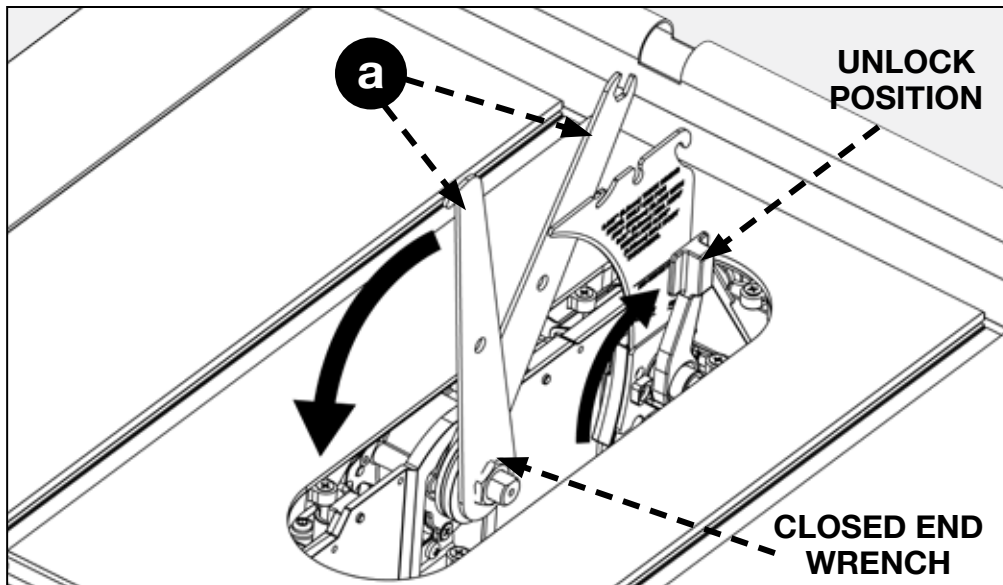

FIGURE 18

## BLADE AND GUARDS

### Attach the Blade

After installing height adjustment knob as shown in Figure. 17, raise motor/arbor assembly to the upper most position to provide easy access to riving knife lock lever and arbor assembly.

Ensure riving knife lock lever is in unlock position. See Figure. 18.

Detach the on-board wrenches located on the right side of the saw by loosening and removing M8 wing nut.

Place the open-ended wrench (a) on the spindle shoulder between the arbor flange and inner flange. Place the closed end wrench (a) over the arbor nut. Holding the spindle shaft in place, loosen and remove the arbor nut and arbor flange.

See Figure 18.

# ASSEMBLY

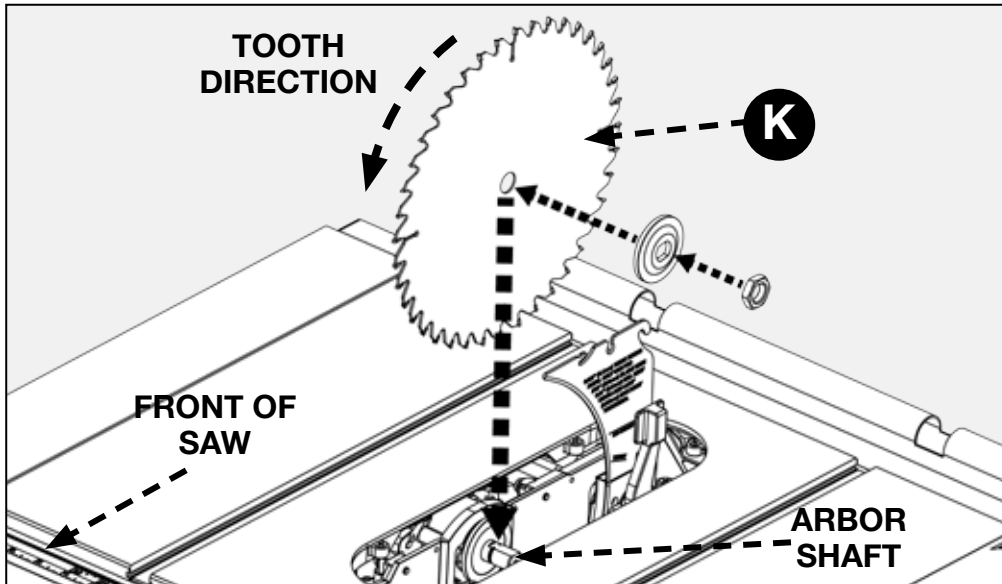

FIGURE 19

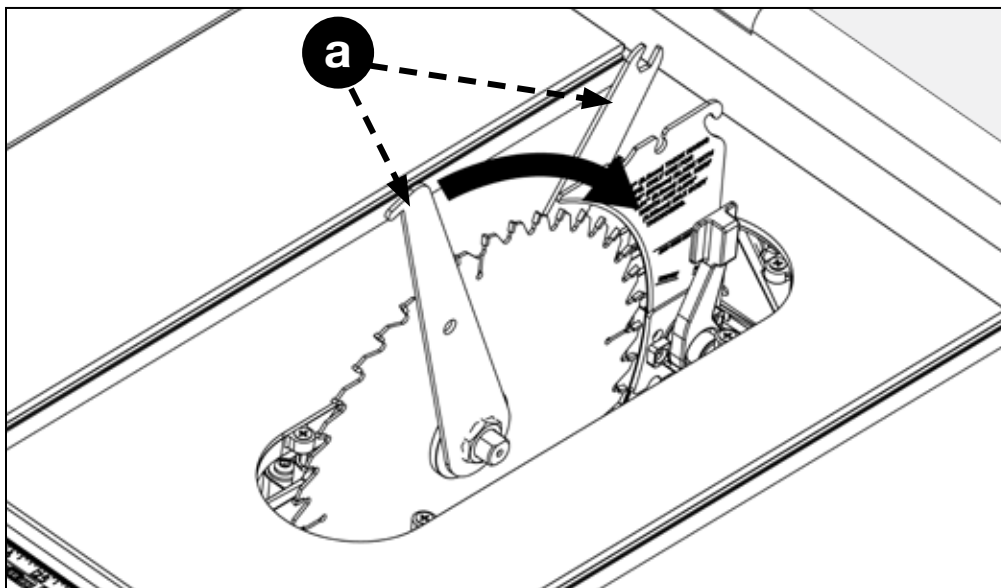

FIGURE 20

Place blade (K) on the arbor shaft with the teeth on the blade pointing toward the front of the saw. Place flanged washer on the shaft with the large side of the washer against the blade, then secure blade assembly with nut. (Figure. 19)

Tighten nut with blade wrenches (a). Open end wrench will fit on the arbor shaft between the inner flange washer and the motor assembly (if necessary, turn arbor shaft to align flats on the arbor shaft to the wrench). Closed end wrench will fit on the nut. See Figure 20.

Return wrenches (a) to onboard storage location. Position the riving knife in the “Thru-cut” position prior to installation of that plate.

Details for positioning the riving knife are on page 32 RIVING KNIFE POSITION AND ALIGNMENT Section.

See Figure 21.

# ASSEMBLY

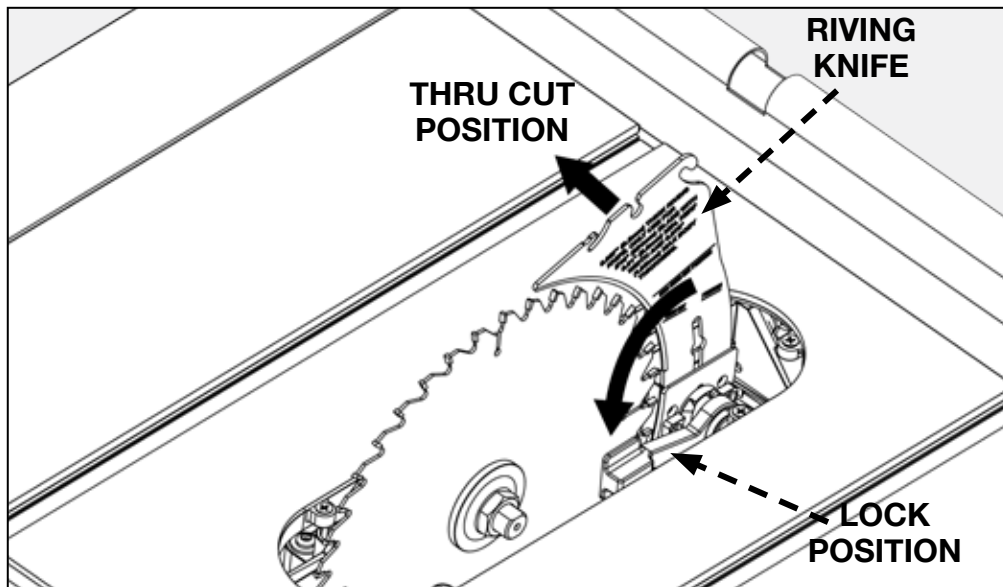

FIGURE 21

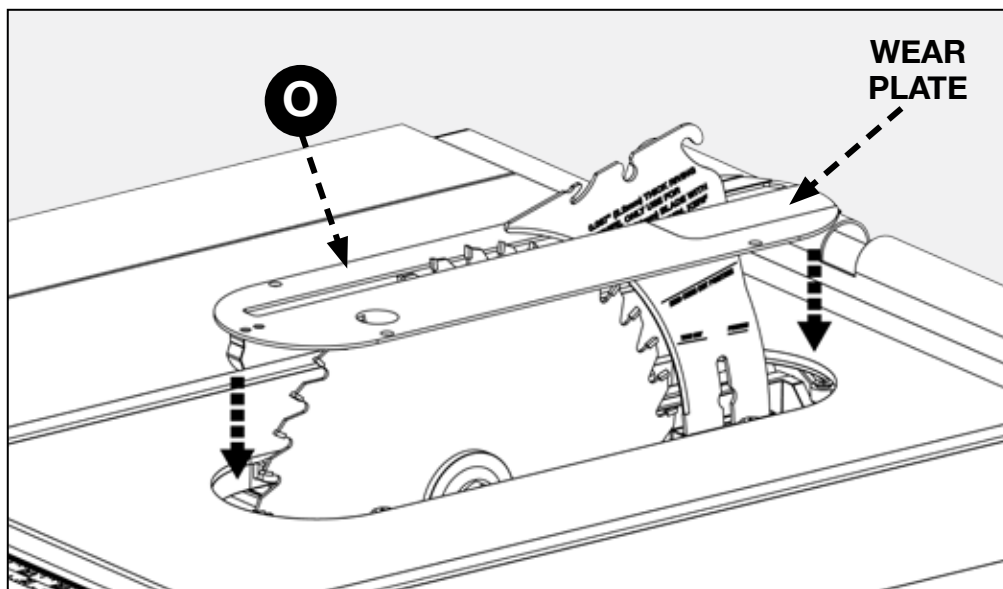

FIGURE 22

**⚠ WARNING:** To reduce the risk of serious injury,

- the riving knife must be installed for every through cut and for every non-through cut unless the riving knife would interfere with the cut.
- always use a blade with the correct thickness to match the riving knife. (0.10" (2.6mm) min. kerf width and 0.073" (1.85mm) max body thickness)
- The riving knife must be securely positioned in the "up" or "through cut" position when using the antikickback pawls and blade guard.
- Make sure the riving knife is properly aligned to the blade. (See Riving Knife Position and Alignment, Page 33.

## Insert Throat Plate

Refer to Figure 22.

Place the throat plate (O) in place with the wear plate on the rear.

Engage the rear tab on the throat plate under the table and press the front end down until the front tab snaps into place on the table.

# ASSEMBLY

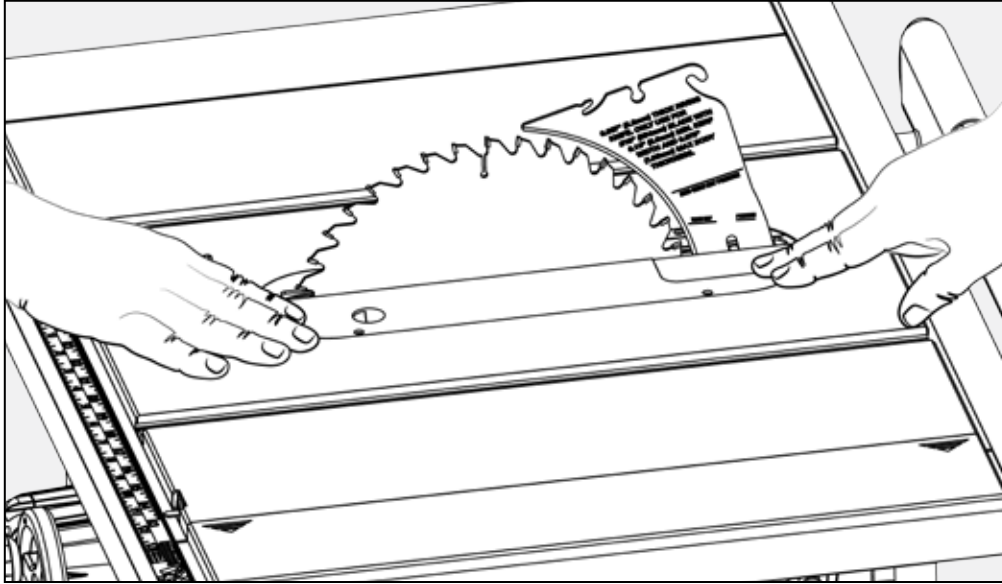

FIGURE 23

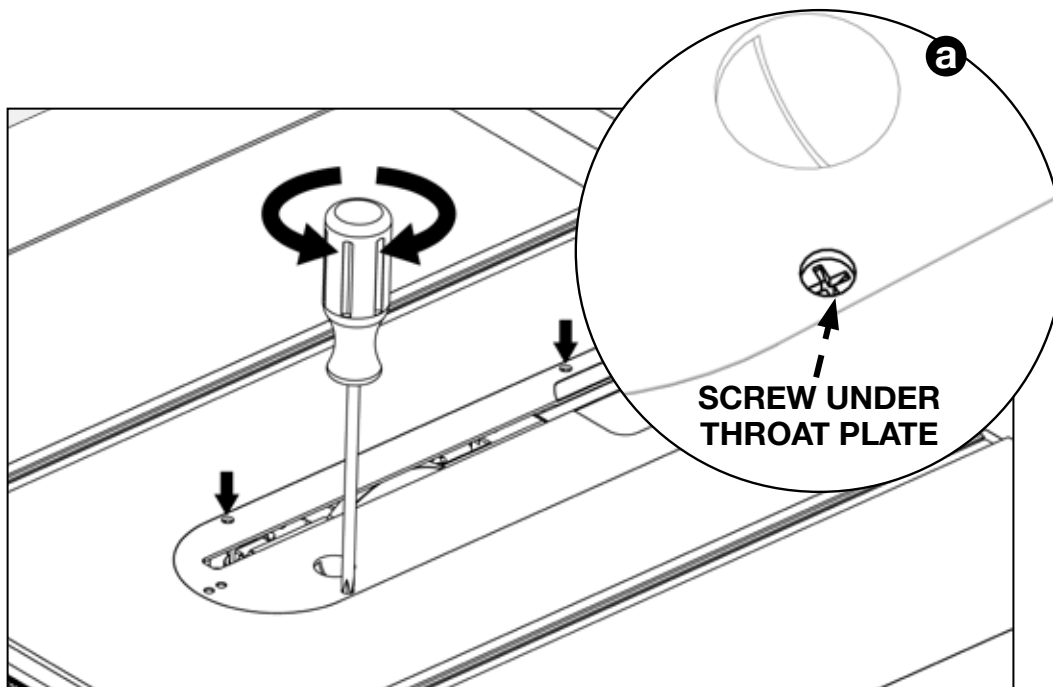

FIGURE 24

Level the throat plate to the table top using (4) flat head screws. See Figure 23 and 24. For more details about leveling throat plate, see page 29.

**NOTE:** There is a fifth flat head screw under the throat plate that is adjusted to provide support under the wear plate. Adjust this screw as needed to provide support.

**⚠ WARNING:** To reduce risk of serious injury, do not attempt to secure the throat plate to the table using the throat plate leveling screws.



# ASSEMBLY

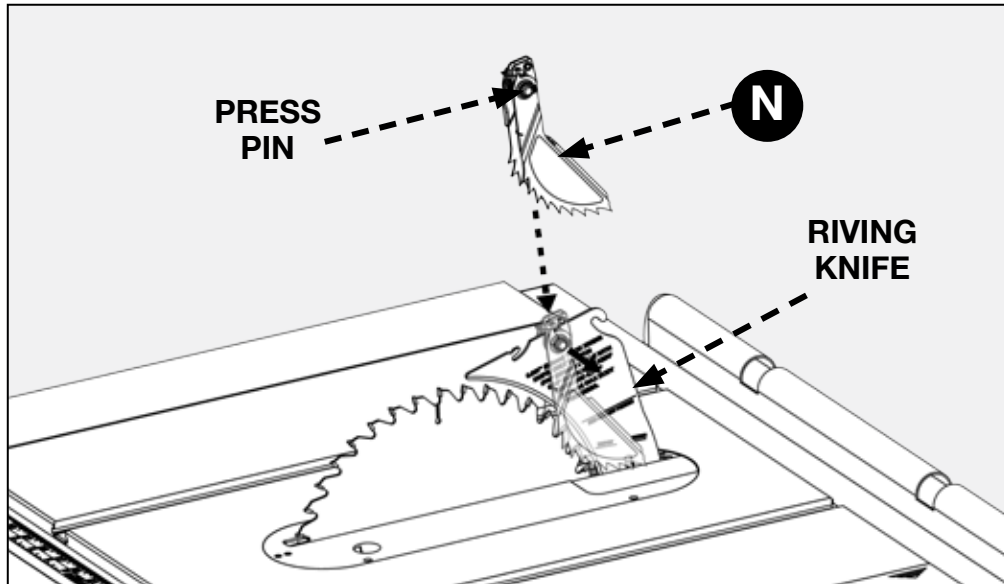

FIGURE 25

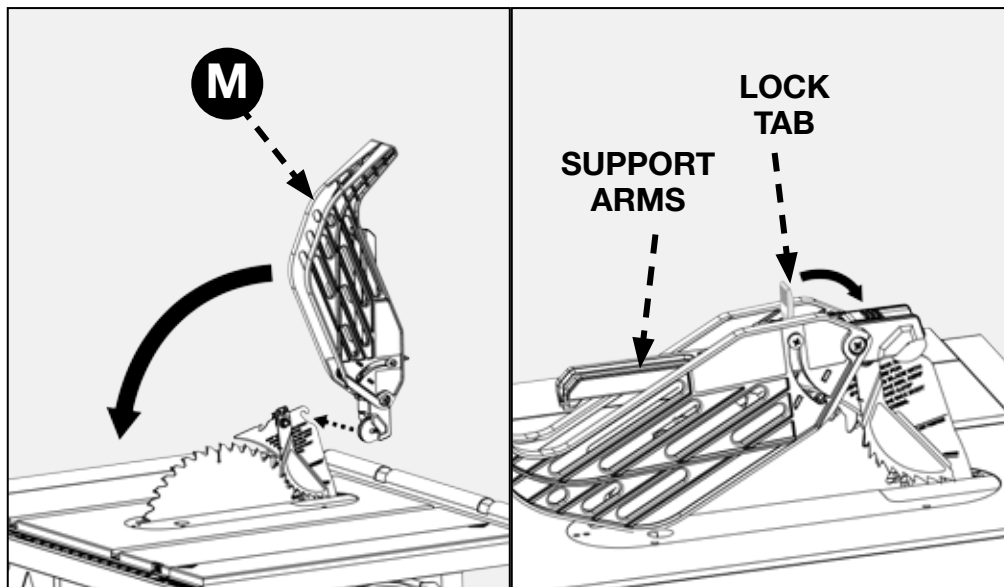

FIGURE 26

FIGURE 27

## Anti-Kickback Pawls and Blade Guard

Press spring loaded pin on the right side of the anti-kickback pawl assembly (N) insert over the middle slot on the riving knife.

Once inserted, release the spring-loaded pin so that it pops back into place. Ensure it is locked in place by gently pulling up on the anti-kickback pawl assembly (N).

Hold the blade guard assembly (M) as shown in Figure 26 and engage the pin with the slot in the riving knife. Pull blade guard assembly up into place.

Rotate the blade guard so that the support arms are parallel to the table. Then lock the blade guard in place by depressing the lock tab.

Verify the Blade Guard Assembly is properly locked in place. Do this by gently lifting up on the support arms after the lock tab has been depressed. If blade guard is not properly locked onto the riving knife, support arms will raise up and lock tab will spring up to the unlocked position.

See Figure 27.

**⚠ WARNING:** To reduce risk of serious injury. It is important that you do not use the table saw if blade guard assembly is not locked into place on the riving knife.

# ASSEMBLY

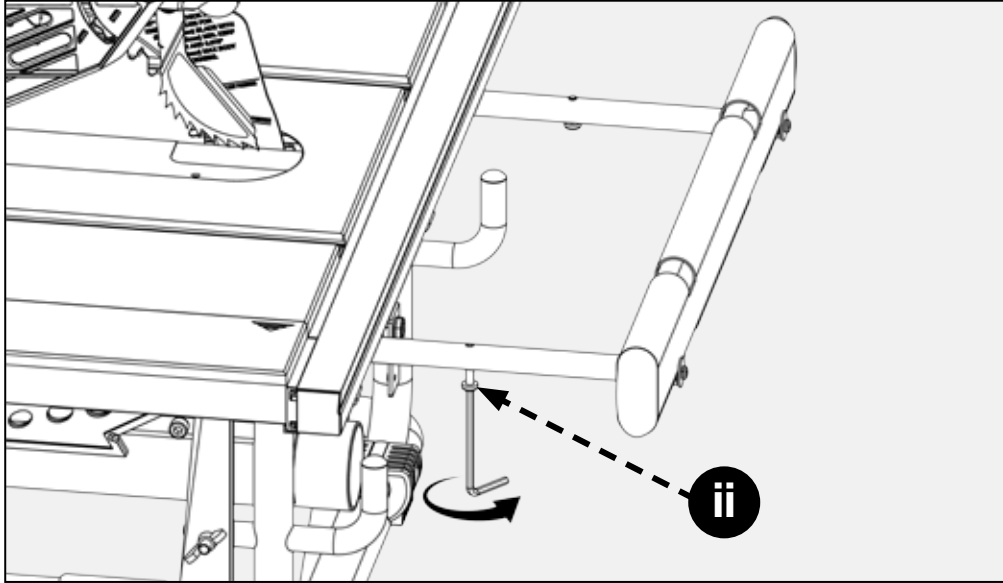

FIGURE 28

## Outfeed Support Stops

Refer to Figure 28.

Extend the rear table support to expose the two holes. Insert an M6 x 20 button head hex socket screw (ii) from underneath, tighten with the supplied allen wrench.

Repeat on other side of outfeed support.

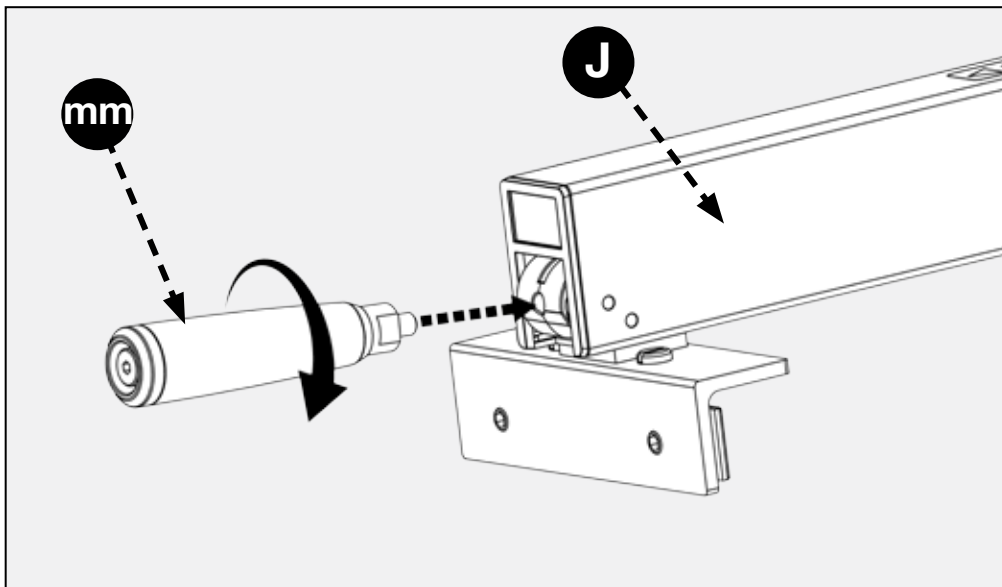

FIGURE 29

Assemble handle (mm) to fence assembly (J) as shown in Figure 29.



# ASSEMBLY

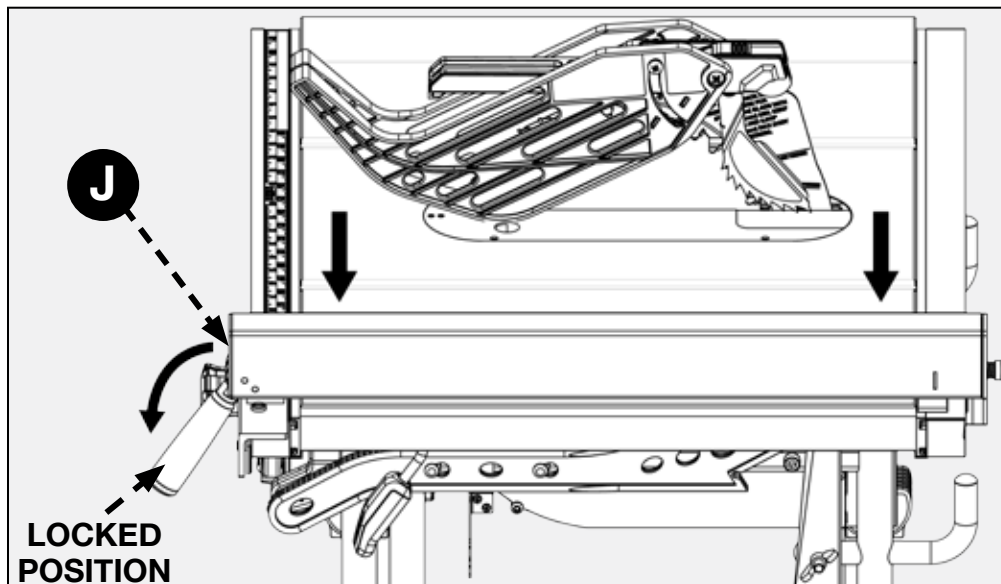

FIGURE 30

Position the T-square fence (J) over the front and rear rails. Ensure the fence lock is in the unlocked (up) position. Lower T-square fence (J) on to both front and rear rails. Position T-square fence (J) on the table as desired and lock into place.

See Figure 30.

# ASSEMBLY

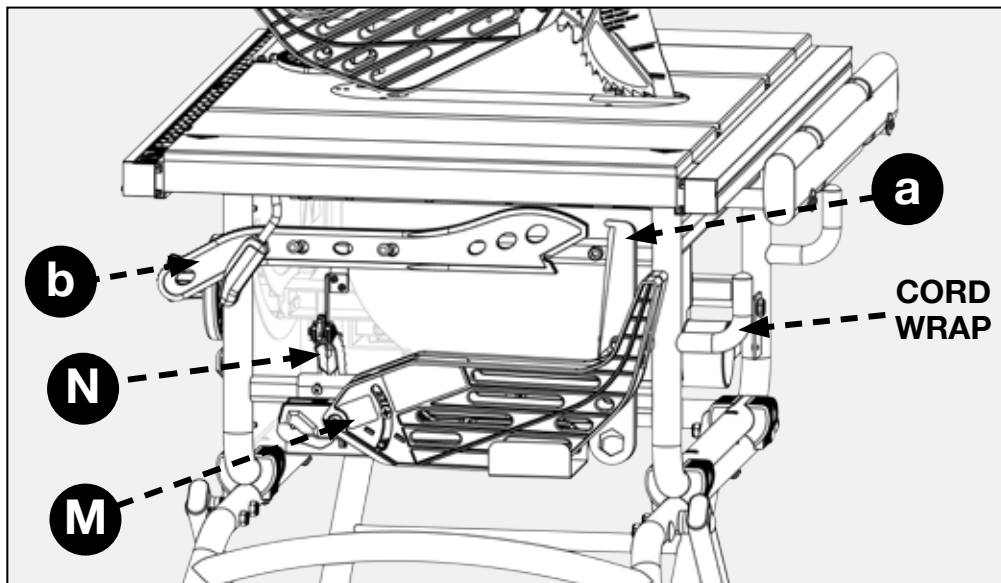

FIGURE 31

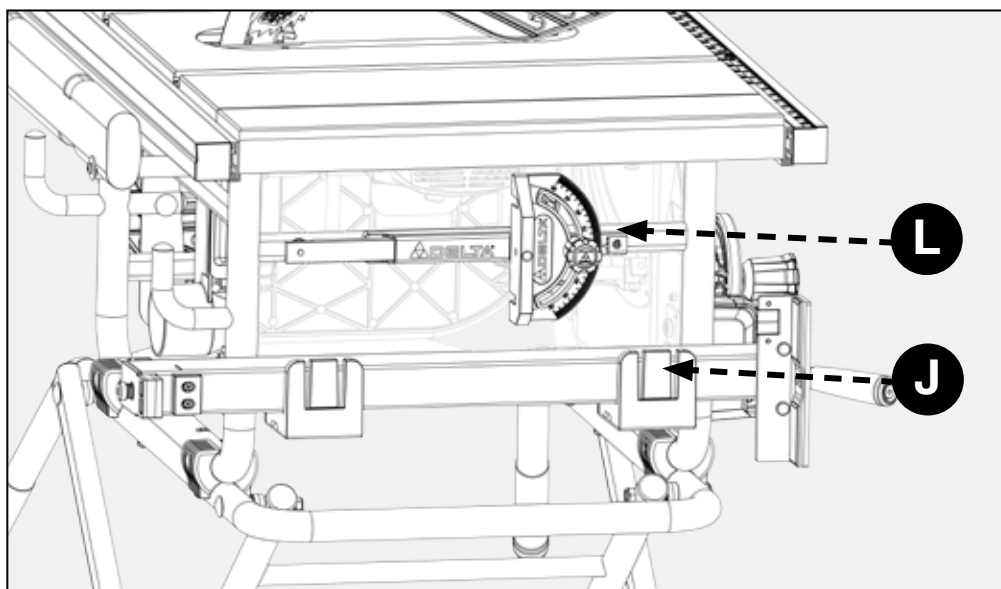

FIGURE 32

**NOTE:** Prior to placing the rip fence in the storage position you must temporarily remove the miter gauge from the storage position.

## ON-BOARD STORAGE

Storage is located on the left panel, right panel and back side of the tool as shown in Figures 31 & 32.

b. Push Stick

N. Anti-kickback assembly

a. Wrenches

M. Blade guard assembly

J. Fence

L. Miter gauge

Electrical Cord wrap

# OPERATION

**⚠ WARNING:** Failure to follow these rules may result in serious personal injury.

**READ ENTIRE MANUAL.** In addition to reading these operating instructions, it is important to read and understand the entire manual before operating this saw. Follow all applicable instructions regarding assembly, preparation, and adjustment prior to making any cuts and comply with all safety rules and warnings in this section and elsewhere throughout this manual.

**1. Each time you use the saw, run through the following checklist:**

- Are the power source and power connections adequate for the saw?
- Are the saw and work area free of clutter and by-standers?
- Is the blade tight and properly aligned?
- Does the riving knife thickness match the blade?
- Are the blade and riving knife properly aligned?
- Is the operator qualified to make the cut and familiar with all of the relevant safety rules, warnings and instructions included in this manual?
- Is the operator and everyone in proximity to the saw wearing appropriate eye, hearing and respiratory equipment?
- Are the bevel angle and height adjustment knobs locked in the proper position?
- Is the blade set at the proper height?
- If ripping, is the rip fence parallel to the blade and securely locked in place?
- If crosscutting, is the miter gauge knob too tight?
- If making through cuts with a standard blade, are the blade guard riving knife and anti-kickback pawls properly attached and properly functioning with both guards contacting the table surface?
- Is there proper clearance and support for the workpiece as it leaves the blade?
- Are any cutting aids needed? If so, are they in place, or within reach for proper use?

**2. The use of attachments and accessories not**

**recommended by DELTA® Power Equipment Corporation may result in injury.**

- 3. Replace or sharpen the anti-kickback fingers when the points become dull.**
- 4. Make sure saw is stable and cutting can be accomplished without tipping the saw.**
- 5. Never use the fence and miter gauge together without using a cutoff block as previously described.**
- 6. The proper throat plate must be in place at all times.**
- 7. If your saw makes an unfamiliar noise or if it vibrates excessively, cease operating immediately until the source has been located and the problem corrected.**
- 8. Never perform freehand cutting, plunge cutting, re-sawing or cove-cutting.**

## **AVOID KICKBACK**

A kickback can occur when the workpiece pinches the blade, or binds between the saw blade and the rip fence or other fixed object. This can cause the workpiece to rise from the table and/or be thrown back toward the operator. See instructions for reducing the risk of kickback in page 7 of this manual.

**IF KICKBACK OCCURS,** turn the saw “OFF” and verify proper alignment of the blade, riving knife and miter gauge or rip fence, and the proper functioning of the riving knife, anti-kickback assembly and blade guard before resuming work.

# OPERATION

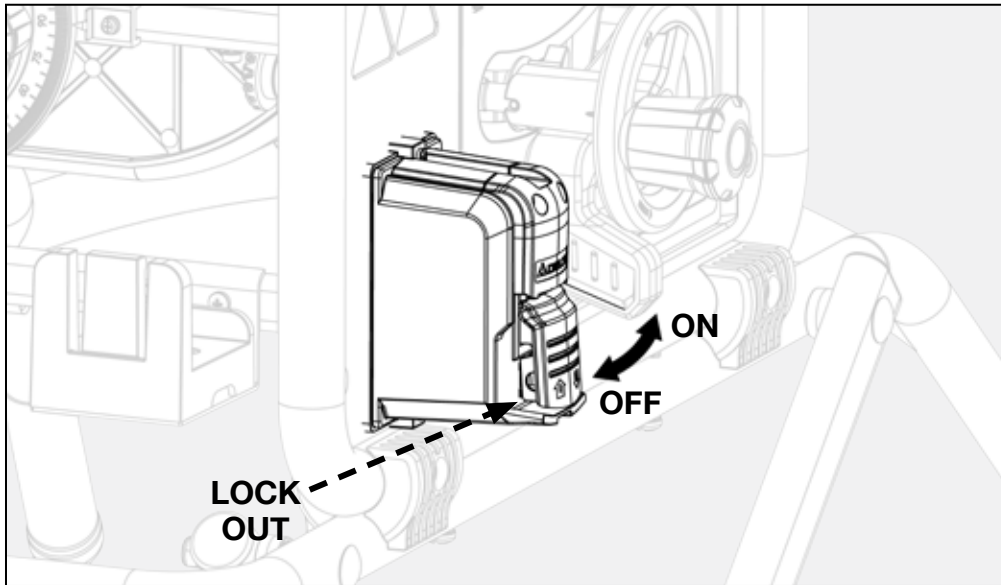

FIGURE 33

## TURNING THE SAW ON AND OFF

The ON/OFF paddle switch is located on the left side of the front panel of the saw.

To turn the saw ON lift the switch. Press the switch down to turn the saw OFF.

When not in use, the saw should be turned off and the power switch locked out to prevent unauthorized use. To lock out power switch, use a standard long shackle lock, with a shackle posts no larger than 9/32-inch (7mm) thick.

See Figure 33.

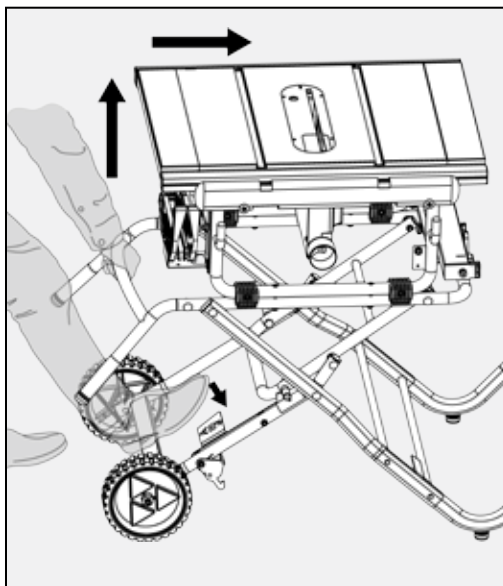

FIGURE 34

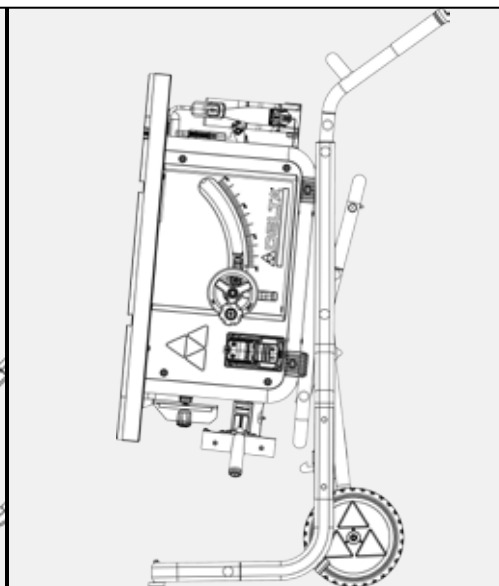

FIGURE 35

## TRANSPORTING THE SAW

To fold stand for moving, return side and rear extension tables to inner position lock side extension into place. Stow rip fence and miter gauge. Grasping handle bar, push the stand release pedal with foot and tilt up and forward until the saw rests on the wheels and stand feet.

See Figures 34 & 35.

# MAKING CUTS

**⚠ WARNING:** Failure to comply with the following warnings may result in serious personal injury.

- Never touch the free end of the workpiece or a free piece that is cut off, while the power is on and/or the saw blade is rotating. Blade contact or binding may occur, resulting in a thrown workpiece.
  - When sawing a long workpiece or a panel, use a work support, such as a sawhorse, rollers or outfeed table at the same height as the table surface of the saw.
  - Never try to pull the workpiece back or lift it off the table, turn the switch off, allow the blade to stop, raise the anti-kickback teeth on each side of the riving knife if necessary, and slide the workpiece out.
  - Before connecting the table saw to the power source
- or operating the saw, always inspect the blade guard assembly and riving knife for proper alignment and clearance with the saw blade. Check alignment after each change of beveling angle.
- A rip fence should ALWAYS be used for ripping operations to prevent loss of control and personal injury. Always lock the fence to the rail. NEVER perform a ripping operation freehand.
  - When making bevel cuts, place the fence on the right side of the blade so that the blade is tilted away from the fence and hands. Keep hands clear of the blade and use a push stick to feed the workpiece unless the workpiece is large enough to allow you to hold it more than 6 inches (152 mm) from the table.
  - Before leaving the saw unattended, lock out power switch, or take other appropriate measures to prevent unauthorized use of the saw.

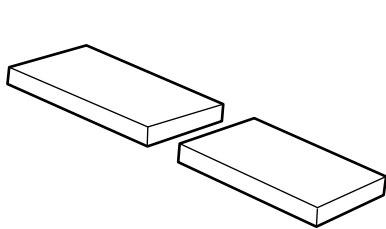

**Cross Cut**

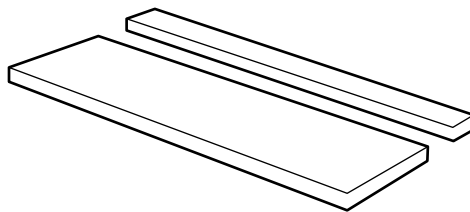

**Rip Cut**

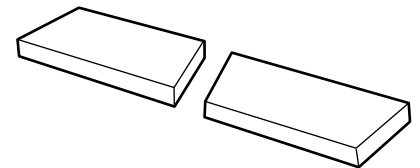

**Mitered Crosscut**

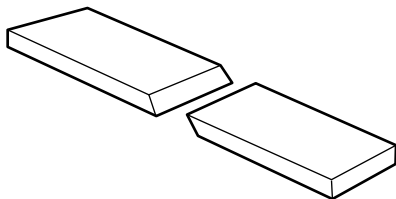

**Beveled Cross Cut**

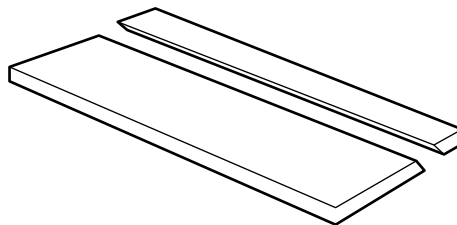

**Beveled Rip Cut**

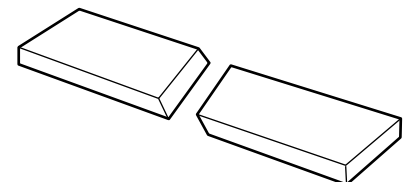

**Compound Miter Cut**

# MAKING CUTS

## RIP CUTS

1. Remove miter gauge.
2. Make sure bevel angle is set to  $0^\circ$ .
3. Set blade to correct height for workpiece.
4. Install rip fence and lock it down parallel with and at desired distance from blade.
5. Keep fingers at least 6 inches from the blade at all times. When the hand cannot be safely out between the blade and the rip fence, select a larger workpiece, or use a push stick and other cutting aids, as needed, to control the workpiece.
6. Make sure the workpiece is clear of the blade (at least 1 inch or 25 mm away) before starting the saw.
7. Turn saw on.
8. Hold the workpiece flat on the table and against the fence (A). The workpiece must have a straight edge against the fence and must not be warped, twisted or bowed. See proper hand position in Figure 36.
9. Let blade build up to full speed before moving workpiece into the blade.
10. Both hands can be used while starting the cut as long as hands remain 6 inches from the blade.
11. Keep the workpiece against the table and fence and slowly feed the workpiece rearward all the way through the saw blade. Do not overload the motor by forcing the workpiece into the blade.
12. Use the push stick and any other cutting aids, as needed, to hold the workpiece against the table and fence, and push the workpiece past the blade. A push stick is included with this saw, and instructions are included to make additional push sticks and other cutting aids.
13. Do not push or hold onto the free or cut-off side of the workpiece.
14. Continue pushing the workpiece until it is clear of the blade. Do not overload the motor by forcing the workpiece into the blade.
15. When cut is complete, turn saw off. Wait for blade to come to a complete stop before removing workpiece from table.

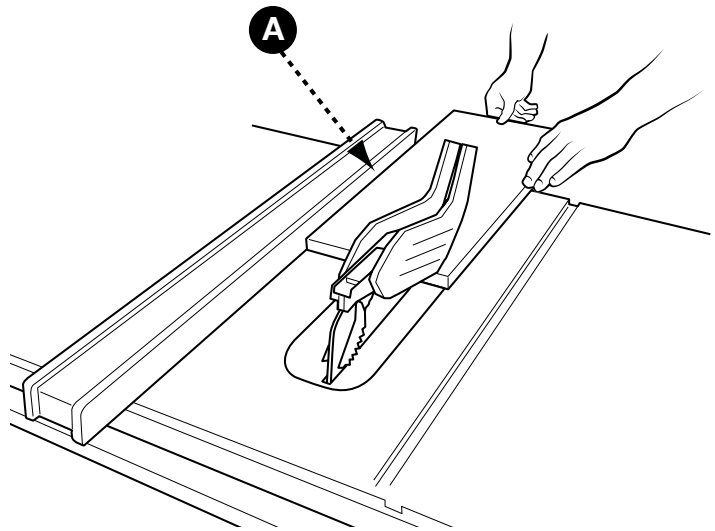

FIGURE 36

## BEVEL RIPPING

Bevel ripping is the same as ripping except the bevel angle (A) is set to an angle other than  $0^\circ$ . When making a bevel rip cut, place the fence on the right side of the blade so that the blade is tilted away from the fence and hands.

See Figure 37.

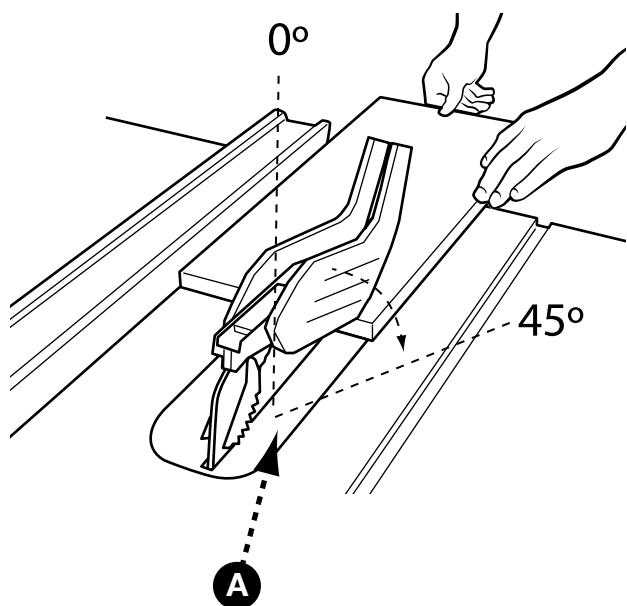

FIGURE 37

# MAKING CUTS (CONTINUED)

## CROSSCUTTING

### ⚠ WARNING:

- **NEVER** use the fence as a guide or length stop when crosscutting, unless you are using the fence as described on page 28 Figure 46 of this manual.
- The cut-off piece must never be confined in any through-sawing (cutting completely through the workpiece) operation—to prevent pinching blade which may result in a thrown workpiece and possibly injury.
- When using a block as a cut-off gauge, the block must be at least 3/4-inch (19mm) thick. It is very important that the rear end of the block be secured in a position where the workpiece is clear of the block before it enters the blade to prevent binding of the workpiece.

You can use the miter gauge in either table slot on non-bevel cuts. To increase surface area of miter gauge face, add an auxiliary face (See Cutting Aids section on page 27 of this manual.)

**To make a crosscut, refer to Figure 38 and follow this process:**

1. Remove rip fence.
2. Make sure bevel angle is set to 0°.
3. Set blade to correct height for workpiece.
4. Place miter gauge in either miter slot.
5. Set miter gauge to 90° and tighten miter gauge lock knob
6. Hands must remain at least 6 inches from blade throughout entire cut. If workpiece is too small to keep hands at least 6 inches away from the blade, select a larger workpiece, or attach an auxiliary face to the miter gauge and attach workpiece to auxiliary face, For instructions about making auxiliary faces, see Cutting Aids section on page 27 of this manual.

7. Make sure the workpiece is clear of the blade - at least 1 inch or 25mm away - before starting the saw.
8. Turn saw on.
9. Let blade build up to full speed before moving workpiece into the blade.
10. Hand closest to blade should be placed on miter gauge lock knob and hand farthest from blade should hold workpiece firmly against the miter gauge face. Do not push or hold onto the free or cut-off side of the workpiece.
11. Slowly feed the workpiece rearward all the way through the saw blade. Do not overload the motor by forcing the workpiece into the blade.
12. When cut is complete, turn saw off. Wait for blade to come to a complete stop before removing cut off piece from table.

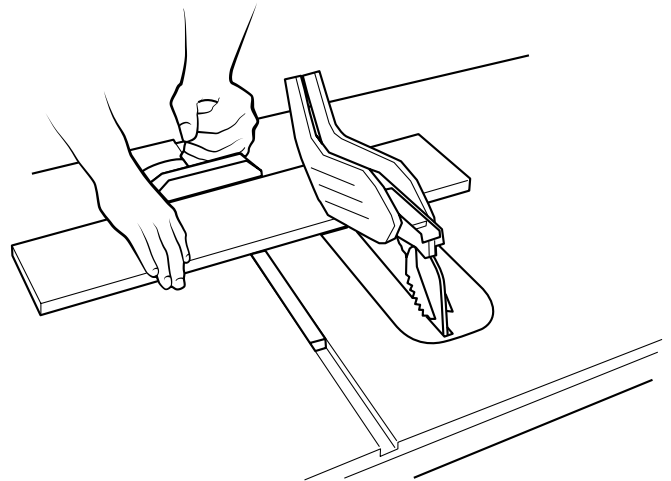

FIGURE 38

## BEVEL CROSSCUTTING

Bevel crosscutting is the same as crosscutting except the bevel angle (A) is set to an angle other than 0°. When making a bevel crosscut, place the miter gauge in the right miter slot so that the blade is tilted away from the gauge and hands. See Figure 39.

## MITER CUTS

Miter cuts are cross cuts with the miter gauge set at an angle other than 90°. Miter gauge can be adjusted to one of the 8 positive stop angles or as desired to an individual angle increment.

### ⚠ WARNING:

- Miter angles more than 45° may force the blade guard assembly into the saw blade causing damage to the blade guard assembly and personal injury. Before starting the motor, test the operation by feeding the workpiece into the blade guard assembly. If the blade guard assembly contacts the blade, place the workpiece under the blade guard assembly but not touching the blade - before starting the motor.

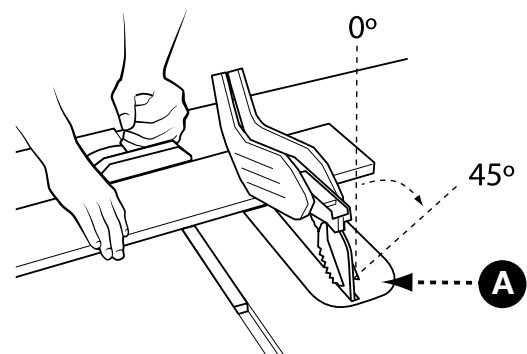

FIGURE 39

- Certain workpiece shapes, such as molding may not lift the blade guard assembly properly. With the power off, feed the workpiece slowly into the blade guard area and until the workpiece touches the blade. If the blade guard assembly contacts the blade, place the workpiece under the blade guard assembly - but not touching the blade - before starting the motor.

# MAKING CUTS (CONTINUED)

## COMPOUND MITER CUTS

This is a combination of bevel crosscutting and mitering. Refer to Figure 40 and follow the instructions for both bevel crosscutting and mitering. Remember to use the right miter slot on the right side of the blade for all bevel cuts.

## LARGE PANEL CUTS

Place workpiece supports at the same height as the saw table behind saw to support the cut workpiece, and alongside (s) of saw, as needed. Depending on shape of panel, use rip fence or miter gauge to control workpiece. If a workpiece is too large to use either a rip fence or a miter gauge, it is too large for this saw.

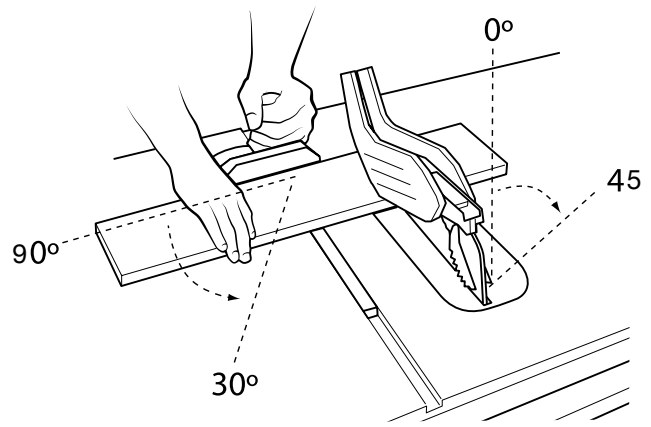

FIGURE 40

## NON-THROUGH CUTS

The use of a non-through cut is essential to cutting grooves, and rabbets. Non-through cuts can be made using a standard blade having a diameter of 10 inches. Non-through cuts are the only type of cuts that should be made without the blade guard assembly installed. Make sure the blade guard assembly is reinstalled upon completion of this type of cut.

### ⚠ WARNING:

- When making non-through cuts, follow all applicable warnings and instructions listed below in addition to those listed above for the relevant through cut.
- When making a non-through cut, blade is covered by workpiece during most of cut. Be alert to exposed blade at start and finish of every cut.

- Never feed wood with hands when making any non-through cuts such as rabbets or grooves. Always use miter gauge, push blocks or push sticks, and featherboards where appropriate.
- In addition to this section, read the appropriate section which describes the type of through or cut. For example, if your non-through cut is a straight cross cut, read and understand the section on straight cross cuts before proceeding.
- Once all non-through cuts are completed, unplug saw and return riving knife to through cut position. Install anti-kickback pawls and blade guard.
- Carefully follow the instructions accompanying any specialized blades for proper installation, set up and operation.

## MAKING A NON-THROUGH CUT

1. Unplug saw.
2. Unlock bevel lock.
3. Adjust bevel angle to 0°.
4. Lock bevel lock.
5. Remove blade guard and anti-kickback pawls.
6. Place riving knife in “lowered” position. See RIVING KNIFE POSITION AND ALIGNMENT Section on page 32.
7. Set blade to correct depth for workpiece.
8. Depending on shape and size of wood, use either rip fence or miter gauge.
9. Plug saw into power source and turn saw on.
10. Let blade build up to full speed before moving workpiece into blade.
11. Always use push blocks, push sticks, and/or featherboards when making non-through cuts to reduce the risk of serious injury.
12. When cut is made, turn saw off. Wait for blade to come to a complete stop before removing workpiece.



# MAKING CUTS

## MAKING A DADO CUT

Dado blades are stacked blades that can be used when making non-through cuts including through cut slots. Dado blades require a special throat plate. Dado blades and throat plates are all sold separately.

### ⚠ WARNING:

- Carefully follow the instructions accompanying the dado blade for proper installation, set up and operation. Additional guides can be found in woodworking and carpentry websites and publications.
- Do not attempt to stack dado blades thicker than 13/16 inch (20.64 mm). Do not use dado blades larger than 8-inches (200 mm) in diameter.
- The riving knife and blade guard assemblies cannot be used when dadoing. They must be removed as described in Riving Knife and Blade Guard Operations section. Use EXTREME care when using the dado without the blade guard assembly and riving knife.
- Use push sticks, hold-downs, jigs, fixtures or feather boards to help guide and control the workpiece when the guard cannot be used.
- Be sure to reinstall the riving knife, anti-kickback pawls blade guard and standard throat plate, and check adjustments when the dado cuts are complete.
- The accessory dado head set throat plate, shown in

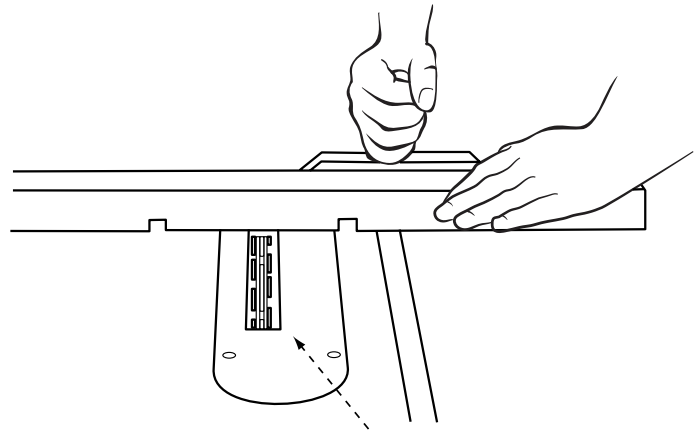

FIGURE 41

Figure 41, must be used in place of the standard throat plate. Be sure the throat plate is level to the table before you proceed.

- Always check the dado blade clearance with other components before plugging in the saw.
- Never attempt to use the dado head in a bevel position.

**NOTE:** The standard outer arbor flange cannot be used with certain dado blade combinations. In those cases, tighten the arbor nut directly against the dado blade set. Save the outer arbor flange for use with other blades and dado combinations.

# CUTTING AIDS AND ACCESSORIES

## PUSH STICK

In order to operate your table saw safely, you must use a push stick whenever the size or shape of the workpiece would otherwise cause your hands to be within 6-inches (152mm) of the saw blade or other cutter. A push stick is included with this saw.

No special wood is needed to make additional pushsticks as long as it is sturdy and long enough with no knots, checks or cracks. A length of approximately 16 inches (400mm) is recommended with a notch that fits against the edge of the workpiece to prevent slipping. It's a good idea to have several push sticks of the same minimum length, 16 inches (400mm), with different size notches for different workpiece thicknesses.

The shape can vary to suit your own needs as long as it performs its intended function of keeping your hands away from the blade. Angling the notch so the push stick can be held at a 20 to 30-degree angle from the saw's table will help you to hold down the workplace while also moving the saw.

To construct a push stick, refer to the layout shown in Figure 42.

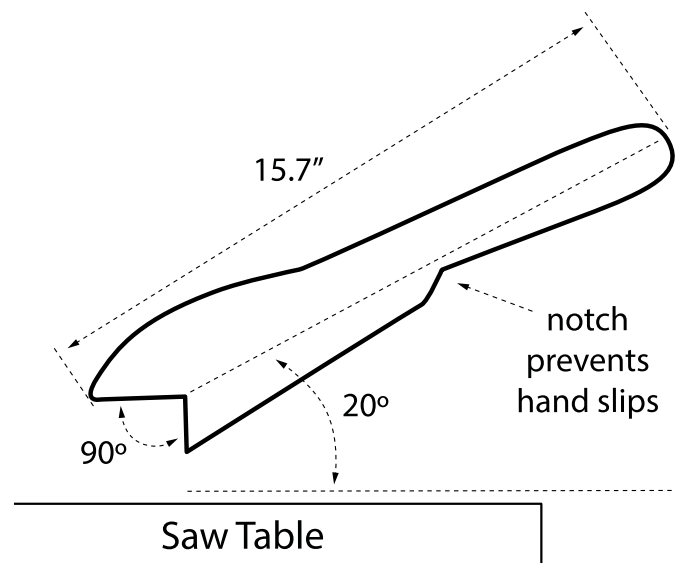

FIGURE 42

## AUXILIARY MITER GAUGE FACING

An auxiliary miter gauge facing is used to increase the surface area of the miter gauge face.

If desired, you can fit the miter gauge with an auxiliary wood facing that should be at least 1-inch (25mm) higher than the maximum depth of cut, and at least as wide as the miter gauge.

This auxiliary wood facing can be fastened to the front of the miter gauge by using (2) M6 or 1/4-20 flat head screws and nuts, placing the nuts into the slots provided in the face of the miter gauge body.

See Figure 43.

Make sure the screws are long enough to secure the facing.

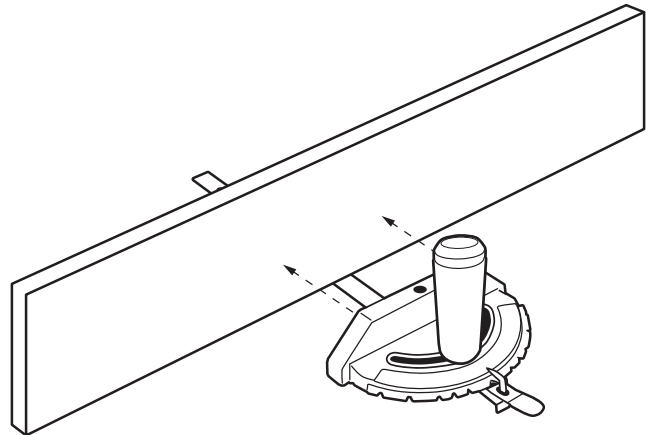

FIGURE 43

**▲ WARNING:** Flat head must be recessed into face of board.

## PUSH BLOCK

1. Select a piece of wood about 4-inches wide, 6-inches long and 1- to 2-inches thick (a cutoff from a 2 by 4 makes a good blank for a push block).
2. Drill a hole in the block and glue in a dowel to use as a handle (you can angle the hole to provide a more comfortable grip on the handle).
3. Glue a piece of rough or soft material such as sandpaper or rubber to the bottom of the block to grip the workpiece (old mouse pads work well).

See Figure 44.

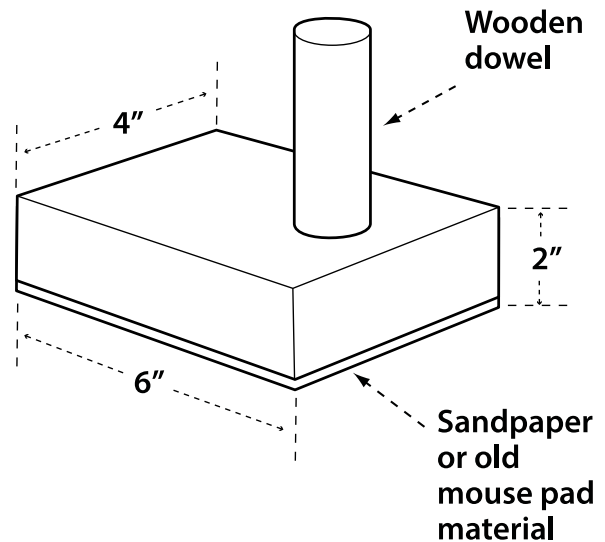

FIGURE 44

# CUTTING AIDS AND ACCESSORIES (CONTINUED)

## FEATHERBOARD

Featherboards are used to keep the workpiece in contact with the fence and table (Figure 45), and help prevent kickback. Featherboards are especially useful when ripping small workpieces and for completing non-through cuts. The end is angled with a series of narrow slots to give a friction hold on the workpiece. It is locked in place on the table or fence with a c-clamp.

**⚠ WARNING:** To avoid binding between the workpiece and the blade, make sure a horizontal feather board presses only on the uncut portion of the workpiece in front of the blade.

Dimensions for making a typical featherboard are shown in Figure 45. Make your featherboard from a straight piece of wood that is free of knots and cracks. Clamp featherboards to the fence and/or table so that the featherboard will hold the workpiece against the fence or table.

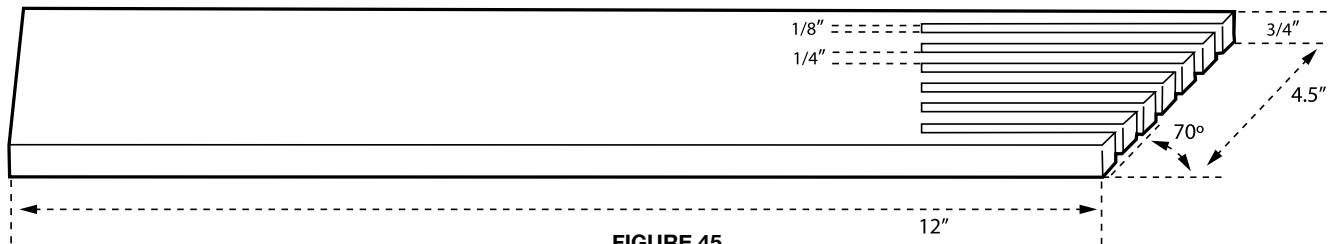

FIGURE 45

## CUT OFF GAUGE

When crosscutting a number of pieces to the same length, you can clamp a block of wood (A) (See Figure 46) to the fence and use it as a cut-off gauge. The block (A) must be at least 3/4-inch (19 mm) thick to prevent the cut off piece from binding between the blade and the fence. Once the cut-off length is determined, lock the fence and use the miter gauge to feed the workpiece into the blade.

**⚠ CAUTION:** Always position the entire cut-off gauge in front of the saw blade.

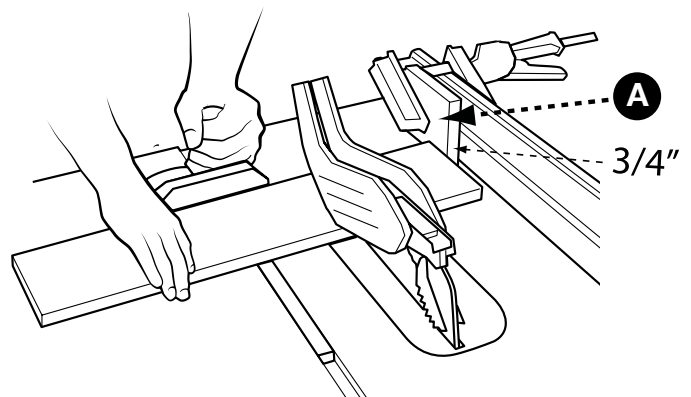

FIGURE 46

## JIGS

Jigs may be created with a variety of special set-ups to control particular workpiece shapes for particular cuts. Guidance on how to make specialized jigs can be found in woodworking and carpentry websites and publications.

**⚠ CAUTION:** Do not attempt to create or use a jig unless you are thoroughly familiar with table saw safety. Do not use any jig that could result in pinching a kerf or jamming the workpiece between the jig and the blade. Incorrect setups may cause kickback which could result in serious injury.

## MAKING ADJUSTMENTS

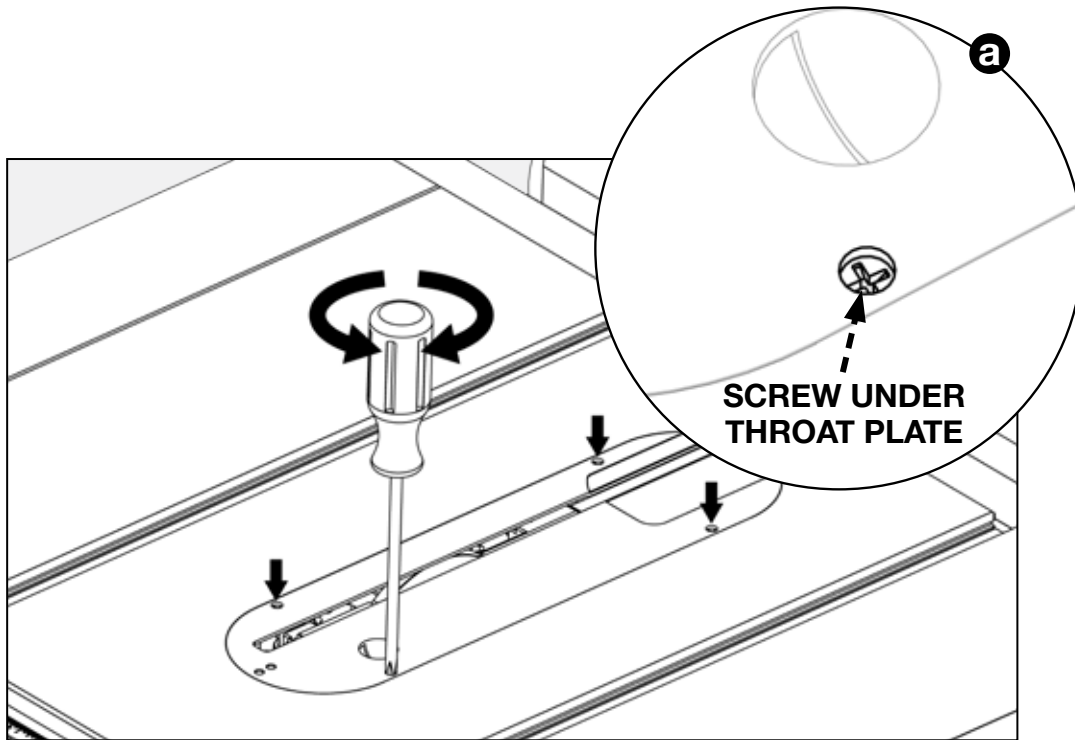

FIGURE 47

### LEVELING THE THROAT PLATE

The front, rear and sides of the throat plate must be level with the surface of the table.

There are four screws pre-assembled to the table that are used to level the throat plate.

If the throat plate is not flush with the surface of the table, adjust these screws to ensure the entire throat plate is flush with the table. They can be accessed and adjusted without removing the throat plate. Do not attempt to mount the throat plate down using the throat plate leveling screws.

See Figures 47 & 47a.

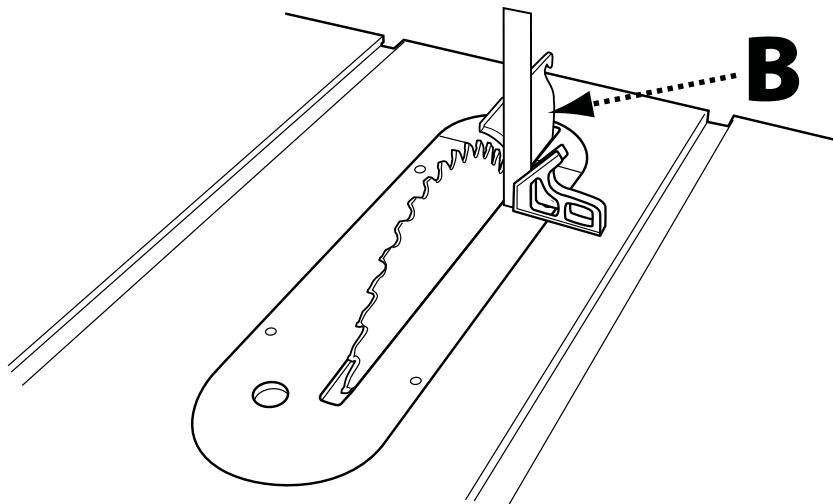

FIGURE 48

### SQUARING THE BLADE VERTICALLY TO THE TABLE

Place a framing square (B) on the table surface and against both blade and riving knife. The framing square should be in full contact with the blade face and riving knife.

See Figure 48.

If it is not square, adjust the 0-degree stop as shown in “Adjusting The Bevel Stops” below.

See Figures 49, 49a, 50 and 50a.

# MAKING ADJUSTMENTS

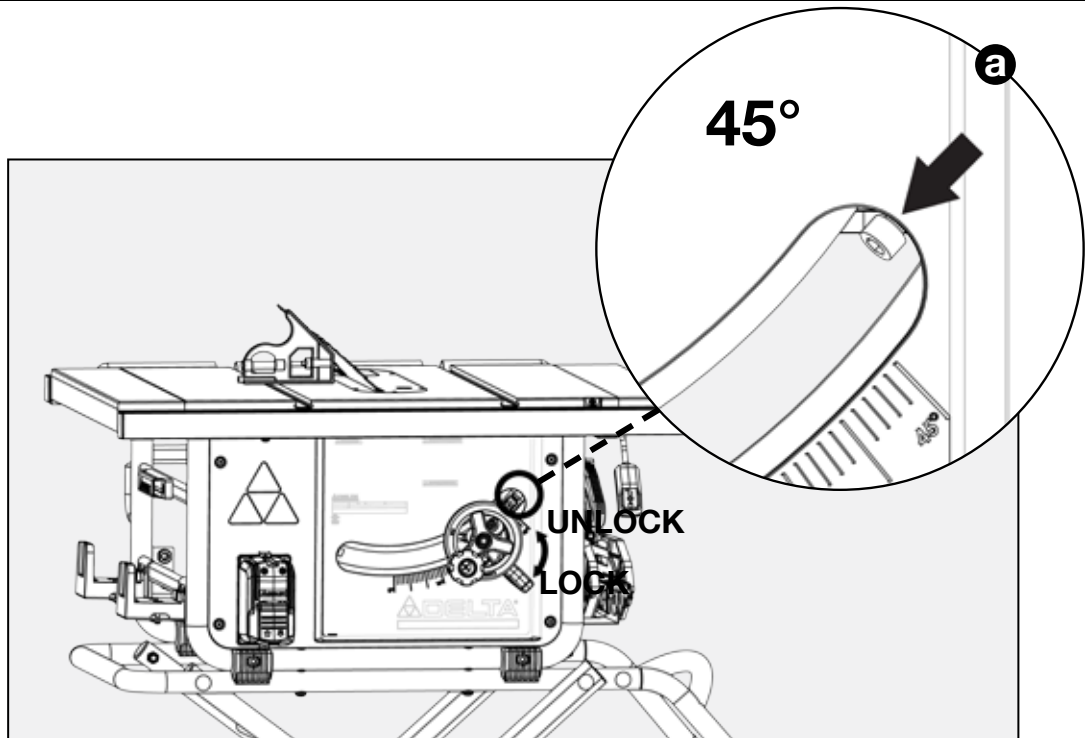

FIGURE 49

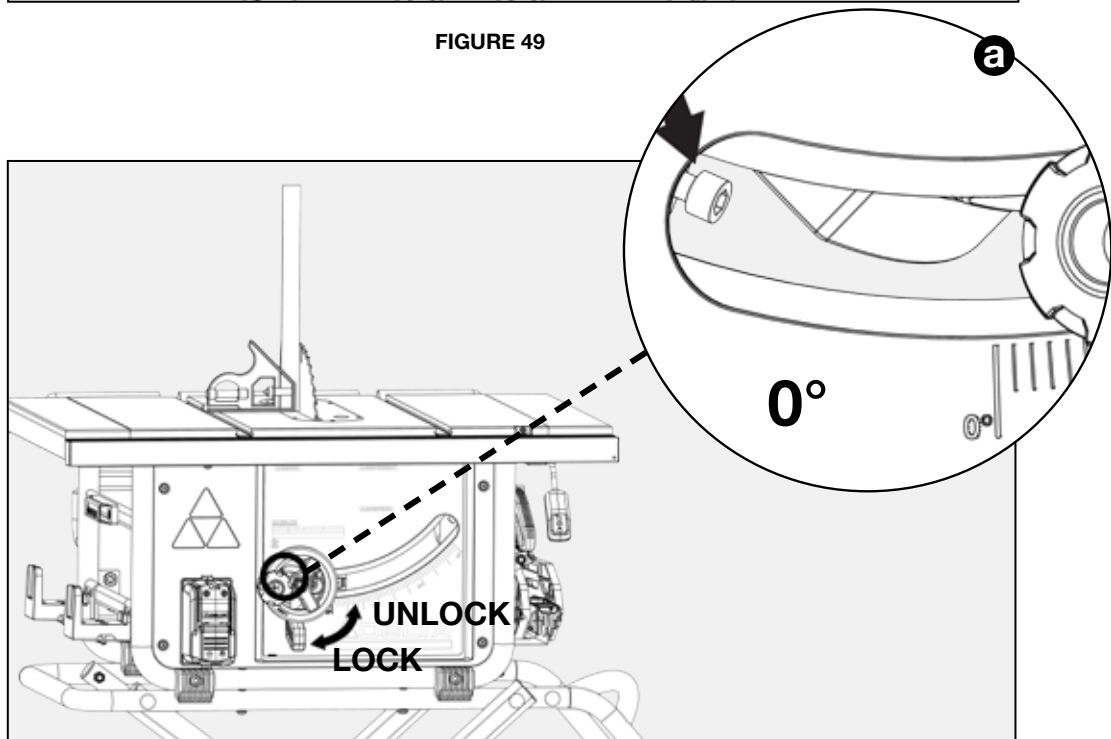

FIGURE 50

## ADJUSTING THE BEVEL STOPS

If the blade is not vertically square with the table, you must adjust the 0-degree positive stop located on the inside of the bevel track at the left end of the bevel track opening as shown in Figures 50 and 50a.

Unlock the bevel/height adjustment locking lever and position the adjustment wheel to the right in order to gain easy access to the 0-degree positive stop. Then lock the adjustment lever.

Turn the 0-degree positive stop set screw to right or left to adjust stop location.

Unlock the adjustment wheel, return the blade to the 0-degree position, making sure it makes contact with the positive stop, and re-lock the adjustment wheel in place.

Recheck the position of the blade to the table surface using a framing square (See “SQUARING THE BLADE VERTICALLY TO THE TABLE” ON THIS PAGE).

Continue repeating previous two steps until the blade is vertically square to the table.

You can use this same procedure in order to check the 45-degree positive stop, located at the far right end of the bevel track, just inside the bevel track opening as shown in Figures 49 & 49a.

# MAKING ADJUSTMENTS

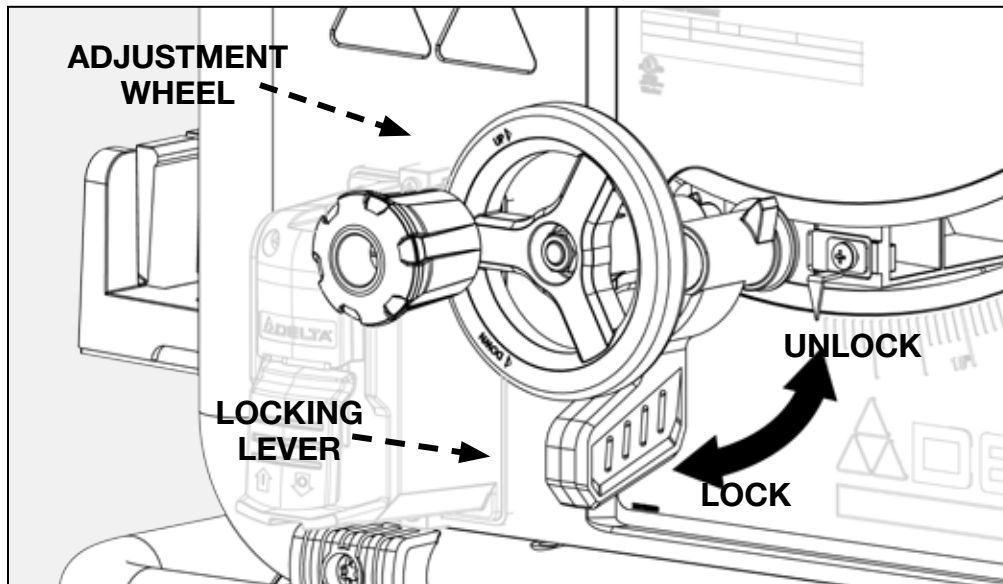

FIGURE 51

## ADJUSTING THE BLADE HEIGHT

For all through cuts, the top of the blade points should be above the workpiece and the bottom of the blade gullets are below the top surface of workpiece.

For non-through cuts, the top of the blade points should be set to the depth of the cut.

To adjust the height of the blade, refer to Figure 51 and do the following:

Make sure the bevel/height adjustment locking lever is in the locked position.

Adjust the blade height by turning the bevel/height adjustment wheel. Clockwise will raise the blade and counterclockwise lowers it.

## CHANGING THE BEVEL

Unlock the bevel/height adjustment locking lever by pulling it into the unlock position.

Holding knob/wheel, slide the bevel indicator to the desired angle.

When the blade is at desired angle, lock the bevel/height adjustment locking lever by pushing it down to the lock position.

See Figure 51.

# MAKING ADJUSTMENTS

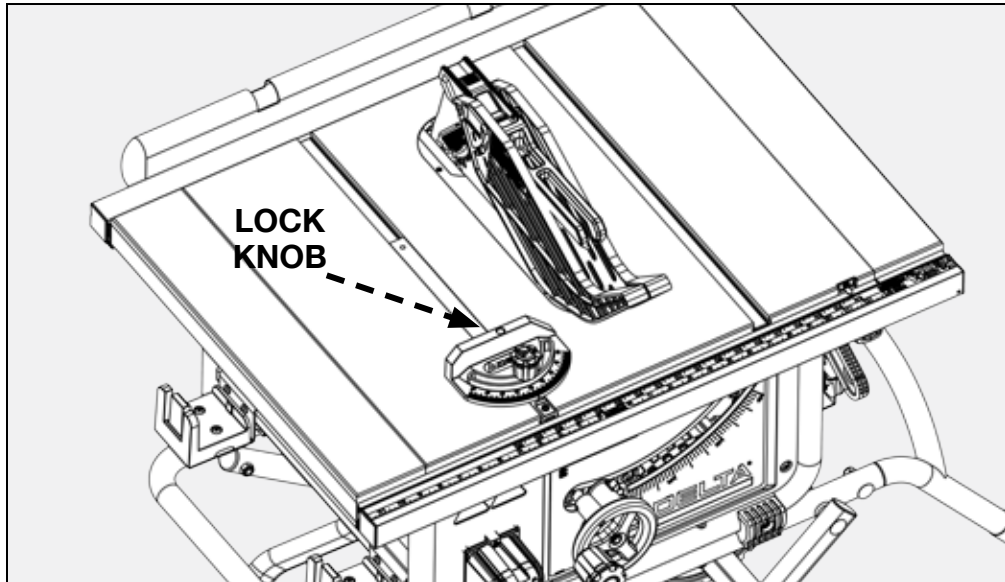

FIGURE 52

## USING THE MITER GAUGE

There are two miter gauge grooves, one on either side of the blade. When making a 90° cross cut, use either groove. For beveled cross cut use the groove on right so that the blade is tilted away from miter gauge and hands.

Loosen the miter gauge lock knob. Rotate the gauge until desired angle on scale is reached. Retighten lock knob.

See Figure 52.

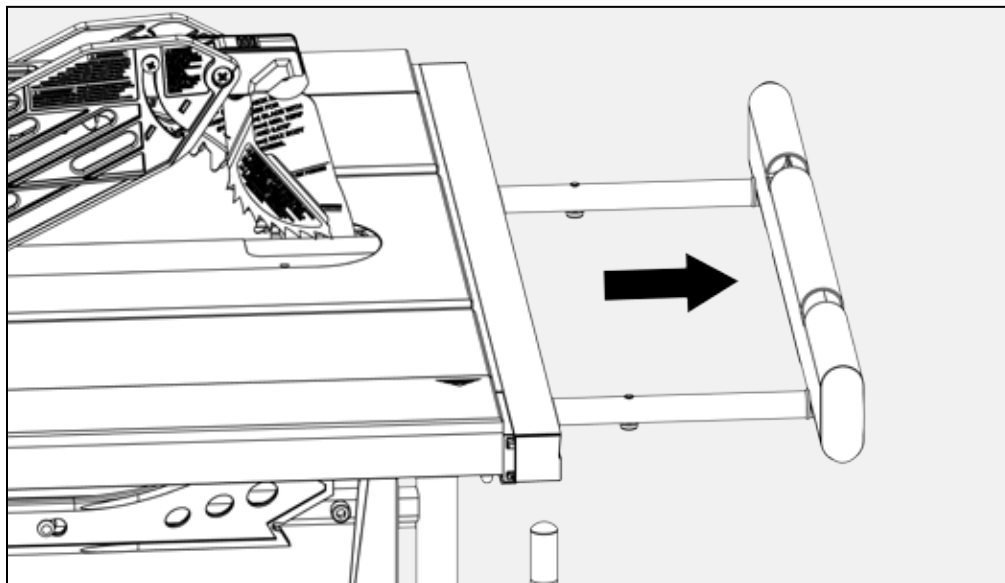

FIGURE 53

## USING THE REAR OUTFEED SUPPORT

The out-feed support slides out to provide additional support for cutting long work pieces.

Ensure the power switch is in the OFF position. From the rear of the saw, grasp the out-feed support with both hands until it is fully extended.

See Figure 53.



# MAKING ADJUSTMENTS

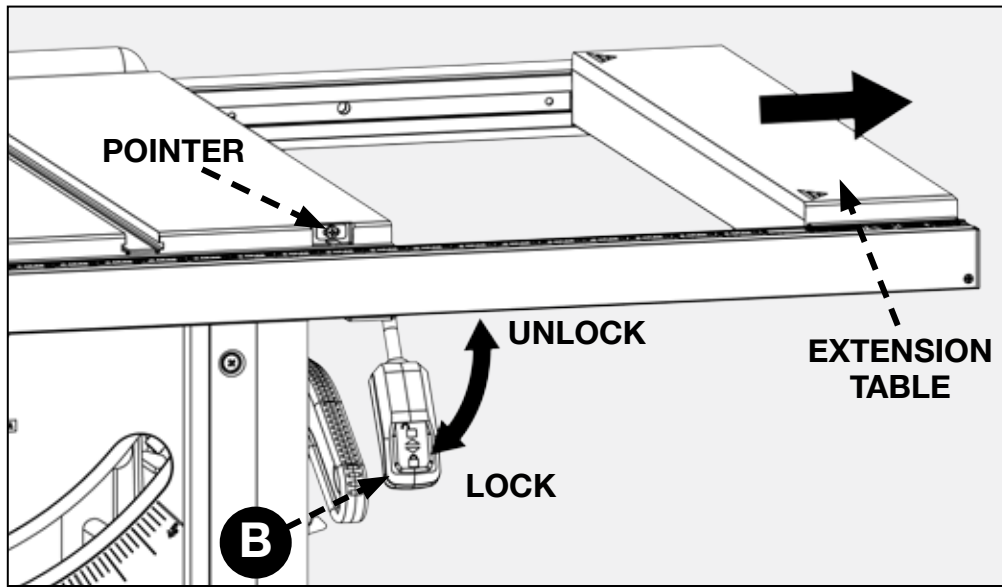

FIGURE 54

## USING THE RIGHT HAND TABLE EXTENSION

The table extension, located on the right side of the table, enables you to increase the width of the saw table to accommodate oversized workpieces.

To use the table extension, refer to Figure 54 and do the following:

Release the table extension lock (B) by moving it up. Slide side table extension out to the right. Use the blue pointer on the top scale to determine desired distance. When extension table is set to desired width, push lock lever to the lock position.

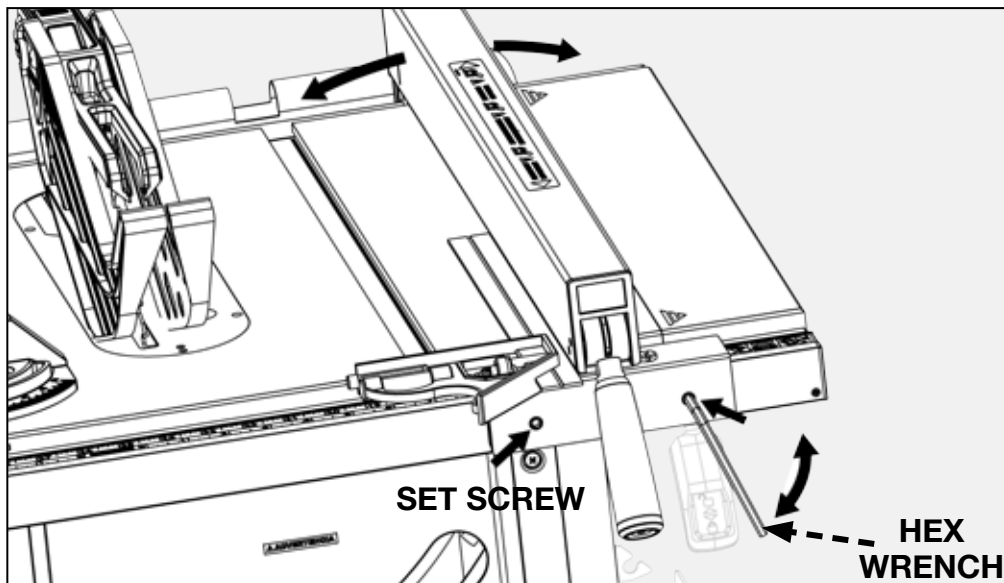

FIGURE 55

## RIP FENCE ADJUSTMENTS

To adjust rip fence so it is parallel to the blade, make adjustments to the set screws on the front of the fence as shown in Figure 55.



# MAKING ADJUSTMENTS

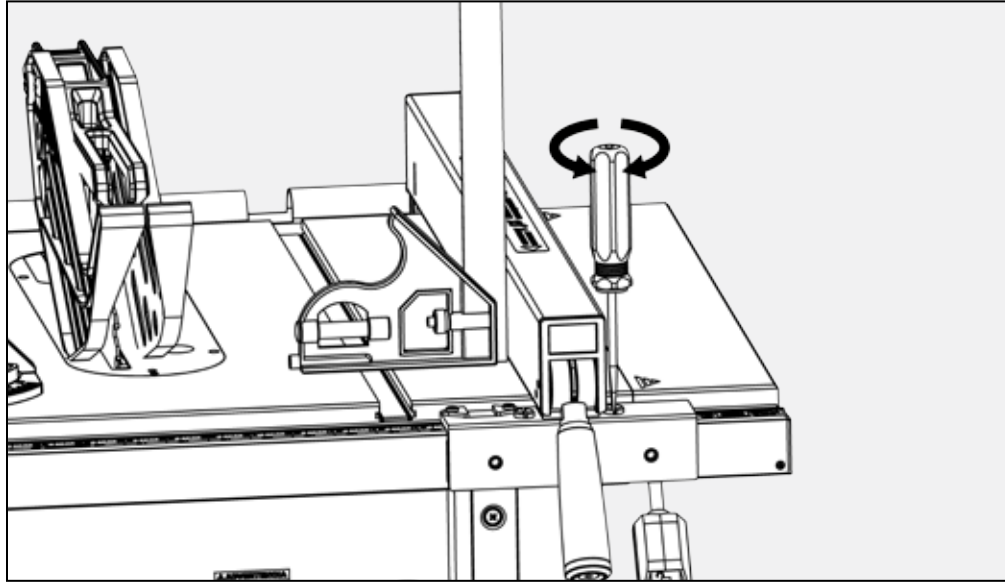

FIGURE 56

To adjust the rip fence so it is perpendicular to the table, make adjustments to the nylon screws on the top of the rip fence “T” as shown in Figure 56.

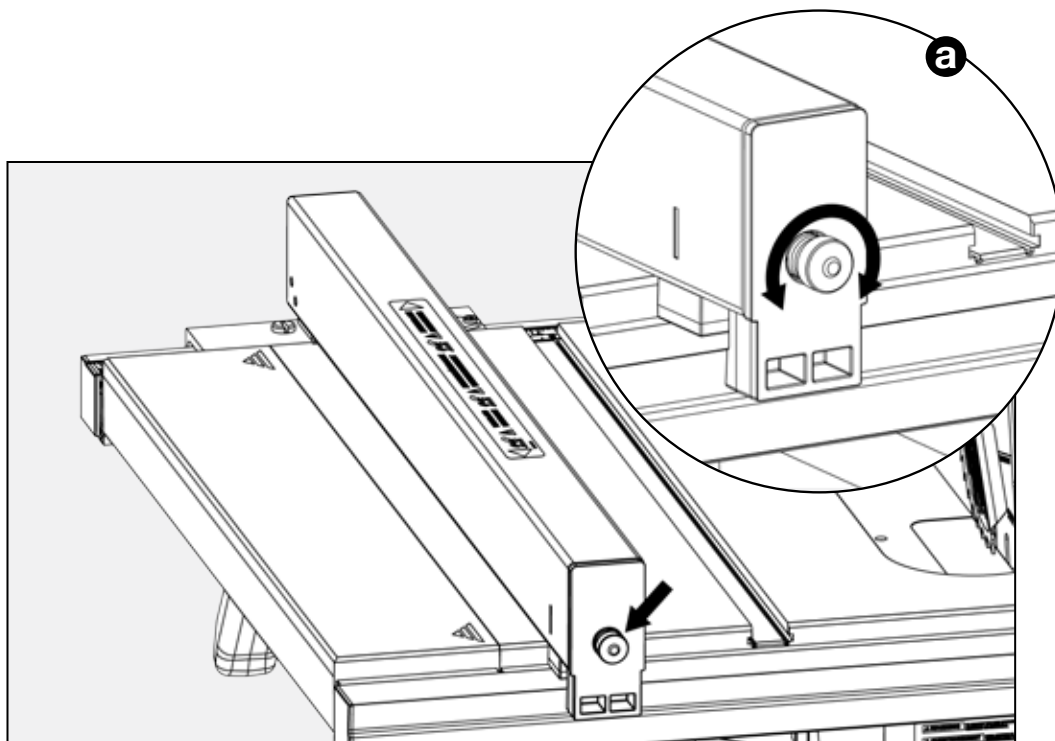

FIGURE 57

To make adjustments to clamping pressure for rip fence, adjust screw on back of fence to the right to tighten and to the left to loosen clamping pressure.

See Figures 57 & 57a.

# RIVING KNIFE POSITION AND ALIGNMENT

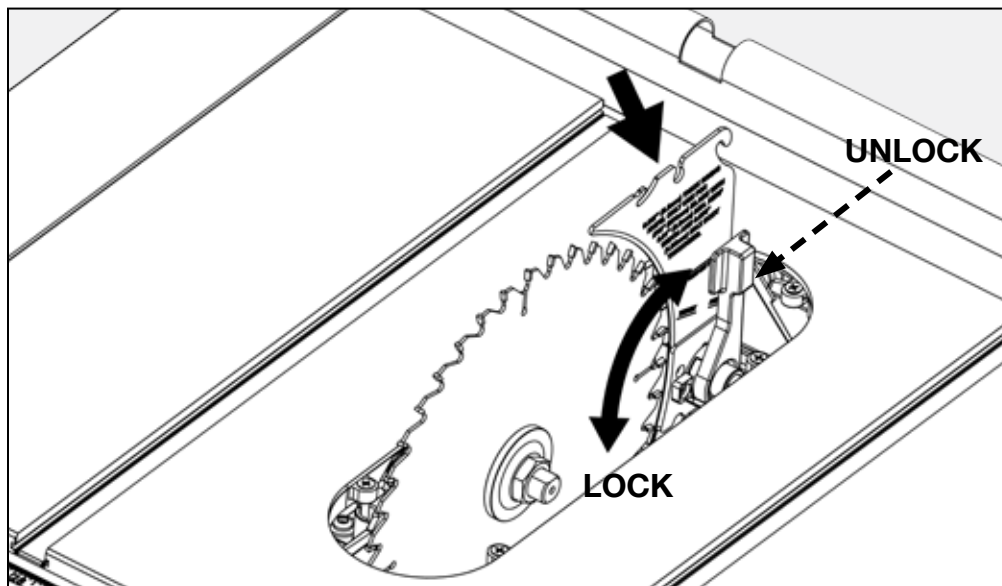

FIGURE 58

## LOWERING THE RIVING KNIFE

Remove throat plate.

1. With the blade assembly to the highest possible position, carefully reach alongside the blade and raise the riving knife locking lever up to unlock the riving knife.
2. Gently move the riving knife to the right to release it from the lock pins in the riving knife assembly.
3. Slide the riving knife down and backward until you feel the lock pins engage the riving knife in the “Non-Thru Cut” position. When properly aligned in this position, the “Non-Thru Cut” line on the riving knife will be parallel to and level with the table. See Figure 59 on page 33.
4. Return the riving knife lock lever to the lock position.
5. Make sure the riving knife is securely installed and properly aligned with the blade.

To raise riving knife to “Thru-Cut” position repeat steps 1-5 and on step 3 raise riving knife up and forward.

Reinstall throat plate.

# RIVING KNIFE POSITION AND ALIGNMENT

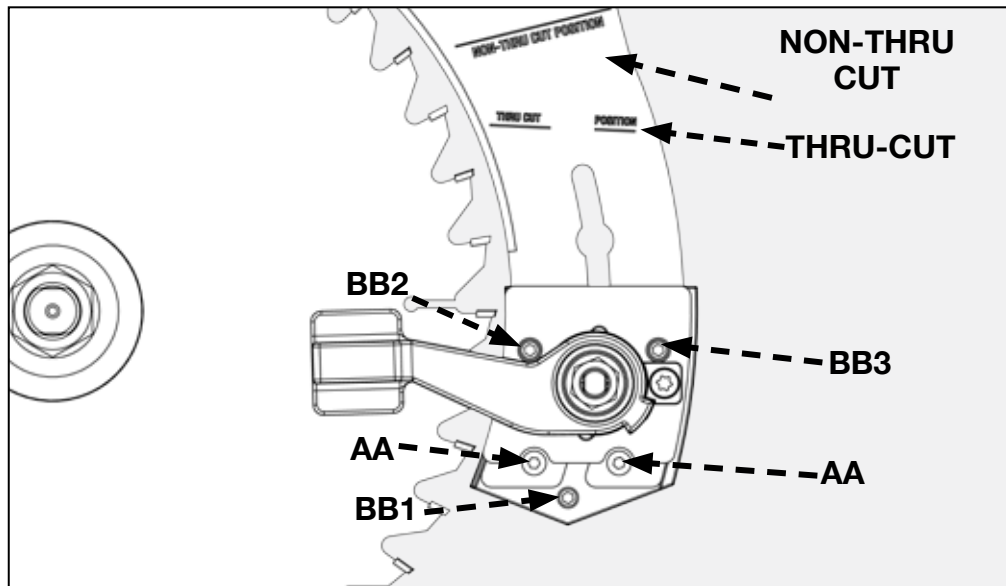

FIGURE 59

Location point for NON-THRU CUT POSITION

**NOTE:** Riving knife is located in this position for “NON-THRU” cuts and is also in this position when packaged for shipment.

Location point for THRU CUT POSITION as shown in Figure 59. (Operator should adjust the riving knife to this position when making “THRU” cuts.)

**(NOTE:** You must locate the riving in THRU CUT position prior to making any alignment adjustments to the riving knife alignment to the blade.)

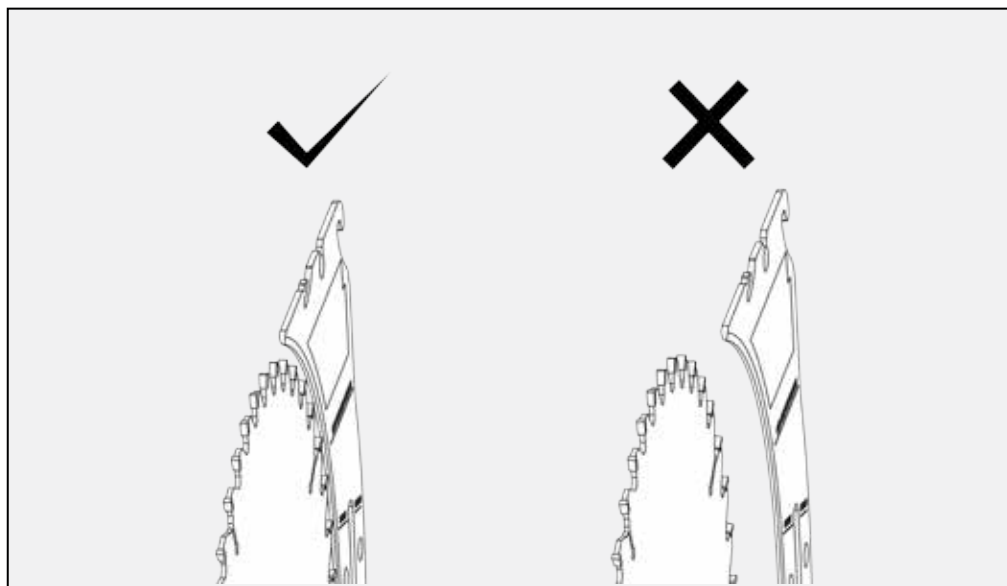

FIGURE 60

## RIVING KNIFE ALIGNMENT

### Parallel Alignment

The plane of the riving knife is parallel to the plane of the blade but the riving knife and the blade are not in line with each other.

If a parallel adjustment is required use Figure 59 and Figure 60 to make the following adjustments:

1. Loosen the two hex socket head screws (AA)
2. Tighten or loosen the adjustment screw (BB1) to adjust the datum line of the riving knife to be aligned with the blade.
3. Adjust set screw (BB2) and (BB3), to assist with the alignment of the riving knife to be parallel to the blade.
4. Tighten hex socket head screws (AA).

# RIVING KNIFE POSITION AND ALIGNMENT

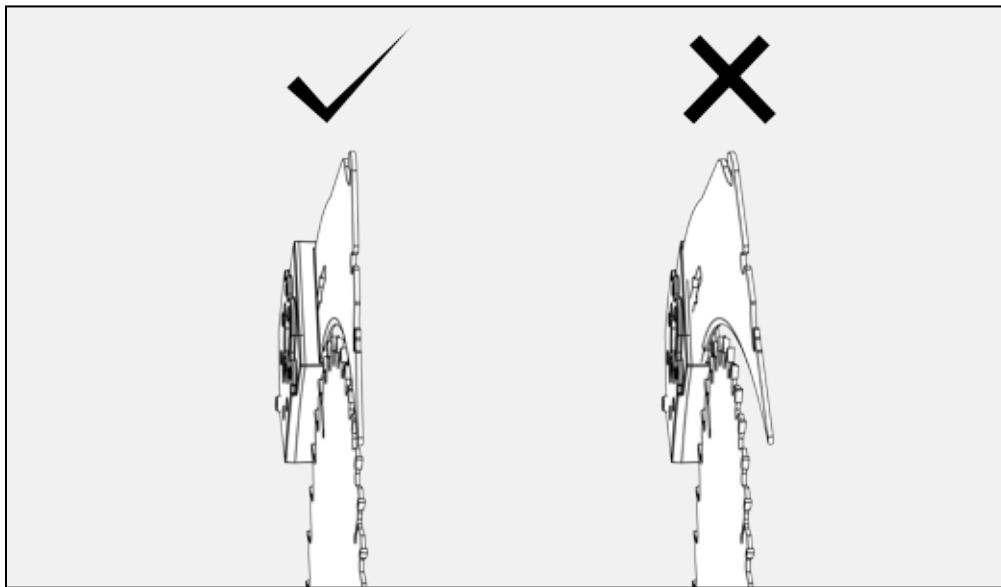

FIGURE 61

## Horizontal Alignment

The plane of the riving knife appears to be twisted in comparison to the plane of the blade. (Can be seen looking straight down on the blade and riving knife.)

If the riving knife has horizontal misalignment, adjust as follows using Figure 59 and Figure 61.

1. Loosen the two hex socket head screws (AA)
2. Adjust screw (BB2) to align the riving knife to the blade, if still out of alignment then adjust (BB3) until proper alignment is achieved. Do not adjust (BB1).
3. Tighten screws (AA).

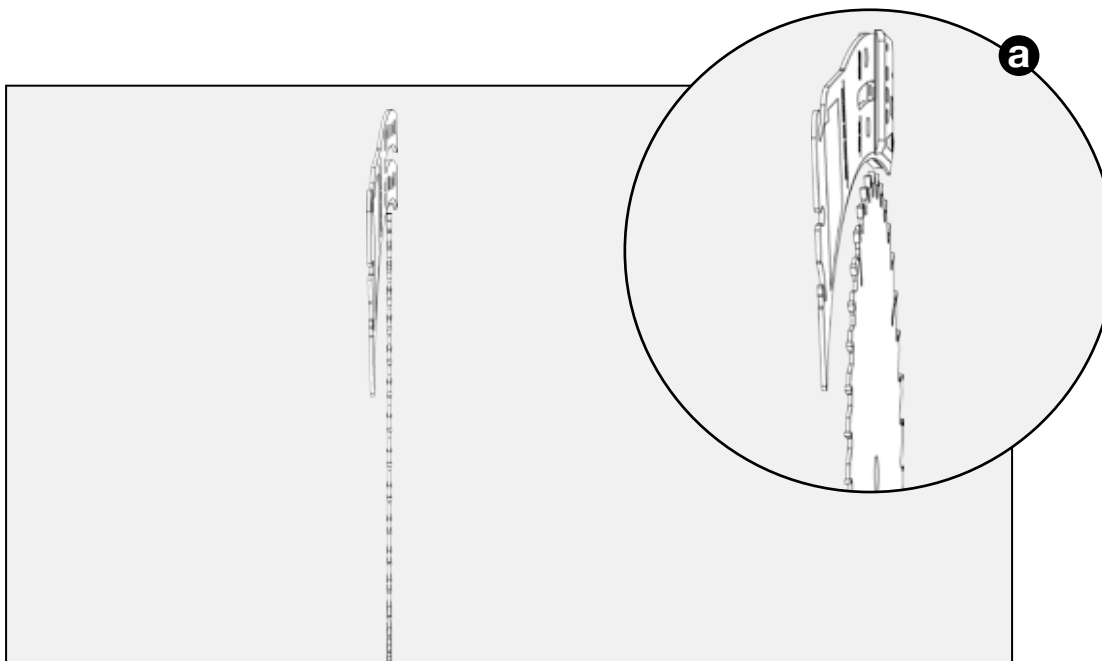

FIGURE 62

## Vertical Alignment

The plane of the riving knife appears to be twisted in comparison to the plane of the blade from the bottom of the riving knife to top of the riving knife. (Can be seen looking from the front of the saw.)

If the riving knife has vertical misalignment, adjust as follows using Figure 59 and Figure 62.

1. Loosen the two hex socket head screws (AA)
2. Make adjustments to (BB2) and (BB3), to align riving knife to the blade. No adjustment is needed for (BB1).
3. Tighten screws (AA).

# MAINTENANCE

**⚠ WARNING:** To reduce the risk of injury, turn unit off and disconnect it from power source before cleaning or servicing, before installing and removing accessories, before adjusting and when making repairs. An accidental start-up can cause injury.

## KEEP MACHINE CLEAN

Periodically blow out all air passages with dry compressed air. All plastic parts should be cleaned with a soft damp cloth. NEVER use solvents to clean plastic parts. They could possibly dissolve or otherwise damage the material.

**⚠ WARNING:** Wear certified safety equipment for eye, hearing and respiratory protection while using compressed air.

## MAINTENANCE REMINDERS

**⚠ WARNING:**

Wear certified safety equipment for eye, hearing and respiratory protection while using compressed air.

Specific areas which require regular maintenance include:

**RIVING KNIFE CLAMP PLATE:** Keep this area free of dust and debris buildup. Blow out area regularly with compressed air.

**NOTE:** If the riving knife clamp can't move freely, have the saw serviced by authorized DELTA® Power Equipment Corporation service center personnel.

**WORM GEARS:** Keep the bevel gears free of dust and debris buildup. Blow out area regularly with compressed air. Use a lithium-based multipurpose grease as needed on these gears.

**CLEAN SAWDUST BUILDUP OUT OF CABINET PERIODICALLY:** **NOTE:** Debris can also be removed from the saw from below the throat plate, inside the dust port.

# TROUBLESHOOTING

For assistance with your machine, visit our website at [www.DeltaMachinery.com](http://www.DeltaMachinery.com) for a list of service centers or call DELTA® Power Equipment Corporation Customer Care at 1-800-223-7278.

## FAILURE TO START

If your machine fails to start, check to make sure the prongs on the cord plug are making good contact in the receptacle, and check reset button on power switch housing. Also, check for blown fuses or open circuit breakers in your power line.

# ACCESSORIES

A complete line of accessories is available from your DELTA® Supplier, DELTA® Factory Service Centers and Delta® Authorized Service Centers. Please visit our web site at [www.DeltaMachinery.com](http://www.DeltaMachinery.com) for an online catalog or for the name or your nearest supplier.

**⚠ CAUTION:** Since accessories other than those offered by DELTA® have not been tested with this product, use of such accessories could be hazardous. For safest operation, only DELTA® recommended accessories should be used with this product.

# WARRANTY

To register your tool for warranty service visit our website at [www.DeltaMachinery.com](http://www.DeltaMachinery.com).

## Five Year Limited New Product Warranty

DELTA® will repair or replace, at its expense and at its option, any new DELTA® machine, machine part, or machine accessory which in normal use has proven to be defective in workmanship or material, provided that the customer returns the product prepaid to a DELTA® factory service center or authorized service station with proof of purchase of the product within five years and provides DELTA® with reasonable opportunity to verify the alleged defect by inspection. For all refurbished DELTA® product, the warranty period is 180 days. DELTA® will not be responsible for any asserted defect which has resulted from normal wear, misuse, abuse or repair or alteration made or specifically authorized by anyone other than an authorized DELTA® service facility or representative. Under no circumstances will DELTA® be liable for incidental or consequential damages resulting from defective products. Some states do not allow the exclusion or limitation of incidental or consequential damages, so the above limitation or exclusion may not apply to you. This warranty is DELTA®'s sole warranty and sets forth the customer's exclusive remedy, with respect to defective products; all other warranties, express or implied, whether of merchantability, fitness for purpose, or otherwise, are expressly disclaimed by DELTA®. For further detail of warranty coverage and warranty repair information, visit [www.DeltaMachinery.com](http://www.DeltaMachinery.com) or call 1-800-223-7278. This warranty gives you specific legal rights and you may have other rights which vary in certain states or provinces.

**LATIN AMERICA:** This warranty does not apply to products sold in Latin America. For products sold in Latin America, call the local company or see website for warranty information.

## PARTS, SERVICE AND WARRANTY ASSISTANCE

All DELTA® machines and accessories are manufactured to high quality standards and are serviced by a network of DELTA® Authorized Service Centers. To obtain additional information regarding your DELTA® quality product or to obtain parts, service, warranty assistance, or the location of the nearest service center, please call 1-800-223-7278.

### REPLACEMENT PARTS

Use only identical replacement parts. For a parts list or to order parts, visit our website at [www.DeltaMachinery.com](http://www.DeltaMachinery.com). You can also order parts from your Authorized Warranty Service Center or by calling Customer Support at 1-800-223-7278 to receive personalized support from one of our highly-trained representatives.

### FREE WARNING LABEL REPLACEMENT

If your warning labels become illegible or are missing, call 1-800-223-7278 for a free replacement.



**POWER EQUIPMENT CORPORATION**

2651 New Cut Road  
Spartanburg, SC 29303  
(800) 223-7278  
[www.DeltaMachinery.com](http://www.DeltaMachinery.com)

Copyright © 2016 DELTA® Power Equipment Corporation DPEC004331 - 03-28-16

Rev Date: 06-06-16



## Free Manuals Download Website

<http://myh66.com>

<http://usermanuals.us>

<http://www.somanuals.com>

<http://www.4manuals.cc>

<http://www.manual-lib.com>

<http://www.404manual.com>

<http://www.luxmanual.com>

<http://aubethermostatmanual.com>

Golf course search by state

<http://golfingnear.com>

Email search by domain

<http://emailbydomain.com>

Auto manuals search

<http://auto.somanuals.com>

TV manuals search

<http://tv.somanuals.com>