



brother®

ELECTRONIC TYPEWRITER

**EM-550**

**USER'S GUIDE**

ENGLISH



# BROTHER EM-550 ELECTRONIC TYPEWRITER

Please record in the blank space below the MODEL NO. and SERIAL NO. of this typewriter. The MODEL NO. and SERIAL NO. are located on the back of the typewriter.

MODEL NO. \_\_\_\_\_ SERIAL NO. \_\_\_\_\_

Please keep these numbers in a safe place for possible future reference.

## FCC NOTICE

This equipment generates and uses radio frequency energy and if not installed and used properly, that is, in strict accordance with the manufacturer's instructions, may cause interference to radio and television reception. It has been type tested and found to comply with the limits for a Class B computing device in accordance with the specifications in Subpart J of Part 15 of FCC Rules, which are designed to provide reasonable protection against such interference in a residential installation. However, there is no guarantee that interference to radio or television reception, which can be determined by turning the equipment off and on will be avoided. The user is encouraged to try to correct the interference by one or more of the following measures:

- Reorient the receiving antenna
- Relocate the computer with respect to the receiver
- Move the computer away from the receiver
- Plug the computer into a different outlet so that the computer and receiver are on different branch circuits.

If necessary, the user should consult the dealer or an experienced radio / television technician for additional suggestions. The user may find the following booklet prepared by the Federal Communications Commission helpful: "How to Identify and Resolve Radio-TV Interference Problems". This booklet is available from the US Government Printing Office, Washington, D.C., 20402, Stock No. 004-000-00345-4.

## COPYRIGHT NOTICE

The spelling correction software is licensed from Houghton Mifflin under U.S. Patent No. 4,580,241 and No. 4,730,269. Copyright © 1985, 1987 Houghton Mifflin. all rights reserved. Reproduction or disassembly of embodied programs or Databases prohibited. Based upon The American Heritage Dictionary.



# Table of Contents

## CHAPTER 1

INTRODUCTION	1
Features	1
General Overview	2
Keyboard	3
SETTING UP YOUR TYPEWRITER	4
Paper Support Assembly	4
Acoustic Cover	5
Margin scale	5
Glare-proof plate	5
Top Cover	6
Power	7
Installing the lithium battery	7
Power switch/Diagnostics	8
Cassette Daisy Wheel	9
Cassette Ribbon	11
Correction Tape	12

## CHAPTER 2

THE DISPLAY	14
Status Display	15
Special Display Code Table	15
Display Operations	16
In typewriter mode	16
In word processor mode	16

## CHAPTER 3

BASIC TYPING FUNCTIONS	17
Setting the Impact	17
Selecting the Keyboard	17
Dead keys	18
Extra keys	18
Setting the Line Spacing	18
Setting the Typing Pitch	19
Code Key	19
Auto Paper Insert	19
Manual paper insert	21
Paper thickness control	21
Setting the Starting and Ending Lines	22
Starting line	22
Ending line	22
Page end	22
Setting Margins	23
Pre-set margins	23
Left margin	23
Right margin	23
Margin release	23
Setting Tabs	24
Normal tabs	24
Decimal tabs	24
Tab clear	25
All tab clear	25

Typing Upper Case Characters	26
Backspacing	26
Simple backspace	26
Express backspace	27
Backspace 1	27
Permanent backspace	27
Repeat Function	27
Self repeat	27

## CHAPTER 4

ADVANCED TYPING FUNCTIONS	28
Bold	28
Auto Underline	28
Expand	29
Carrier Return	29
Auto carrier return	29
Hot Zone	30
Permanent Spaces and Hyphens	30
Centering	31
Centering between margins	31
Centering between tabs	32
Right Margin Flush	33
Justification	34
Indentation	35
Line indent	35
Paragraph indent	35
Indent clear	35
Framing	36
Corrections	38
Automatic correction	38
Manual correction	39
Correcting justified and centered text	40
Word out	40
Backspace 1 and word out	41
Line out	43
Relocation	43
Index/Reverse Index	44
Micro index/micro reverse index	44

## CHAPTER 5

MEMORY FUNCTIONS	45
Backup Battery	45
Line Format Memory	46
Storing a line format in memory	46
Calling a line format from memory	46
Page Format Memory	47
Storing a page format in memory	47
Calling a page format from memory	47
Utilizing a called out page format	47
Page format clear	48
Page format all clear	48
Clearing the Backup Memory	48

## CHAPTER 6

### DISPLAY MODE 49

- Line by Line Processing 49
- Cursor and Display Functions 50
  - Cursor left and right 50
  - Express cursor left and right 50
- Corrections in Display Mode 50
  - Overwrite 50
  - Insertion 51
  - Deletion 51
  - Word out 51
  - Line out 51
- Functions Requiring a Special Display 52

## CHAPTER 7

### WORD PROCESSOR 54

- File Creation 55
  - Text file 55
  - Phrase file 56
  - Inserting a phrase file into a text file 57
  - Changing the line format in a text file 57
- File Editing 59
  - Cursor and display movement 59
  - Selecting a file for editing 59
  - Search function 60
  - Replace function 61
  - Block definition 62
  - Block move 63
  - Block copy 63
  - Block deletion 63
  - Adding and printing text at the end of a file 63
- Layout Functions 64
  - Return 64
  - Tabs 64
    - Decimal tabs 65
    - Line indent 65
    - Paragraph indent 66
    - Indent clear 66
    - Centering 66
    - Right margin flush 67
    - Stop codes 67
    - Page end setting 68
- Printing a File 68
  - Bidirectional printing 69
  - Auto return 69
  - Page end 69
  - Printing a file during CREATE-N, EDIT 69
- Editing During Printing 70
  - Using the step function 70
  - Stop codes 70
  - Using the skip function 70
  - Text replacement during printing 71
- Deleting a Text or Phrase File 71
  - Clearing all the memory 71

SPELLING CHECKER	72
Using the Spell Check Function	72
User Dictionary	73
Adding a word to the user dictionary	73
Removing words from the user dictionary	74
Printing the User Dictionary	75
Word Scan Mode	75
Find	77

## APPENDIXES

OPTIONAL ACCESSORY	78
MAINTENANCE	79
TROUBLESHOOTING	80
SPECIFICATIONS	82
QUICK REFERENCE FOR KEY FUNCTIONS	83
INDEX	87



# Chapter 1

---

## INTRODUCTION

Congratulations on becoming the proud owner of a Brother EM-550 electronic typewriter! We are confident that the unsurpassed quality and superb performance of this electronic typewriter will more than satisfy your every typing need. In fact, we can assure you that the outstanding operating features of this electronic typewriter will remove the "chore" from the typewriting task and turn it into one of ease and simplicity, making your day go that much more pleasantly!

## Features

The outstanding features of the Brother EM-550 will make typing on this electronic typewriter the highlight of your working day.

- **80 column x 2 line display**
- **Low-profile keyboard**
- **Standard, international and symbol keyboard selection**
- **1, 1-1/2, 2 line spacings**
- **10, 12, 15 typing pitches**
- **Impact selector**
- **Automatic paper insert**
- **Start/end line set**
- **Caps lock**
- **Paper thickness control**
- **Four backspace functions**
- **Tabulation**
- **Decimal tabulation**
- **Line and paragraph indent**
- **Automatic carrier return**
- **Repeat typing for character keys**
- **Right margin flush**
- **Right margin justification**
- **Framing**
- **Bold typing**
- **Expand typing**
- **Automatic underlining**
- **Index/reverse index**
- **Micro index/micro reverse index**
- **Automatic centering**
- **1-line correction memory**
- **Automatic relocation**
- **Word out**
- **Line out**
- **Backup memory**
- **Cursor function**
- **Text /phrase memory**
- **Line format memory**
- **Page format memory**
- **Line by line mode**
- **Page end set**
- **Block copy, move, delete**
- **Insert/overwrite**
- **Word search**
- **Word replace**
- **Spelling checker**
- **Interface connectability\***

\*: Interface is optionally available.

### Self demonstration printing

A demonstration program has been built into this typewriter. To operate this program, turn on the typewriter and insert a sheet of paper, hold down the **SHIFT** key and press the **PITCH** key in the direct type mode. To cancel the printing, press the **SPACEBAR** or **END** key and the typewriter returns to the direct type mode.

# General Overview

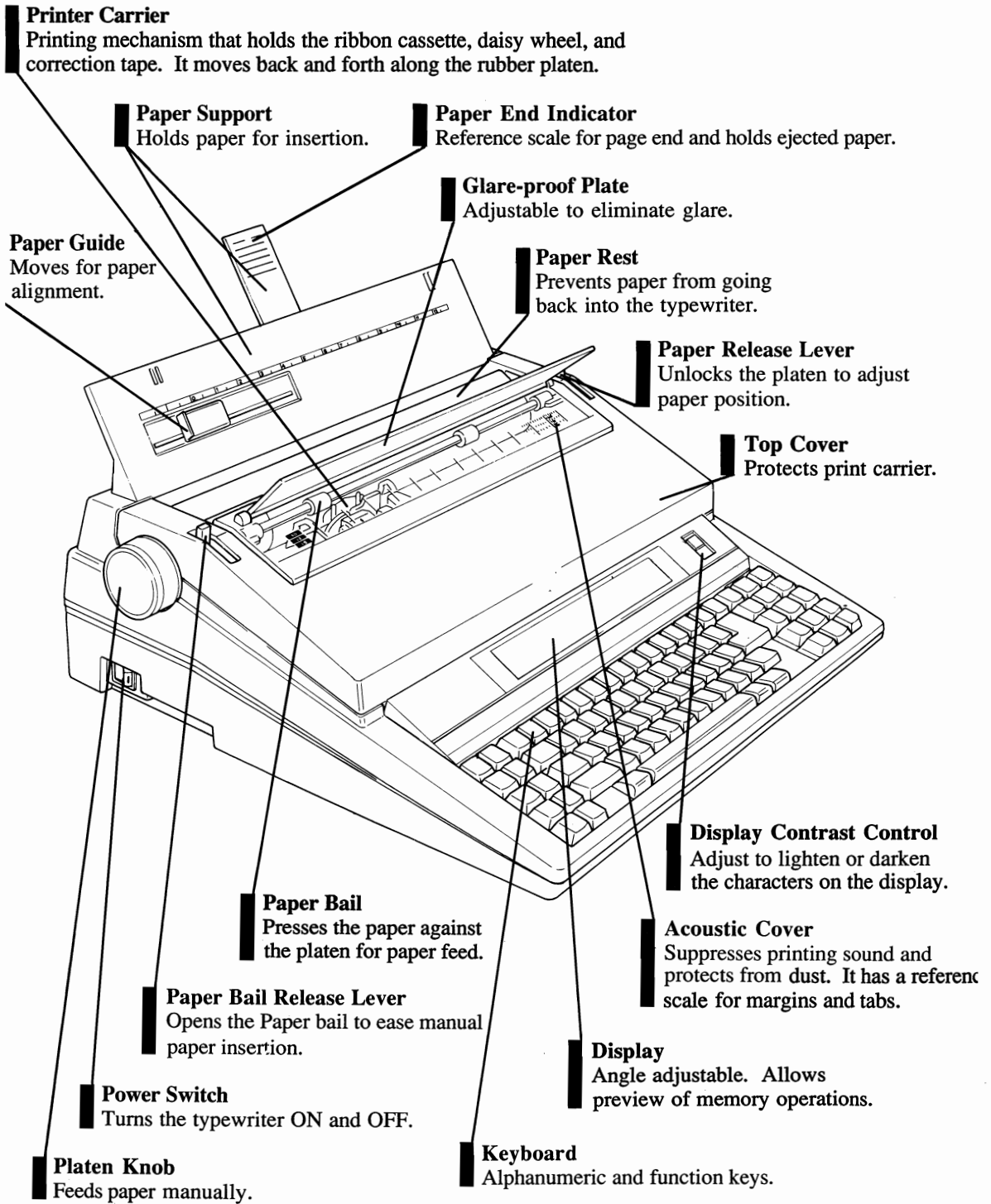

# Keyboard

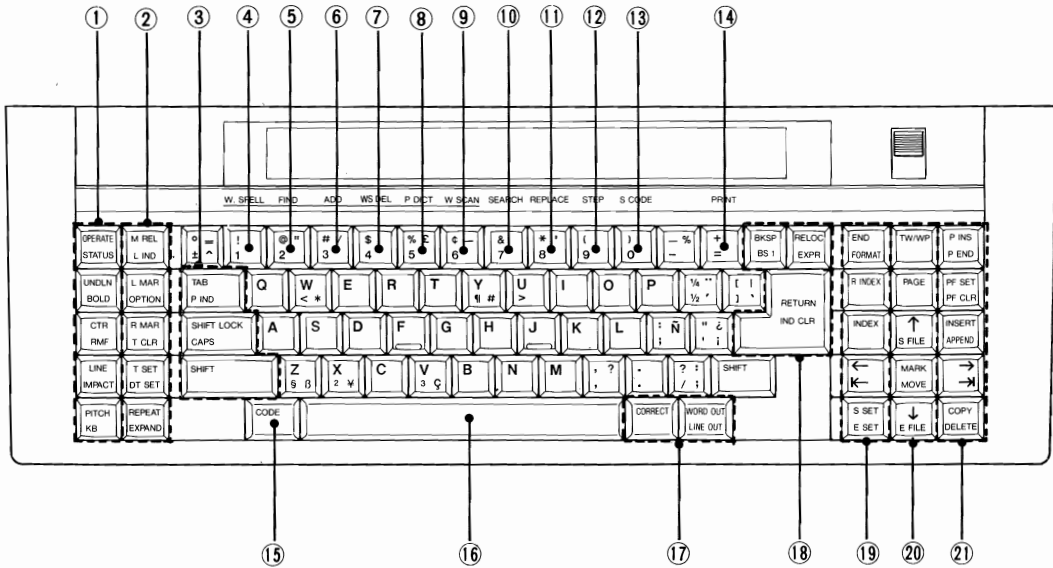

- ① Operate Key  
Status Key\*  
Auto Underline Key  
Bold Key\*  
Centering Key  
Right Margin Flush Key\*  
Line Spacing Selector Key  
Impact Selector Key\*  
Typing Pitch Selector Key  
Keyboard Selector Key\*

- ② Margin Release Key  
Line Indent Key\*  
Left Margin Key  
Option Key\*  
Right Margin Key  
Tab Clear Key\*  
Tab Set Key  
Decimal Tab Set Key\*  
Repeat Key  
Expand Key\*

- ③ Tab Key  
Paragraph Indent Key\*  
Shift Lock Key  
Caps Lock Key\*  
Shift Key

- ④ Word Spell Key\*

- ⑤ Find Key\*

- ⑥ Dictionary Add Key\*

- ⑦ Dictionary Delete Key\*

- ⑧ Dictionary Print Key\*

- ⑨ Word Scan Key\*

- ⑩ Search Key\*

- ⑪ Replace Key\*

- ⑫ Step Key\*

- ⑬ Stop Code Key\*

- ⑭ Print Key\*

- ⑮ Code Key

- ⑯ Spacebar

- ⑰ Correct Key  
Manual Correct Key\*  
Word Out Key  
Line Out Key\*

- ⑱ Backspace Key  
Backspace 1 Key\*  
Relocate Key  
Express Backspace Key\*  
Return Key  
Indent Clear Key\*

- ⑲ End Key  
Format Line Key\*  
Reverse Index Key  
Micro Reverse Index Key\*  
Index Key  
Micro Index Key\*  
Cursor Left Key  
Express Cursor Left Key\*  
Starting Line Set Key  
Ending Line Set Key\*

- ⑳ TW/WP Selector Key  
Page Key  
Format Page Key\*  
Cursor Up Key  
Start File Key\*  
Mark Key  
Move Key\*  
Cursor Down Key  
End File Key\*

- ㉑ Paper Insert Key  
Page End Set Key\*  
Page Format Set Key  
Page Format Clear Key\*  
Insert Key  
Append Key\*  
Cursor Right Key  
Express Cursor Right Key\*  
Copy Key  
Delete Key\*

\*: These keys are used with the CODE key.

The Option key is available only when the optional IF-20 is installed.

# SETTING UP YOUR TYPEWRITER

## Paper Support Assembly

The paper support is used to check and adjust the position of the paper.

Attach the paper support by inserting the tabs into the five holes provided on the top of the typewriter.

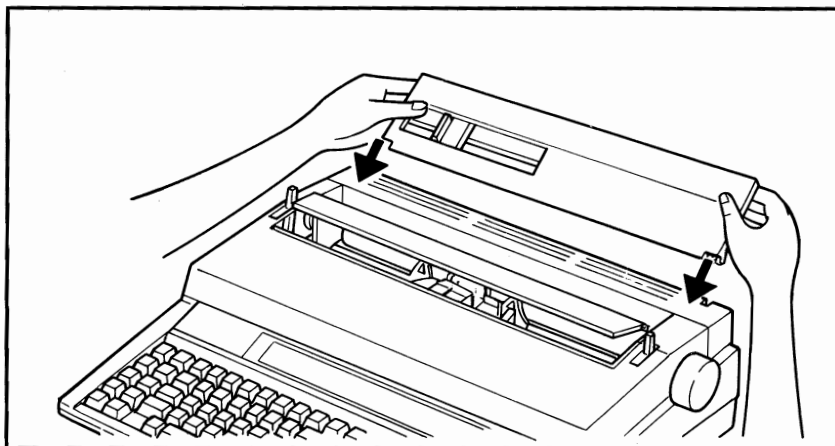

Now pull the paper end indicator behind the paper support body up so that it is in a vertical position.

The paper end indicator shows you how many lines are left on the paper, while the marks above the paper guide are used to identify the position of the paper.

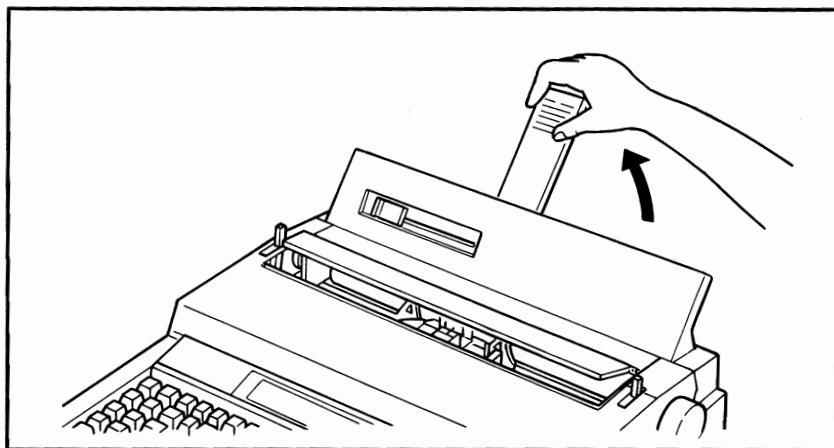

**Note:**

In the event that you need to move your typewriter, protect these parts from damage by returning the paper end indicator all the way to the right to its original position and detaching the paper support from the main unit.

## Acoustic Cover

The acoustic cover suppresses noise from the printing mechanism. It also prevents dust from getting inside the typewriter. Electronic typewriters really dislike dust, so when you type with your typewriter, please make sure that the acoustic cover is closed.

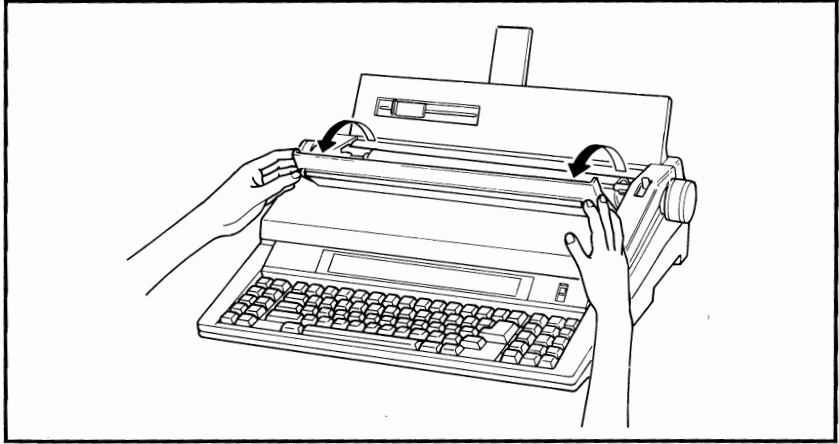

## Margin scale

The margin scale is printed on the acoustic cover and it indicates a three pitch scale (10, 12, and 15 characters/inch).

## Glare-proof plate

The glare-proof plate prevents the reflection of light to the acoustic cover, thus making it easier to see what you are typing.

# Top Cover

## Opening the top cover

In order to insert a new cassette daisy wheel, cassette ribbon or spool of correction tape, first place the top cover of the typewriter to the upright position. Do this by placing both hands on either end of the cover and lifting it upwards until it stands by itself.

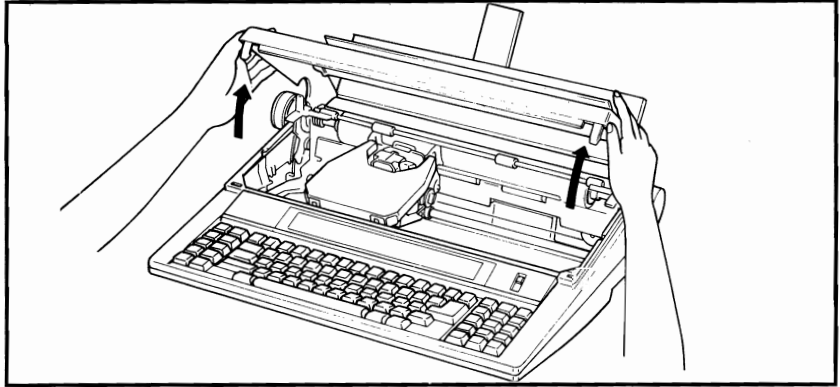

## Notes:

1. The keyboard locks up when the cover is raised, and typing is not possible until it is lowered again.
2. Opening the top cover has no effect on margin settings, tab settings or the correction memory, all of which are retained without change.
3. If the top cover is opened while your typewriter is in operation, if printing, it will immediately cease and the keyboard will lock. "COVER OPEN" will be indicated in the display. When the cover is closed again, the carrier will return to the start position, or, if there is data left in the buffer, it will resume printing.

## Closing the top cover

After inserting the cassette daisy wheel, cassette ribbon or spool of correction tape, close the top cover by replacing it to its original position. Ensure that it is firmly in place after closing.

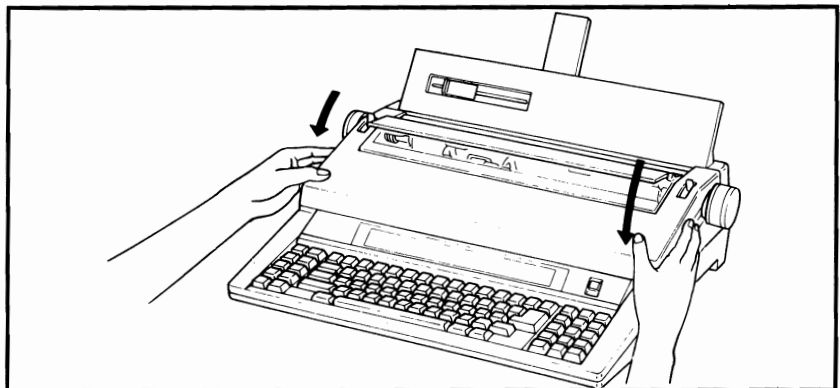

## Note:

If the top cover is closed with the unit switched ON, the carrier will automatically travel to the left edge, then return to the position.

# Power

## Installing the lithium battery

Install the lithium battery for the backup memory functions before you turn your typewriter ON. The lithium battery retains the backup memory for about 3 years.

To install the lithium battery, first open the top cover and remove the battery cover located at the left front side of the platen. To remove the battery cover, grasp the knob of the cover and lift it up.

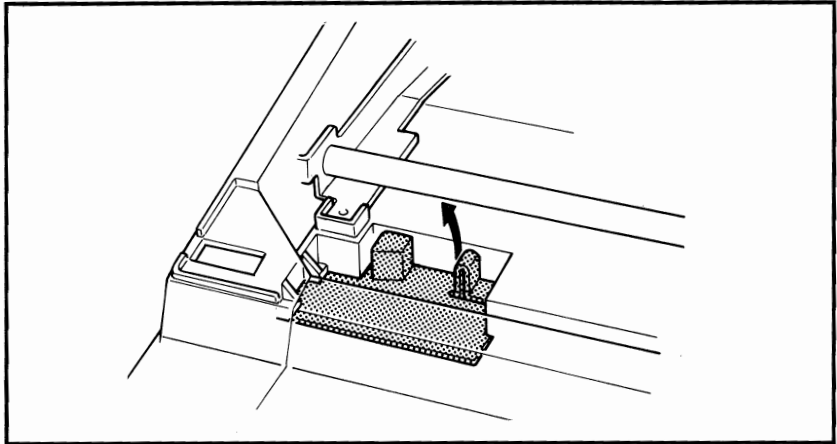

Slip the lithium battery into the slot with the battery facing to the bottom and slide it in as far to the left as it will go.

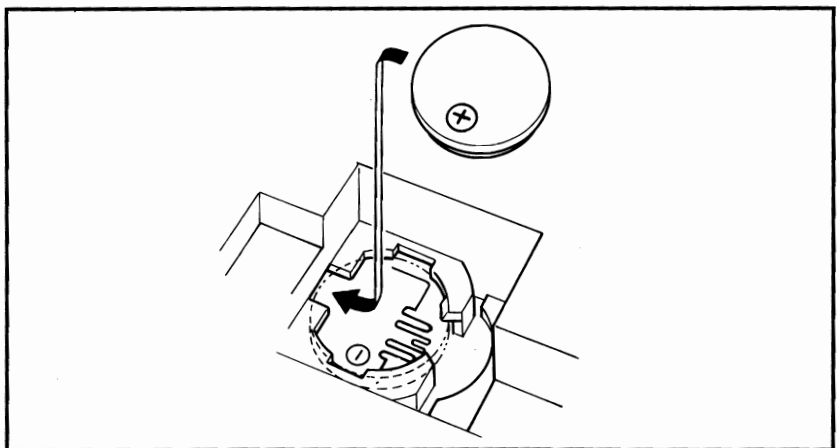

Replace the battery cover and then close the top cover.

### Notes:

1. When you replace the lithium battery, make sure that the machine is ON, otherwise the backup memory will be cleared.
2. Replace battery with Sony Energytec Inc., Part No. CR2032 only. Use of another battery may present a risk of fire or explosion.
3. Warning, battery may explode if mistreated. Do not recharge, disassemble or dispose of in fire.

## Power switch/Diagnostics

Your typewriter is now ready to be powered up. You'll find the power cord at the back of the typewriter. Simply unfold it and plug it in.

The Power Switch is located at the left rear side of the typewriter under the platen knob.

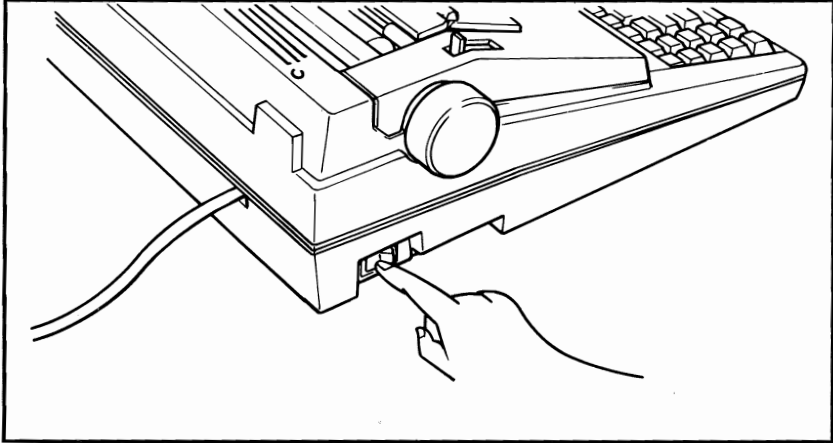

Place the Power Switch to the **ON** position. The daisy wheel rotates and stops. The carrier moves automatically to the far left end of the platen and then to the pre-set or the specified left margin.

Before the above occurs, however, your typewriter self diagnosis function will have checked its RAM and ROM. If the diagnosis detects anything abnormal in any of these, it will display one of the following:

**▲ RAM DOWN**

indicating a problem in the typewriter's Random Access Memory.

**▲ ROM DOWN**

indicating a problem in the typewriter's Read Only Memory.

**▲ CHECK PRINTER**

indicating a problem in the printer mechanism; the buzzer will also sound.

**▲ BATTERY LOW ! TURNING UNIT OFF WILL CAUSE MEMORY LOSS**

indicating the low voltage of the backup lithium battery.

**▲ BACKUP MEMORY CLEARED (BATTERY LOW)**

indicating that the backup memory is cleared caused by low voltage.



**Notes:**

1. Whenever you lift the top cover up, for example to change the cassette ribbon, the power to the typewriter will automatically go off. For this reason there is no danger in changing the cassette daisy wheel or cassette ribbon and correction tape even with the Power ON.
2. If any of the above didn't happen, take a look at the APPENDIXES, "TROUBLESHOOTING" at the end of this manual.
3. The top cover is not fully closed when "COVER OPEN" appears in the display.

## Cassette Daisy Wheel

Brother's slip-in, slip-out cassette daisy wheels are known the world over for their beautiful true letter quality type print. Here's a chance to discover it for yourself.

Your typewriter comes with a cassette daisy wheel already installed. You may, at some point, wish to change it for one with a different typeface, or to place a new one in. With the Brother typewriter, this is a very simple task.

### Removing the cassette daisy wheel

To remove the cassette daisy wheel, pull the motor lock lever toward you to release it, then grasp the 'ear' of the cassette daisy wheel between your thumb and forefinger and simply pull it out.

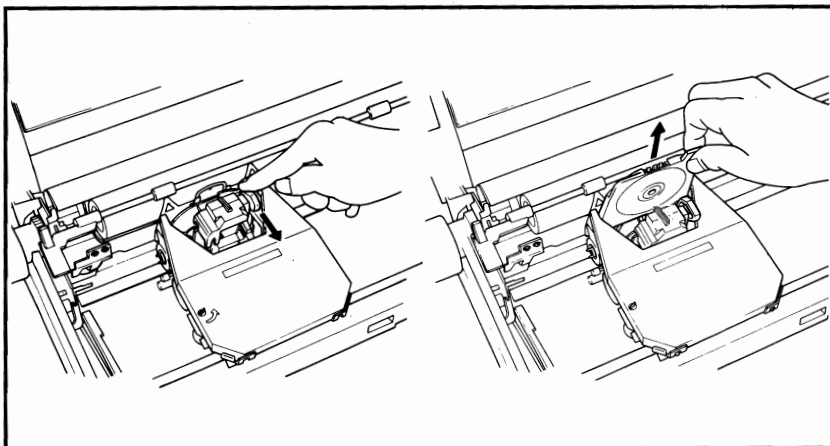
**Note:**

The cassette ribbon need not be removed in order to remove the cassette daisy wheel.

### **Inserting the new daisy cassette wheel**

Grasping the 'ear' of the new daisy cassette wheel between your thumb and forefinger, slip it into the cassette guide slot and slide it in as far as it will go.

Now press the motor lock lever back toward the platen until it clicks into place. Do not force the lever. If you have any difficulty, recheck the cassette daisy wheel to ensure that it is properly set and try again.

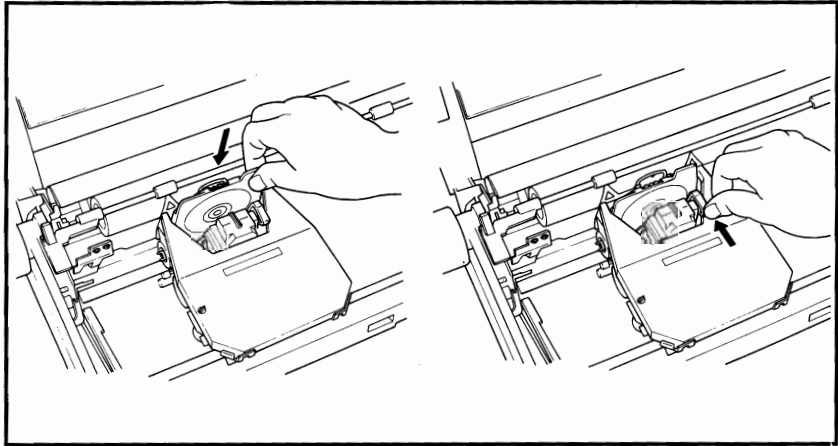

### **Notes:**

1. Be sure that the 'ear' of the cassette daisy wheel is to the right during insertion. Putting it in backwards can damage both the cassette daisy wheel and the motor mechanism.
2. If the cassette daisy wheel is not properly locked into position, characters will not be properly typed.
3. There is a wide selection of Brother cassette daisy wheels available.

## Cassette Ribbon

The wide range of Brother cassette ribbons available have two unique features in common: they are clean and trouble-free. Clean means that the ink goes where it is supposed to go--on the paper, and not on your hands!

### Removing the old cassette ribbon

First, use the **SPACEBAR** or **BKSP** key to move the carrier to the center of the platen. To remove the cassette ribbon, hold the cassette with both hands and raise the front end (near the platen). Then, when the ribbon is clear, simply lift the cassette up and out.

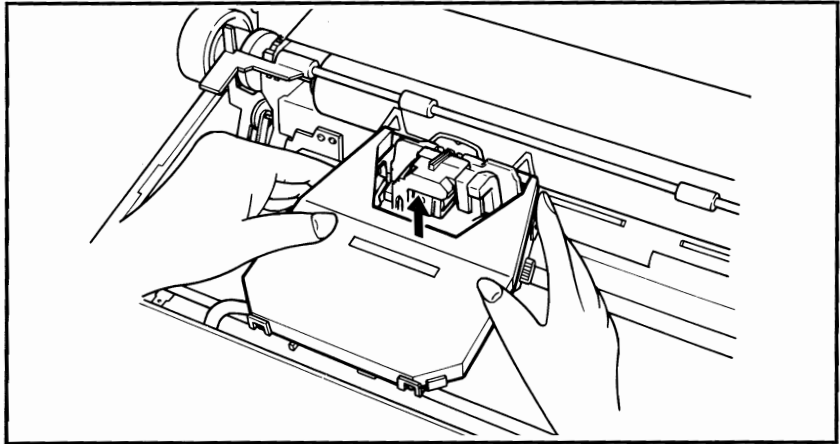

### Inserting the new cassette ribbon

Remove the stopper from the new cassette ribbon and turn the ribbon feed knob counterclockwise to tighten the ribbon.

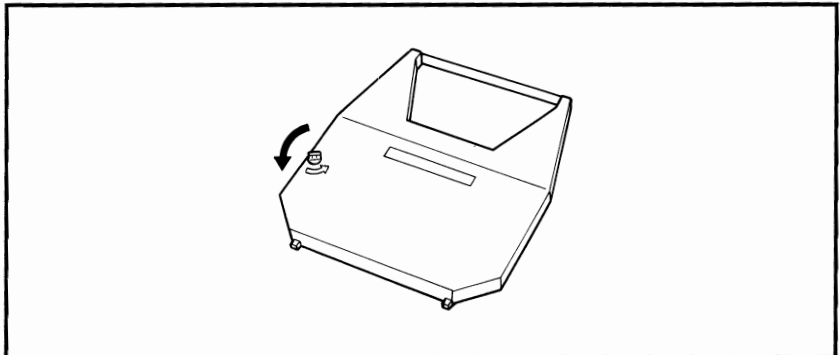

Now slip the back edge of the cassette (the part closest to you) into the cassette ribbon table and slide the ribbon between the ribbon guides.

With the ribbon set between the ribbon guides, press the cassette down until it locks into place. Turn the ribbon feed knob again slightly counterclockwise to tighten the ribbon.

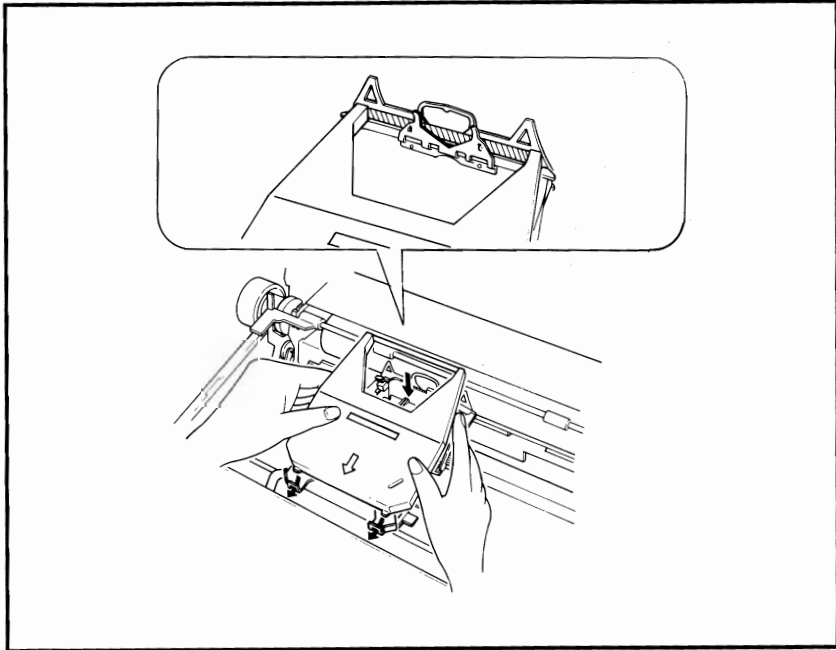

**Notes:**

1. A window is provided in the cassette to allow you to check on the remaining amount of ribbon.
2. Brother cassette ribbons are available in four different types:
  - Correctable film ribbon (standard with this model)
  - One-time film ribbon
  - Multi-strike film ribbon
  - Nylon ribbonThe correctable film ribbon is also available in red, blue, green and brown.

## Correction Tape

The correction tape guarantees a faultless document every time. What's more, the bottom of your typewriter will never be full of pieces of old correction paper and lumps of dried-up correction fluid!

**Removing the old correction tape**

If you need to replace the correction tape, first make sure that the carrier is in the center of the platen by using the **SPACEBAR** or **BKSP** key. Then remove the cassette ribbon.

Now just pull out the left and right spools of the old correction tape from the carrier.

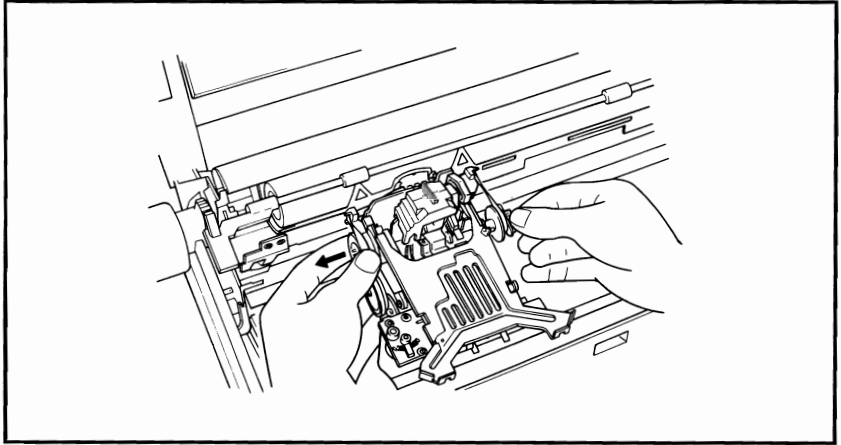

### Installing the new correction tape

First install the left spool, then thread the tape across the left and right guide rollers and install the right spool. Make sure that the active side of the correction tape is facing the platen.

Take up the slack by turning the right spool counterclockwise until the white portion of the tape comes to the right spool.

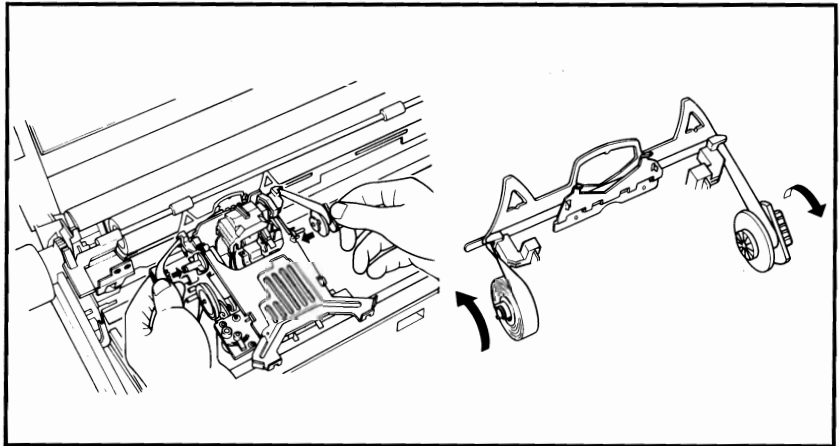

### Note:

Brother correction tapes are available in two types:

Lift-off correction tape (standard with this typewriter)

This is used together with the correctable film ribbon.

Cover-up correction tape

This is used together with the multi-strike film ribbon, one-time film ribbon or the nylon ribbon.

## Chapter 2

---

### THE DISPLAY

The display is an 80 column by 2 line liquid crystal display. It is divided into two fields. In the word processing mode, when in the CREATE-P mode the upper line of 80 columns and 76 columns of the second line, for a total of 156 columns become a single data zone. When in the CREATE-N and the EDIT modes all 160 columns of both lines become a single data zone. In the typewriter mode, only the 76 columns of the second line are operable. The second field is the counter zone at the lower right which consists of 3 columns, with a single blank column separating the two zones. The counter column indicates the number of characters which may be input between the present carrier position and the right margin.

The angle of the display unit is adjustable to the position for you to see it best. Holding both sides of the unit, just adjust to your best positions until you find the click position that suits you most.

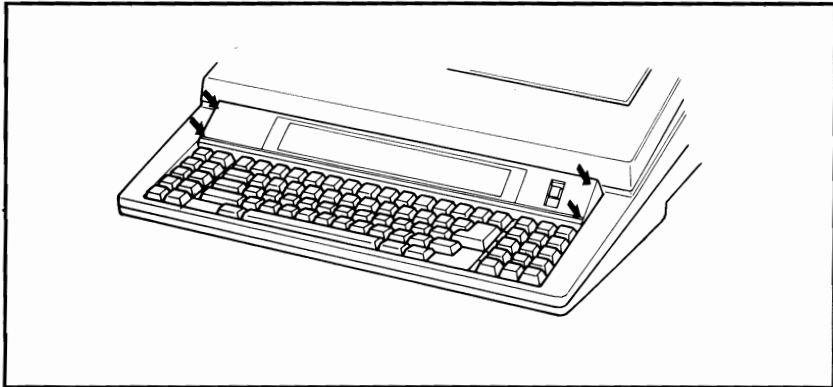

The display contrast control is located on the right side of the display. Pushing up the control will lighten the characters on the display, while pulling down the control will darken them.

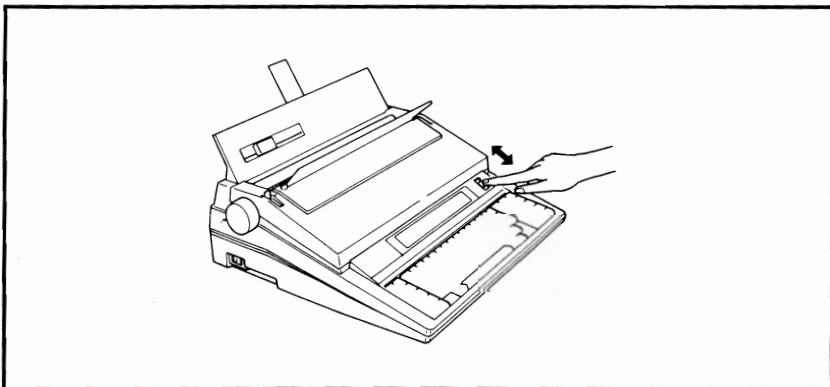

## Status Display

Pressing the **CODE + STATUS** keys will provide you with a display on the upper line of the current status, including typing functions (except in the typewriter mode, the status is always displayed on the upper line). Instead of having LEDs flashing each time you choose a function, the prompts corresponding to the activated function is displayed on the status line (upper line).

The following figure gives you the different prompts that can be displayed. The prompts below the display are alternatives to the prompt in the display. (The corresponding functions can never be selected together).

```

-FORMAT-
TW/WP PAGE LINE PITCH LINE   KB IMPACT
◀TW▶ 1 1 10 1   STD M EXPAND SHIFT BOLD CONT PIND AUTO DTAB W.SPELL
◀WP▶ 2 2 12 11/2 INTL H           CAPS      WORD      L/L   CTR
      3 3 15 2   SMBL L           JUST    RMF
      4 4
      5 5

```

TW	= typewriter	<u>CONT</u>	= continuous underlining
WP	= word processor	<u>WORD</u>	= word underlining
1~5	= page format	PIND	= paragraph indent
1~5	= line format	AUTO	= auto carrier return
10, 12, 15	= typing pitch	L/L	= line by line
1, 1 1/2, 2	= line spacing	JUST	= justification
STD, INTL, SMBL	= keyboard	DTAB	= decimal tab
L, M, H	= impact	CTR	= centering
SHIFT	= shift	RMF	= right margin flush
CAPS	= caps lock	W.SPELL	= spell checker
BOLD	= boldface		

## Special Display Code Table

Symbol code	Meaning	Symbol code	Meaning
	Space	<u>C</u>	Centering between margins
—	Permanent space	<u>T</u>	Centering between tabs
—	Permanent hyphen	<u>R</u>	Right margin flush
↑	Reverse index	↵	Return
↓	Index	↵	Paragraph indent clear
←	Permanent backspace	§	Stop code
Li	Line indent	...	Ghost hyphen
Pi	Paragraph indent	<u>F</u>	Line format
+	Tab	<u>B</u>	Block code
<u>D</u>	Decimal tab		

# Display Operations

## In typewriter mode

In the typewriter mode, the upper line of the data zone will show "TW" at the left side, as well as the selected page format, line format, pitch, line space, keyboard and impact settings. After these are displayed modes into which your typewriter has been placed during operation, such as BOLD, CTR, etc. When you set the decimal tab, centering, right margin flush, line by line and justification functions, the characters you type are first displayed. They will only be printed at the end of the line. The cursor will move only over the lower line of the mode, up to a point six columns before the counter separator.

## In word processor mode

### In the CREATE-P mode

In this mode, the lower line of the display shows characters as they are input up to a point six columns before the counter separator. When the carrier returns automatically or the RETURN or TAB keys are pressed the text is printed and the cursor returns to the left end.

### In the CREATE-N and EDIT modes

In these modes, the characters you type are displayed on the bottom line in the column before the cursor up to a point six columns before the counter separator. The cursor keys may be used to scroll the display to the left and right.



# Chapter 3

---

## BASIC TYPING FUNCTIONS

### Setting the Impact

Typing impact may be adjusted according to the quality and thickness of the paper you wish to use, or to the number of carbon copies you are making.

Select the desired impact force by holding down the **CODE** key and pressing the **IMPACT** key. Each time the **CODE + IMPACT** keys are pressed, impact force will change to the next setting in **L-M-H** order, and the selected setting will be indicated in the display.

**L** is for **LIGHT** impact force, **M** for **MEDIUM** and **H** for **HEAVY**. **L** should be used, for example, when a paper of light weight is being used, and **H** when making carbon copies.

**Note:**

Your typewriter is able to make up to 4 carbon copies in addition to the original document.

### Selecting the Keyboard

There are, believe it or not, three different keyboards contained in your electronic typewriter!

Select the desired keyboard by holding down the **CODE** key and pressing the **KB** key. Each time the **CODE + KB** keys are pressed, the keyboard selection will change to the next setting in **STD-INTL-SMBL** order, and the selected keyboard will be indicated in the display.

**STD**

This is the standard keyboard, and probably the one that you'll be using most of the time.

**INTL**

This Keyboard should be used when an optional "International" Cassette Daisy Wheel has been inserted. The characters indicated on the right portion of each key face are printed in this position.

**SMBL**

This Keyboard is for when you need to type mathematical formulas or numbers which require special symbols. There is also a Symbol Cassette Daisy Wheel optionally available

The symbol keyboard arrangement is shown below.



**Note:**

Be sure that the proper daisy wheel is used for the keyboard selected. For instance, when using **INTL**, an international cassette daisy wheel should be inserted, and the symbol cassette daisy wheel for **SMBL**.

**Dead keys**

The dead keys are the accent marks that may be placed over typed characters. The carrier does not move when a dead key is typed, and, when typed in the underline mode, the typed mark will not be underlined. (For American typewriter, accents can be typed only if you select the **INTL** or **SMBL** keyboard and use with an optional cassette daisy wheel.)

**Extra keys**

The extra characters that are printed in green on the bottom half of the **U~Z** keys are typed with holding down the **CODE** key and pressing the **U~Z** keys.

**Setting the Line Spacing**

This typewriter offers you three choices of line spacing: single line spacing, one and a half line spacing and double line spacing. Select the desired line spacing by pressing the **LINE** key. Each time the **LINE** key is pressed, the line spacing will change to the next setting in **1, 1-1/2, 2** order, and the selected line spacing will be indicated in the display.

- 1** Single line spacing places 1/6 inch of space between lines.
- 1-1/2** One and a half line spacing places 1/4 inch of space between lines.
- 2** Double line spacing places 1/3 inch of space between lines.

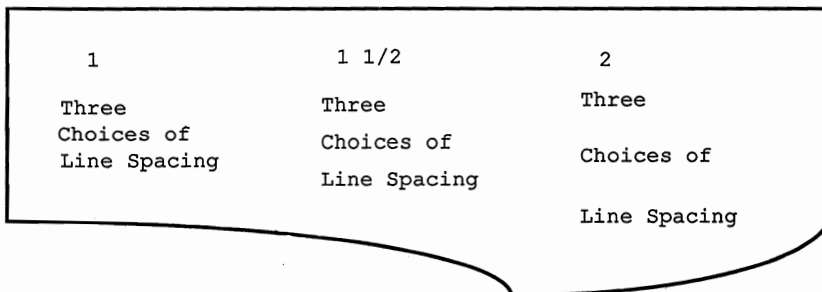

## Setting the Typing Pitch

The typewriter offers you three choices of pitch:  
**Pica** or **10** pitch (10 characters per inch)  
**Elite** or **12** pitch (12 characters per inch)  
**Micron** or **15** pitch (15 characters per inch)

Select the desired pitch by pressing the **PITCH** key. Each time the **PITCH** key is pressed, pitch will change to the next setting in **10, 12, 15** order and the selected pitch setting will be indicated in the display.

**10** pitch allows 117 characters to be typed per line.  
**12** pitch allows 140 characters to be typed per line.  
**15** pitch allows 175 characters to be typed per line.

10 Pitch gives a maximum of 117 characters per line.

12 Pitch gives a maximum of 140 characters per line.

15 Pitch gives a maximum of 175 characters per line.

## Code Key

The **CODE** key is used to access any function labeled in green, you must hold the **CODE** key while selecting the particular function.

## Auto Paper Insert

Inserting a sheet of paper into a typewriter has never been easier. Most types of smooth finish paper can be used with your typewriter. Rag content and other types of rough paper, however, are not recommended.

First, ensure that the power switch is **ON**, and that the **Paper Release Lever** is pressed to the rear.

Place the paper guide to the desired position, then, holding the sheet as straight as possible, insert the paper into the slot behind the paper rest with the left edge against the paper guide.

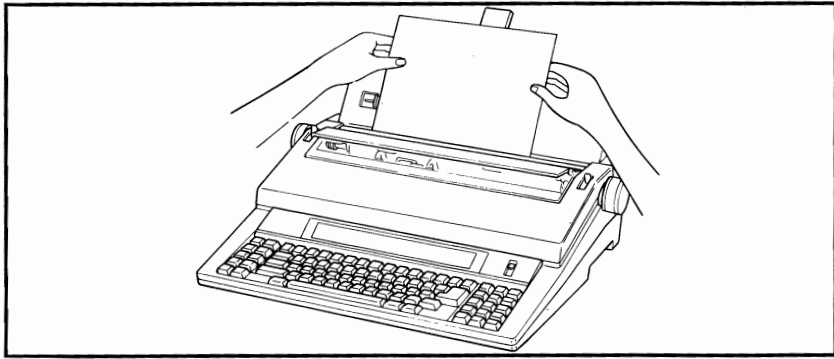

Now press the **P INS** key and watch. The carrier will first move to the left end of the platen and then back to the center of the margin scale, the paper bail will raise, and the platen rotates to feed the sheet of paper in automatically.

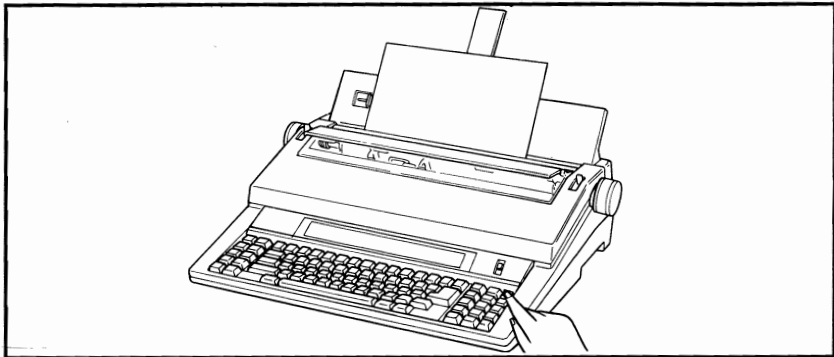

"PRESS RETURN" will appear on the display to move the carrier to the left margin. The paper will not be fed if you press the **RETURN** key at this time.

**Notes:**

1. When the auto paper insert function is used, the line buffer is automatically cleared.
2. For even more precise settings, you can also move the paper up or down 1/12" at a time with the **INDEX** and **R INDEX** keys. Press the **CODE + INDEX** keys and **CODE + R INDEX** keys for smaller increments of movement.
3. Pressing other than the **RETURN**, **TW/WP**, **INDEX**, **R INDEX**, **S SET**, **E SET**, or **P INS** key in the auto paper insert mode cause beep to sound.
4. If the paper is crooked or not properly aligned after automatic insertion, it may be adjusted manually. First turn the platen or use the **INDEX** key to feed more paper through, then pull the paper release lever forward. This will release the paper so that it may be moved manually and automatically lift the paper bail. Align the paper until it is straight, then return the paper release lever to its rearward position and turn the platen knob or use the **R INDEX** key to return the paper to the position from where you wish to begin typing. Press the **CODE + INDEX** keys and **CODE + R INDEX** keys for more delicate settings.

## Manual paper insert

You may need to use the manual method for unusual settings or for when you need to make a precise alignment in the middle of a document.

First insert the sheet of paper into the slit behind the paper rest while keeping the left edge of the paper in line with the paper guide. Set the paper release lever in its back position. Use both hands and try to keep the sheet as straight as possible.

Turn the platen knob until the lower edge of the paper is brought under the paper bail to the position desired. Raise the paper bail lever when you turn the platen knob and release the paper bail when the sheet of paper is set between the paper bail and the platen knob.

If the sheet is not straight, set the paper release lever in its forward position and fix the position of the sheet with both hands. Return the paper release lever to its original position and turn the platen knob until the sheet comes out to the desired position.

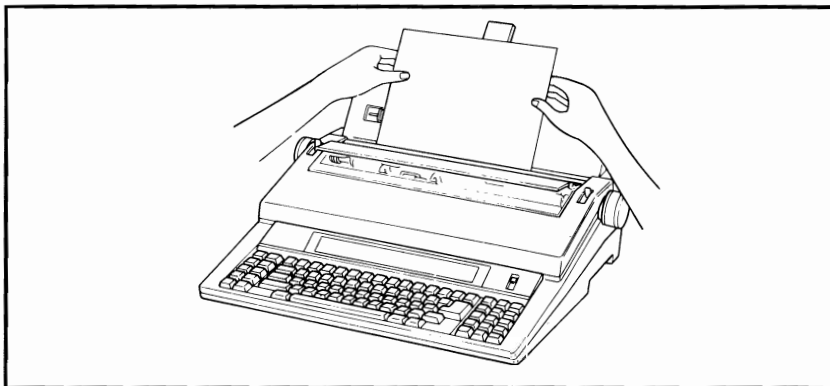

## Paper thickness control

The paper thickness control is located on the right side of the cassette ribbon table.

The lever is normally pushed all the way down in its standard position. Pulling the lever up increases the space between the carrier print head and the platen, thus enabling you to insert thicker paper and envelopes.

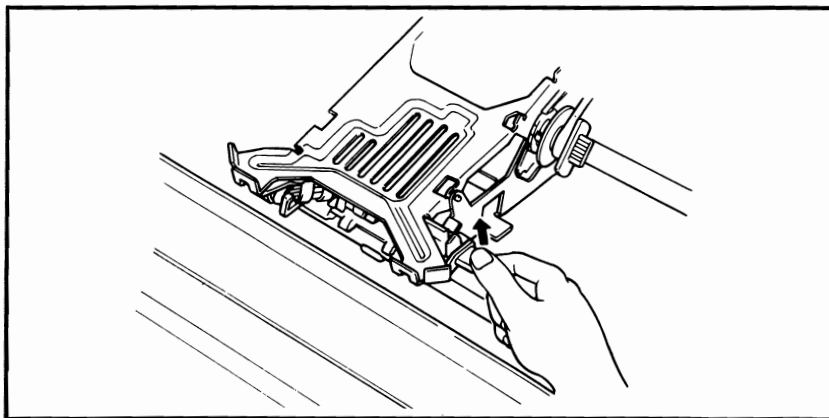

# Setting the Starting and Ending Lines

## Starting line

You may set the line at which you wish to begin typing and save it, so that the next time you use the auto paper insert function you won't have to adjust the paper at all.

Press the **P INS** key to place your typewriter into the paper insert mode and the "PRESS RETURN" prompt will appear. Before pressing the **RETURN** key, use the **INDEX**, **R INDEX**, **CODE + INDEX** and **CODE + R INDEX** keys to move the carrier to the position on the page, anywhere from one inch to six inches from the top of the page, at which you wish to begin typing. Now press the **S SET** key to set that line as the starting line to make it just a little easier to start typing next time.

### Notes:

1. Your typewriter is already preset with the starting line at one inch from the top of the page, so if that is where you want it, there is no need for modification.
2. Pressing other than the **INDEX**, **R INDEX**, **CODE + INDEX**, **CODE + R INDEX**, **S SET** or **CODE + E SET** key will clear the paper insert mode and the starting line will not be set.

## Ending line

The end line of the page may be set as well, anywhere within 16.5 inches from the top of the page. First use **P INS** key to insert a piece of paper and place your typewriter into the paper insert mode. The "PRESS RETURN" prompt will appear. Before pressing the **RETURN** key, then use the **INDEX**, **R INDEX**, **CODE + INDEX** and **CODE + R INDEX** keys to move the carrier to the line which is to be set as the ending line. Now hold down the **CODE** key press the **E SET** key to set it.

### Notes:

1. The ending line is controlled only in the typewriter mode.
2. Pressing the other than the **INDEX**, **R INDEX**, **CODE + INDEX**, **CODE + R INDEX**, **S SET** or **CODE + E SET** key will clear the paper insert mode and the ending line will not be set.
3. The pre-set of the ending line is set to 0 which means having no ending line setting.

## Page end

"PAGE END" appears on the display when the carrier passes the ending line. You should replace with a new paper by using the **INDEX**, **R INDEX**, **CODE + INDEX**, or **CODE + R INDEX** key, or manually to take out the paper.

### Note:

When the "PAGE END" prompt appears, pressing the **P INS**, **S SET**, **CODE + E SET** and **CORRECT** keys will clear the page end. If you press the **S SET** key, the current position is set as a starting line setting, while the **CODE + E SET** keys initialize the ending line setting, clearing the ending setting entirely. Page ending may be canceled temporarily by pressing the **CORRECT** key.

## Setting Margins

As you learned in the section on "POWER" in chapter 1, when the typewriter is switched ON, the carrier moves automatically to the far left and then 10 spaces to the right. This is the pre-set left margin in 10 pitch.

### Pre-set margins

The pre-set left margin will vary as will the right margin depending on the typing pitch as shown in the following table .

Pitch	Left margin	Right margin
10	10	75
12	12	90
15	15	112

### Left margin

Move the carrier to the place you wish the left margin to be, using the **SPACEBAR**, **BKSP**, **←**, **→** or **M REL** key.

Press the **L MAR** key. The left margin is now set. From now on, the carrier will return to this position each time the **RETURN** key is pressed.

### Right margin

Move the carrier to the place you wish the margin to be using the **SPACEBAR**, **BKSP**, **←**, **→** or **M REL** key.

Press the **R MAR** key. The right margin is now set.

#### Notes:

1. The minimum margin width is more than two inches between them and depends on the typing pitch, as shown in the following table.

Pitch	Min. Margin Width	Expand mode
10	20 characters	10 characters
12	24 characters	12 characters
15	30 characters	15 characters

2. If you are in the display mode, you cannot set the left and right margin.
3. Setting a new margin will clear the old margin setting.

### Margin release

After having set the margins, you may find it necessary on occasion to type outside them or release them to reset at a point beyond their current position. To move the carrier past a margin, press the **M REL** key.

To move to the left of the left margin, use the **BKSP** or **←** key to the left margin, press the **M REL** key and continue to press the **BKSP** or **←** key to where you wish to begin typing.

To move past the right margin, hold the **SPACEBAR** or **→** key until the carrier reaches the right margin. Press the **M REL** key, then continue spacing using the **SPACEBAR** or **→** key.

# Setting Tabs

## Normal tabs

Tabs are set by moving the carrier by the **SPACEBAR**, **BKSP**, **←** or **→** key to the position at which a tab is desired and pressing the **T SET** key.

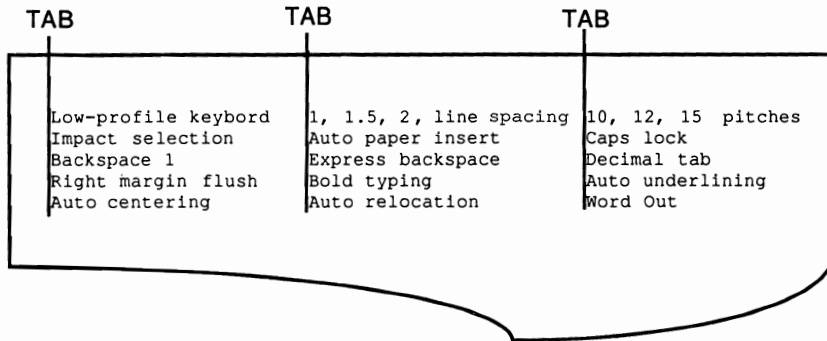

### Notes:

1. When a tab is set in the same position as a decimal tab, the decimal tab in that position will be changed to a normal tab when the **T SET** key is pressed.
2. Tab positions are set according to the absolute position of the carrier (in units of 1/60") based on the left edge, so they do not change even when the margins or pitch have been changed.
3. The maximum of 24 tab stops, including the decimal tabs, can be set on your typewriter.
4. Tabs cannot be set in the display mode.

## Decimal tabs

This function allows you to type columns of numbers aligned at decimal points.

Decimal tabs are set by moving the carrier to the position at which a decimal tab is desired and holding the **CODE** key and pressing the **DT SET** key. The Decimal tab mode will be indicated on the display as "D TAB" on the status line and the message "DECIMAL TAB" will appear after pressing the **TAB** key.

Now type the number and it will start printing after a decimal point is typed. Continue to type the numbers following the decimal point without interruption.



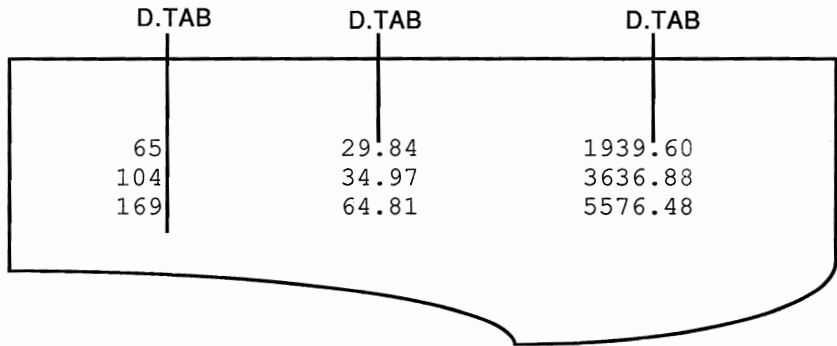

**Notes:**

1. Decimal tabs may be set in the paragraph indent position while in the paragraph indent mode.
2. When a decimal tab is set in the same position as a normal tab, the normal tab in that position will be changed to a decimal tab when the **CODE + DT SET** keys are pressed.
3. Decimal tab positions are set according to the absolute position of the carrier (in units of 1/60") based on the left edge, so they do not change even when the margins or pitch have been changed.
4. A maximum of 24 decimal tab stops, including the tabs, can be set on your typewriter.
5. Decimal tabs cannot be set in the display mode.

**Tab clear**

To clear a normal or decimal tab, move the carrier by the **TAB** key to the position of that tab and hold down the **CODE** key and press the **T CLR** key.

**Notes:**

1. In the paragraph indent mode, when the paragraph indent tab is cleared, the tab itself will be disabled but this does not release your typewriter from the Paragraph indent mode.
2. When no data is input while in the decimal tab mode, the decimal tabs may be cleared, but your typewriter will remain in the decimal tab mode.

**All tab clear**

Pressing the **REPEAT** key after pressing the **CODE + T CLR** keys will clear all normal and decimal tabs, regardless of the position of the carrier.

## Typing Upper Case Characters

To type upper case characters, press either the right or left **SHIFT** keys and "SHIFT" will be indicated while the **SHIFT** key is pressed. Releasing this key automatically returns the keyboard to the lower case mode.

For continuous upper case typing, press the **SHIFT LOCK** key. The "SHIFT" will be indicating on the status line that the **SHIFT LOCK** key has been enabled and the keyboard is suspended in the upper case mode. The shift lock mode will be indicated in the display as "SHIFT". To return to lower case typing, press either the right or left **SHIFT** key.

```
BROTHER ELECTRONIC TYPEWRITER  
Congratulations on becoming the proud owner of a  
Brother Typewriter.
```

If you want to type upper case letters with the numerical keys in lower case, hold down the **CODE** key and press the **CAPS** key. The "CAPS" will be indicated on the status line that you are in the caps lock mode. Upper case symbols and punctuation marks may also be typed while in the caps lock mode merely by pressing the **SHIFT** key and the key for the character you wish to type. The caps lock mode will be indicated in the display as "CAPS". To return the keyboard to the normal mode, press the **CODE + CAPS** keys once again.

```
MODEL #ML432XFY  ITEM X1942  
MODEL #ML569PQR  ITEM X1943
```

### Note:

The "CAPS" will not be indicated by pressing the **CODE + CAPS** keys while in the shift lock mode. It will be indicated only after the shift lock mode is canceled.

## Backspacing

Your typewriter has four different backspace functions to move back across a line.

### Simple backspace

Use the **BKSP** key to move the carrier to the left one space at a time. Hold the **BKSP** key down to move the carrier continuously to the left.

## Express backspace

Holding down the **CODE** key and pressing the **EXPR** key will bring the carrier immediately back to the left margin. If you are in the paragraph indent mode, pressing the **CODE + EXPR** keys once brings the carrier back to the indent position, and pressing it a second time moves the carrier to the left margin.

## Backspace 1

Holding down the **CODE** key and pressing the **BS1** key will move the carrier to the left by 1/60".

As the distance backspaced remains constant at 1/60" regardless of the typing pitch being used, backspacing in this case varies by pitch as shown in the table.

Pitch	Spacing
10	1/6 of a character pitch
12	1/5 of a character pitch
15	1/4 of a character pitch

This function is useful in numerous different ways, including positioning a character or word when the paper has been re-inserted into the typewriter. It is also used for typing a character or word into a limited space on a document or form.

### Note:

The Backspace 1 function may not be used when centering, in the right margin flush mode or using a decimal tab, line by line or justification mode.

## Permanent backspace

The permanent backspace is used to overstrike the previous character for only in the display mode. Just press the key for the character to be overstruck, then hold down the **CODE** key and press the **BKSP** key and then the key for character over which a new one is to be superimposed.

## Repeat Function

To repeat a character and some other functions (tab, return, index/reverse index, space, permanent space, backspace, auto correction, cursor movements, delete, all tab clear and all page format clear), press the **REPEAT** key after pressing the character or function key.

## Self repeat

The following keys repeats itself by holding down.  
**SPACEBAR, BKSP, Permanent space (CODE + SPACEBAR),  
CORRECT, ←, →, DELETE, INDEX and R INDEX.**

# Chapter 4

---

## ADVANCED TYPING FUNCTIONS

### Bold

Place your typewriter in the bold typing mode by holding down the **CODE** key and pressing the **BOLD** key. The bold mode will be indicated on the status line as "BOLD".

All characters typed after pressing the **CODE + BOLD** keys will be printed in bold, and in the display mode, they will blink. Pressing the **CODE + BOLD** keys once again will clear the bold mode and return your typewriter to the normal mode.

This letter was typed to show you just some of the many outstanding feats this electronic typewriter can perform.

In fact, you have seen some of these features already in this letter; **Bold**, Underline, and **E x p a n d** typing can be easily done with this typewriter.

### Auto Underline

There are two types of underline mode. The continuous underline mode underlines all characters and spaces, while the word underline mode underlines only the words and leaves spaces blank.

Pressing the **UNDLN** key once places your typewriter into the continuous underline mode, which is indicated on the status line as "CONT." Pressing it one more time places it in the word underline mode, indicated as "WORD", and pressing it once again releases it from the underline mode.

Therefore, to release your typewriter from the underline mode while in the continuous underline mode requires that the **UNDLN** key be pressed twice, while releasing it from the word underline mode requires that it be pressed only once.

## Expand

The expand function doubles the amount of space between characters typed in any pitch. To place your typewriter in the expand mode, hold down the **CODE** key and press the **EXPAND** key. The expand mode will be indicated on the status line as "EXPAND".

Your typewriter is released from the expand mode by holding down the **CODE** key and pressing the **EXPAND** key once again.

## Carrier Return

When this key is pressed, the carrier will return to the left margin and advance the paper by the number of lines set with the **LINE** key (1, 1-1/2, 2).

To return the carrier, just press the **RETURN** key.

## Auto carrier return

Placing your typewriter into the automatic carrier return mode will save you having to press the **RETURN** key every time you reach the end of a line. This function works by automatically returning the carrier to the left margin whenever the **SPACEBAR** or **HYPHEN** is pressed with the carrier in the hot zone.

To put your typewriter in the automatic carrier return mode, just press the **OPERATE** key while your typewriter is in the normal mode. The automatic carrier return mode will be indicated on the status line as "AUTO".

In the typewriter mode, pressing the **OPERATE** key switches modes in Normal-Auto-L/L-Just sequence as shown below. All but the normal mode will be indicated on the status line.

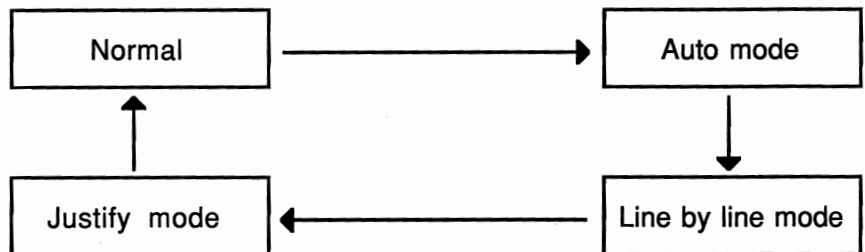

## Hot Zone

The Hot Zone is an area that begins 6 spaces (regardless of pitch) before the right margin and extends to the margin. A beep will sound as the carrier enters the hot zone to inform you of the fact. Once the beep has sounded to warn you, you have the six spaces of the hot zone to end your line. If you continue to type, the carrier will stop at the right margin and the keyboard, except for the carrier return, will lock. This is to keep you from typing past the margin, unless, of course, you use the margin release function to continue.

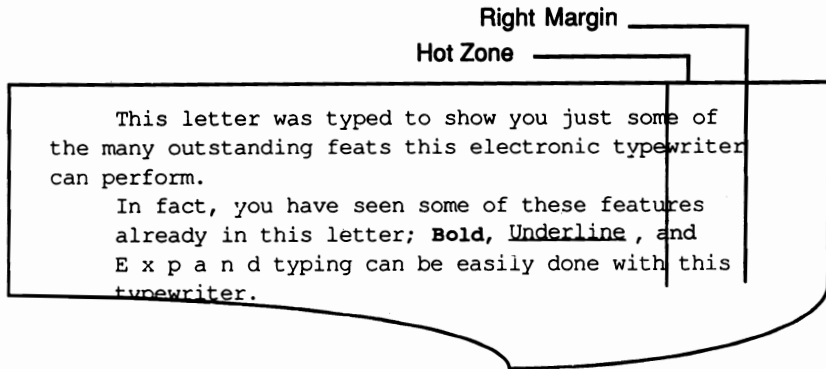

## Permanent Spaces and Hyphens

If you wish, in the automatic carrier return mode, to type a space or hyphen in the hot zone without the carrier returning automatically, you may use the permanent space and hyphen functions.

To type a permanent space or hyphen, hold down the **CODE** key and press either the **SPACEBAR** or the **HYPHEN** key, simultaneously.

# Centering

## Centering between margins

Placing the carrier at the left margin and pressing the **CTR** key will move the carrier immediately to a position halfway between the left and right margins and place your typewriter in the centering mode as indicating "CTR" on the status line. The cursor will be indicating the left edge and the counter will indicate the number of characters that may be input.

When you type now, the characters will not be printed to the page and will be indicated from the left edge of the display, but the carrier will move, from its position at the center of the paper, one-half space to the left for every character and space you type (except for the first character and dead characters).

When you have finished typing to be centered, press the **RETURN** or **TAB** key to print the line. The "PRINTING" prompt will appear on the display while printing the line by pressing the **TAB** key. Your typewriter will now leave the centering mode. If the **RETURN** key was pressed, the carrier will then line feed and return to the left margin. If the **TAB** key was pressed, the carrier will remain on the same line, moving to the nearest tab to the right, or, if there is no tab, to the right margin.

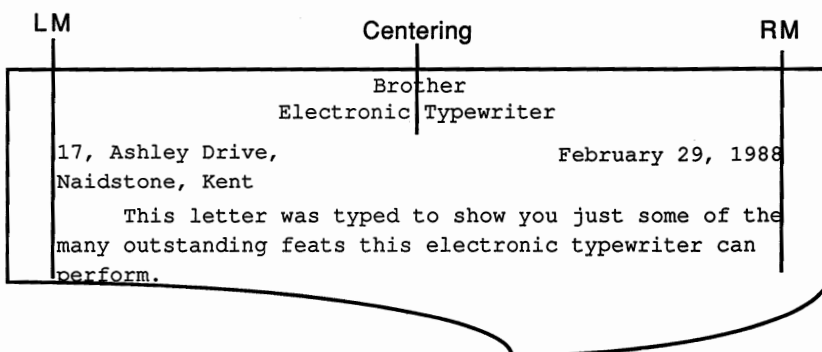

### Notes:

1. To leave the centering mode before any data has been input, press the **CTR** key. This will release your typewriter from the centering mode. The prompt which will disappear from the status line, and return the carrier to the left margin.
2. To leave the centering mode after the data has been input, delete the words on the display by using the **CORRECT**, **BKSP**, **WORD OUT**, **CODE + LINE OUT** and **CODE + DELETE** keys, then press the **CTR** key.
3. You can make corrections in the display mode before pressing the **RETURN** or **TAB** key.
4. If the entered characters overrun the space between margins, the beep sounds.

## Centering between tabs

Placing the carrier at the tab you want and pressing the **CTR** key will move the carrier immediately to a position halfway between the chosen tab and the next tab (which may be the right margin) and place your typewriter in the centering mode as indicating "CTR" on the status line. The cursor will be indicating the left edge and the counter will indicate the number of characters that may be input .

When you type now, the characters will not be printed to the page and will be indicated from the left edge of the display, but the carrier will move, from its position at the center of the tabs, one-half space to the left for every character and space you type (except for the first character and dead characters).

When you have finished typing the line, press the **RETURN** key or the **TAB** key to print the line. The "PRINTING" prompt will appear on the display while printing the line by pressing the **TAB** key. Your typewriter will now leave the centering mode. If the **RETURN** key was pressed, the carrier will then line feed and return to the left margin. If the **TAB** key was pressed, the carrier will remain on the same line, moving to the nearest tab to the right, or, if there is no tab, to the right margin.

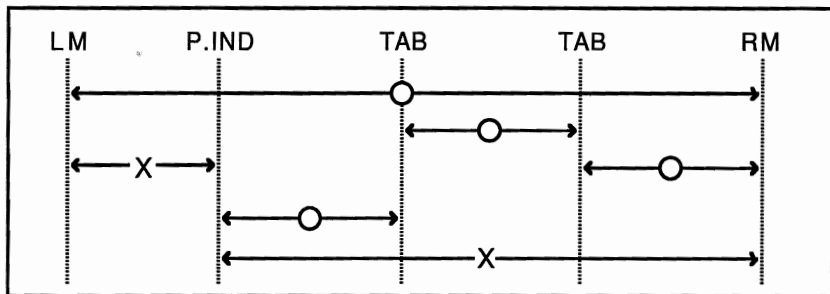

### Notes:

1. To leave the centering mode before any data has been input, press the **CTR** key. This will release your typewriter from the centering mode. The prompt will disappear from the status line, and return the carrier to the first tab stop.
2. To leave the centering mode after the data has been input, delete the words on the display by using the **CORRECT**, **BKSP**, **WORD OUT**, **CODE + LINE OUT** and **CODE + DELETE** keys, then press the **CTR** key.
3. You can make corrections in the display mode before pressing the **RETURN** or **TAB** key.
4. If the entered characters overrun the space between tabs, the beep sounds.
5. You can not center between the left margin and the first tab.
6. In the paragraph indent mode, a text will not be centered between the temporary left margin and the right margin, but with the next tab stop.



## Right Margin Flush

Right margin flush automatically aligns text flush with the right margin. Holding down the **CODE** key and pressing the **RMF** key while the carrier is anywhere to the left of the right margin will cause the carrier to move to the right margin. The carrier will then move to the left one space for every character you type (two in the expanded mode and except for dead characters).

The right margin flush mode will appear on the status line as "RMF" and the counter will indicate the number of characters that may be input. The cursor will be indicating the left edge of the display.

When you have finished typing the line, press the **RETURN** key or the **TAB** key to print the line. The "PRINTING" prompt will appear on the display while printing. Your typewriter will now leave the right margin flush mode. If the **RETURN** key was pressed, the carrier will then line feed and return to the left margin. If the **TAB** key was pressed, the carrier will move to the right margin.

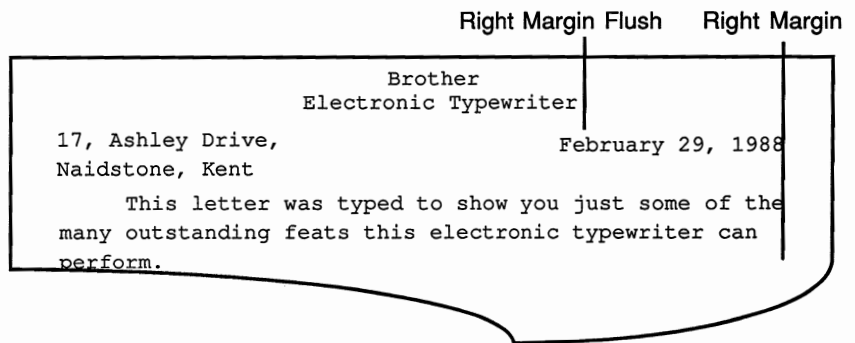

### Notes:

1. To leave the right margin flush mode before any data has been input, press the **CODE + RMF** keys again. Your typewriter will be released from the right margin flush mode, "RMF" will disappear from the status line, and the carrier will relocate to its previous position.
2. To leave the right margin flush mode after the data has been input, delete the words on the display by using the **CORRECT**, **BKSP**, **WORD OUT**, **CODE + LINE OUT** and **CODE + DELETE** keys, then press the **CODE + RMF** keys.
3. You can make corrections in the display mode before pressing the **RETURN** or **TAB** key.
4. If the entered characters overrun the space between margins, the beep sounds.

## Justification

The justification mode allows you to print a text aligned with both left and right margins. Just press the **OPERATE** key until "JUST" indicates on the status line.

The input characters are not directly printed. They are displayed first, and the carrier and cursor move simultaneously for each character entered. Pressing the **SPACEBAR** or **HYPHEN** in the hot zone prints justified text. Entering the character after the display symbol (...) of the ghost hyphen appearing justifies a text, when the **HYPHEN** is pressed in the hot zone. Spaces will be added between words to fill out the line. The carrier is automatically returned.

To leave the justification mode, just press the **OPERATE** key again. Your typewriter will be released from the justification mode and "JUST" will disappear from the status line.

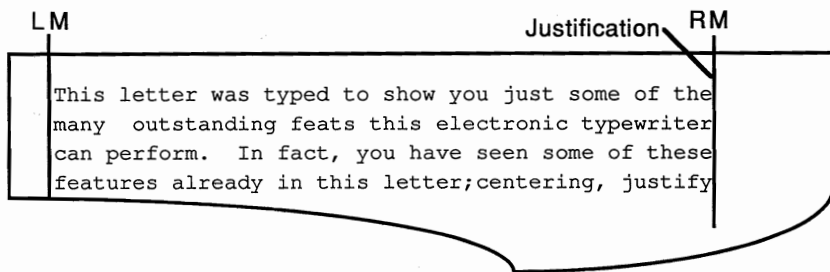

### Notes:

1. If the **RETURN** key is pressed, the line will be printed aligned with the left margin only.
2. If the right margin is reached when the last character is entered, the carrier will not return automatically by pressing the **SPACEBAR**, but the **RETURN** key.
3. If the right margin is reached while typing a word, press the **BKSP** or **CORRECT** key to return to a point where a hyphen or space can be inserted in the hot zone.

# Indentation

## Line indent

The line indent mode allows you to indent the first line of your paragraph in one step. Just hold down the **CODE** key and press the **L IND** key at the beginning of your paragraph.

The "LINE INDENT" prompt will appear on the display and, the carrier will automatically move over five spaces and wait for you to begin typing. Each time you press the **CODE + L IND** keys, the carrier will advance five spaces.

## Paragraph indent

The paragraph indent mode will set a temporary left margin at your tab position. First set a tab at the position you wish the paragraph to begin. With the carrier to the left of the tab stop, hold down the **CODE** key and press the **P IND** key.

The "PARAGRAPH INDENT" prompt will appear on the display and the carrier will move over to the first tab and wait. The message disappears and the "P IND" will appear on the status line when the the first character is entered. Thereafter, whenever the carrier return is pressed, the carrier will return to that first tab position rather than the left margin and the "PARAGRAPH INDENT" will appear on the display.

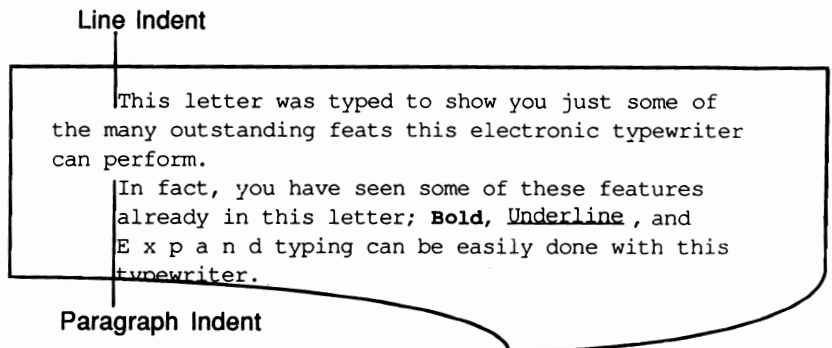

### Note:

If you want to type from the left margin or to the left of the paragraph indent point in the paragraph indent mode, simply use the **BKSP** or **CODE + EXPR** key.

## Indent clear

The **CODE + IND CLR** keys is used when you wish to clear the paragraph indent function. The carrier returns to the left margin when you press the **RETURN** key.

# Framing

The framing mode allows you to type both horizontal and vertical lines, provided that you use an International or Symbol cassette daisy wheel (optionally available). Please make sure to select the correct keyboard.

Press the **CODE + T CLR** keys and then hold down the **REPEAT** key to remove all tab stops. Decide where you want the vertical line and set new tabs in these positions.

Now hold down the **CODE** key and press the **S** key to enter the framing mode. The carrier will move to the left margin and the "HOW MANY ROWS ? TYPE NUMBER AND PRESS RETURN: 0" will appear on the display.

You merely type the number of rows you wish and then press the **RETURN** key. You can only enter two numbers (between 0 and 99). If you enter a third number, the first number will be deleted, the second will be shifted to the left, and the third is displayed on the right. Your typewriter starts printing the horizontal lines first.

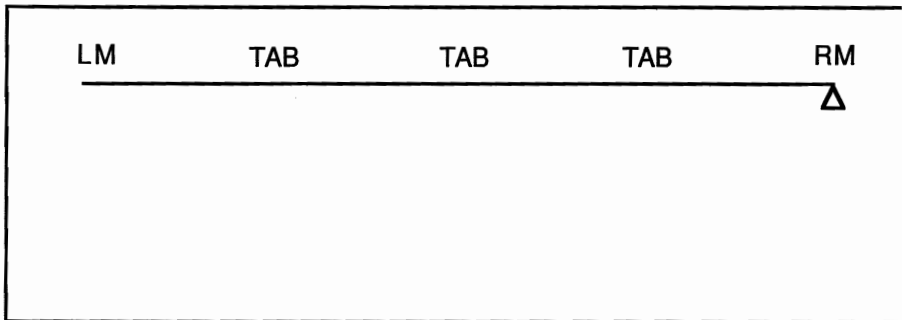

The carrier will return automatically with the specified line space. This will repeat as the numbers you type for the rows and repeat once at the end. If you type 3 for the rows, a fourth horizontal line will be printed as shown.

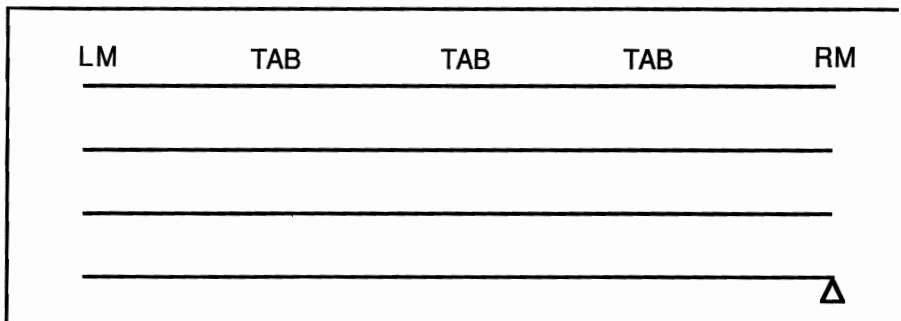

After the horizontal lines are printed, the carrier will go back to the left end of the first line and start printing the vertical lines. The vertical lines will be printed as shown.

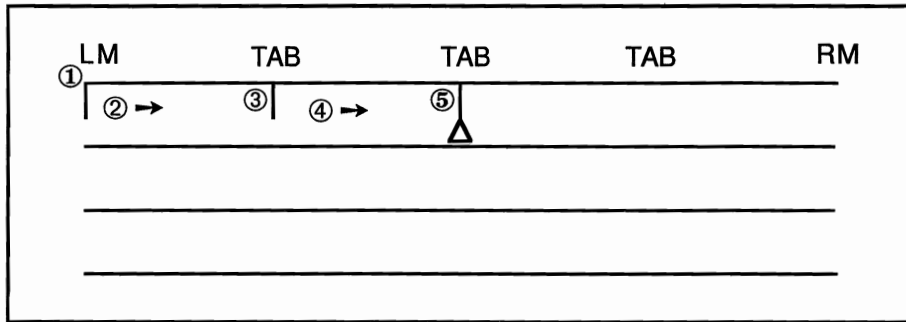

The carrier movement (reverse index and tab movement) will follow the sequence of the numbers in the figure to complete the vertical lines.

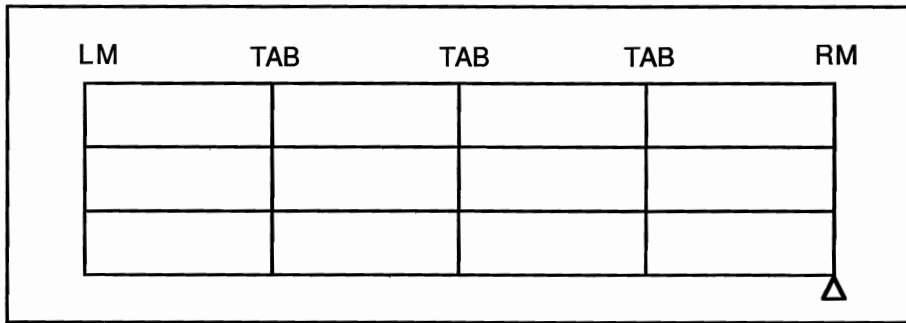

The "COMPLETED" prompt will appear on the display when the framing mode is completed and your typewriter will return to the normal mode.

**Notes:**

1. The line spacing, when the **RETURN** key is pressed after typing the number of rows, will be selected for the framing mode.
2. Pressing the **END** key will cancel printing and the framing mode.
3. If you press the **CODE + S** keys while the "STD" is selected for the keyboard, the "INCORRECT KEYBOARD" prompt will appear on the display.

# Corrections

## Automatic correction

Automatic correction may be performed on the current line.

In order to use the automatic correction, first use the **SPACEBAR**, **BKSP**, **←** or **→** key to move to the character you wish to correct.

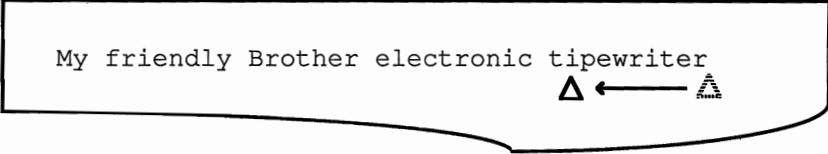

My friendly Brother electronic typewriter  
△ ← → △

When the carrier is directly over the character to be corrected, press the **CORRECT** key. The character will be removed, and the carrier will remain in that position.

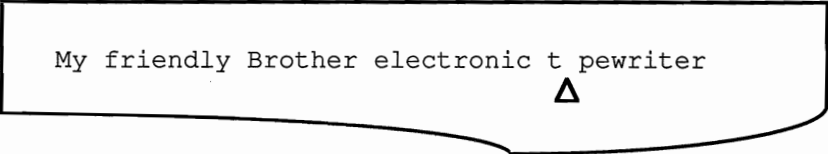

My friendly Brother electronic t pewriter  
△

You may type the correct character, or move on, as necessary.

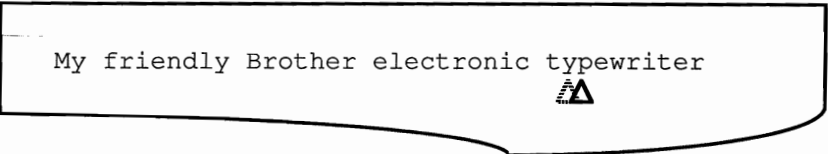

My friendly Brother electronic typewriter  
△

You may go back to where you were before beginning corrections by pressing the **RELOC** key.

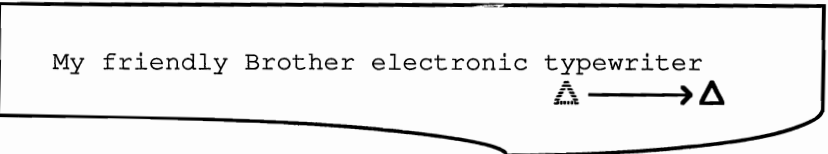

My friendly Brother electronic typewriter  
△ → △

### Notes:

1. If held down, the **CORRECT** key will repeat the correction function.
2. The automatic correction function works on bold, superscript, subscript, superimposed, dead, and underlined characters as well.

## Manual correction

Manual corrections may be performed any place on the page.

First move the carrier to the position to be corrected using the **R INDEX**, **↑**, **SPACEBAR**, **BKSP**, **←** or **→** key as necessary.

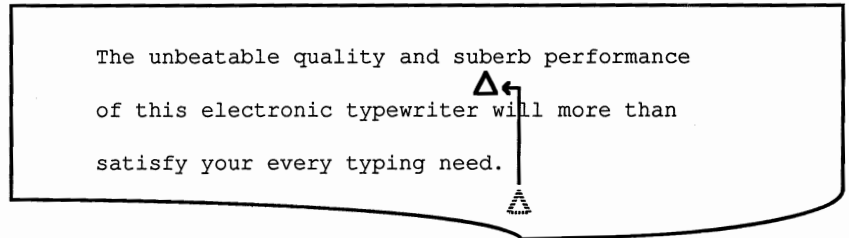

Hold down the **CODE** key and press the **CORRECT** key, and the "MANUAL CORRECTION" prompt will appear on the display. Then press the character to be corrected.

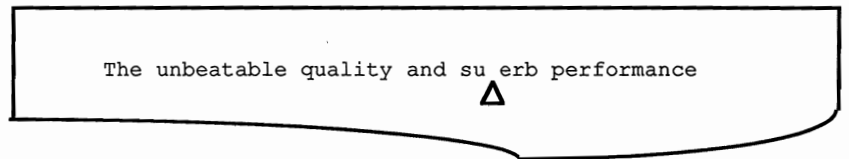

That character will be removed and the carrier will remain in that position for you to type in a new character, or move on, as necessary.

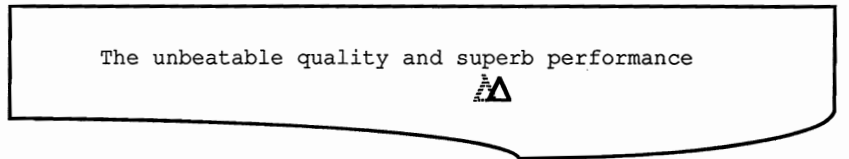

Use the **INDEX**, **↓**, **SPACEBAR** or **BKSP** key to go back to the point where you left off typing.

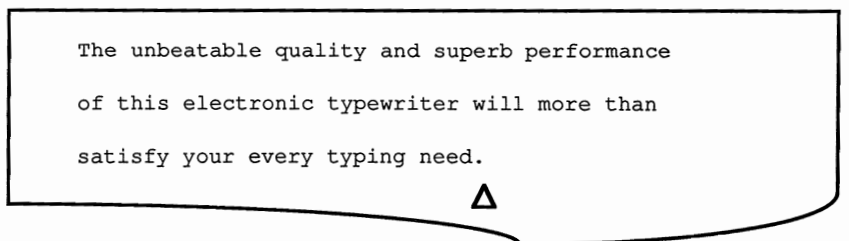

### Notes:

1. Manual corrections work only for the single character being corrected.
2. If the **SPACEBAR** is pressed after the **CODE** + **CORRECT** keys have been pressed, the correction function is cleared and the carrier will move to the right one space.
3. Correcting the underlined or bold character, the manual correction works only when the underline mode or the bold mode is on.

## Correcting justified and centered text

When you print text justified to both margins, the spaces between the words may not correspond any longer to the chosen pitch. Centered text, similarly, is justified to a centrally located point on the page rather than to one margin or the other. The **BS1** key may be used to line the carrier up with justified and centered text which requires correction.

## Word out

The word out function will remove a whole or partial word from the current line.

First use the **SPACEBAR**, **BKSP**, **←** or **→** key to move to the last character or to the space immediately to the right of the word to be removed.

Only Brother electronic typewriters guarantee the  
perfect document everytime!



Press the **WORD OUT** key. The word will be removed up to the previous space.

Only Brother electronic typewriters guarantee the  
perfect document

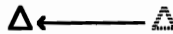

Now you can type the correct word(s).

Only Brother electronic typewriters guarantee the  
perfect document the whole year round!

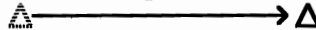

### Notes:

1. If the carrier is positioned in the middle of a word, only the letters from that position to the beginning of the word will be erased.
2. This function erases superimposed, super/subscripts, bold, and underlining if they are part of the word.
3. To interrupt the word out function, press the **CORRECT** key.



## Backspace 1 and word out

This advanced function allows you to add or delete the character with the help of the **BS1** key and still retain the document balance.

### Insertions

First use the **SPACEBAR**, **BKSP**, **←** or **→** key to move to the last character or to the space immediately to the right of the word to be removed.

This electronic typewriter is real typng happiness!



Press the **WORD OUT** key to delete the whole word. The carrier will remain at the position of the last character removed.

This electronic typewriter is real happiness!

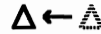

To squeeze in an extra character, hold down the **CODE** key and press the **BS1** key a few times. Each time the **CODE** + **BS1** keys are pressed, the carrier moves 1/60 of an inch to the left. Type in the correct word.

This electronic typewriter is real happiness!



To go back to where you were before beginning the correction, press the **RELOC** key.

This electronic typewriter is real typing happiness!

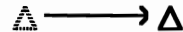

## Deletions

First use the **SPACEBAR, BKSP, ←** or **→** key to move to the last character or to the space immediately to the right of the word to be removed.

This electronic typewriter is reall typing happiness!

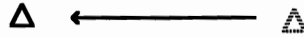

Press the **WORD OUT** key to delete the whole word. The carrier will remain at the position of the last character removed.

This electronic typewriter is          typing happiness!



Press the **SPACEBAR** to move the carrier to the second character of the deleted word. Now hold down the **CODE** key and press the **BS1** key a few times. Each time the **CODE + BS1** keys are pressed, the carrier moves 1/60 of an inch to the left. Type in the correct word.

This electronic typewriter is          typing happiness!



To go back to where you were before beginning the correction, press the **RELOC** key.

This electronic typewriter is real typing happiness!

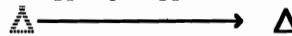

## Line out

This function allows you to delete the entire line or a portion of the current line.

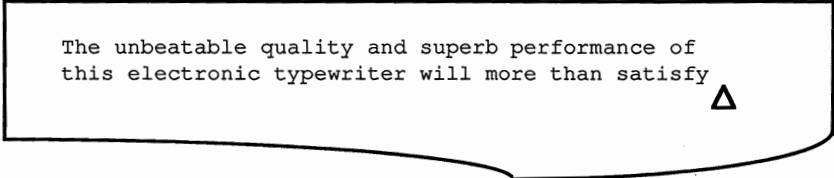

First move the carrier to the position of the last character of the line or to the space immediately to the right of the last character to be deleted. Press the **SPACEBAR**, **BKSP**, **←** or **→** keys as necessary.

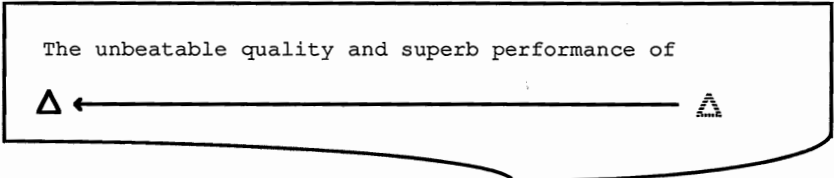

The unbeatable quality and superb performance of  
this electronic typewriter will more than satisfy 

Hold down the **CODE** key and press the **LINE OUT** key. All of the characters will be erased and the carrier will stop at the beginning of the line and await your input.



The unbeatable quality and superb performance of  
 ←————— 

### Notes:

1. If the carrier is positioned in the middle of a word, correction will start from that position to the beginning of the line.
2. This function erases superimposed, super/subscripts, bold, and underlining if they are part of the word.
3. To interrupt the line out function, press the **CORRECT** key.

## Relocation

The **RELOC** key allows you to move rapidly through typed text by moving the carrier. If, for instance, you backspaced through the line to make a correction, you could use the **RELOC** key to move the cursor back through the line to the end.

## Index/Reverse Index

The **R INDEX** and **INDEX** keys are used to place your typewriter in the superscript and subscript modes. In the direct type mode, the platen will rotate slightly up or down to allow typing of super and subscript characters 1/12" higher or lower than the base line (see micro indexing below). In the display mode, the platen will not move, but an up or down arrow symbol will appear to indicate the super or subscript modes.

To put your typewriter in the superscript mode, press the **R INDEX** key, and to put it in the subscript mode, press the **INDEX** key. Type the character that you wish in super or subscript.

With the Reverse Index key or Index key, you can type  
 $2^3$  or  $H_2O$ .

Now press the opposite key to release your typewriter from the super or subscript modes.

**Note:**

If your typewriter is in the automatic underline mode, superscript and subscript characters will be typed with an underline.

## Micro index and micro reverse index

This function allows you to set more delicate settings in superscript and subscript. Pressing the **CODE + R INDEX** or **CODE + INDEX** keys will place your typewriter in the super or subscript mode, as with the **R INDEX** and **INDEX** keys, but the characters typed in this mode will only be 1/48" above or below the base line.

**Note:**

The micro index and micro reverse index mode will clear the line correction memory.

# Chapter 5

---

## MEMORY FUNCTIONS

Your typewriter is equipped with a backup memory function to store text, line/format settings and a user dictionary. This memory will retain data even when the typewriter is not ON or in use, but only while it is powered, i.e., while plugged in or with batteries installed.

Your typewriter has a maximum memory capacity of 52K, but individual files are limited to a maximum of 15K in length. When the memory of your typewriter has reached its full capacity, the following message will appear:

▲ MEMORY FULL

When the memory capacity for the file you are currently editing has reached capacity, the following message will appear:

▲ FILE MEMORY OVER

## Backup Battery

The backup lithium battery has been installed to retain text, line and format settings for about 3 years. When the power switch is turned on, the backup battery will check its voltage, and if the voltage is low, the following message will appear:

▲ BATTERY LOW ! TURNING UNIT OFF WILL CAUSE MEMORY LOSS

The backup function retains the following settings (the content in parentheses shows the initial setting):

Margins	(10, 75)	Start line	(1 inch)
Tab	(None)	End line	(0)
Pitch	(10)	Operate	(Normal)
Line	(1)	Overwrite/Insert	(Overwrite)
Impact	(M)	Framing line	(0)
Keyboard	(STD)		

**Notes:**

1. The following messages are given priority if the specified problem is detected by the self diagnosis function:  
"RAM DOWN", "ROM DOWN", "CHECK PRINTER"
2. If you clear the Backup Ram, while the voltage of the battery is low, the following message will appear:

▲BACKUP MEMORY CLEARED (BATTERY LOW)

3. Change the battery once every 3 years. The new battery should be replaced while the typewriter is ON, otherwise the memory will be cleared.

## Line Format Memory

This function allows you to create up to five typing formats and retain them for future use by specifying format values and storing them to memory.

The format values that may be written to memory include the following (the numbers in parenthesis indicate the values to which these are set at shipment until modified by the user):

- Left margin (10)
- Right margin (75)
- Tab and decimal tab positions (none)
- Pitch (10)
- Line spacing (1)
- Starting line (1 inch)
- Ending line (none)

### Storing a line format in memory

To store a line format to memory, hold the **CODE** key then press the **FORMAT** key to select a format number. Each time the **CODE** + **FORMAT** keys are pressed, the format number changes on the status line.

Set the desired format by setting the margins, tabs, pitch, line spacing, etc. These settings are now in effect for this format number.

**Notes:**

1. A line format may not be stored while in the display mode.
2. The storage operation may be performed regardless of the position of the carrier.

### Calling a line format from memory

Pressing the **CODE** + **FORMAT** keys will change the current format setting to the next setting in numerical order. The carrier will move to the new left margin and the format and counter values on the display will change to reflect the new values.

-FORMAT-  
TW/WP PAGE LINE PITCH LINE KB IMPACT

◀TW▶ 1 2 10 1 STD M ◀

# Page Format Memory

This function allows you to create up to five page formats and retain them for future use by specifying format values and storing them to memory.

The format values that may be written to memory include the maximum of 30 settings in one page for the carrier positions.

## Storing a page format in memory

A page format is stored to memory by pressing the **CODE + PAGE** keys to call out the number of the page format you desire to change. The **P INS** key may then be used to insert a piece of paper into your typewriter. Now move the carrier to the positions on the page you wish to insert into the page format memory, pressing the **PF SET** key at each up to 30 settings. That value will be stored to memory. Up to five page formats may be stored.

## Calling a page format from memory

Holding down the **CODE** key and pressing the **PAGE** key will change the current format setting to the next setting in numerical order. The new page format number will appear in the display.

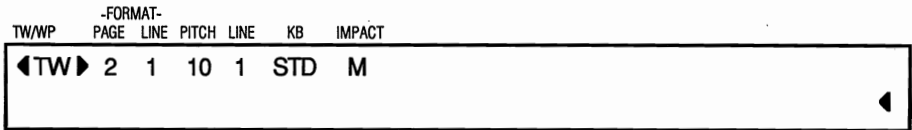

## Utilizing a called out page format

Once a page format has been called from memory by pressing the **CODE + PAGE** keys, use the **P INS** key to insert a piece of paper. The **PAGE** key may now be used to move the carrier from one set position on the page to the next automatically. If you press the **PAGE** key, while the carrier is positioned as shown, the carrier will move to the PF 3. Type the appropriate information at each of the stop position.

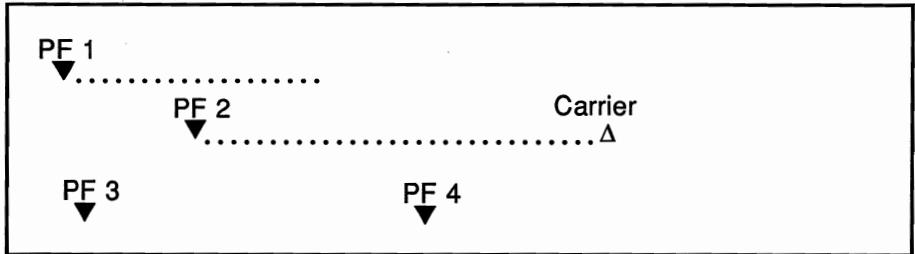

## Page format clear

Hold down the **CODE** key and press the **PAGE** key to call out the page format number you wish to change. Now press the **PAGE** key to place the carrier over the page position you wish to clear, then press the **CODE + PF CLR** keys to clear it.

## Page format all clear

Hold down the **CODE** key and press the **PAGE** key to call out the page format number you wish to clear, then press the **CODE + PF CLR** keys and then the **REPEAT** key to clear all the format values from that page format. This may be accomplished regardless of the position of the carrier.

## Clearing the Backup Memory

To clear the backup memory, hold down the **CODE + SHIFT** keys and then press the **DELETE** key simultaneously. The following display appears:

▲BACKUP MEMORY CLEARED

This will clear the entire memory of all data previously saved and place your typewriter in the typewriter mode.



# Chapter 6

---

## DISPLAY MODE

The display mode stands halfway between the typewriter and word processor modes. In this mode, characters are displayed before they are printed, allowing you to view and correct your text on the display before it is typed.

The display mode is automatically selected when using the decimal tab, centering, right margin flush and justification functions. Each of these functions require that the line be completely typed before printing (so that the carrier may be positioned prior to printing, which requires that the length of the line and its start position on the page be determined before typing).

You can, however, take advantage of the conveniences of this mode even though not utilizing any of the above functions by selecting L/L (line by line) processing (covered below).

Pressing the **OPERATE** key switches modes in Normal-Auto-L/L-Just sequence. All but the normal modes will be indicated on the display.

### Notes:

1. Formatting functions, i.e., the setting of tabs and margins, etc., may not be entered in this mode; you must switch back temporarily to the printing mode.
2. The **M REL** and **CODE + BS1** keys may not be used in the display mode.

## Line by Line Processing

Press the **OPERATE** key until "L/L" appears on the status line to place your typewriter in the line by line mode. The cursor will position itself to the left.

Type your text. It will be shown on the display, and the carrier will move for each character entered. Characters are not printed right away, so that entries can be edited before printing.

Pressing the **TAB**, **RETURN**, **CODE + L IND/P IND** or **PAGE** keys will print the text and perform the function of the key pressed. As your typewriter is still in the auto mode, a space entered into the hot zone will also cause the line to be printed and the carrier to return; if a hyphen is entered, the next character entered will be printed on the left end of the display after the line has been typed.

The line by line mode may be canceled and your typewriter placed in the justification mode by pressing the **OPERATE** key once again.

# Cursor and Display Functions

## Cursor left and right

The cursor moves to the right for each character entered, but the left and right cursor keys allow you to move the cursor back along the text to make corrections or edit as necessary.

Moving the cursor to the left with the ← key will move the cursor to the left one space. Holding down the ← key will continue to move the cursor to the left. The line scrolls to the right when the cursor reaches the left end after the display is filled with text.

```
◀TW▶ 1 1 10 1 STD M L/L
The left and right cursor keys allow you to move the cursor back along t ▶
```

Press the → key to move the cursor to the right one space. Hold down the → key to continue moving to the right. The line scrolls to the left when the cursor reaches to the right end after the display is filled with text.

```
◀TW▶ 1 1 10 1 STD M L/L
left and right cursor keys allow you to move the cursor back along the te ▶
```

## Express cursor left and right

Although the cursor left and right keys may be used to scroll the display, when there is a large amount of text, the **CODE + ←** keys or **CODE + EXPR** keys, and **CODE + →** keys or **RELOC** key may be used to scroll the text quickly to the beginning or to the end.

# Correction in Display Mode

## Overwrite

The overwrite mode allows you to write new text or a new character over previously entered text. The overwrite cursor is a blinking underline.

## Insertion

Pressing the **INSERT** key allows the insertion of characters into a line of text. The cursor (an alternate display of character and ) will begin to blink, and typed characters will be input in the column before the cursor. Pressing the **INSERT** key once again will return your typewriter to the overwrite mode.

◀TW▶ 1 1 10 1 STD M L/L
The cursor will begin to blink, and typed character will be input. ◀

◀TW▶ 1 1 10 1 STD M L/L
The cursor will begin to blink, and typed character will be input. ◀

## Deletion

Pressing the **CODE + DELETE** keys delete the character at the cursor position and scrolls the following text to the left one column. Holding down these keys will repeat deleting. This function allows you to delete superimposed, super/subscript, bold, and underlined characters.

◀TW▶ 1 1 10 1 STD M L/L
the cu_r_s_o_r position and scrolls the following text to the left one column. ◀

◀TW▶ 1 1 10 1 STD M L/L
the cu_r_s_o_r position and scrolls the following text to the left one column. ◀

You also may use the **CORRECT** or **BKSP** key to delete the character in front of the cursor. Holding down the key will repeat deleting.

## Word out

The cursor must be placed on the character immediately to the right of the word or part of a word to be corrected. When the **WORD OUT** key is pressed, all of the characters to the left of the cursor up to the previous space will disappear, and the text to the right will scroll to the left along with the cursor to eliminate the space previously occupied by the word or characters removed.

## Line out

Move the cursor to the space or character immediately to the right of the text to be deleted and press the **CODE + LINE OUT** keys. The cursor and any remaining text from the cursor position to the right will move to the left margin.

## Functions Requiring a Special Display

The fraction, underlining, bold, superscript/subscript, superimposed, accentuated characters and expand characters have special appearances on the display.

### Fractional numbers

The fractional numbers are displayed as shown below:

ex.) 1/2

1
2

### Underlined characters

Underlined characters are actually underlined. The cursor position is also underlined in the overwrite mode, but it is easy to tell where the cursor is because the alternate display makes the cursor position blink.

### Bold characters

Bold characters are blinking. However, it is impossible to confuse the cursor position with characters that are both bold and underline; the cursor location and the character blink in different ways.

### Superscripts and subscripts

Superscript (reverse index) characters are represented by an arrow pointing upward, while an arrow pointing downward stands for subscript (index) characters. First type the first character and press the **R INDEX** or **INDEX** key. Then type the character for superscript or subscript, the super/subscript symbol will be displayed before the super/subscript character.

The super/subscript symbol will be displayed before that character as shown below:

ex.)  $e=mc^2$

$e=mc\uparrow 2$
------------------

ex.)  $H_2O$

$H\downarrow 2O$
------------------

### Note:

The super/subscript symbol accompanies on the following character: if this character is deleted, the mark is deleted with it. It is impossible to add a symbol alone; it will always be followed by a character or a symbol.

### Superimposed characters

Superimposed characters are created with the permanent backspace mode which backspace does not erase the character to the left of the cursor. Enter the first character and press the **CODE + BKSP** keys. The cursor moves one space to the left without erasing the character and then enter the second character. The character will be displayed to the right of the first character.

ex.) Ø

O←/

### Accented characters

Accented characters are displayed as shown below:

ex.) Ö

" O

### Expand characters

Expanded characters are displayed as shown below:

ex.) A B C

A□B□C□

# Chapter 7

---

## WORD PROCESSOR

First, place your typewriter in the word processor mode by pressing the **TW/WP** key. A selection menu will now appear on the display, consisting of the following 5 items:

▲PRESS 1 TO 5 FOR SELECTION  
1:CREATE-P 2:CREATE-N 3:EDIT 4:PRINT 5:DELETE

### Starting a file

There are two ways to create a new file:

#### 1. CREATE-P:

"Create and Print" for the creation of a file to be stored in memory and printed in the line by line mode. This allows you to make changes only one line at a time in the text.

#### 2. CREATE-N:

"Create and No-print" for the creation of a file to be stored in memory for later printing. This mode is the same as the edit mode that you can make changes anywhere in the text.

### Changing a file

#### 3. EDIT:

To edit your stored files to be changed to fit your present purpose. In this mode you can add, delete, move, and copy to a file already stored in memory.

### Printing a file

#### 4. PRINT:

To print a file stored in memory. While printing a file, you can still change a word, add or skip text by pressing the **CODE + S CODE** keys during file preparation (printing is automatically interrupted at their position), or the **CODE + STEP** keys to stop printing temporarily.

### Deleting a file

#### 5. DELETE:

To delete a file stored in memory.

### Status line

In the word processor mode, the status line is not constantly displayed, so press the **CODE + STATUS** keys to display the current set up of your typewriter.

### Notes:

1. You can store up to 63 files including the text and phrase files in the memory.
2. A maximum capacity of each file is 15 Kbytes.

## File Creation

You have two choices for file creation. One involving printing during creation, and the other involving creation without printing but offering wide editing possibilities. You have a further selection between two types of files; text and phrase files.

### Text file

A text file is used for entering text with format and layout information.

To create a text file, call the selection menu by pressing the **TW/WP** key and then press either the "1" or "2" key to choose a file creation mode. If there are already 63 files stored the display will inform you with the message "TOO MANY FILES" and a beep will sound. You have to delete a file with "5" key to create or store a new file.

The display will now ask you to name the file to be created. The name must consist of no more than 8 characters which may use letters, numbers and the hyphen.

```
NAME FILE: █
```

This file name is input with the **RETURN** key, and may be edited prior to input with the backspace, correction and word out functions.

Once the file name has been input, the display will clear and the cursor moves to the left end of the lower line and awaits your input. In the **CREATE-P** mode, the counter on the right end of the lower line will show the number of columns between the cursor and the right margin, while in the **CREATE-N** mode there is no counter and all 80 columns of the display may be used.

ex.) **CREATE-P**

```
—                                     ◀65
```

You may now begin typing. Your text will be displayed on the lower line until the carrier return takes place. The cursor returns to the left end of the second line and that line moves up to the first line. All format and typing functions may be recorded into a text file. In the event that the capacity of an each file exceeds 15 Kbytes while you are typing, the display will inform you with the following message and a beep will sound. No more text may be input after this, but everything which has been input so far will have already been stored in memory.

```
▲FILE MEMORY OVER
```

If the total memory of all files exceeds 52 Kbytes the display will inform you with the message "MEMORY FULL".

When the file has been completed, press the **END** key. The display will return to the selection menu.

**Notes:**

1. Any function can be registered in a text file, including line format data (pitch, line spacing, left and right margin settings, tabs, and decimal tabs)
2. A phrase file can be stored in a text file.
3. The keyboard selection can not be changed while registering and creating.

## Phrase file

The phrase file memory is particularly helpful to avoid the retyping of frequently used expressions, addresses and other groups of text. Up to 14 phrase files may be stored under single letter files names from A to N.

To enter a phrase file into memory, call the selection menu by pressing the **TW/WP** key and pressing the "1" or "2" key to choose a file creation mode.

The display will now ask you to name the file to be created. Enter a file name by holding down the **CODE** key and a letter from A to N. This file name is input with the **RETURN** key, and may be edited prior to input with the backspace, correction and word out functions.

ex.) entering A with the **CODE** key

NAME FILE: ◀A ▶█

Once the file name has been input, the display will clear and the cursor moves to the left end of the lower line to await your input. In the **CREATE-P** mode, the counter on the right end of the lower line will show the number of columns between the cursor and the right margin, while in the **CREATE-N** mode there is no counter and all 80 columns of the display may be used.

You may now begin typing. Your text will be displayed on the lower line until a carrier return takes place and that line moves up to the first line. In the event that your typewriter runs out of memory while you are typing, the display will inform you with the message "FILE MEMORY OVER" or "MEMORY FULL" and a beep will sound. No more text may be input after this, but everything which has been input so far will have already been stored in memory.

When the file is completed, press the **END** key. The display will return to the selection menu.

**Notes:**

1. It is possible to store up to 14 different phrase files in memory.
2. The only function that can be registered in a phrase file are bold, underline, centering between margins, right margin flush, and stop codes (covered later). A format cannot be registered.
3. The maximum memory of one phrase file is 15 Kbytes and the total amount of the 14 phrase files cannot exceed 52 Kbytes.



## Inserting a phrase file into a text file

The insertion of a phrase file into a text file may be performed in the CREATE-P, CREATE-N and EDIT modes.

### In the CREATE-P mode

Press the **CODE** + "A~N" keys for the name of the phrase file where you wish the phrase to be inserted. The text entered up to the cursor position will be printed, and the display will change to reflect the selected phrase file name followed by the beginning of the first sentence of that file on the upper line.

```
PHRASE ◀A ▶ [ inserting a phrase file into a text file, ]
_
```

Now press the **RETURN** key to store the phrase into the text file at the cursor position and to print it.

### In the CREATE-N and EDIT modes

Move the cursor right after the place where you wish the phrase to be inserted, then just press the **CODE** + "A~N" keys for the name of the phrase file. The upper line will be cleared and display the selected phrase file name followed by the beginning of the first sentence on the upper line.

```
PHRASE ◀A ▶ [ inserting a phrase file into a text file, ]
text file, changing a line format,
```

Now press the **RETURN** key. The phrase file contents are inserted on the left of the cursor position.

```
_____┘
text file, inserting a phrase file into a text file, changing a line format,
```

### Note:

After a phrase file has been called out for insertion, it may be cancelled before the **RETURN** key is pressed by pressing the **END** key.

## Changing the line format in a text file

With this function you can change the line format information of a text file (pitch, line spacing, left and right margin settings, tabs, and decimal tabs) within the file. The procedure differs between the CREATE-P mode and the CREATE-N and EDIT modes, both of which are explained next.

### In the CREATE-P mode

At the point at which you wish to change the line format, press the **RETURN** key to print the displayed line and place the cursor at the left side of the display. Now press the **CODE + FORMAT** keys. The following message will appear in the display.

▲SET NEW MARGIN/TAB

◀65

The carrier movement will now be enabled, so just enter the new line format values just as you would in the typewriter mode. To enter the new format, press the **CODE + FORMAT** keys and the display will change to reflect the new values you have just entered.

#### Notes:

1. To cancel the new format, just press the **END** key.
2. It is impossible to reset the format when in the paragraph indent mode.
3. If you press the **TAB** key, the type of tab reached will be displayed as "NORMAL TAB" or "DECIMAL TAB".

### In the CREATE-N and EDIT modes

As in both of these modes, the entire text, including formats, may be edited. Any format setting in the file may be changed at the head of the line.

To enter a new line format, move the cursor at the left end of the lower line, which is after the carrier return, with the **CURSOR** key, then press the **CODE + FORMAT** keys.

To change a format setting already present in the file, move the cursor to the line format symbol (  $\frac{1}{F}$  ) and press the **CODE + FORMAT** keys. In both cases the display will clear and the message "SET NEW MARGIN/TAB " will appear, along with the counter.

Set the format as you would in the typewriter mode. Only the format change keys may be used at this time.

To enter the new format, press the **CODE + FORMAT** keys. The original text display will return and a line format symbol (  $\frac{1}{F}$  ) will appear at the left of the lower line.

Line format settings (  $\frac{1}{F}$  ), with the exception of the initial one in the file, may be deleted by pressing the **CODE + DELETE** keys.

Line format setting may be cancelled by pressing the **END** key.

## File Editing

This section explains some functions you can use to edit a text in the CREATE-N or in EDIT modes.

### Cursor and display movement

The cursor may be moved throughout the file with the use of several cursor keys.

#### Cursor left and right

The cursor may be moved horizontally to the left and right with the ← key and → key, as well as the CODE + ← and CODE + → keys. The ← and → keys move the cursor one column at a time, while the CODE + ← and CODE + → keys move the cursor to the left and right ends of the display.

#### Cursor up and down

You may travel through the text vertically one line at time with the ↑ and ↓ keys.

#### File top and file end

The CODE + S FILE keys move the cursor immediately to the very top of the file, while the CODE + E FILE keys to the bottom end of the file.

#### Cursor movement by the RELOC key and the CODE + EXPR keys

The cursor may also be moved to the right of the position of the last character you input with the RELOC key, while the CODE + EXPR keys moves to the first character you input.

### Selecting a file for editing

Call the selection menu by pressing TW/WP key and the "3" key. The following will appear on the display. (The most recently used file name is displayed first.)

```
▲USE CURSOR KEYS FOR SELECTION THEN PRESS RETURN
FILE      TEXT: MODEL1  PHRASE: ◀A ▶                [ 8547]
```

A text file name is displayed next to TEXT and a phrase file name is displayed next to PHRASE. By pressing the ↑ and ↓ keys. The ← and → keys are used to select PHRASE and TEXT.

The counter gives the remaining amount of memory space. The cursor is under the text file name and if this is the file you want, just press the RETURN key.

The first line of the file is then displayed on the lower line. The cursor is on the left under the ( ⌘ ) mark for a text file, and under the first character for a phrase file.

## Search function

If you wish to search for a specific word in the text of a file without having to reread the entire text, you may use the search function. Your typewriter will perform the task for you, checking the entire text from the cursor position to the end of the file.

Press the **CODE + SEARCH** keys (**CODE + 7**). The display will ask you for a word to search for.

SEARCH: █  
phrase file, inserting a phrase file into a text file, changing a line format, ↵

Enter the word (not more than 32 characters) you wish to find. Capital and small characters are discriminated, so enter the word exactly the way it appears in the text. You can enter an accented character and a stop code, but no super/subscript, superimposed, bold or underlined characters.

SEARCH: line\_  
phrase file, inserting a phrase file into a text file, changing a line format, ↵

Press the **CODE + STEP** keys. When the word has been found, the cursor will stop after the last character of that word and the search mode will be cancelled and your typewriter will then return to the **CREATE-N** or **EDIT** modes.

have the following explanations. You will learn from text file, ↵  
phrase file, inserting a phrase file into a text file, changing a line\_format, ↵

To search for that word once again, it is not necessary to call out the search mode and reinput the word; merely press the **CODE + STEP** keys and the search will be repeated from the last position of the cursor.

If the word does not exist in the text, the display will inform you with the following message.

▲NOT FOUND  
phrase file, inserting a phrase file into a text file, changing a line\_format, ↵

Press any key to return to the edit display.

### Notes:

1. The search function may be canceled by pressing the **END** key.
2. The search word will be cleared by the **WORD OUT** and **CODE + LINE OUT** keys.
3. The last word searched for will remain in memory until the power is turned off.

## Replace function

This function works in a similar manner to the search function, except that it allows you to replace the word searched for with another.

Press the **CODE + REPLACE** keys (**CODE + 8**) and enter the word to be searched for. This operation is the same as for the search function. Now press the **RETURN** key. Your typewriter will ask you for the word with which to replace the one searched for with "REPLACE:"

```
REPLACE: █  
phrase file, inserting a phrase file into a text file, changing a line format, ↵
```

Enter the new word, then press the **RETURN** key again. Your typewriter will now ask you if the replacement is to be performed throughout the document with the following message on the display:

```
▲GLOBAL? PRESS RETURN (YES) OR STEP (NO)  
phrase file, inserting a phrase file into a text file, changing a line format, ↵
```

After your replying with the **RETURN** key, your typewriter will perform the replacement as directed with the following message on the display:

```
▲WORKING
```

The "COMPLETED" prompt will appear on the display after the replacements have been completed, and the cursor moves to the end of the file. Your typewriter will now return to the **CREATE-N** or **EDIT** modes.

If you answered negatively (with the **CODE + STEP** keys) to the global search query, you may perform the replacement function by selective replace. Press the **CODE + STEP** keys to advance to each search word and then press the **CODE + REPLACE** keys to replace the word.

In the event that the word was not found in the file, the display will inform you with the message "NOT FOUND" and the replace mode will be cancelled.

If the memory fills up, the display will inform you with the message "FILE MEMORY OVER" or "MEMORY FULL" and the replace mode will be cancelled.

This will return your typewriter to the **CREATE-N** or **EDIT** mode and the cursor will be displayed to the right of the old word.

### Notes:

1. If the character of an old word is bold or underlined, the new word will also be bold or underlined.
2. The replacement function will be canceled in progress by pressing the **END** key.
3. The replaced word will be cleared by the **WORD OUT** and **CODE + LINE OUT** keys.
4. The most recent search and replacement words will remain in memory until the power is turned off.
5. If you search and replace the superscript or subscript characters, they will be replaced within the normal mode.

## Block definition

This function allows you to move, copy and delete a whole section of text with a single operation.

### Defining a block

To work with a block of text, you must first define it.

First move the cursor to the position at which you wish the block to begin, then press the **MARK** key. Your typewriter will go into the block mode and a block symbol (  $\frac{B}{K}$  ) will appear at the left of the cursor position.

have the following explanations. You will learn from text file, phrase file, ↵  
 $\frac{B}{K}$  inserting a phrase file into a text file, changing line a format, ↵

Now move the cursor to where you wish the block to end and press the **MARK** key again. The block is now defined.

have the following explanations. You will learn from text file, phrase file, ↵  
 $\frac{B}{K}$  inserting a phrase file into a text file,  $\frac{B}{K}$  changing a line format, ↵

Once a block has been defined, the only keys which may be used are the cursor movement, **CODE + EXPR**, **RELOC**, **END** and **MARK** keys.

Block definition may be cancelled by moving the cursor immediately to the right of the block symbol and pressing the **MARK** or **END** key.

## Block move

After a block has been defined, it may be moved to a new location. Move the cursor to the location to which you wish to move the block, then press the **CODE + MOVE** keys. The block will be moved in front of the cursor position. The cursor will remain in the same position in relation to the text previous to the block movement and the block mode will be cancelled.

### Note:

When no line format code is included in the transferred block, the format of the new location will be adopted.

## Block copy

When you do not wish to move a section of text, but to copy it elsewhere, you should use the block copy function. After defining the block, move the cursor to the location (under the beginning of the character) at which you wish the block to be copied, then press the **COPY** key. The copied block will be placed in front of the cursor position.

If the memory fills up, the display will inform you with the message "FILE MEMORY OVER" or "MEMORY FULL" and the block copy mode will be cancelled.

## Block deletion

To delete an entire section of text all at once, merely define the text as a block and press the **CODE + DELETE** keys. That portion of the text will disappear and the block definition will be cancelled.

### Notes:

1. If the return symbol is deleted together with the block, the line following the block will be combined with the line preceding the block.
2. The first line format symbol of a file cannot be deleted with a block, while all the others can.

## Adding and printing text at the end of a file

Text may be added to the end of an existing file if desired.

Select the EDIT mode and call the desired text or phrase file, then press the **CODE + APPEND** keys. The last line of the file will appear on the upper line of the display, and text may be added and processed the same as in the CREATE-P mode.

### Notes:

1. Text added to text files will conform to format within that file.
2. If there is no return symbol at the end of the file text, the added text will be considered a direct continuation of the file text.
3. If the memory fills up, the display will inform you with the message "FILE MEMORY OVER" or "MEMORY FULL" and further entries will be printed, but not will be stored.

# Layout Functions

Some layout functions used in the word processor mode are used in a different way from the typewriter mode. This section will provide a quick survey of the differences, and will describe the display changes involved.

The following functions work exactly the same in the display mode and in the word processor mode: auto underline, bold, expand, super/subscript, word out/line out, and superimposed (permanent backspace). The word out function does not delete the function code while the line out function deletes it, but not the line format symbol (  $\frac{1}{2}$  ).

Whenever a text is stored, the various layout functions must somehow be signalled on the display. Otherwise it would be virtually impossible to edit them. So the following functions will be marked by a symbol: RETURN, TAB, DECIMAL TAB, LINE INDENT, PARAGRAPH INDENT, CENTERING, and RIGHT MARGIN FLUSH.

## Return

### In the CREATE-P mode

Pressing the RETURN key will cause the text entered to be printed and the carrier to move to the left end of the next line.

### In the CREATE-N and EDIT modes

Press the RETURN key and a return mark will appear, then the cursor will move to the left end of the next line.

## Tabs

### In the CREATE-P mode

Pressing the TAB key will cause the text entered to be printed and the carrier to move to the next tab position or the right margin. The lower line will be cleared and await further input. When the line is moved to the upper line, the tab symbol will be displayed.

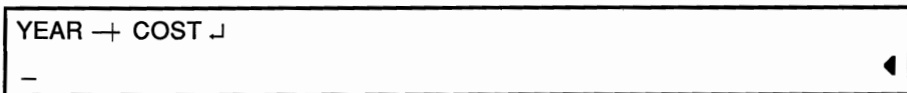

### In the CREATE-N and EDIT modes

Press the TAB key and it will be represented by a tab symbol to the left of the cursor.



## Decimal tabs

### In the CREATE-P mode

When the **TAB** key is pressed, the carrier will move to the next decimal tab to the right and "DECIMAL TAB" will appear on the display.



```
▲DECIMAL TAB
```

This display will disappear with the next input number, and the carrier will move to the left one space for each number input. When a decimal point is entered, the numbers already input and the decimal point will be printed, after which the display will go blank and the cursor moves to the left side.

A decimal tab symbol will appear on the display before the decimal tab characters. Input after the decimal point will be entered in the normal fashion.

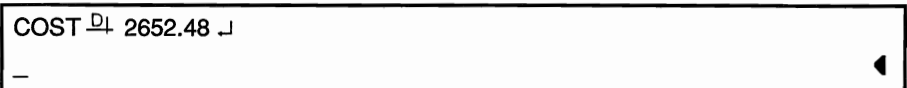

```
COST 2652.48
```

### In the CREATE-N and EDIT modes

Press the **TAB** key and a normal tab symbol will appear on the display. Your typewriter makes no differentiation between normal and decimal tabs.

## Line indent

### In the CREATE-P mode

To indent a line, press the **CODE + L IND** keys. The "LINE INDENT" message will appear in the display, but it will disappear when you begin to type. After a return operation, the line indent symbol will appear on the upper line as follows:

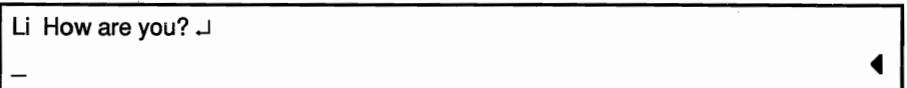

```
Li How are you?
```

### In the CREATE-N and EDIT modes

Press the **CODE + L IND** keys and a line indent symbol will appear to the left of the cursor.

## Paragraph indent

### In the CREATE-P mode

To indent a line to begin a paragraph, press the **CODE + P IND** keys. The "PARAGRAPH INDENT" message will appear in the display, but it will disappear when after first character is input. After a return operation, the paragraph indent symbol will appear on the upper line as follows:

```
Pi Low-profile keyboard, standard, international and symbol keyboards, ↵
—
```

### In the CREATE-N and EDIT modes

Press the **CODE + P IND** keys and a paragraph indent symbol will appear to the left of the cursor.

## Indent clear

### In the CREATE-P mode and CREATE-N/EDIT modes

Press the **CODE + IND CLR** keys to cancel the paragraph indent mode. An indent clear symbol will appear.

## Centering

### In the CREATE-P mode

Pressing the **CTR** key will cause the status display to appear and the carrier to move to the center of the page between the left and right margins or between the tabs. The cursor will move to the left of the lower line of the display.

```
◀WP▶ 1 1 10 1 STD M L/L CTR
—
```

Type your text, the status display will disappear. Now when the **TAB** or **RETURN** keys are pressed, the line will be printed, and on the display a centering symbol ( ⌘ ) for between margins or ( ⌘ ) for between the tabs will precede the line after the carrier return.

```
⌘ Electronic typewriter ↵
—
```

### In the CREATE-N and EDIT modes

After pressing the **CTR** key, a centering symbol ( ⌘ ) will appear to the left of the cursor and your typewriter will await input to be centered between the margins. Pressing the **CTR** key after pressing the **TAB** key will center text between the tabs, and a centering symbol ( ⌘ ) will appear.

### Note:

If the format is changed, it may become impossible to print all the centered text on one line. If this occurs, a carrier return will be inserted and the remaining text will be printed on the following line.

## Right margin flush

### In the CREATE-P mode

Pressing the **CODE + RMF** keys will cause the status display to appear and the carrier to move to the right margin. The cursor will move to the left of the lower line of the display.

Type your text, the status display will disappear. Now when the **TAB** or **RETURN** keys are pressed, the line will be printed, and on the display a right margin flush symbol (  $\bar{r}$  ) will precede the line. (This is exactly the same as the centering operation.)

### In the CREATE-N and EDIT modes

Press the **CODE + RMF** keys and a right margin flush symbol will appear to the left of the cursor and your typewriter will await input.

#### Note:

If the format is changed, it may become impossible to print all the right margin flushed text on one line. If this occurs, only the text fitting on the line will be printed and a carrier return will take place. The remaining text will be printed on the following line.

## Stop codes

This function comes in handy when you need to type a similar document with minor changes more than once. It allows you to command your typewriter to stop printing at a particular point so that the changes, such as names, addresses or other variable information may be entered.

### In the CREATE-P mode

Pressing the **CODE + S CODE** keys at the point where the stop code is desired will cause "STOP CODE" to appear on the display and the cursor to move to the left end of the lower line.



When input is resumed, the display will disappear and the stop code symbol will appear in the text after a carrier return.

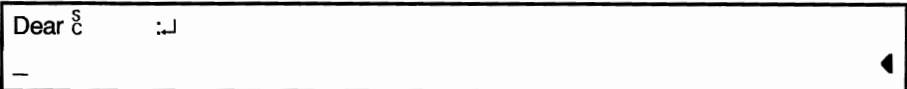

### In the CREATE-N and EDIT modes

Press the **CODE + S CODE** keys and a stop code symbol will appear to the left of the cursor.

## Page end setting

This function allows you to preset the maximum number of lines to be printed on a page. It is stored with the file, just as any other format or layout information.

Pressing the **CODE + P END** keys will cause the following message to be displayed, at which the desired number of lines (0~99) may be entered. The line number is according to the **LINE SPACE 1**. Only two digits may be entered. A third digit entered will cause the first two to scroll to the left, the first digit disappearing.

```
PAGE END SET: 0 █
```

Press the **RETURN** key to set this value.

### Notes:

1. Cancel before entry with the **TW/WP** or **END** key. This switches the mode respectively to the typewriter mode or the original display.
2. When the value is "0" no page end setting is entered.
3. The page end value for each file will be stored with the file contents.

## Printing a File

In order to print a file from memory, press the **TW/WP** key if you are in the typewriter mode or the **END** key if you are in the word processor mode to call the selection menu. Then press the "4" key. The following display will appear:

```
▲USE CURSOR KEYS FOR SELECTION THEN PRESS RETURN  
FILE   TEXT: MODEL1   PHRASE: ◀A ▶ [ 8547]
```

Now find the text or phrase file you wish to print using the **CURSOR** keys, and select the impact and justification or line by line mode. Press the **RETURN** key to print it. The following message will appear:

```
▲PRINTING
```

Pressing the **CODE + STEP** keys will cause the printing to pause. It may be resumed by pressing the **CODE + PRINT** keys. It may be halted completely by pressing the **END** key, after which your typewriter returns to the selection menu.

## Bidirectional printing

Printing is carried out in both directions, from left to right and then right to left in order to reduce carrier movement. However, the contents of the next line to be printed are checked beforehand, so that a line containing a stop code is printed from left to right, to allow changes to be input, as are lines with tabs, indentation, centering or right margin flush marks.

## Auto return

When a word extends to the right margin, that line is printed up to the preceding word, and a carrier return takes place to print the word on the next line. This function will be performed only during the CREATE-P mode.

### Notes:

1. An auto return will automatically work while printing a file or inserting a phrase file into a text file.
2. If a word extends beyond the right margin, it will not be wrapped to the next line, if it begins prior to the Hot Zone area.

## Page end

When a page end function (as described earlier) is reached during printing, the following message will be displayed on the upper line and the first line of the following page on the lower line.

▲PAGE END This is the last line of the page. ↵
---

At this time the **INDEX** or **R INDEX** key should be used to remove the sheet just printed and the **P INS** key used to insert a new page. Press the **CODE + PRINT** keys to resume printing. To stop printing here, press the **END** key and the mode returns to the selection menu.

## Printing a file during CREATE-N, EDIT

Printing may be done from the CREATE-N and EDIT modes, although stop codes will be ignored.

Press the **CODE + PRINT** keys. Printing will begin from the line occupied by the cursor, so if the entire file is to be printed, ensure that the cursor is at one line above the top of the file. On the display will appear the following message:

▲PRINTING
-----------

When the printing of the file has been completed, the last line of the file will appear in the display and your typewriter will return to the CREATE-N and EDIT mode. To interrupt the printing in progress, press the **END** key. Your typewriter will return to the CREATE-N or EDIT mode with the cursor on the line following the last one printed.

## Editing During Printing

A file may be interrupted for editing during printing either by pressing the **CODE + STEP** keys or with previously inserted stop codes; however, any text inserted in this way will not be saved to memory.

### Using the step function

Pressing the **CODE + STEP** keys while a file is being printed will cause the carrier to finish the line it is on, carrier returns and stops at the left margin. The upper line of the display will prompt you with the following message and the cursor will appear on the bottom line.

▲ PLEASE INSERT TEXT OR CHANGE PAPER  
keyboard selection. ↓

A single line of text may now be entered. The display will change to the line by line mode to insert new text. The message "PLEASE INSERT TEXT OR CHANGE PAPER" will appear on the display after a carrier return takes place. When additions have been completed, press the **CODE + PRINT** keys once again to resume printing.

### Stop codes

When you know beforehand where changes will have to be made in a document, you can enter stop codes while typing. Printing will automatically stop where stop codes are entered and the message "STOP CODE" appears, and awaits your input. Please refer to the previous explanation of stop codes.

The editing possibilities offered by the stop code are the same as those offered by the step function, and work in the same way.

### Using the skip function

The skip function may be used to remove unnecessary text from a file during printing without removing the text from memory.

Press the **CODE + STEP** keys to stop your typewriter temporarily during printing. Your typewriter will finish printing the line it is currently on, the carrier will return to the left margin, and the message "PLEASE INSERT TEXT OR CHANGE PAPER" will appear on the display. Using the ←, →, ↑ and ↓ keys, move the cursor past the portion of the text you wish to leave out of the printed document, then press the **CODE + PRINT** keys again. Your typewriter will ignore the text before the cursor and print only from the position of the cursor.

If, at this point, you press the **CODE + STEP** keys instead of the **CODE + PRINT** keys, your typewriter will print that one line, then the carrier returns and stops at the left margin.

## Text replacement during printing

This function allows you to replace a piece of text as you print with new text.

Press the **CODE + STEP** keys to stop your typewriter temporarily during printing. Your typewriter will finish printing the line it is currently on, the carrier will return to the left margin, and the message "PLEASE INSERT TEXT OR CHANGE PAPER" will appear on the display. Using the the ←, →, ↑ and ↓ keys, move the cursor past the portion of the text you wish to replace, and type in the text you wish to be printed. Your typewriter will go into the line by line mode and display the new text you input. Now press the **CODE + PRINT** keys to resume printing.

If, at this point, you press the **CODE + STEP** keys instead of the **CODE + PRINT** keys, your typewriter will print that one line, carrier return and stop at the left margin.

## Deleting a Text or Phrase File

With this function, you can erase a memory file.

Call the selection menu, then press the "5" key. The list of files stored in memory will be displayed. Use the cursor direction keys to select the file to be deleted and press the **RETURN** key. As a double check, the display will query you as to your choice with the message as follows:

```
DELETE FILE: MODEL 1 █? PRESS RETURN (YES) OR END (NO)
```

If that is the file and you want it erased, press the **RETURN** key. If it is not, or if you no longer wish to erase that file, merely press the **END** key to take the display back to the selection menu.

## Clearing all the memory

Your typewriter can be completely cleared of all the text memory and formats by pressing **CODE + SHIFT + DELETE** keys. The following message will appear on the display:

```
▲BACKUP MEMORY CLEARED
```

# SPELLING CHECKER

## Using the Spell Check Function

This machine is equipped with a spelling checker of American English with a dictionary of about 70,000 English words. It is as simple to use as typing, because the dictionary will check the words for you automatically as you type them!

To place your typewriter into the spell check mode, just press the **CODE + W SPELL** keys. It is released from the spell check mode in the same manner. After having been placed in the spell check mode, if a misspelled word (or a word not contained in the dictionary) is detected, the beep will sound, and in the direct type mode, the suspect word will appear on the lower line of the display.

```
◀TW▶ 1 1 10 1 STD M W.SPELL
SUSPECT WORD : -
```

This mode may be used when printing has been temporarily suspended for additional typing input as well.

The spell check mode will appear on the display when the **CODE + STATUS** keys are pressed in the word processor mode. The display looks like this:

```
◀WP▶ 1 1 10 1 STD M W.SPELL ▶
```

It is helpful to know what the dictionary recognizes as a word as it checks. The spell check function treats any continuous succession of letters followed by any of the following key inputs as a word for checking purposes:

- SPACEBAR
- PERMANENT SPACE
- TAB
- L IND
- P IND
- RELOC
- EXPR
- RETURN  
(except when preceded by a hyphen)
- CTR
- RMF
- OPERATE
- IND CLR
- END
- PAGE
- SLASH
- TW/WP
- TWO PERIODS in a row
- STOP CODE
- INDEX (pressing twice)
- R INDEX (pressing twice)

This does not include special characters such as parenthesis or quotation marks, unless these are preceded and followed by alphabetic characters with no intervening space.



## User Dictionary

When a word is typed that is not in the spell check dictionary, the spell checker will not be able to recognize the spelling of the word as valid even if it is spelled correctly. Although the spell checker dictionary contains about 70,000 English words, you may have occasion to type words into your typewriter that the dictionary does not contain, especially if your work often makes use of specialized or technical vocabulary. For this reason, the spell check function is equipped with a user dictionary with a capacity of about 255 seven-letter words to which the user may add words as necessary.

### Adding a word to the user dictionary

To add a word to the user dictionary, your typewriter must be in the spell check mode. Press the **CODE + W SPELL** keys to access the spell check mode, and the status display will appear (only in the type mode):

```
◀TW▶ 1 1 10 1 STD M W.SPELL ▶
```

Any word may be added to the user dictionary, to a maximum of 32 letters.

When the spell checker has detected a properly spelled word that is not in the spell check dictionary or previously saved into the user dictionary, it will beep. If you are sure that the word is spelled correctly and wish to add it to the user dictionary, merely press the **CODE + ADD** keys.

If the add is successful, on the upper line of the display will appear the following message:

```
▲WORD ADDED
```

If the added word that has exceeded 32 characters, the display will inform you as follow:

```
▲INVALID FOR DICTIONARY
```

Or "WORD TOO LONG" may appear and you cannot add word to the dictionary.

If the added word is already in the dictionary, the display will inform you as follows:

```
▲WORD ALREADY EXISTS
```

If a word contains numbers or symbols which cannot be entered in the dictionary, the display will inform you as follows and the beep will sound to inform you:

⚠INVALID FOR DICTIONARY

**Note:**

When the user dictionary has become full, the addition of another word will discard the first word in the dictionary in order to make room for the new addition.

### Removing words from the user dictionary

After a word which exists in the user dictionary has been checked with your typewriter in the Spell check mode, the word may be removed from the dictionary by pressing the **CODE + WS DEL** keys. If the deletion was successful, the display will inform you with the following message:

⚠WORD DELETED

If the word was not found, the following message will appear on the display:

⚠WORD NOT IN USER DICTIONARY

If the word contains invalid characters, the following message will appear and the beep will sound to inform you.

⚠INVALID FOR DICTIONARY

**Note:**

To be removed, the word must be typed in exactly the same manner in which it was previously added, including capitals, etc.

## Printing the User Dictionary

The content of the user dictionary may be checked by printing it out. Print out the user dictionary by pressing the **CODE + P DICT** keys in the typewriter mode. On the display will appear the following message:

```
▲PRINTING
```

Your typewriter will print "NUMBER OF WORDS" followed by the number for the amount of words contained in the user dictionary, then carriage return and your typewriter will begin printing out the contents in alphabetical order. When the printing finished, the carriage will return, and returns to the original display, and the beep will sound.

The printing may be stopped in progress by pressing the **CODE + STEP** keys. The carriage will finishing printing the line, return, and pause. On the display will appear the following message:

```
▲PRINT STOP
```

The **INDEX**, **R INDEX**, and **P INS** keys may be used at this time to change paper. Printing may be resumed by pressing the **CODE + PRINT** keys, or the print cancelled with the **END** key. If you press the **CODE + STEP** keys, you can print it line by line. If you press the **TW/WP** key, the display returns to the command selection menu.

## Word Scan Mode

When the spell check function explained above detects a misspelled word (or one not contained in the dictionary), the beep sounds and in the direct type mode, the suspect word appears on the lower line of the display.

```
◀TW▶ 1 1 10 1 STD M W.SPELL  
SUSPECT WORD: beautifull _
```

If you press the **RETURN** key now, the suspect word and any other input following it will be printed. If you press the **CODE + W SCAN** keys, the word scan function will scan the dictionary for possible alternative spellings of the suspect word. The following display will appear:

```
▲SCANNING  
SUSPECT WORD: beautifull
```

When a possible alternative is found, it will appear on the upper line of the display after the message "SUGGESTION:". There may be more suggestions other than the one appearing on the display, which may be viewed by pressing the → key.

```
SUGGESTION : beautiful beautifully
SUSPECT WORD : beautifull
```

If not, the scanner will continue the search for further alternates, and the message "SCANNING" will reappear in the upper line of the display.

When there are several suggested alternatives shown in the display, the cursor left and right keys may be used to scroll them and locate the desired word on the leftmost position. Pressing the RETURN key replaces the suspect word with the leftmost alternative.

If there is no suggested word, the following display will appear:

```
▲SUGGESTION NOT FOUND
```

#### Notes:

1. If the selected word with the word scan is too long to fit in the space, the message "WORD TOO LONG! PRESS LINE OUT KEY THEN RETURN KEY" will appear. Pressing the CODE + LINE OUT key deletes all the words located after the carrier to make space for the suggested word. Now press the RETURN key to print the suggested word. (direct type mode only)
2. If the selected word with the word scan is too long to overrun the right margin, the message "SUGGESTION IS TOO LONG" will appear. Press the M REL key and then the RETURN key to print the selected word.
3. If the word scan function is operated for the correct word in the display mode, the message "THE WORD IS CORRECT" will appear.

## Find

Find may also be used to detect misspelled words in the text. Your typewriter does not have to be in the spell check mode. When the CODE + FIND keys are pressed, the typewriter will begin to search for misspellings. When the typewriter finds a suspected word, the cursor will stop at the space just after the word. The detected word, if not misspelled, may be added to the user dictionary by pressing the CODE + ADD keys before you press any other keys.

```
▲FINDING
The find function detected misspelled_ words in text. ◀
```

Press the **CODE + FIND** keys again to continue the search.

Find may also be used together with the Word scan mode to search for and correct misspellings.

If there were no misspelled words in the selected text, the cursor will move, in the typewriter mode, to the relocated position, or in the Word processor mode, to the end of the file, and the following display will appear:

▲NO MISSPELLING FOUND

# APPENDIXES

---

## OPTIONAL ACCESSORY

### IF-20 Interface

Your typewriter becomes a letter-quality computer printer with the IF-20 Interface and is compatible with almost any computer with a Centronics Parallel port. Your typewriter is controlled directly by the computer during ON LINE operation.

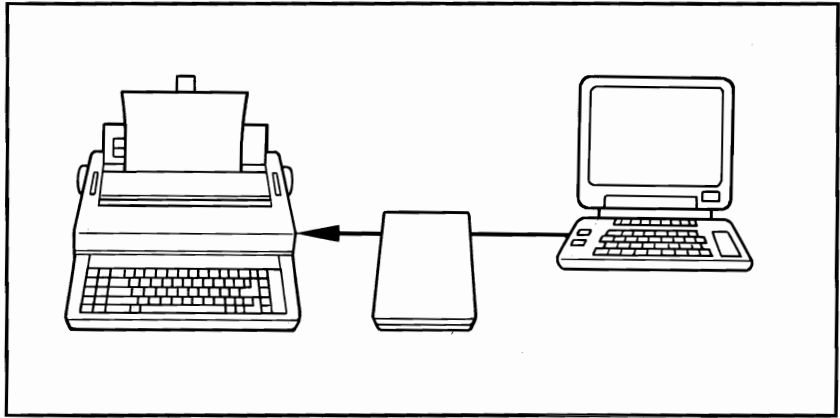

### Interface Connector

The Interface Connector is located on the right side of the typewriter. Before attaching the IF-20 to the typewriter, make sure that the typewriter is switched OFF.

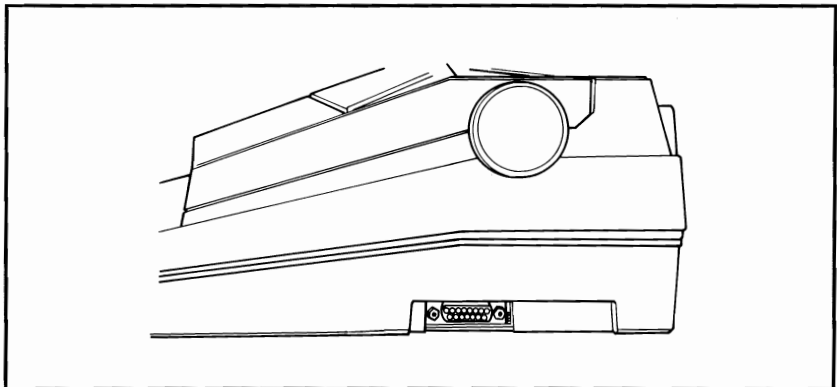

# MAINTENANCE

Brother has designed this electronic typewriter so that it will always be the best working friend of any typist. Understanding the likes and dislikes of your electronic typewriter will always keep it that way.

## MAINTENANCE & CLEANING

<u>Dislikes</u>	<u>Likes</u>
Water, alcohol, thinners and other organic solvents.	A dry cloth.
A rough old cloth.	A soft cloth.
Being cleaned inside.	

## INSIDE THE TYPEWRITER

<u>Dislikes</u>	<u>Likes</u>
Pins and paper clips (which may cause malfunctions).	Emptiness.
Should the platen become dirty, you can remove it from the typewriter in order to clean it. Simply pinch the tabs to the left and right of the platen and lift it out. Put it back in the same way.	

## OUTSIDE THE TYPEWRITER

<u>Dislikes</u>	<u>Likes</u>
Direct sunlight, heat,	A cool environment.
humidity and	A dry environment.
intense vibration.	A peaceful environment.
A sloping surface.	A flat surface.

## WHEN NOT TYPING

<u>Dislikes</u>	<u>Likes</u>
Being uncovered.	Cover it up!

## WHEN TYPING

<u>Dislikes</u>	<u>Likes</u>
Cassette daisy wheels, cassette ribbons and correction tapes from other manufacturers.	Buy Brother. Let's face it, only the best is good enough for your typewriter!

# TROUBLESHOOTING

Your Brother electronic typewriter has been precision manufactured to give you years of trouble-free use. But in the rare case that trouble does happen, you will probably be able to find the solution in the table below. If you cannot, please do not attempt to repair the typewriter yourself. Instead, please contact your nearest Brother dealer.

<b>What should I do...?</b>	<b>You should...</b>
Nothing works after the typewriter has been switched ON.	<ol style="list-style-type: none"><li>1. Check that the typewriter is plugged in.</li><li>2. Check that the top cover is firmly closed.</li></ol>
When I type, the characters do not print, or are faint.	<ol style="list-style-type: none"><li>1. Check that the cassette daisy wheel is inserted correctly.</li><li>2. Check to see if the cassette ribbon has not run out. If it has, then please replace it with a new one.</li><li>3. Check that the cassette ribbon is positioned properly.</li><li>4. Check that the Keyboard setting is selected correctly.</li></ol>
When I try to make a correction on the paper, I can't.	<ol style="list-style-type: none"><li>1. Check to see if the correction tape has run out. If it has, then please replace it with a new one.</li><li>2. Check that the correction tape is installed properly.</li><li>3. Check that the correction tape you have selected corresponds to the cassette ribbon you are using.</li></ol>
Nothing appears on the display.	<ol style="list-style-type: none"><li>1. Adjust the display contrast control up or down.</li></ol>



**What should I do if...?**

**You should...**

---

One of the following messages appear on the display:

**▲CHECK PRINTER**

Switch OFF your typewriter and switch it back ON again. If the same message appears, consult your Brother dealer.

**▲COVER OPEN**

Close the top cover.

**▲RAM DOWN**

Switch OFF your typewriter and try again. If the same message appears, consult your Brother dealer.

**▲ROM DOWN**

Consult your Brother dealer.

**▲BATTERY LOW ! TURNING UNIT OFF WILL CAUSE MEMORY LOSS**

Change the backup lithium battery. Clear the backup memory to continue the rest of your work.

# SPECIFICATIONS

<b>Printing Method</b>	Cassette daisy wheel (96 characters)
<b>Printing Speed</b>	16 characters per second
<b>Typing Pitches</b>	10 (maximum 117 characters per line) 12 (maximum 140 characters per line) 15 (maximum 175 characters per line)
<b>Line Spacing</b>	1, 1-1/2, and 2 lines
<b>Keyboard Memory</b>	48 characters
<b>Paper Capacity</b>	15.0"
<b>Typing Capacity</b>	11.7"
<b>Correction memory</b>	One line
<b>Keyboard</b>	46 keys (96 characters)
<b>Copying Capacity</b>	Original + 4
<b>Cassette Ribbon</b>	Correctable carbon ribbon (standard equipment) Muti-strike film One time film Nylon
<b>Correction Tape</b>	Lift-off correction tape (standard equipment) Cover-up correction tape
<b>Display</b>	LCD, 2 lines, 80 digits/line
<b>Memory</b>	52K (about 52,000 characters)
<b>Backup Memory</b>	About 3 years
<b>Backup Battery</b>	Lithium battery (No. CR2032, coin type, not rechargeable)
<b>Power Consumption</b>	0.55 A
<b>Typewriter dimensions</b>	18.4" (W) x 16.1" (D) x 5.3" (H)
<b>Typewriter weight</b>	17.4 lbs.

*Specifications are subject to change without notice.*

# QUICK REFERENCE FOR KEY FUNCTIONS

<b>Function</b>	<b>Combination</b>	<b>Operation</b>
ADD	<b>CODE + ADD</b>	Saves word to user's dictionary
ALL TAB CLR	<b>(CODE + T CLEAR) + REPEAT</b>	Clears all tabs
ALL PF CLR	<b>(CODE + PF CLR) + REPEAT</b>	Cancel all page formatting stop positions
APPEND	<b>CODE + APPEND</b>	Prints data input at the end of the file while adding it to the memory
BACKSPACE	<b>BKSP</b>	Direct type mode: moves the cursor one space to the left Display mode: deletes character to the left of the cursor
BOLD	<b>CODE + BOLD</b>	Sets and clears the BOLD mode
BS1	<b>CODE + BS1</b>	Moves the carrier 1/60" to the left (direct type mode only)
CAPS	<b>CODE + CAPS</b>	Sets and clears the CAPS LOCK mode
CODE	<b>CODE</b>	Used to access the green characters and function keys
COPY	<b>COPY</b>	Copies defined portion of text.
CORRECT	<b>CORRECT</b>	Direct type mode: automatic correction Display mode: deletes character to the left of the cursor
CTR	<b>CTR</b>	Centers words between tabs or margins
CURSOR	<b>↑, ↓, ←, →</b>	Moves the cursor one line or column in the indicated direction
DELETE	<b>CODE +DELETE</b>	Deletes the character at the cursor position
DT SET	<b>CODE + DT SET</b>	Sets a decimal tab
E FILE	<b>CODE + E FILE</b>	Moves the cursor to the end of file
END	<b>END</b>	Ends a file
E SET	<b>CODE + E SET</b>	Sets the end line
EXPAND	<b>CODE + EXPAND</b>	Sets and clears the EXPAND mode
EXPR	<b>CODE + EXPR</b>	Direct type mode: returns carrier to the left margin Display mode: moves cursor to top of the line currently occupied
EXPRESS CURSOR	<b>CODE + ←, →</b>	Moves cursor to top or end of the line or file

<b>Function</b>	<b>Combination</b>	<b>Operation</b>
<b>FIND</b>	<b>CODE + FIND</b>	Moves the carrier or cursor to the first misspelled word it finds
<b>FORMAT</b>	<b>CODE + FORMAT</b>	Typewriter mode: calls out saved line format Word processor mode: for modifying line format
<b>FRAMING</b>	<b>CODE + S</b>	Sets the FRAMING mode
<b>IMPACT</b>	<b>CODE + IMPACT</b>	For IMPACT setting selection
<b>IND CLR</b>	<b>CODE + IND CLR</b>	Clears PIND mode
<b>INDEX</b>	<b>INDEX</b>	Direct type mode: rotates platen up 1/12" to type subscript characters Display mode: input subscript
<b>INSERT</b>	<b>INSERT</b>	Toggles between the insert and overwrite modes in the display mode
<b>KB</b>	<b>CODE + KB</b>	For keyboard selection
<b>LINE</b>	<b>LINE</b>	For line spacing selection
<b>LINE OUT</b>	<b>CODE + LINE OUT</b>	Automatically deletes 1 line
<b>L IND</b>	<b>CODE + L IND</b>	Direct type mode: moves the carrier 5 characters to the right Display mode: moves the cursor 5 columns to the right
<b>L MAR</b>	<b>L MAR</b>	Sets the left margin
<b>MANUAL CORRECT</b>	<b>CODE + CORRECT</b>	Used to perform manual correction function
<b>MARK</b>	<b>MARK</b>	For block definition
<b>MICRO INDEX</b>	<b>CODE + INDEX</b>	Rotates platen up 1/48" (direct type mode only)
<b>MICRO R INDEX</b>	<b>CODE + R INDEX</b>	Rotates platen down 1/48" (direct type mode only)
<b>MOVE</b>	<b>CODE + MOVE</b>	Moves defined block of text
<b>M REL</b>	<b>M REL</b>	Releases right and left margins
<b>OPERATE</b>	<b>OPERATE</b>	For mode selection
<b>OPTION</b>	<b>OPTION</b>	For setting option modes
<b>PAGE</b>	<b>PAGE</b>	Moves carrier to the page format position
<b>PAGE SELECT</b>	<b>CODE + PAGE</b>	For page format selection

<b>Function</b>	<b>Combination</b>	<b>Operation</b>
P DICT	CODE + P DICT	Prints contents of user's dictionary
P END	CODE + P END	For setting the page end in the file
PERMANENT BACKSPACE	CODE + BKSP	For overstrike characters in the display mode
PERMANENT HYPHEN	CODE + -	Prevents automatic carrier return operation when typed in the hot zone while in the AUTO mode
PERMANENT SPACE	CODE + SPACEBAR	Prevents automatic carrier return operation when typed in the hot zone while in the AUTO mode
PF CLR	CODE + PF CLR	Cancels page formatting
PF SET	PF SET	For setting page formatting
P IND	CODE + P IND	Sets a temporary left margin
P INS	P INS	For automatic insertion
PITCH	PITCH	For pitch setting selection
PRINT	CODE + PRINT	Prints text from the line occupied by the cursor during the CREATE-N and EDIT modes
RELOC	RELOC	Direct type mode: moves carrier 1 pitch to the right of the last printed character Display mode: moves cursor to the right of the last input character
REPEAT	REPEAT	Repeats the last character typed
REPLACE	CODE + REPLACE	Searches for designated text, replacing it with another piece of designated text
RETURN	RETURN	Returns the carrier to the left margin and line feeds once
R INDEX	R INDEX	Direct type mode: rotates platen down 1/12" to type superscript characters Display mode: input superscript characters
R MAR	R MAR	Sets right margin
RMF	CODE + RMF	Types line flush to the right margin
S CODE	CODE + S CODE	Sets a stop code in the file
SEARCH	CODE + SEARCH	Searches a file for designated text
SELF DEMO PRINT	SHIFT + PITCH	Prints the self demonstration, the SPACEBAR or END key cancels printing.
S FILE	CODE + S FILE	Moves the cursor to the top of file
SHIFT	SHIFT	Places keyboard in upper case mode
SHIFT LOCK	SHIFT LOCK	Locks keyboard in upper case mode until the SHIFT key is pressed

<b>Function</b>	<b>Combination</b>	<b>Operation</b>
SPACEBAR	SPACEBAR	Moves the carrier one pitch to the right
S SET	S SET	Sets the start line
STATUS	CODE + STATUS	Displays mode status
STEP	CODE + STEP	Executes a search within a file
TAB	TAB	Moves the carrier to the next tab or decimal tab
T CLR	CODE + T CLR	Clears a tab
T SET	T SET	Sets a tab
TW/WP	TW/WP	A toggle switch for the typewriter and word processor modes
UNDLN	UNDLN	Selects underline mode
WORD OUT	WORD OUT	Correction function for removal of one word
W SCAN	CODE + W SCAN	Displays correction suggestions for misspelled words
WS DEL	CODE + WS DEL	Removes the word from the user's dictionary
W SPELL	CODE + W SPELL	Toggle for setting/releasing typewriter to/from spell check mode
BACK UP MEMORY CLEAR	CODE + SHIFT + DELETE	Clears the entire memory of all data

# INDEX

## A

- Accented characters 18, 53
- Adding and printing text at the end of a file 63
- Adding a word to the user dictionary 73
- All tab clear 25
- Auto carrier return 29
- Auto paper insert 19, 20
- Auto underline 28
- Automatic corrections 38

## B

- Backspace 1 27
  - and word out 41, 42
- Backspacing 26, 27
- Backup battery 7, 45, 46
- Battery 7
- Battery installation 7
- Block copy 63
- Block definition 62
- Block deletion 63
- Block move 63
- Bold characters 28, 52

## C

- Caps lock 26
- Calling a line format from memory 46
- Calling a page format from memory 47
- Cassette daisy wheel 9, 10
- Cassette ribbon 11, 12
- Centering 31, 32, 66
  - between margins 31
  - between tabs 32
- Clearing the backup memory 48
- Clearing all the memory 71
- Code key 19
- Continuous underline mode 28
- Corrections 38, 39, 40, 41, 42, 43, 50, 51
  - centered text 31, 32, 40
  - deletion 42, 51
  - insertion 41, 51
  - justified text 34, 40
  - line out 43, 51
  - overwrite 50
  - right margin flushed text 33, 67
  - word out 40, 41, 42, 51
- Correction tape 12, 13
- Create-P mode 54, 57, 58, 64, 65, 66, 67
- Create-N mode 54, 57, 58, 64, 65, 66, 67, 69
- Cursor and display functions 50, 59

## D

- Daisy wheel 9, 10
- Dead keys 18, 53
- Decimal tabs 24, 65
- Deletion 71
  - text file 71
  - phrase file 71
- Demonstration printing (see "Self demonstration printing")
- Diagnostics 8
- Dimensions 82
- Display 14, 15, 16
- Display functions (see "Cursor and display functions")
- Display mode 49
- Display operations 16

## E

- Editing during printing 70
- Edit mode 54, 57, 58, 59, 64, 65, 66, 67, 69
- Ending line set 22
- Expand characters 29, 53
- Express backspace 27
- Express cursor left 50
- Express cursor right 50
- Extra keys 18

## F

- Features 1
- File creation 55
  - phrase file 56
  - text file 55
- File editing 59
- Find 77
- Fractional numbers 52
- Framing 36
- Functions requiring a special display 52

## H

- Hot zone 30

## I

- Impact setting 17
- Indent clear 35, 66
- Indentation 35
  - line 35, 65
  - paragraph 35, 66
- Index 44, 52
- Inserting paper 19, 20, 21
  - automatically 19, 20
  - manually 21



Inserting a phrase file into a text file 57  
Installing the lithium battery 7  
International keyboard 17

## J

Justification 34

## K

Keyboard 3  
    international keyboard 17  
    standard keyboard 17  
    symbol keyboard 17  
Keyboard selection 17  
Key function quick reference 83

## L

Layout functions 64  
Left margin 23  
Line by line processing 49  
Line format change within a text file 57  
Line format memory 46  
    storing a line format in memory 46  
    calling a line format from memory 46  
Line indent 35, 65  
Line out 43, 51  
Line spacing setting 18  
Lithium battery 7  
Liquid crystal display 14, 15

## M

Maintenance 79  
Manual correction 39  
Manual paper insertion 21  
Margin release 23  
Margin scale 5  
Margins 23  
Memory function 45  
Memory all clear 48, 71  
Micro index 44  
Micro reverse index 44

## N

Normal tabs 24

## O

Optional accessory 78  
Overwrite 50

## P

- Page end 22, 68, 69
- Page format all clear 48
- Page format clear 48
- Page format memory 47
  - calling a page format from memory 47
  - storing a page format to memory 47
- Paper insertion 19, 20, 21
- Paper thickness control 21
- Paragraph indent 35, 66
- Permanent backspace 27, 53
- Permanent hyphen 30
- Permanent space 30
- Pitch setting 19
- Power 7, 8
- Pre-set margins 23
- Printing a file 68
- Printing the user dictionary 75

## Q

- Quick reference for key functions 83

## R

- Relocation 38, 41, 42, 43
- Removing words from the user dictionary 74
- Repeat function 27
- Replace function 61
- Replacing the cassette ribbon 11, 12
- Replacing the correction tape 12, 13
- Replacing the lithium battery 7
- Replacement of text during printing 71
- Reverse index 44, 52
- Right margin 23
- Right margin flush 33
- Right margin justification 34

## S

- Search function 60
- Self diagnosis 8
- Self demonstration printing 1
- Self repeat 27
- Setting the ending line 22
- Setting the starting line 22
- Skip function 70
- Special display code table 15
- Specifications 82
- Spelling checker 72
- Standard keyboard 17
- Starting line set 22
- Status display 15
- Status key 15

Step function 70  
Stop codes 70  
Storing a line format to memory 46  
Storing a page format to memory 47  
Subscript (see "Index")  
Superscript (see "Reverse index")  
Symbol codes 15  
Symbol keyboard 17

## T

Tab clear 25  
Tabs 24, 64  
Text replacement during printing 71  
Troubleshooting 80, 81  
Typewriter mode 16  
Typing pitch 19

## U

Underlined characters 28, 52  
    continuous 28  
    word 28  
Upper case characters 26  
User dictionary 73  
    Adding a word to the user dictionary 73  
    Removing words from the user dictionary 74

## W

Weight of typewriter 82  
Word out 40, 41, 42, 51  
Word processor mode 16, 54  
Word scan mode 75, 76









**brother®**



## Free Manuals Download Website

<http://myh66.com>

<http://usermanuals.us>

<http://www.somanuals.com>

<http://www.4manuals.cc>

<http://www.manual-lib.com>

<http://www.404manual.com>

<http://www.luxmanual.com>

<http://aubethermostatmanual.com>

Golf course search by state

<http://golfingnear.com>

Email search by domain

<http://emailbydomain.com>

Auto manuals search

<http://auto.somanuals.com>

TV manuals search

<http://tv.somanuals.com>