

BAS-511

INSTRUCTION MANUAL

Please read this manual before using the machine.

Please keep this manual within easy reach for quick reference.

AUTOMATIC LOCKSTITCH BUTTON HOLER

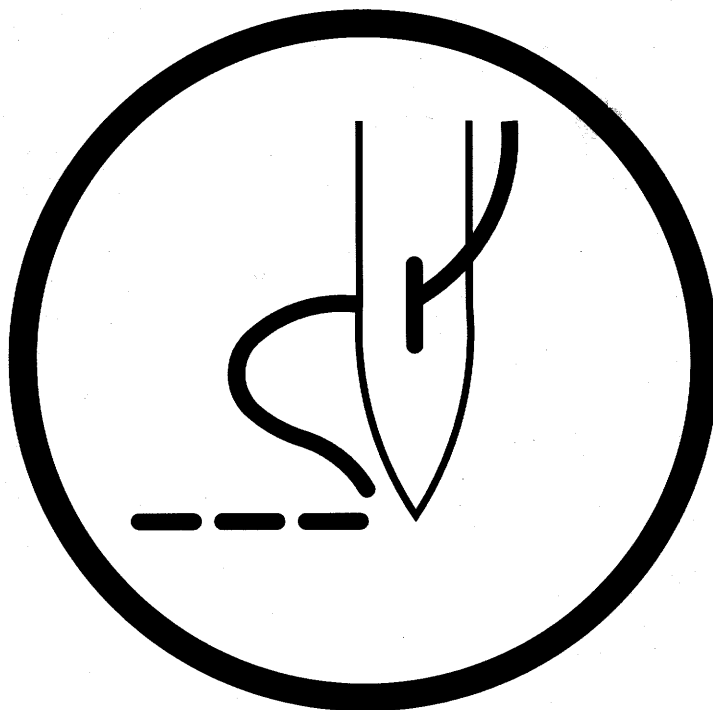

CONTENTS

1. MAIN PART NAMES	1
2. SPECIFICATIONS	1
3. SET-UP	2
3-1. Positioning the machine	2
3-2. Stacker height adjustment	2
3-3. Spool stand installation	3
3-4. Bodice support	3
3-5. Air perssure adjustment	4
3-6. Threading	5
3-7. Lubrication	6
3-8. Adding oil	6
3-9. Adjusting the rotary hook lubrication amount	6
4. OPERATIONS	7
4-1. Explanation of the operation panel and main unit switches	7
4-2. Operational set-up	11
4-3. Inputting programs	12
4-3-1. Inputting a program for sewing regular-interval buttonholes	12
4-3-2. Inputting a program for sewing irregular-interval buttonholes	14
4-4. Table feed	16
4-4-1. Checking clamp movement and stacker operation	16
4-4-2. Moving the clamp to the desired position and sewing	18
4-5. Trial sewing	19
4-6. Setting a workpiece	20
4-7. Adjusting	21
4-7-1. Margin-to-seam width adjustment	21
4-7-2. Guider adjustment	22
4-7-3. Tilting the machine head	23
4-8. Sewing	24
4-8-1. Standard sewing	24
4-8-2. When using the sub-table set or table set	25
4-8-3. Setting servo feed	26
4-8-4. Sewing long garments	26

4-9. One-pedal specifications	27
4-10. EMERGENCY switch/Troubleshooting	28
4-10-1. Using the emergency stop function	28
4-10-2. If a TROUBLE indicator illuminates	30
4-11. Setting the thread counter	31
4-12. Setting the correction value	32
4-13. Clamp L adjustment	34
4-13-1. When sewing men's clothing	34
4-13-2. When sewing ladies' clothing	34
4-14. Leading edge guide timing adjustment	35
4-14-1. Edge guide operation	35
4-14-2. Setting the edge guide timing	35
4-15. Using the stacker	36
4-16. Sewing counter	38
4-17. To change the buttonhole size	39
4-18. Changing the clamp (R) installation position	41
4-19. Error code list	42

Thank you very much for buying a BROTHER sewing machine. Before using your new machine, please read the safety instructions below and the explanations given in the instruction manual.



With industrial sewing machines, it is normal to carry out work while positioned directly in front of moving parts such as the needle and thread take-up lever, and consequently there is always a danger of injury that can be caused by these parts. Follow the instructions from training personnel and instructors regarding safe and correct operation before operating the machine so that you will know how to use the machine correctly.

SAFETY INSTRUCTIONS

1 Safety indications and their meanings

This instruction manual and the indications and symbols that are used on the machine itself are provided in order to ensure safe operation of this machine and to prevent accidents and injury to yourself or other people. The meanings of these indications and symbols are given below.

Indications

 DANGER	The instructions which follow this term indicate situations where failure to follow the instructions will almost certainly result in death or severe injury.
 CAUTION	The instructions which follow this term indicate situations where failure to follow the instructions could cause injury when using the machine or physical damage to equipment and surroundings.

Symbols



----- This symbol(\triangle) indicates something that you should be careful of. The picture inside the triangle indicates the nature of the caution that must be taken.
(For example, the symbol at left means "beware of injury".)



----- This symbol(\otimes) indicates something that you must not do.



----- This symbol(\bullet) indicates something that you must do. The picture inside the circle indicates the nature of the thing that must be done.
(For example, the symbol at left means "you must make the ground connection".)

2 Notes on safety

DANGER



- Wait at least 5 minutes after turning off the power switch and disconnecting the power cord from the wall outlet before opening the face plate of the control box. Touching areas where high voltages are present can result in severe injury.

CAUTION

Installation



- Machine installation should only be carried out by a qualified technician.



- Contact your Brother dealer or a qualified electrician for any electrical work that may need to be done.



- The sewing machine weighs more than 230 kg. The installation should be carried out by two or more people.



- Do not connect the power cord until installation is complete, otherwise the machine may operate if the start switch or the foot switch is pressed by mistake, which could result in injury.



- Be sure to connect the ground. If the ground connection is not secure, you run the risk of receiving a serious electric shock.



- Be sure to wear protective goggles and gloves when handling the lubricating oil and grease, so that they do not get into your eyes or onto your skin, otherwise inflammation can result.

Furthermore, do not drink the oil or eat the grease under any circumstances, as they can cause vomiting and diarrhoea.

Keep the oil out of the reach of children.



- Avoid setting up the sewing machine near sources of strong electrical noise such as high-frequency welding equipment. If this precaution is not taken, incorrect machine operation may result.

Sewing



- This sewing machine should only be used by operators who have received the necessary training in safe use beforehand.



- The sewing machine should not be used for any applications other than sewing.



- Attach all safety devices before using the sewing machine. If the machine is used without these devices attached, injury may result.



- Turn off the power switch at the following times, otherwise the machine may operate if the start switch or the foot switch is pressed by mistake, which could result in injury.

- When replacing the needle
- When not using the machine and when leaving the machine unattended



- Do not touch any of the moving parts or press any objects against the machine while sewing, as this may result in personal injury or damage to the machine.



- If an error occurs in machine operation, or if abnormal noises or smells are noticed, immediately turn off the power switch. Then contact your nearest Brother dealer or a qualified technician.



- If the machine develops a problem, contact your nearest Brother dealer or a qualified technician.

⚠ CAUTION

Cleaning



- Turn off the power switch before starting any cleaning work, otherwise the machine may operate if the start switch or the foot switch is pressed by mistake, which could result in injury.



- Be sure to wear protective goggles and gloves when handling the lubricating oil and grease, so that they do not get into your eyes or onto your skin, otherwise inflammation can result. Furthermore, do not drink the oil or eat the grease under any circumstances, as they can cause vomiting and diarrhoea. Keep the oil out of the reach of children.

Maintenance and inspection



- Maintenance and inspection of the sewing machine should only be carried out by a qualified technician.



- Ask your Brother dealer or a qualified electrician to carry out any maintenance and inspection of the electrical system.



- Turn off the power switch and disconnect the power cord from the wall outlet at the following times, otherwise the machine may operate if the start switch or the foot switch is pressed by mistake, which could result in injury.

- When carrying out inspection, adjustment and maintenance
- When replacing consumable parts such as the rotary hook and knife



- Disconnect the air hoses from the air supply and wait for the needle on the pressure gauge to drop to "0" before carrying out inspection, adjustment and repair of any parts which use the pneumatic equipment.



- If the power switch and air need to be left on when carrying out some adjustment, be extremely careful to observe all safety precautions.



- Use only the proper replacement parts as specified by Brother.



- If any safety devices have been removed, be absolutely sure to re-install them to their original positions and check that they operate correctly before using the machine.



- Any problems in machine operation which result from unauthorized modifications to the machine will not be covered by the warranty.

3 Warning labels

★ The following warning labels appear on the sewing machine. Please follow the instructions on the labels at all times when using the machine. If the labels have been removed or are difficult to read, please contact your nearest Brother dealer.

1

	▲ DANGER	▲ GEFAHR	▲ DANGER	▲ PELIGRO
	Hazardous voltage will cause injury. Turn off main switch and unplug power cord before opening this cover.	Hochspannung verletzungsgefahr! Vor Öffnen des Gehäuses Hauptschalter ausschalten und Netzstecker ziehen!	Un voltage non adapté provoque des blessures. Pour ouvrir cette plaque, couper le contact general de la machine et debrancher le cable d'alimentation.	Un voltaje inadecuado puede provocar las heridas. Antes de abrir esta tapa, desconecte la máquina y desenchufela de la red.

2

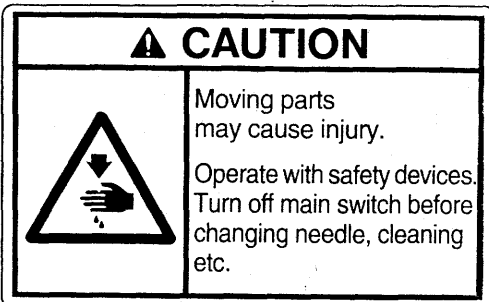

3 Direction of operation



Safety devices: Pulley cover, Belt cover, Stacker guard, Thread take-up cover, Eye guard, Finger guard, etc.

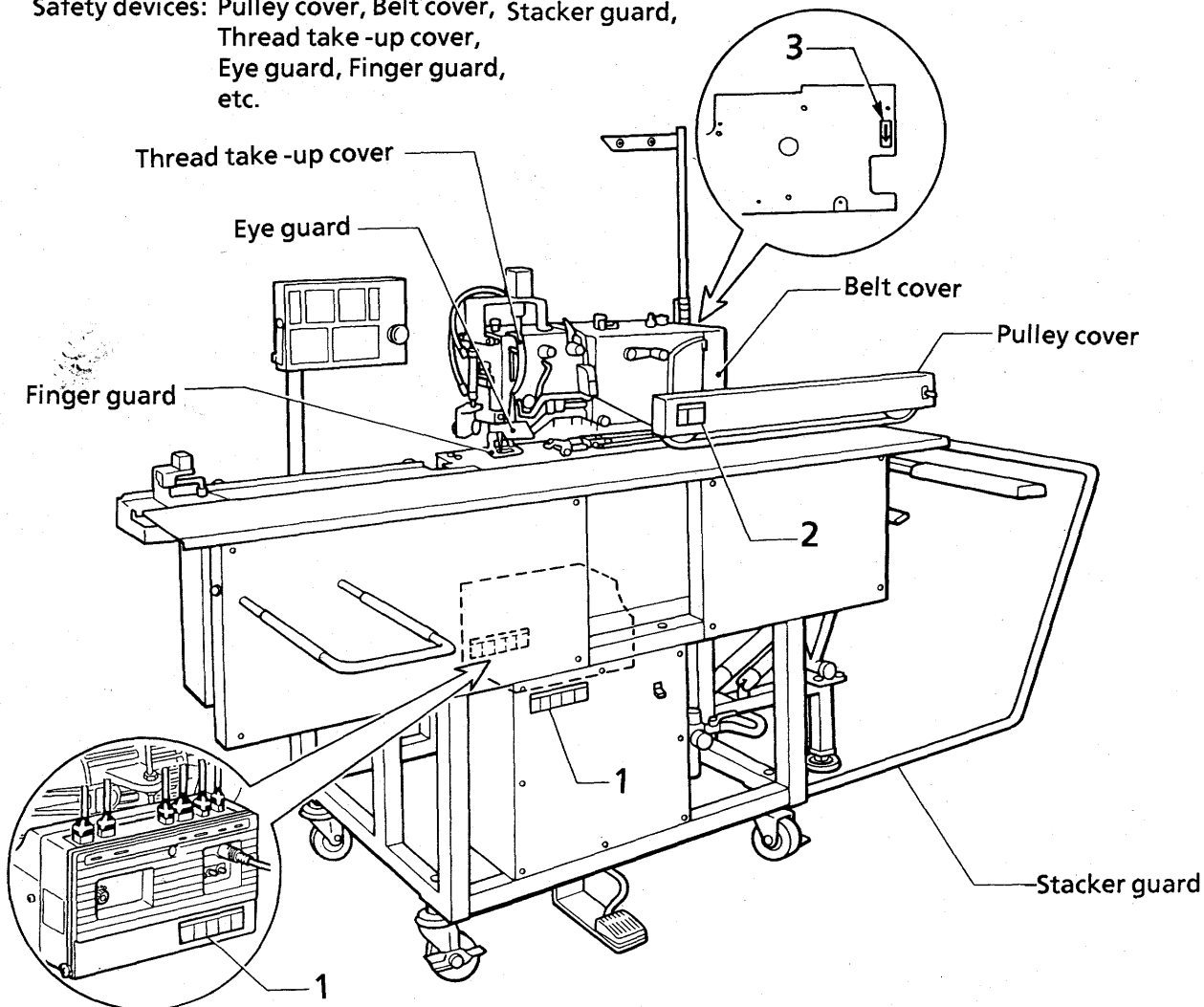

1. MAIN PART NAMES

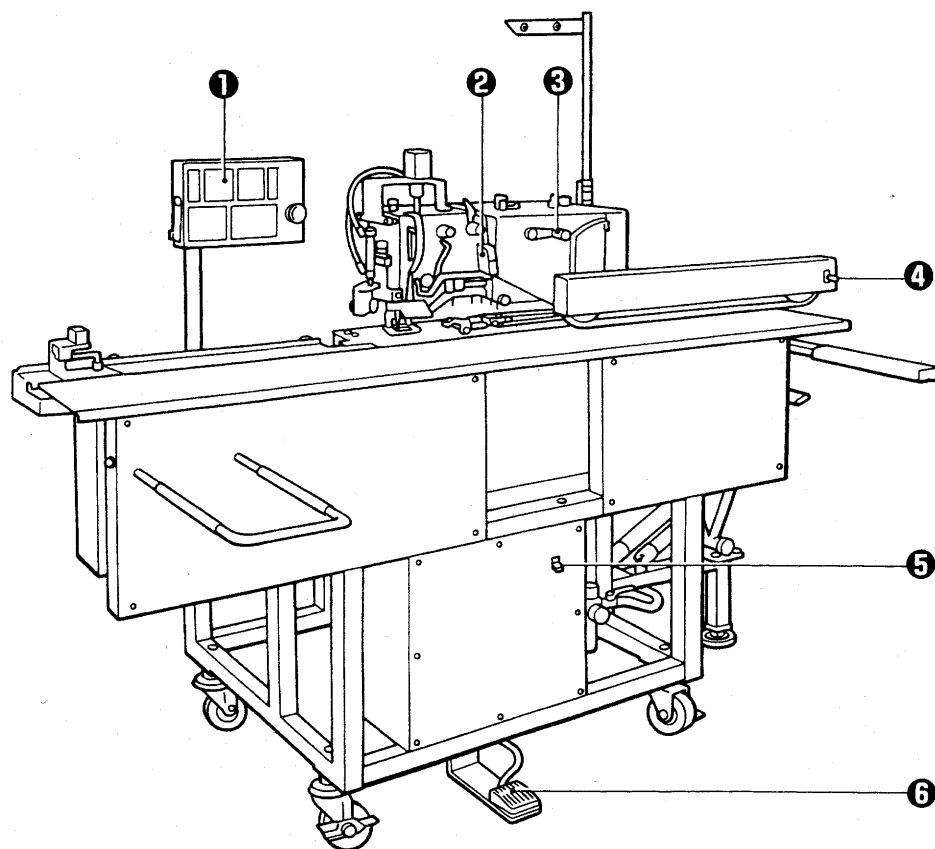

❶ Operation panel

❷ Start switch

❸ Handle

❹ Stacker switch

❺ Power switch

❻ Foot switch

2. SPECIFICATIONS

Model		LH4-B816NP
Buttonhole length (knife width)		11 - 22 mm
Dimension	A	Men's: 55-399 mm or 45 - 389 mm Ladies': 45 - 389 mm
	B	7 - 20 mm
	C	150 - 600 (1150) mm
	D	25 - 600 mm
Buttonhole number		2 - 20
Pattern storage capacity		20 patterns
Workpiece feed		Clamp feed
Presser bar stroke		10 mm
Needle		SY1906

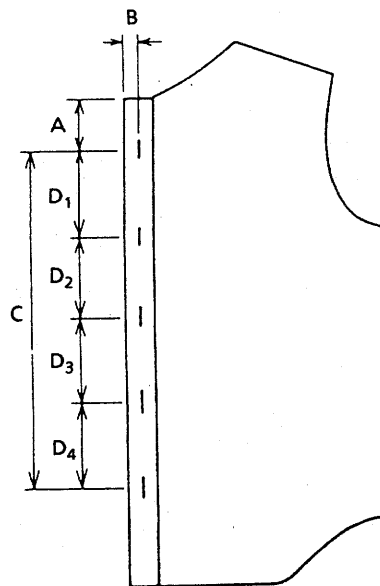

* Always refer to the user's manual for LH4-B816NP.

* The value above in parentheses applies for sewing a long garment.

3. SET-UP

⚠ CAUTION

- ⊘ Machine installation should only be carried out by a qualified technician.
- ! Contact your Brother dealer or a qualified electrician for any electrical work that may need to be done.
- ! The sewing machine weighs more than 230 kg. The installation should be carried out by two or more people.
- ! Avoid setting up the sewing machine near sources of strong electrical noise such as high-frequency welding equipment. If this precaution is not taken, incorrect machine operation may result.
- ⊘ Do not connect the power cord until installation is complete, otherwise the machine may operate if the start switch or the foot switch is pressed by mistake, which could result in injury.
- ⚡ Be sure to connect the ground. If the ground connection is not secure, you run the risk of receiving a serious electric shock.

3-1. Positioning the machine

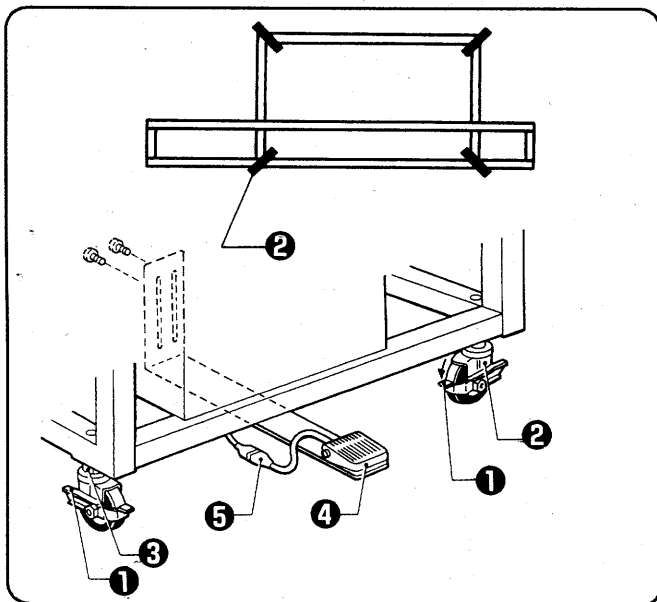

1. After deciding where the power table is to be installed, lower lever ① to lock caster ②. Lower lever ① to disengage the lock and roll the caster.
2. To adjust the table height, loosen nut ③, and turn caster ②.
(NOTE)
 - Be sure to firmly retighten nut ③ after adjusting the height.
3. Install the foot switch ④ from the rear of the power table. After installation, connect the connector ⑤.
4. Set the casters ② at an angle to the table.
(See the figure at left.)

3-2. Stacker height adjustment

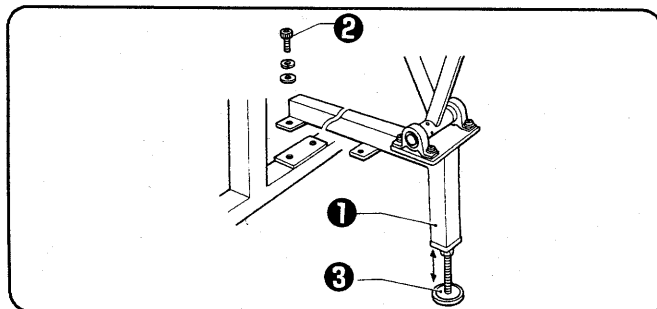

- Install the stacker ① to the power table with the hexagonal bolt ②.
Adjust level seat ③ so that the stacker ① does not tilt.

3-3. Spool stand installation

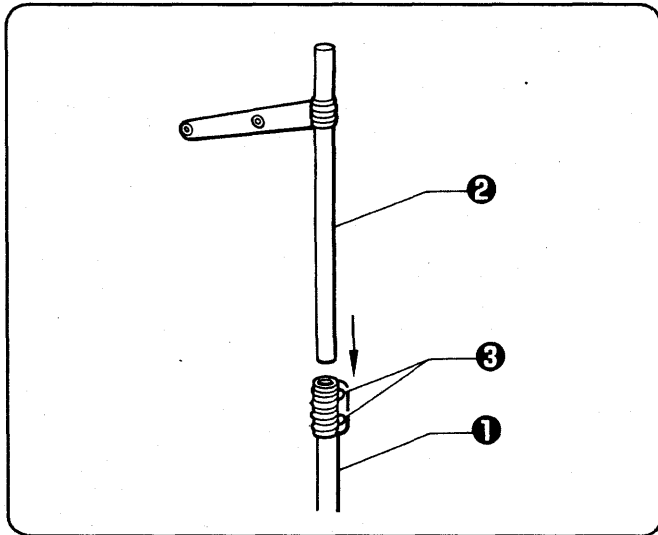

Insert column pipe ② into column pipe D ①, and then tighten the two screws ③.

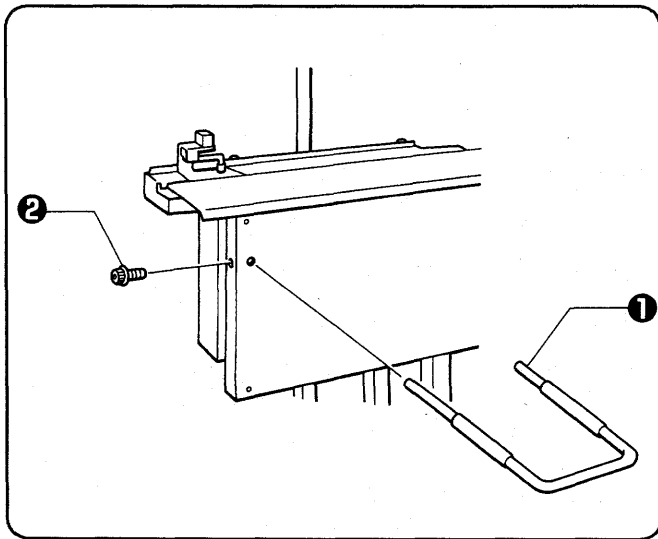

3-4. Bodice support



Install the bodice support ① with four Allen bolts ②.

3-5. Air pressure adjustment

⚠ CAUTION

- 
 • If the power switch and air need to be left on when carrying out some adjustment, be extremely careful to observe all safety precautions.
- 
 • Disconnect the air hoses from the air supply and wait for the needle on the pressure gauge to drop to "0" before carrying out inspection, adjustment and repair of any parts which use the pneumatic equipment.

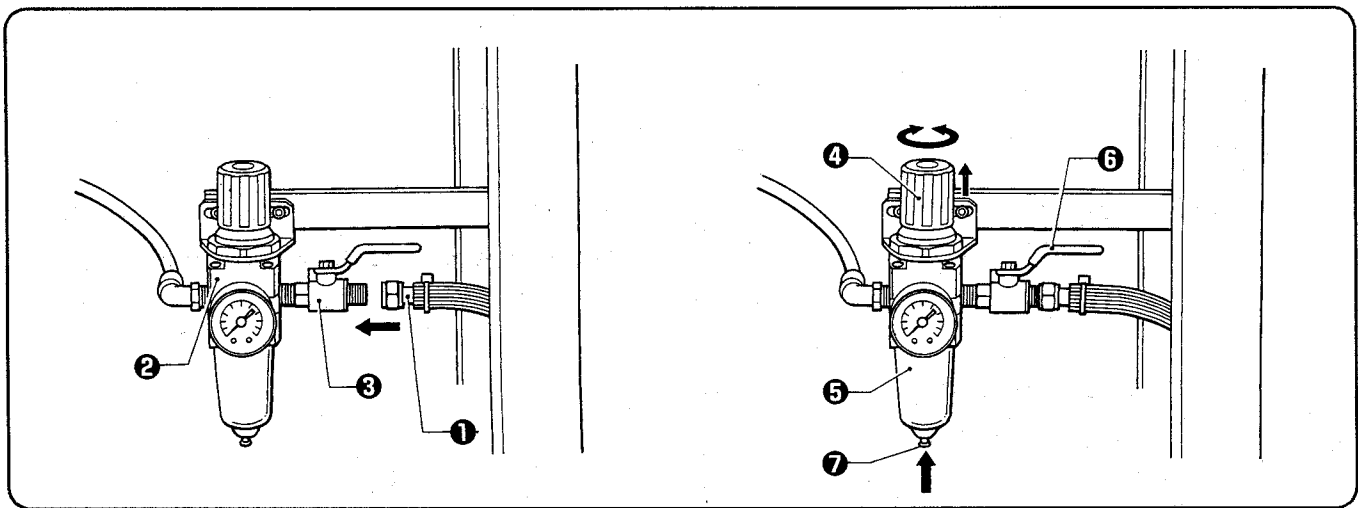

1. Connect hose ① to the union ③ of the air unit assembly ②.
2. Use with the air pressure set at 0.49 MPa (5 kg/cm²).
3. If water collects inside the bottle ⑤, close the air cock ⑥, and press the button ⑦ to drain the water.

(NOTE)

 - When cock ⑥ is opened, be careful of the stacker bar.

3-6. Threading

CAUTION



- Turn off the power switch at the following times, otherwise the machine may operate if the start switch or the foot switch is pressed by mistake, which could result in injury.
 - When replacing the needle
 - Threading

- Thread the machine as shown in the figure below.

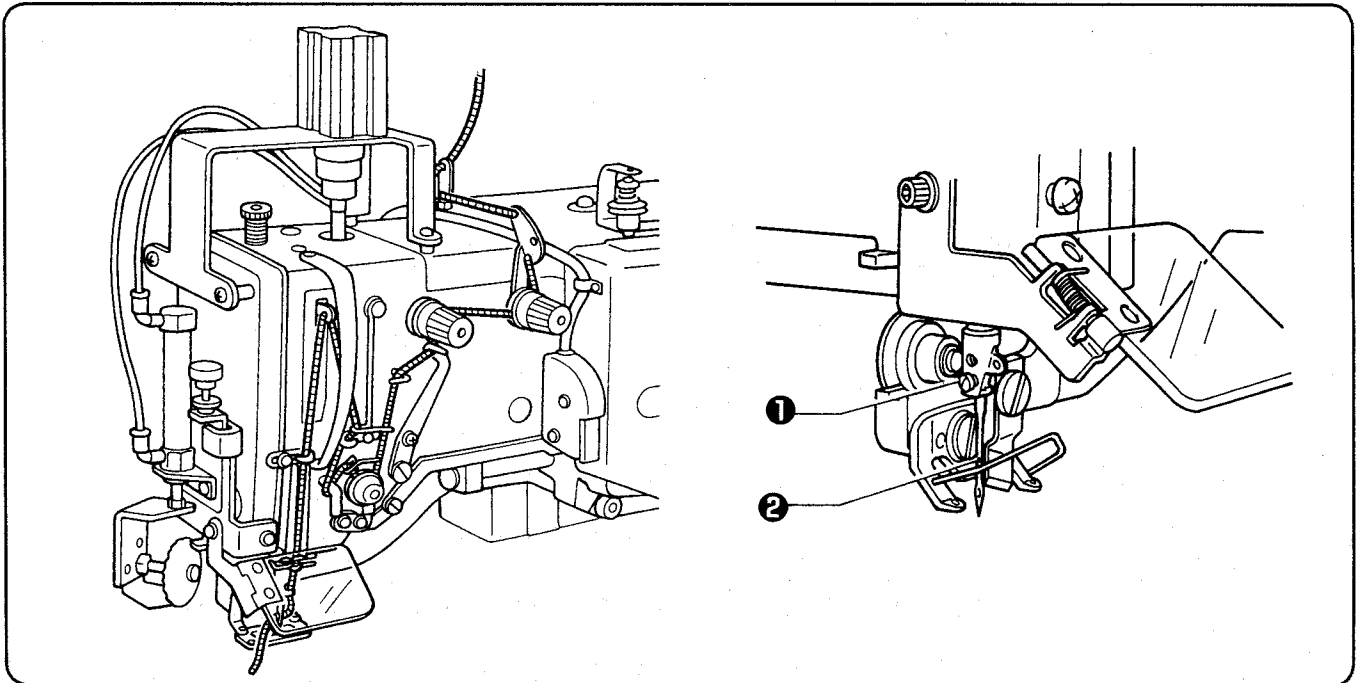

- To replace the needle, loosen screw ① in the figure above and replace the needle ②.

3-7. Lubrication

⚠ CAUTION



- Turn off the power switch before starting any cleaning work, otherwise the machine may operate if the start switch or the foot switch is pressed by mistake, which could result in injury.



- Be sure to wear protective goggles and gloves when handling the lubricating oil and grease, so that they do not get into your eyes or onto your skin, otherwise inflammation can result. Furthermore, do not drink the oil or eat the grease under any circumstances, as they can cause vomiting and diarrhoea. Keep the oil out of the reach of children.

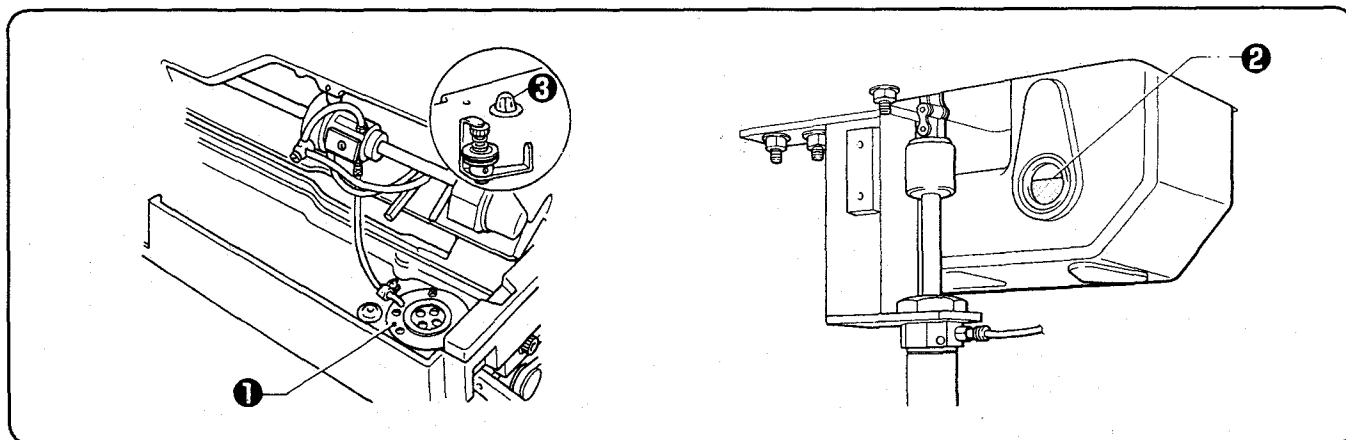

1. Tip back the sewing machine.
2. Pour the oil into the oil tank from the top of the oil filter ① until the oil level reaches the center of the oil tank sight glass ② which is under the work table.
When the oil level drops below this point, be sure to add more oil.
Start and stop the machine at least five times and check that the oil rises to the sight glass ③.

3-8. Adding oil

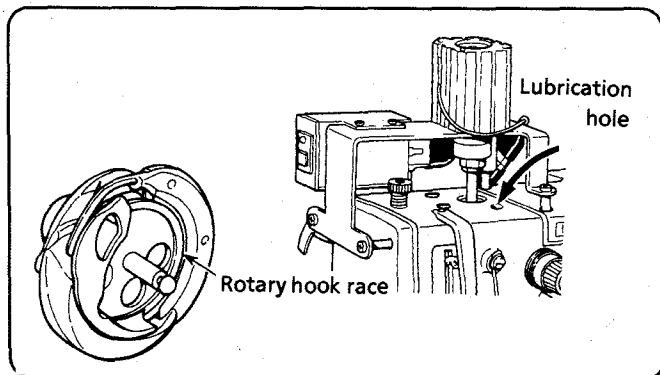

(NOTE)

- When setting up the sewing machine and when it hasn't been used for an extended period of time, be sure to add 2 - 3-drops of oil at the places indicated by arrows.

3-9. Adjusting the rotary hook lubrication amount

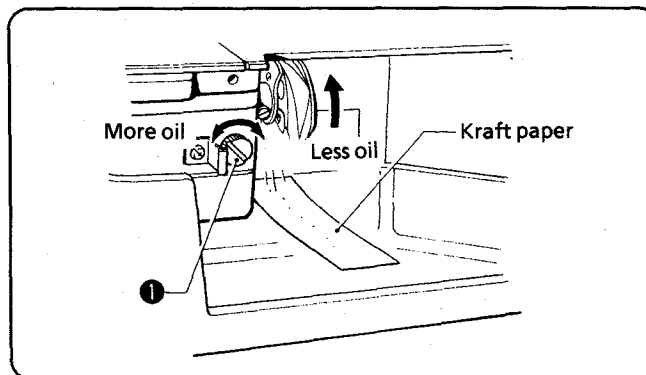

Turn the lubrication adjustment screw ① to make fine adjustments to the lubrication amount.

(The machine is factory-adjusted to spray approximately 10 drops of oil for approximately each 114 stitches sewn. Use kraft paper to check this.)

4. OPERATIONS

4-1. Explanation of the operation panel and main unit switches

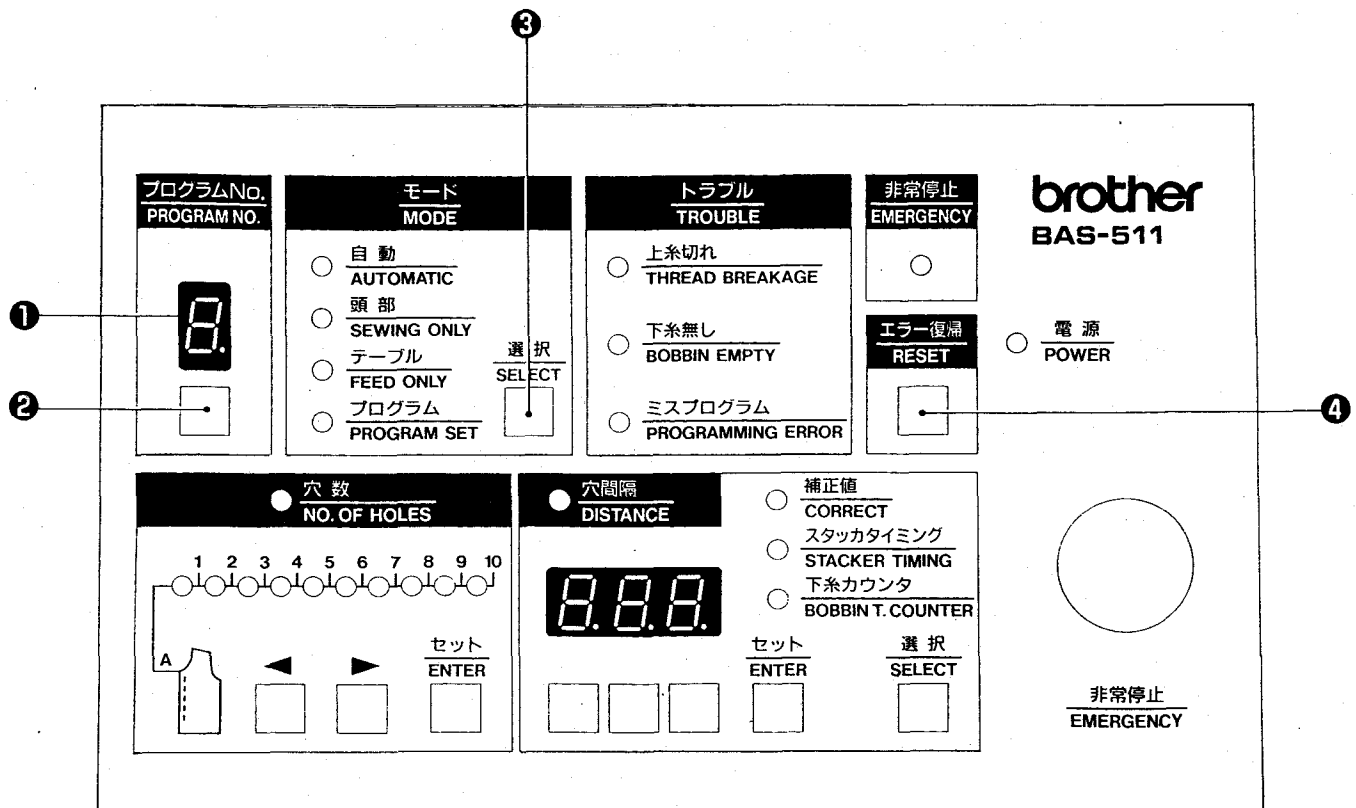

1. PROGRAM NUMBER

- Indicates the number of the currently-selected program.
- If the program number is between 10 - 19, the first digit is displayed with a decimal point.

2. Program selection switch

- This switch is used to change the program number. However, for program numbers 0 and 15 - 19, the distance between holes is always uniform, whereas for program numbers 5 - 19
- The program number is incremented by 1 each time this switch is pressed. The program number will return to 0 after 9 is selected (if DIP switch 1-2 is OFF), or after 19 is selected (if DIP switch 1-2 is ON).
- In automatic and feed only modes, this switch can be used only when material has been set.

3. MODE selector

- This switch is used to change the mode.
- The mode changes in the following order each time this switch is pressed.
 AUTOMATIC → PROGRAM SET → FEED ONLY → SEWING ONLY → AUTOMATIC ...
 [AUTOMATIC] Set here for automatic sewing.
 [SEWING ONLY] Set here for trial sewing or manual sewing.
 [FEED ONLY] Set here to operate the clamp only.
 [PROGRAM SET] Set here when programming a pattern.

4. RESET switch

- This switch is used to reset emergency stops and errors.
- It is also used to clear the clamp (L) setting position display.

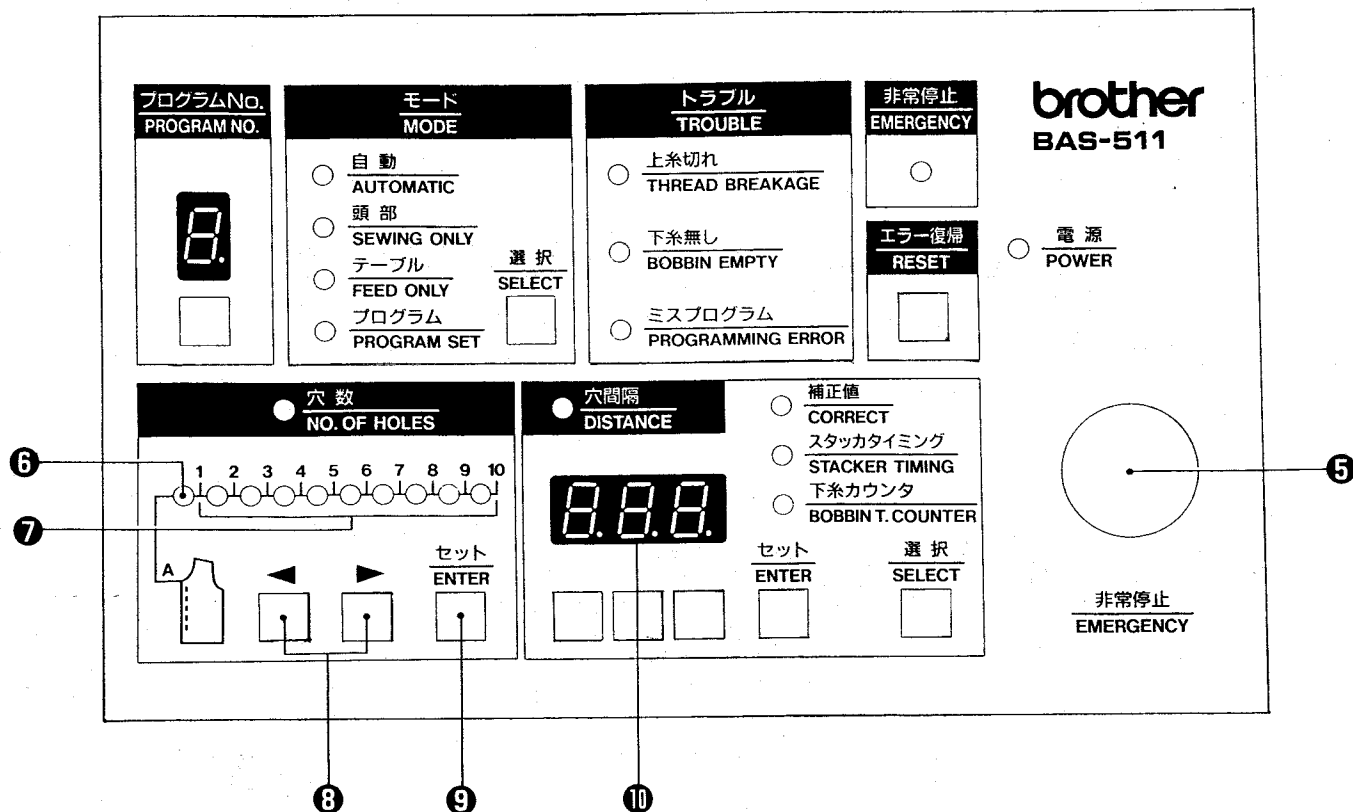

5. EMERGENCY switch

- This switch is used to make an emergency stop to automatic sewing.

6. Dimension A indicator

- When this indicator is illuminated in program set mode, distance A can be input.
- If it is illuminated in while a NO. OF HOLES indicator is illuminated, it means that 10 has been added to the indicated number of holes.

7. NUMBER OF HOLES indicators

- Indicates the number of holes (number of feeds); the current feed position is indicated with a blinking indicator (number of holes, distance).

8. Arrow buttons

- This switch is used to increase and decrease the number of holes.
- In sewing only mode, it is used to move the clamp to a easy position for carrying out test sewing.

9. NO. OF HOLES ENTER switch

- This switch is used when entering the number of holes.
- In automatic mode, it can be used to cause only the stacker to operate.

10. LED display

- This is used to show the current distance, bobbin thread counter, production counter, stacker timing and correction settings.

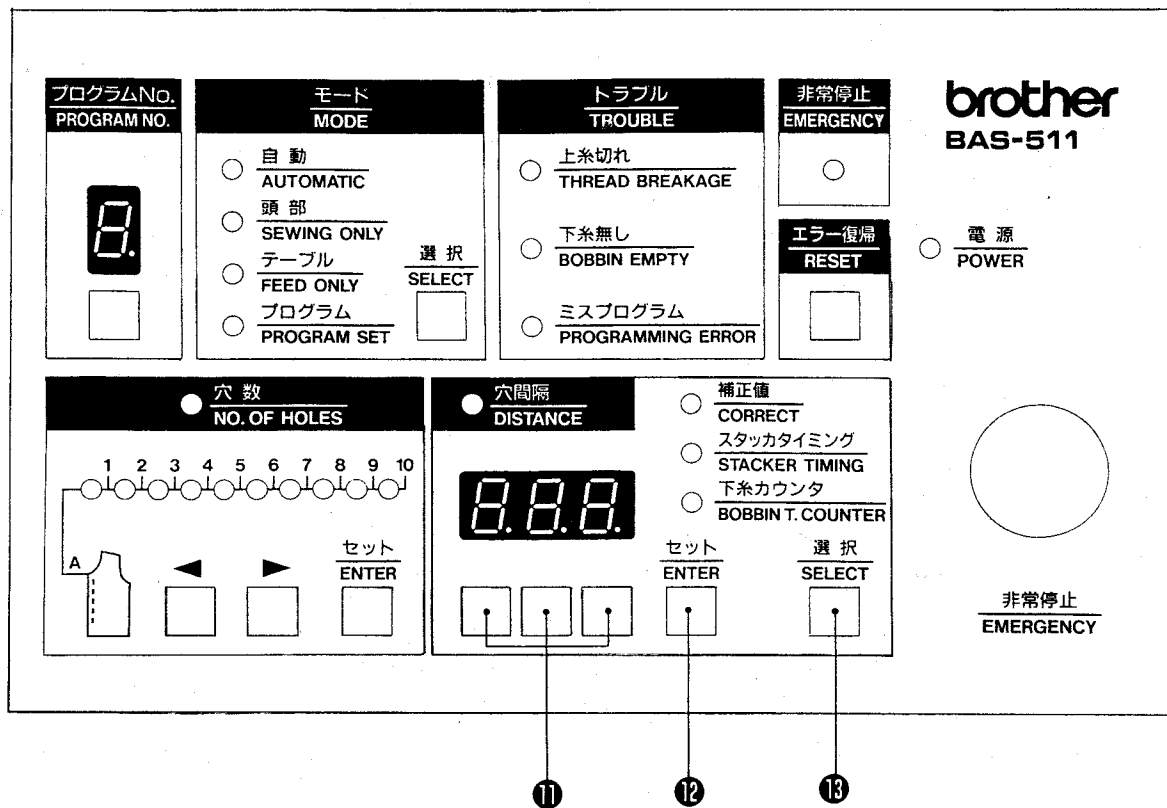

11. LED selector buttons
 - Used to change the number in the LED sidplay (distance, thread counter).
12. DISTANCE ENTER switch
 - This switch is used to accept the values input for the distance, bobbin thread counter, stacker timing and correction settings.
 - In automatic mode, it is used to display the current production counter setting.
13. SELECT switch
 - This switch is used to change the bobbin thread counter, stacker timing and correction settings. The settings which can be changed in each respective mode are indicated below.

[AUTOMATIC]	=====	thread counter, stacker timing, correction
[SEWING ONLY]	=====	thread counter
[FEED ONLY]	=====	stacker timing
[PROGRAM SET]	=====	Not possible

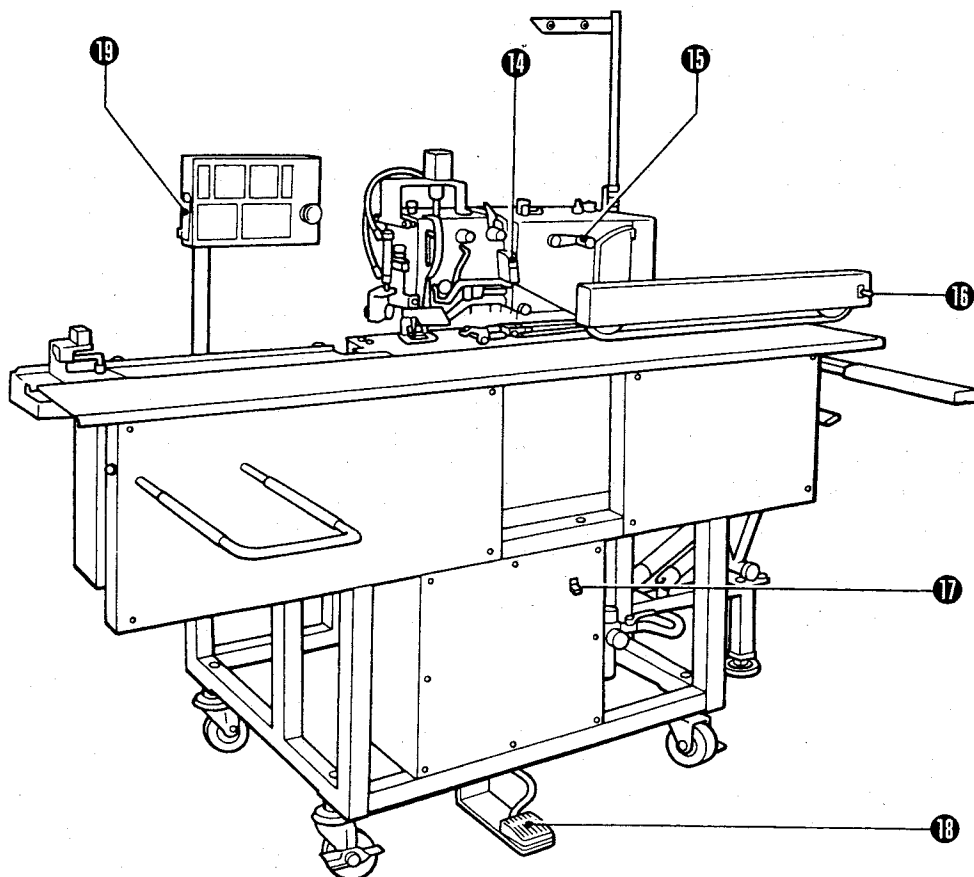

14. Start switch
 - This switch is used to assign the home position and to start sewing. In addition, during one-pedal operation (refer to page 27), it can also be used for foot switch operations.
15. Handle
 - This handle is used when you would like to manually feed the material through the sewing machine. However, if the handle is turned while the power is turned on, error E6 will be displayed.
16. Stacker switch
 - This switch is used to select whether the stacker is to operate or not.
17. Power switch
 - This switch turns the power on and off.
18. Foot switch
 - This switch is used to raise and lower the clamp and cloth presser. In addition, it is also used as the start switch during one-pedal operation.
 - It is also used to raise and lower the guider immediately after the power has been turned on.
19. Panel DIP switches
 - These switches should be set in accordance with the desired sewing conditions.

4-2. Operational set-up

1. Set panel DIP switches No.2-1 to No.2-4 ❶ to match the size of the cutter and gauge which are being used. (Refer to page 39.)
2. Set the other panel DIP switches in accordance with the desired sewing conditions. (Refer to the table below.)
3. Turn on the power switch ❷.
4. Press the start switch ❸. The clamp will move to the home position.

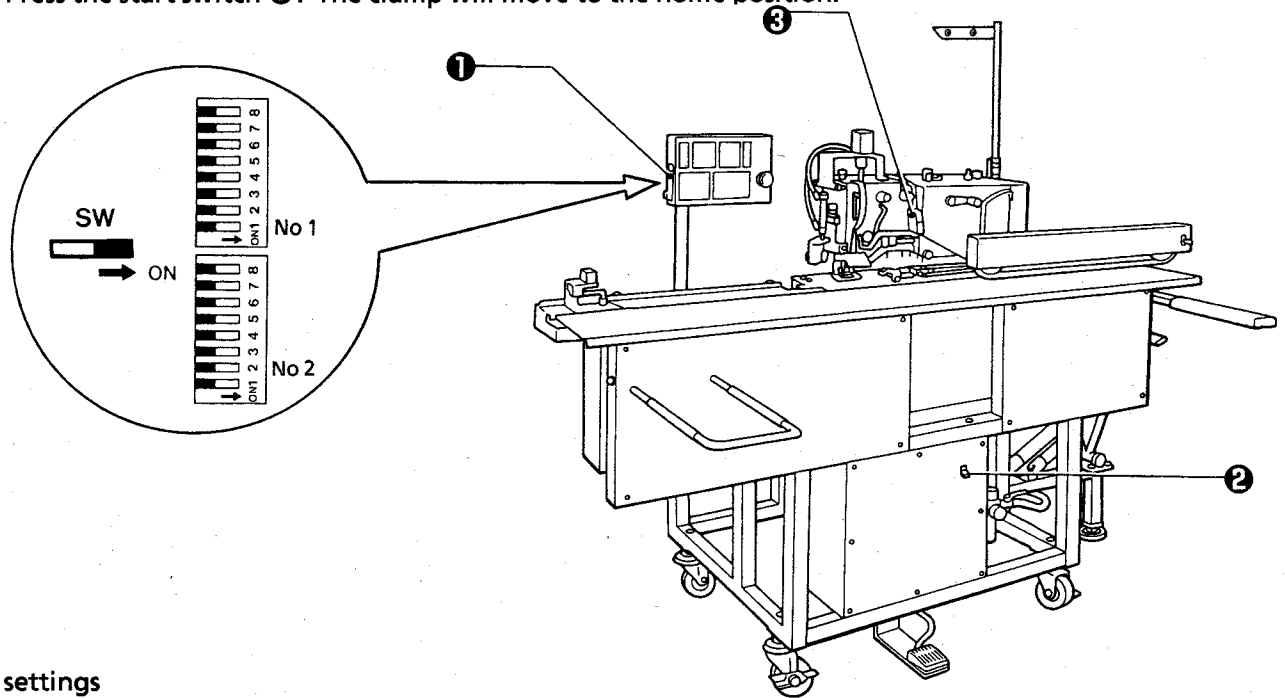

DIP settings

DIP switch No.	OFF	ON
1- 1	men's	women's
- 2	Max. 10 program numbers	Max. 20 program numbers
- 3	For AC 60-Hz power supply areas	For AC 50-Hz power supply areas
- 4	Body only specifications	Full garment specifications
- 5	Two-pedal operation	One-pedal operation
- 6	Edge guide lowering occurs later	Edge guide lowering occurs earlier
- 7	Minimum distance A for men's garments: 55 mm	Minimum distance A for men's garments: 45 mm
- 8	Normal material (Max. feed length 600 mm)	Long material (Max. feed length 1150 mm)
2- 1 - 2 - 3 - 4	Gauge and cutter size selection	
- 5	Servo feed setting OFF ON OFF ON OFF ON OFF ON OFF OFF ON ON OFF OFF ON ON OFF OFF OFF OFF ON ON ON ON	
- 6	Decrease \longrightarrow Increase	
- 7		
- 8		Stacker motor automatically operates when power turned on

NOTE: The power of the machine should be turned off before changing switch.
 If the power is not turned off, functions do not change.

4-3. Inputting programs

4-3-1. Inputting a program for sewing regular-interval buttonholes

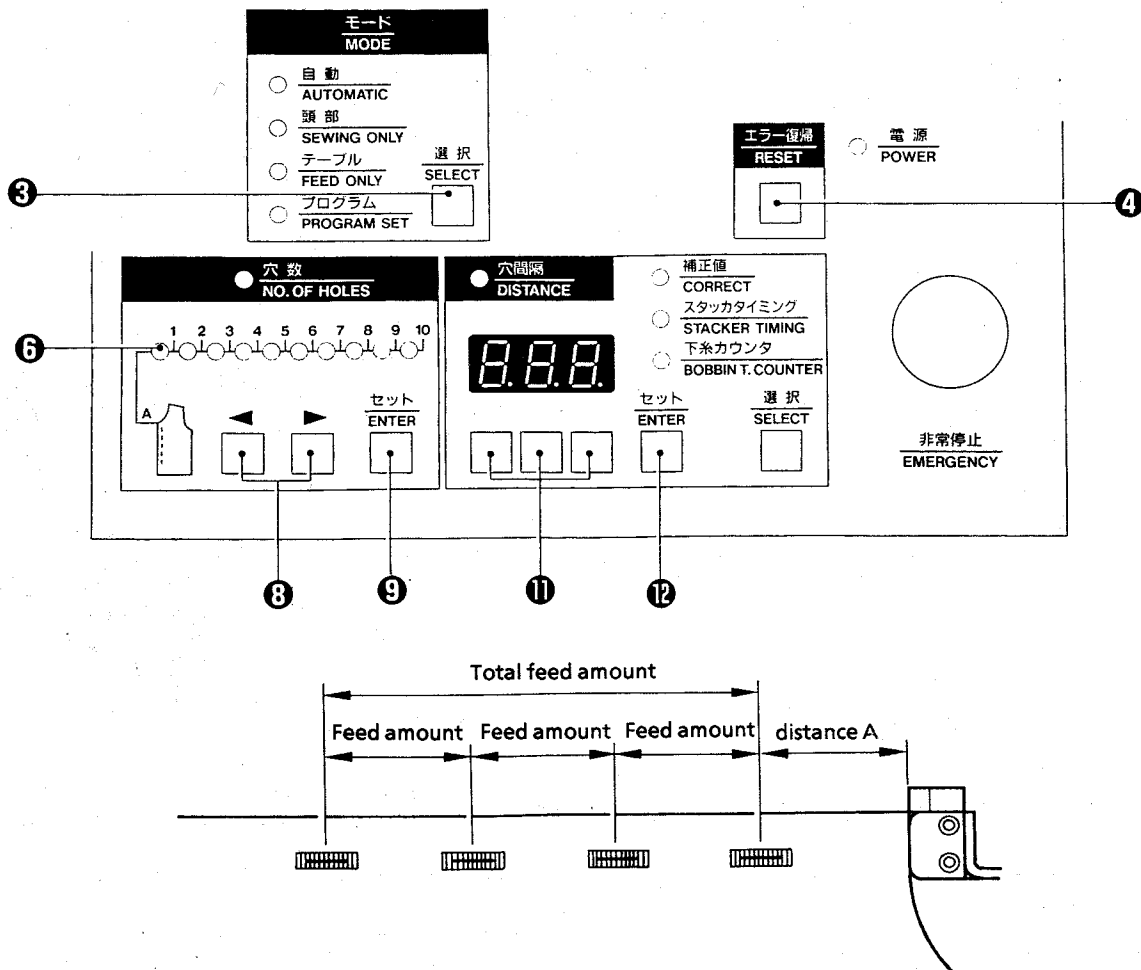

- Set the mode to AUTOMATIC or FEED ONLY, and then set to program number to either 0 or to between 15 - 19.
- Set MODE selector to PROGRAM SET.
The dimension A indicator ⑤ will light and the distance indicator will blink.
- Press the LED display setting switches ⑪ to set distance A.
(NOTE) This step can be omitted if you are not going to change distance A.
- Press the DISTANCE ENTER switch ⑫.
The DISTANCE indicator will start flashing.
(NOTE) If the distance is set to a value which is not within 55 - 399 mm (45 - 389 mm when the minimum distance A for men's garments has been set to 45 mm and when sewing ladies' garments), the PROGRAMMING ERROR indicator will illuminate. Press the RESET switch ④ to clear the error, and then repeat the setting procedure from step 3.
- Press arrow switches ③ to enter the number of holes.
Press ▶ ③ to increase, ◀ ③ to decrease the number.
The number of buttonholes will be indicated by the number that becomes on above the display. The number of indicators that light shows the number of feed intervals.
(NOTE) If the number of holes set is 11 or greater, the distance A indicator ⑤ will illuminate to show that the number of holes is 10 more than the indicated number.
- Press the NO. OF HOLES ENTER switch ⑨. (This will accept the number of holes setting.)
The DISTANCE indicator and the "1 - 2" number of holes indicator will start flashing.
- Press the LED display setting switches ⑪ to set the feed amount.

8. Press the DISTANCE ENTER switch ⑫. (This will accept the distance setting.)
The CORRECT indicator will start flashing.
9. Press the LED display setting switches ⑪ to set the correction amount. (Refer to page 15.)
10. Press the DISTANCE ENTER switch ⑫. (The new program will then be written to memory.)
The machine will then return to the stage where distance A can be entered (step 2.).



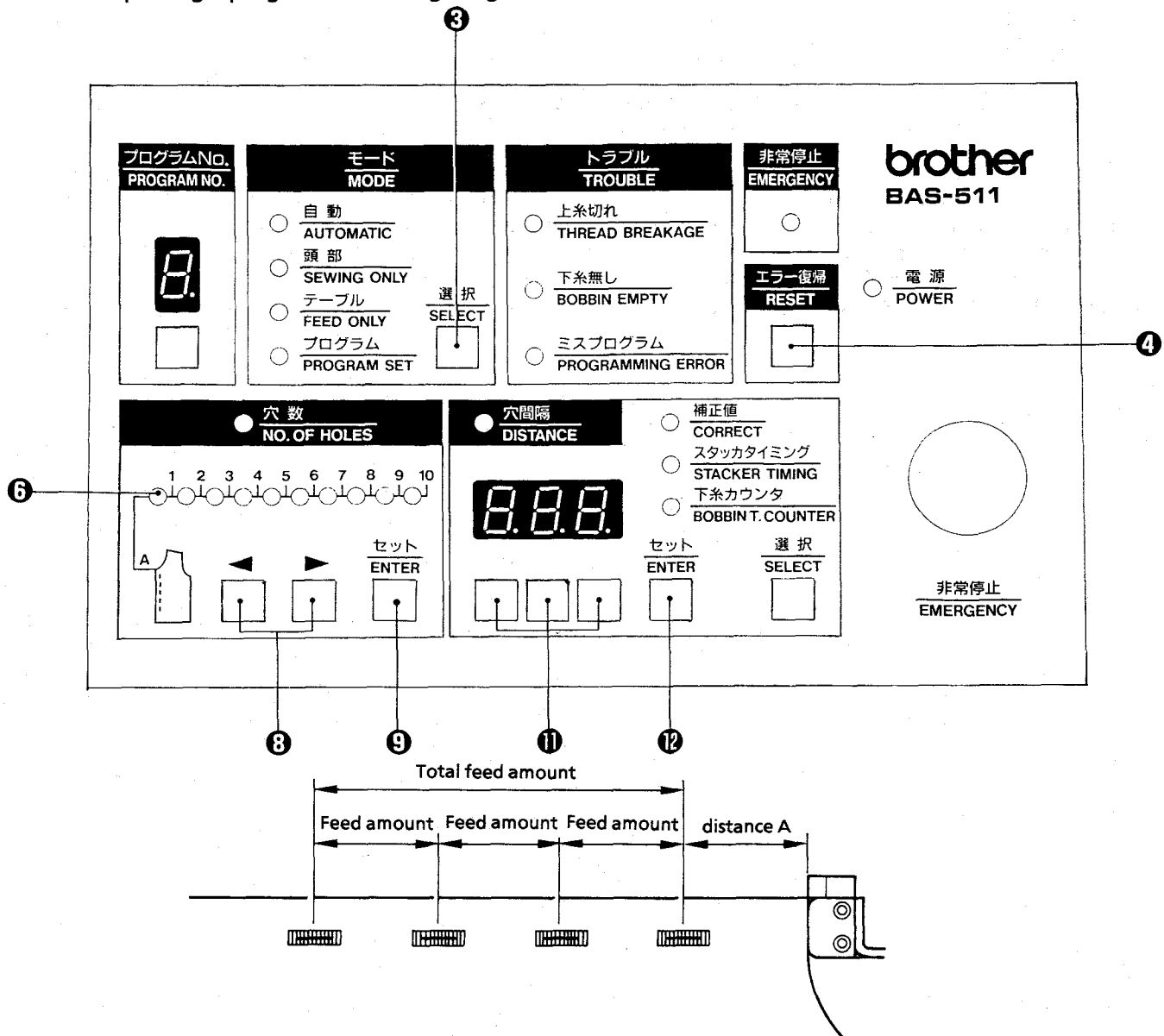

(NOTE)

- If a feed amount that exceeds 600 mm is set, or if the total of distance A + the total feed amount is not between 205 - 655 mm (195 - 645 mm when the minimum distance A for men's garments has been set to 45 mm and when sewing ladies' garments), the PROGRAMMING ERROR indicator will illuminate. Press the RESET switch ④ to clear the error, and then repeat the setting procedure from step 3.
- If the MODE switch ③ is pressed during programming, the mode will be switched to feed only mode.



4-3-2. Inputting a program for sewing irregular-interval buttonholes



1. Set the mode to AUTOMATIC or FEED ONLY, and then set to program number to between 1 - 14.
2. Set the MODE selector ③ to PROGRAM SET.
The dimension A indicator ⑥ will light and the distance indicator will blink.
The NUMBER OF HOLES indicator will blink.
3. Press the LED display setting switches ⑪ to set distance A.
(NOTE) This step can be omitted if you are not going to change distance A.
4. Press the DISTANCE ENTER switch ⑫. (This will accept the distance A setting.)
(NOTE) If the distance is set to a value which is not within 45 - 399 mm, the PROGRAMMING ERROR indicator will illuminate. Press the RESET switch ④ to clear the error, and then repeat the setting procedure from step 3.
5. Press the arrow buttons ③ to set the number of buttonhole stitches.
When the ◀ arrow switch ③ is pressed, the stitch number setting increases, and when the ▶ arrow switch ③ is pressed, the stitch number setting decreases.
The number which is illuminated at the upper right indicates the number of buttonhole stitches, and the number at the upper left indicates the feed amount.
* If the number of holes set is 11 or greater, the distance A indicator ⑥ will illuminate to show that the number of holes is 10 more than the indicated number.

6. Press ENTER  to store the number of holes.
The NUMBER OF HOLES indicator will light steady, and the DISTANCE indicator and the indicator for the gap between holes 1-2 will blink.
7. Press the LED display setting switches  to set the feed amount to between 1 - 2.
8. Press ENTER . (The position of the second buttonhole is now set.)
The DISTANCE indicator and the "2 - 3" number of holes indicator will start flashing.
9. Continue programming by repeating steps 7 and 8 for the number of feed steps.
After the setting for the last hole has been made, the CORRECT indicator will start flashing.
10. Press the LED display setting switches  to set the correction amount.
11. Press the DISTANCE ENTER switch . (The new program will then be written to memory.)
The machine will then return to the stage where distance A can be entered (step 2.).

(NOTE)

- If a feed amount that exceeds 600 mm is set, or if the total of distance A + the total feed amount is not between 150 - 645 mm, the PROGRAMMING ERROR indicator will illuminate. Press the RESET switch  to clear the error, and then repeat the setting procedure from step 3.
- If the MODE switch  is pressed during programming, the mode will be switched to feed only mode.

4-4. Table feed

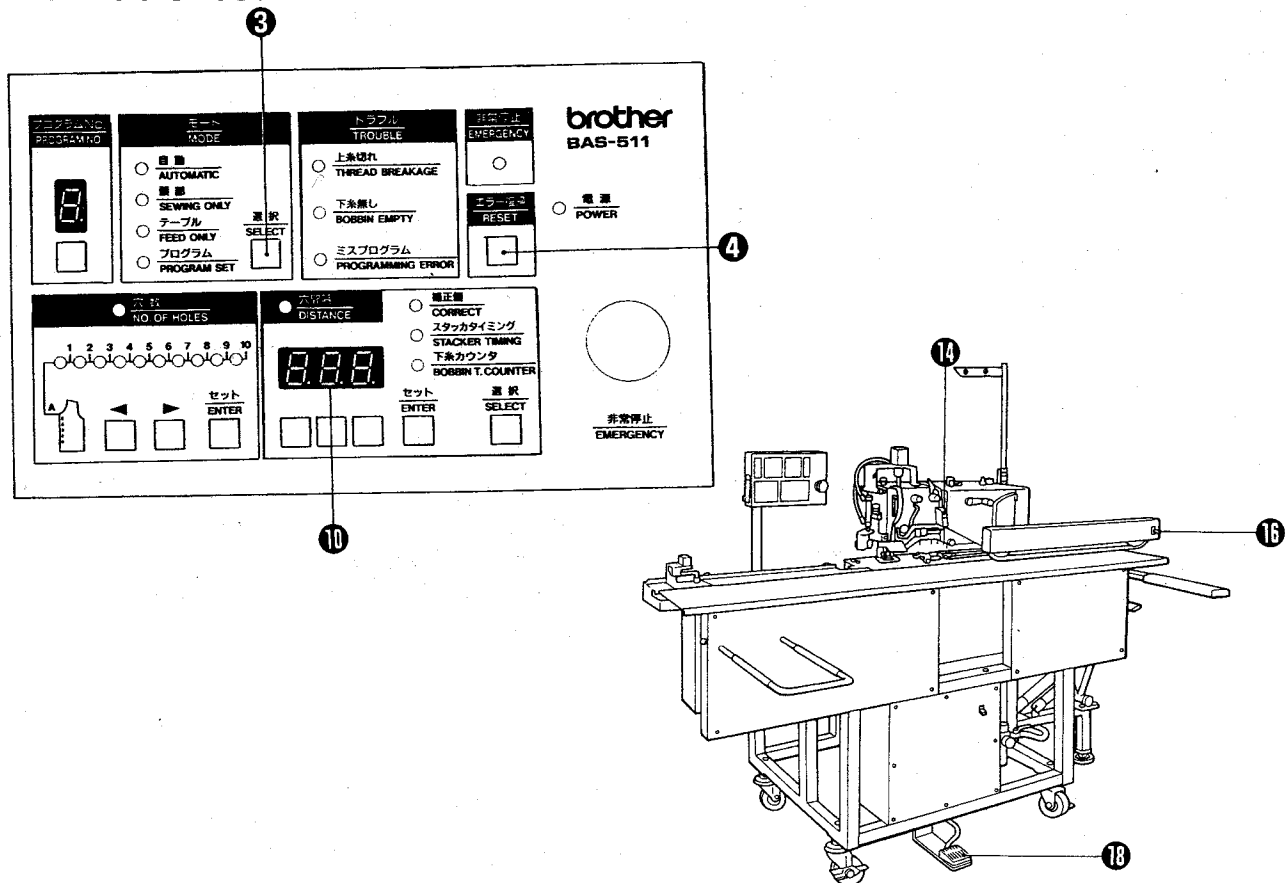

4-4-1. Checking clamp movement and stacker operation

1. Press the MODE switch ③ to switch the mode to feed only mode.
2. Turn on the stacker switch ⑮.

For men's garments, the clamps will move and stop at or to the left of the position indicated by the number on the LED display ⑩. For ladies' garments, they will stop at the position indicated by the number on the LED display ⑩.
3. Loosen the clamp (L) screws and move the clamp to the position which is furthest away from the machine. Tighten the screws again at that position.

(NOTE) Refer to "4-13. Setting clamp (L)" on page 34 for details on determining the clamp position.

For both men's and ladies' garments, do not secure clamp (L) in a position that is to the right of the position indicated by the number on the LED display.
4. Press the RESET switch ④. The display will change to show the stacker timing.
5. Place the material underneath the cloth presser in the correct position, and then depress the foot switch ⑰. Clamp (L) and clamp (R) will be lowered and the material will be clamped.

(NOTE) If you would like to adjust the position of the material, depress the foot switch ⑰ once more. The clamps will then be raised.
6. Press start switch ⑭.

The LED display ⑩ will switch from the stacker timing to show the hole distance.
7. Press start switch ⑭.

The clamps will move to the right only by the feed amount for the buttonhole distance.
8. Press the start switch ⑭ until the clamps move to the final feed position (the position where all of the NO. OF HOLES indicators are turned off).
9. Press start switch ⑭.

The clamps will move to the first buttonhole position (material setting position) and the stacker will operate.
10. Set stacker switch ⑮ to OFF to remove the material.

(NOTE)

- If checking the clamp movement when the stacker switch ⑩ is turned off and the clamps return to the material setting position, the edge guide may drop down and clamp the material. If this happens, press the MODE switch ⑤ to switch to sewing only mode. This will cause the edge guide to be raised so that the material can then be removed. (The same thing can happen during automatic sewing.)
- If you would like to change the stacker presser position, refer to "Adjusting the stacker timing" on page 36.

4-4-2. Moving the clamp to the desired position and sewing

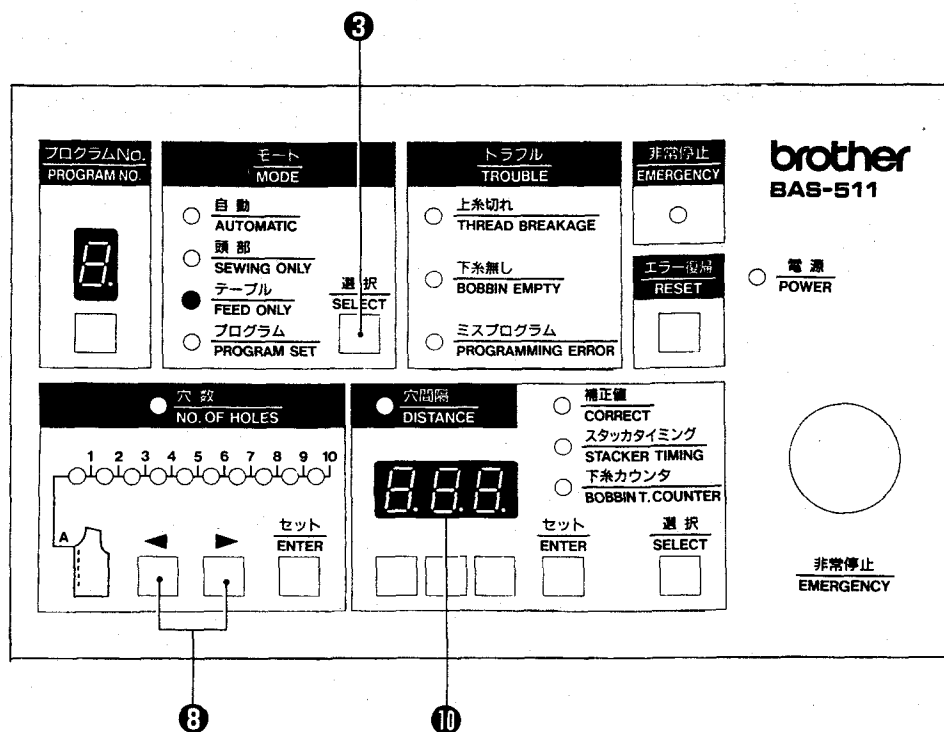

1. Set the MODE selector ③ to FEED ONLY.
2. Place the material underneath the cloth presser in the correct position.
3. Press foot switch ⑧ and set the material.
(NOTE) If you would like to adjust the position of the material, depress the foot switch ⑧ once more.
The clamps will then be raised.
4. Press the start switch ⑭.
The LED display ⑩ will switch from the stacker timing to show the hole distance.
5. Press the start switch ⑭ to move the clamps to the next position for sewing.

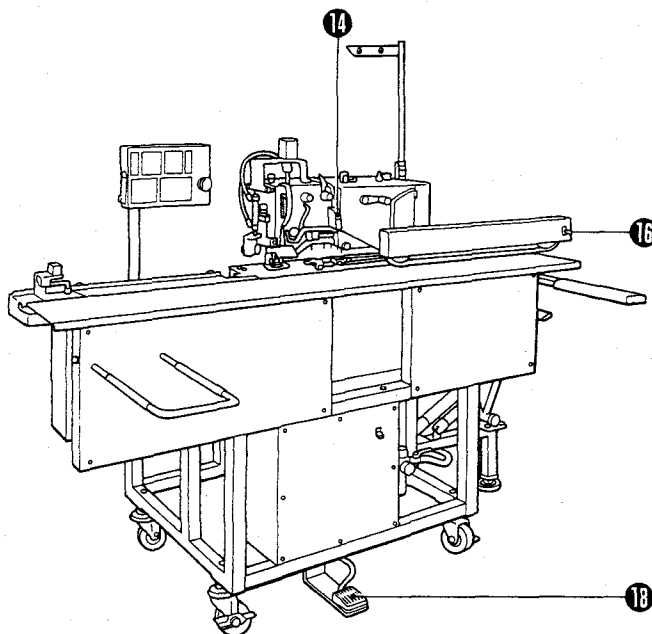

6. Press the MODE switch ③.
The FEED ONLY indicator will illuminate and the SEWING ONLY indicator will flash, and the machine will switch to the sewing standby condition.
7. Press the start switch ⑭. One buttonhole will then be sewn.
The cloth presser can be raised and lowered at this time by depressing the foot switch ⑮.
If the start switch ⑭ is pressed once more, the clamps will move to the next buttonhole sewing position.
From then on, the machine will alternately sew one buttonhole and move the clamps each time the start switch ⑭ is pressed.
8. Press the MODE switch ③.
The AUTOMATIC indicator will illuminate and the machine will switch to automatic mode.
If the start switch ⑭ is pressed at this time, subsequent sewing operations will be carried out automatically.
9. If the MODE switch ③ is pressed in step 8 above instead of the start switch ⑭, the FEED ONLY indicator will illuminate and the machine will switch once more to feed only mode (the same condition as in step 5).
10. After this, keep pressing the start switch ⑭ until the last buttonhole is sewn.
11. Press the start switch ⑭.
If the stacker switch ⑯ is on, stacking will be carried out and the clamps will then move back to the first buttonhole position (material setting position).
If the stacker switch ⑯ is off, the clamps will move to the material setting position without stacking being carried out.

4-5. Trial sewing

1. Set the MODE selector ③ to SEWING ONLY.
2. Press ► ③ to move the clamp to an easier sewing position.
(NOTE) To return to the home position, set MODE selector ③ to any position other than SEWING ONLY.
3. If the material is placed underneath the cloth presser and the start switch ⑭ is pressed, one buttonhole will be sewn.
The cloth presser can be raised and lowered at this time by depressing the foot switch ⑮.

4-6. Setting a workpiece

Turn the power switch on. The material clamp will rise.

Set the men's/women's garment type selector ❶ as desired.

Press the start switch. Clamp L ❷ will move left, and will then return to the programmed position.

(NOTE)

- See page 5 for the programming guidelines and page 4 for switching between men's and women's garments.

(Men's garments) Set DIP switch No.1-1 on the operation panel to ON, and then turn on the power.

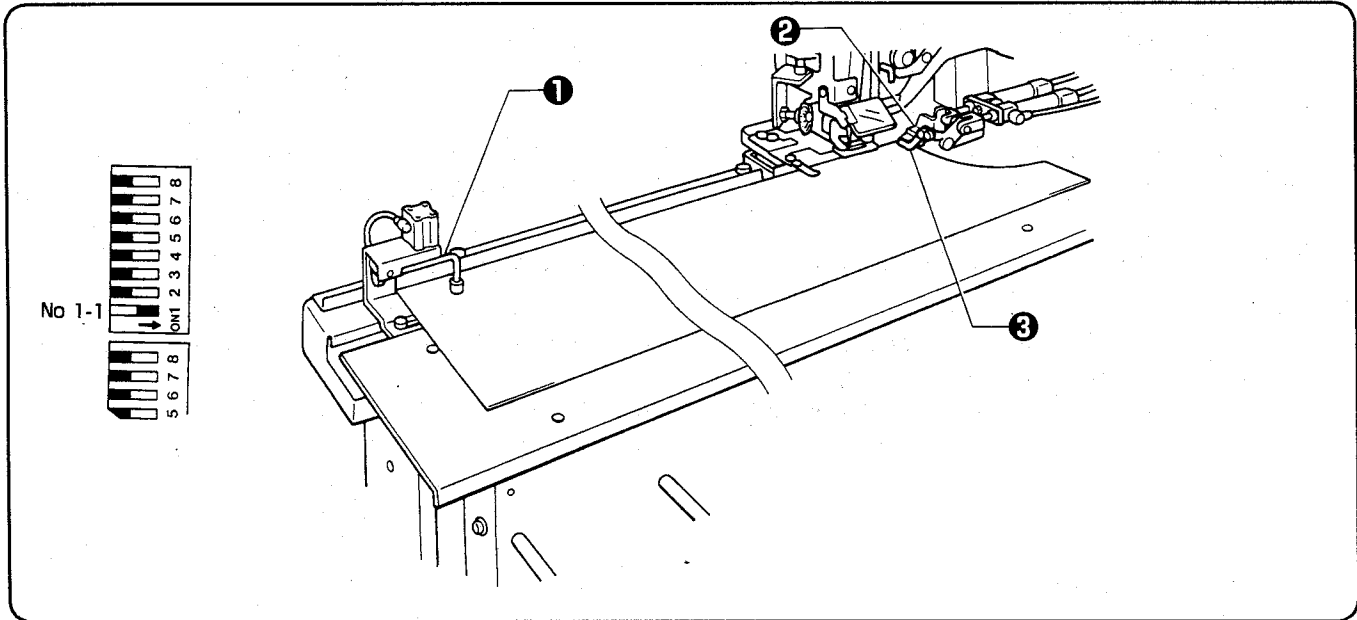

Align the material with the leading edge guide ❶, and then press the foot switch. Clamps L ❷ and R ❸ will hold the material.

If clamp adjustment is required, refer to the below.

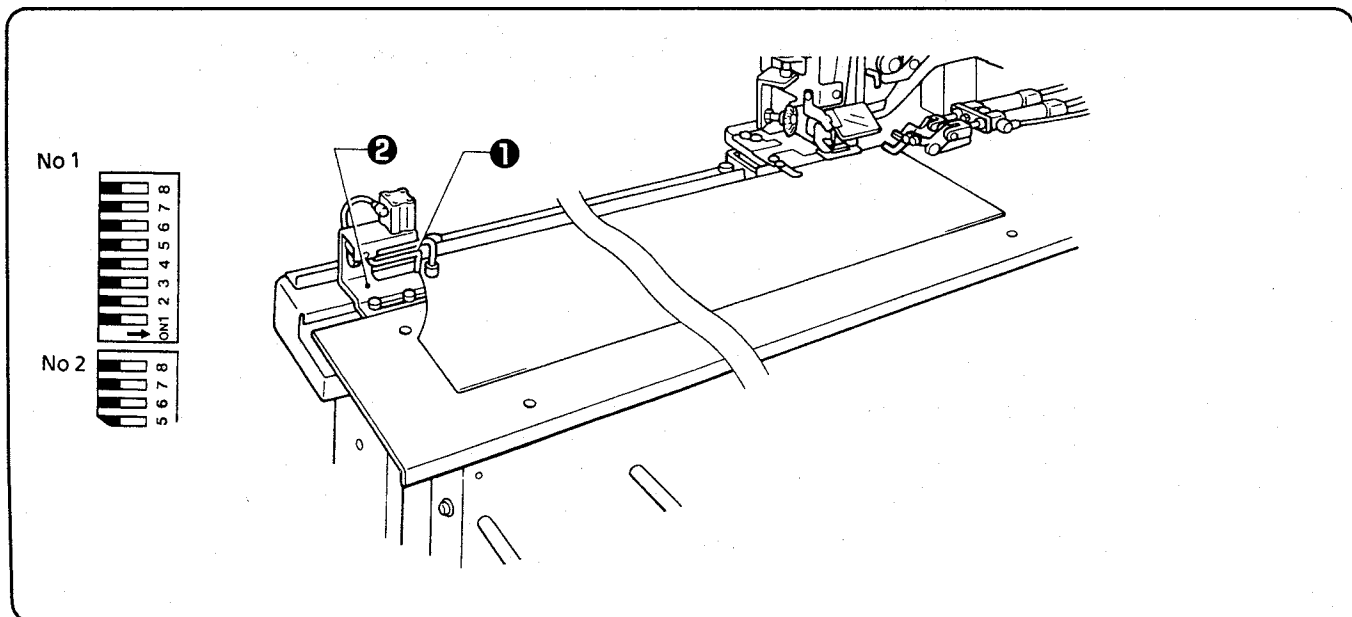

(Ladies' garments) Set DIP switch No.1-1 on the operation panel to OFF, and then turn on the power.



Install the ladies' garment guide ❷ to the clamp (L) support plate ❸ with the two screws ❶ so that it is aligned with the reference line.

4-7. Adjusting

⚠ CAUTION

- 
 • Maintenance and inspection of the sewing machine should only be carried out by a qualified technician.
- 
 • Turn off the power switch and disconnect the power cord from the wall outlet at the following times, otherwise the machine may operate if the start switch or the foot switch is pressed by mistake, which could result in injury.
 - When carrying out inspection, adjustment and maintenance
 - When replacing consumable parts such as the rotary hook and knife
- 
 • If the power switch and air need to be left on when carrying out some adjustment, be extremely careful to observe all safety precautions.

4-7-1. Margin-to-seam width adjustment

- The margin-to-seam width should be adjusted so that the distance from the center of the buttonhole to the material edge is from 7 to 20 mm.
- Turn the power switch off before making the adjustment.

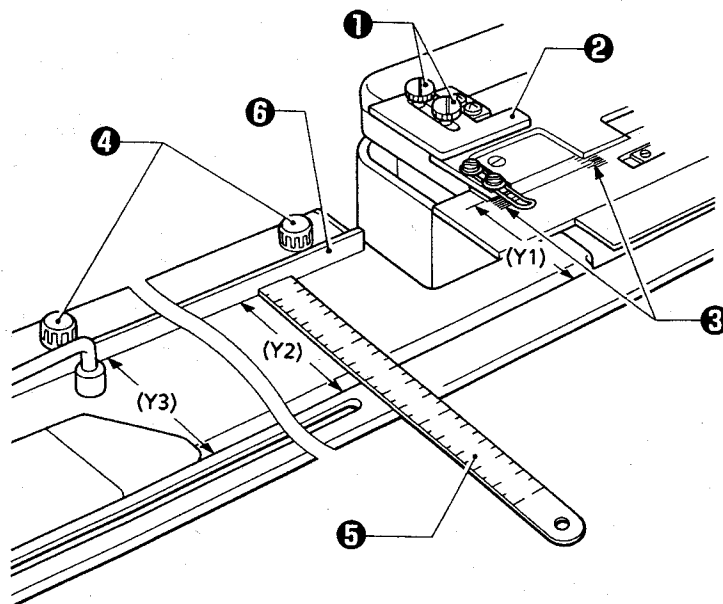

1. Loosen the two screws ①.
2. Align the vertical ruler ② with the sewing margin scale ③.
3. After setting the sewing margin, securely tighten the two screws ①.
(NOTE)
 - Be careful to ensure that the ruler ② remains straight at this time.
4. Loosen the screw ④.
5. Measure the distance Y1 with a steel ruler ⑤.
6. Set the body guide ⑥ so that Y1 = Y2 = Y3.
7. Securely tighten the screw ④.

4-7-2. Adjusting the guider.

1. Turn on the power switch.
2. Place the front of the material under the weaving pattern brush ❶.
3. Depress the foot switch. The weaving pattern brush ❶ will be lowered.
* If the foot switch is pressed once more, the weaving pattern brush ❶ will be raised.
4. While the weaving pattern brush ❶ is lowered, pull the material to the right.
Check that the material is not caught in any way and that the weaving pattern brush ❶ turns smoothly at this time.

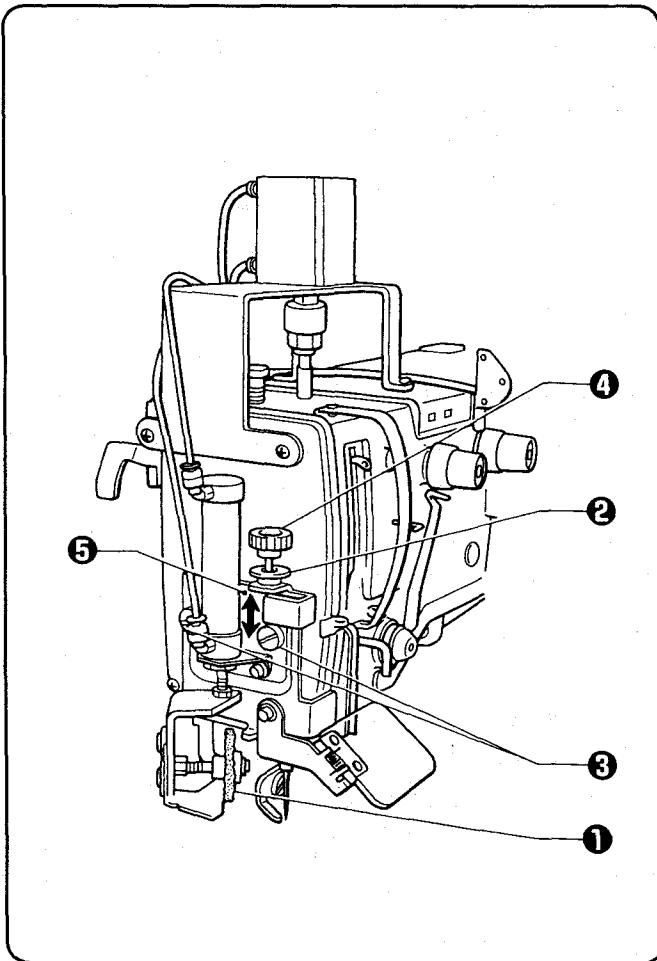

[Adjustment if the material is caught]

1. Loosen the pre-tension nut ❷.
2. Loosen the two shoulder screws ❸.
3. Turn the mini knob ❹ clockwise.
4. Move the cylinder bracket ❺ vertically to adjust the height so that the material does not get caught and so that the weaving pattern brush ❶ turns smoothly.
5. Tighten the pre-tension nut ❷.
6. Securely tighten the two shoulder screws ❸.
7. Switch the machine to feed only mode (refer to page 16) and move the material to check that it does move smoothly.

[Adjustment if the weaving pattern brush does not turn smoothly]

1. Loosen the pre-tension nut ❷.
2. Loosen the two shoulder screws ❸.
3. Turn the mini knob ❹ clockwise.
4. Move the cylinder bracket ❺ vertically to adjust the height so that the material does not get caught and so that the weaving pattern brush ❶ turns smoothly.
5. Tighten the pre-tension nut ❷.
6. Securely tighten the two shoulder screws ❸.
7. Switch the machine to feed only mode (refer to page 16) and move the material to check that it does move smoothly.

5. After adjustment is complete, press the start switch. The home position will then be assigned.

4-7-3. Tilting the machine head

1. Turn the power off.
2. Loosen the screws ② of clamp (L) ① and move the clamp to the position which is furthest away from the machine. Tighten the screws to secure clamp (L) ① in that position.
3. Move the feed mechanism by hand to a position where clamp (L) ① and clamp (R) ③ will not interfere with the machine head ④.
4. Remove the screw ⑤, and then remove the rear body support ⑥.
5. Move belt cover ⑦ in the direction of the arrow to remove.
6. Tilt the head.





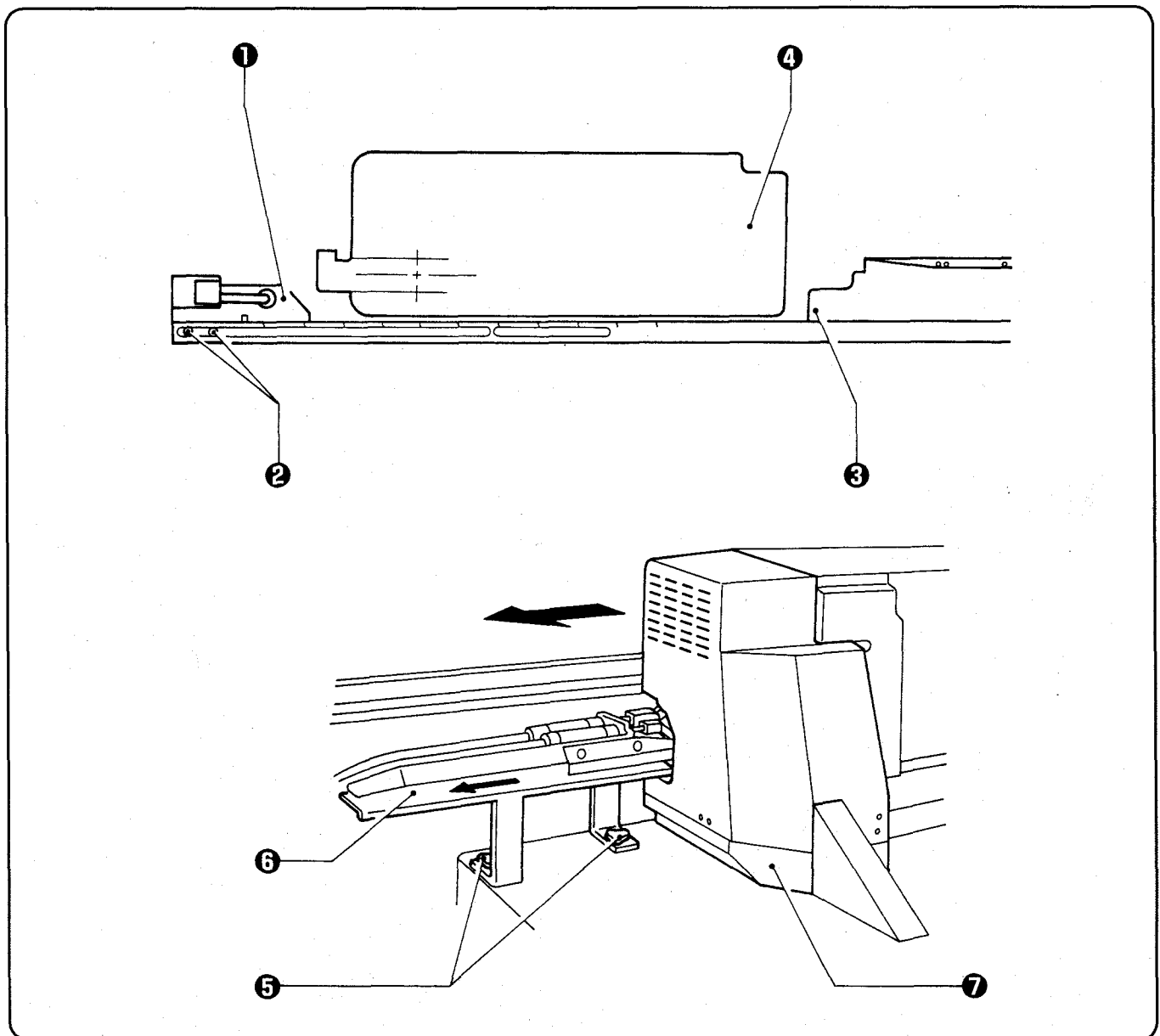

(NOTE)

- Be sure to replace clamp (L) after returning the machine head to its original position.



4-8. Sewing

⚠ CAUTION

- 
 • This sewing machine should only be used by operators who have received the necessary training in safe use beforehand.
- 
 • The sewing machine should not be used for any applications other than sewing.
- 
 • Attach all safety devices before using the sewing machine. If the machine is used without these devices attached, injury may result.
- 
 • Turn off the power switch at the following times, otherwise the machine may operate if the start switch or the foot switch is pressed by mistake, which could result in injury.
- 
 • Do not touch any of the moving parts or press any objects against the machine while sewing, as this may result in personal injury or damage to the machine.
- 
 • If an error occurs in machine operation, or if abnormal noises or smells are noticed, immediately turn off the power switch. Then contact your nearest Brother dealer or a qualified technician.
- 
 • If the machine develops a problem, contact your nearest Brother dealer or a qualified technician.

4-8-1. Standard sewing

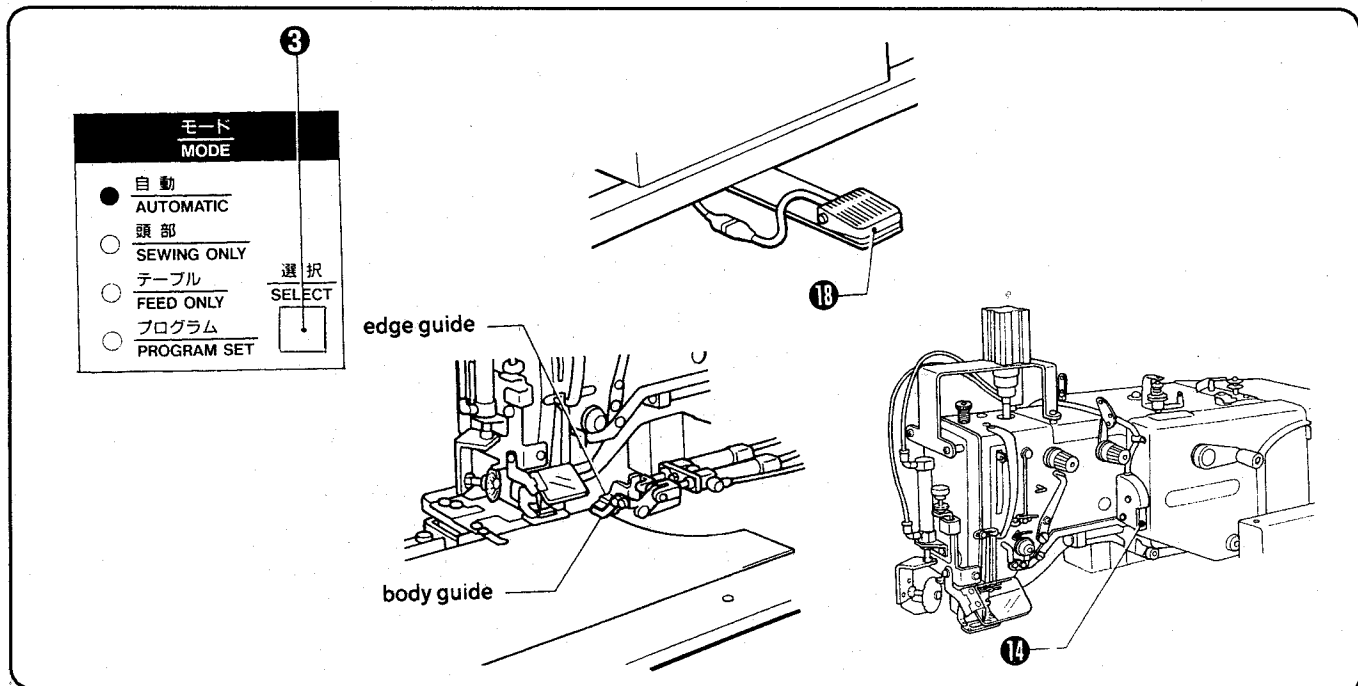

1. Set MODE selector ③ to AUTOMATIC. Set the position of clamp (L) (Refer to page 34).
 2. Align the material with the material positioning guide and bodice guide, and under the material clamp.
 3. Press the foot switch ⑱ to set the material.
 4. Press the start switch ⑭.
- The programmed buttonhole(s) will be sewn automatically.

- Women's garments

When sewing women's garments, set the material in the position opposite to that used when sewing men's garments. (The edge guide should be raised.)

Note also that the standard position of the buttonhole at dimension A is different for men's and women's garments.

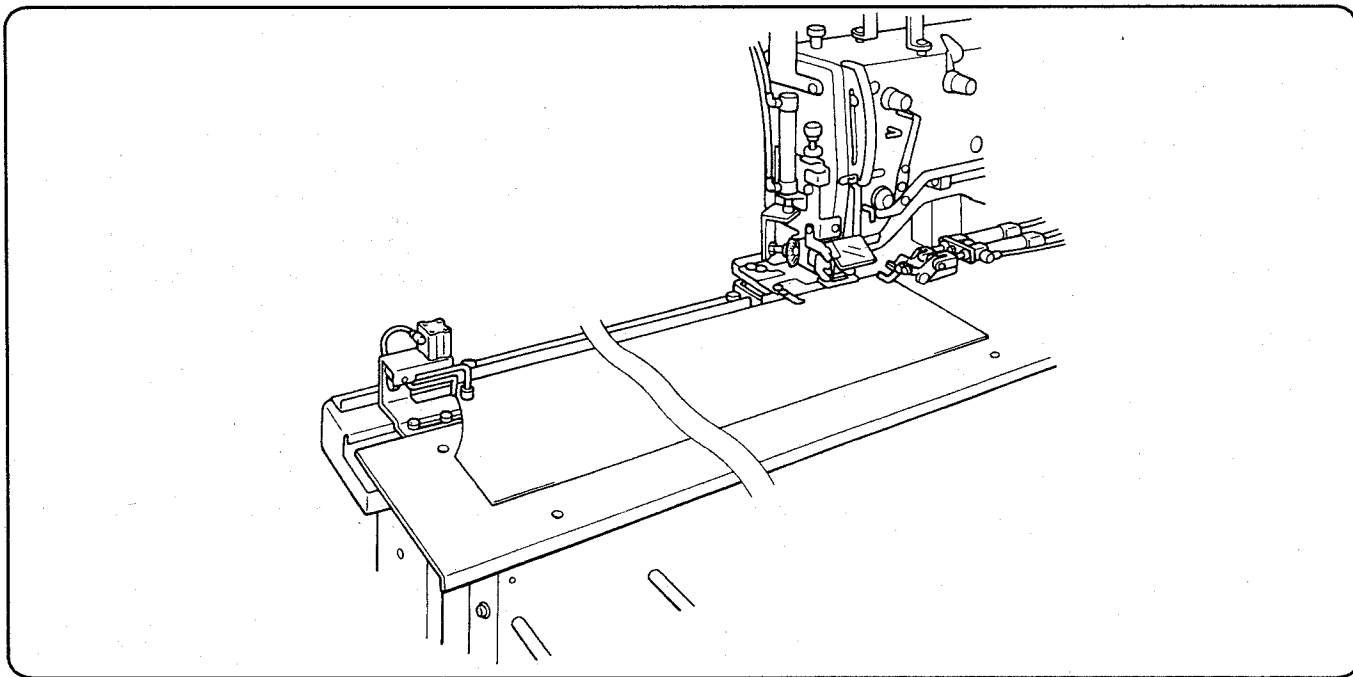

4-8-2. When using the sub-table set or table set

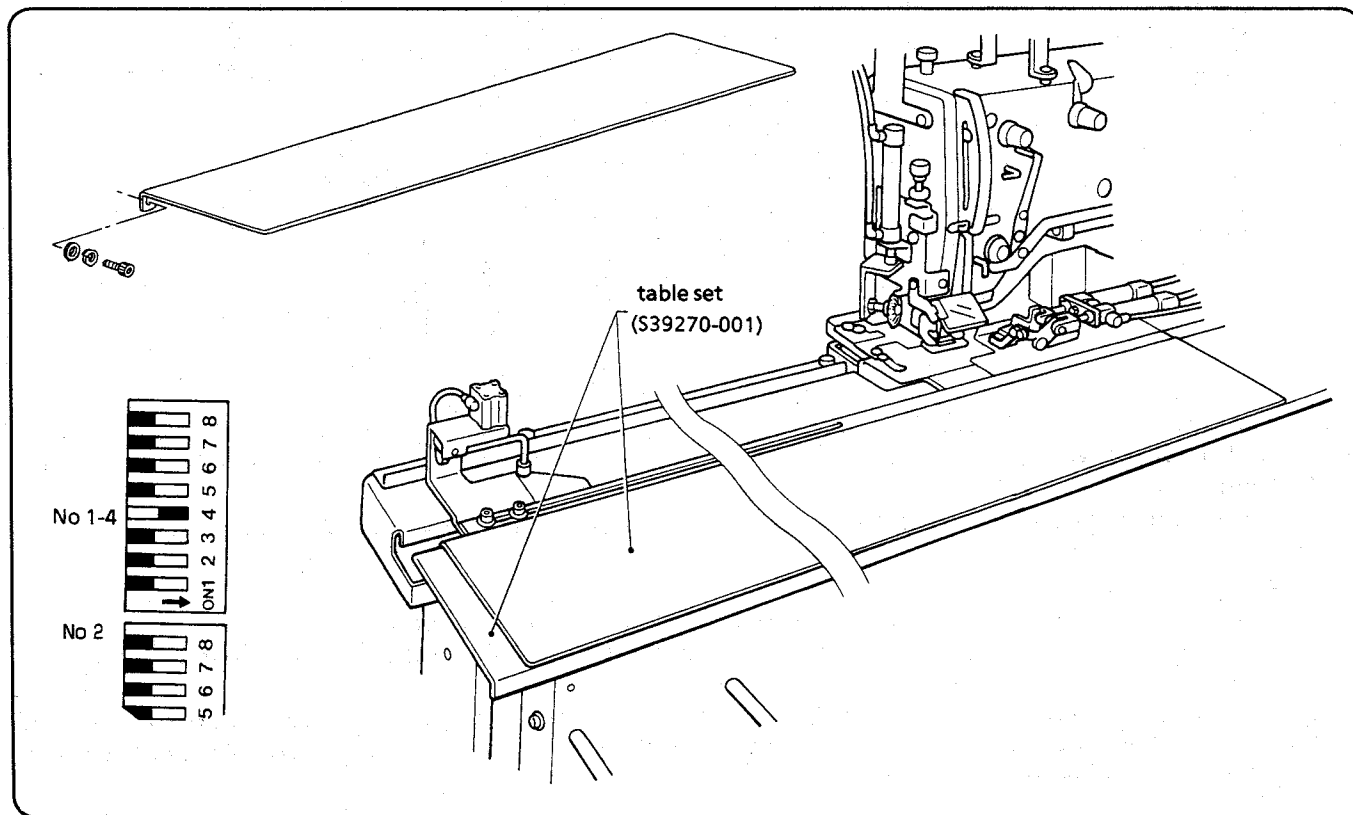

If using the optional sub-table set or table set, set DIP switch 1-4 on the operation panel to ON.

For body feed (when DIP switch No.1-4 on the operation panel is set to OFF), the clamps will return to the home position while the last buttonhole is being sewn. However, for table feed, the clamps will not move back until sewing of the last buttonhole is completed.

4-8-3. Setting servo feed

When sewing in automatic mode, the movement of the clamps which are holding the material is synchronized with the movement of the upper clamping foot. It is necessary to make the setting which matches the sewing conditions at this time.

- If feed is not keeping up
Change the servo feed setting to a stronger feed setting.
- If vibration occurs during feeding
Change the servo feed setting to a weaker feed setting.

panel DIP switch	2-5	OFF	ON	OFF	ON	* OFF	ON	OFF	ON
	2-6	OFF	OFF	ON	ON	OFF	OFF	ON	ON
	2-7	OFF	OFF	OFF	OFF	ON	ON	ON	ON
setting servo feed	decrease $\xrightarrow{\hspace{10em}}$ increase								

(NOTE)

- Turn the power switch off before resetting DIP switch 2.
- The DIP switch settings which are shown in the table are the factory default settings.

4-8-4. Sewing long garments

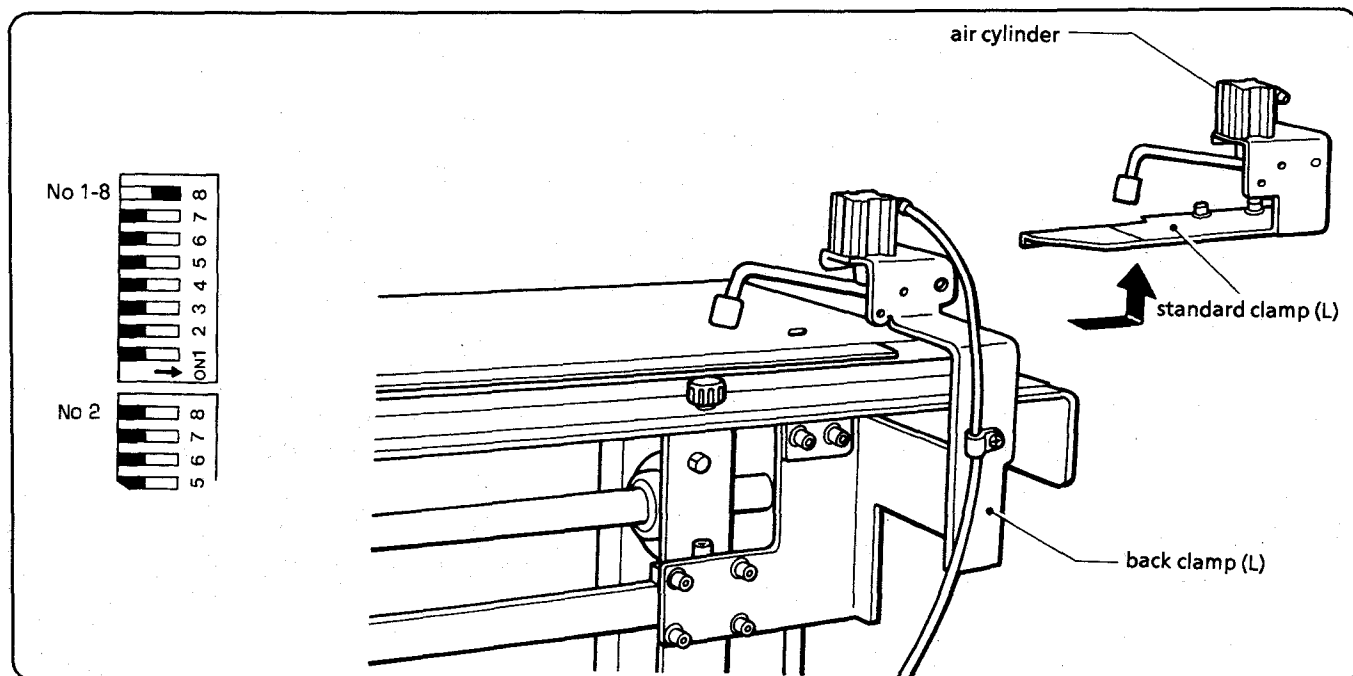

- When DIP switch No.1-8 on the operation panel is set to OFF, the maximum clamp feed amount will be 600 mm.
- When sewing long garments, replace the standard clamp (L) with the optional back clamp set (L) (S39274-001).

(NOTE)

- When replacing the clamp, be sure to replace the pneumatic cylinder also.
- When sewing long garments, set DIP switch No.1-8 on the operation panel to ON. The maximum feed amount will become 1150 mm.
- The clamps can move a maximum of 600 mm at one time. If they are made to move more than that, they will automatically be lifted up once and then lowered again. If this occurs in AUTOMATIC or feed only mode, the decimal point in the LED display will illuminate.

(NOTE)

- DIP switch No.1-8 on the operation panel should also be set to ON when setting a program for sewing long garments. If it is set to OFF, programming of feed lengths of longer than 600 mm will not be possible.
All DIP switches are set to OFF at the time of shipment from the factory.

4-9. One-pedal specifications

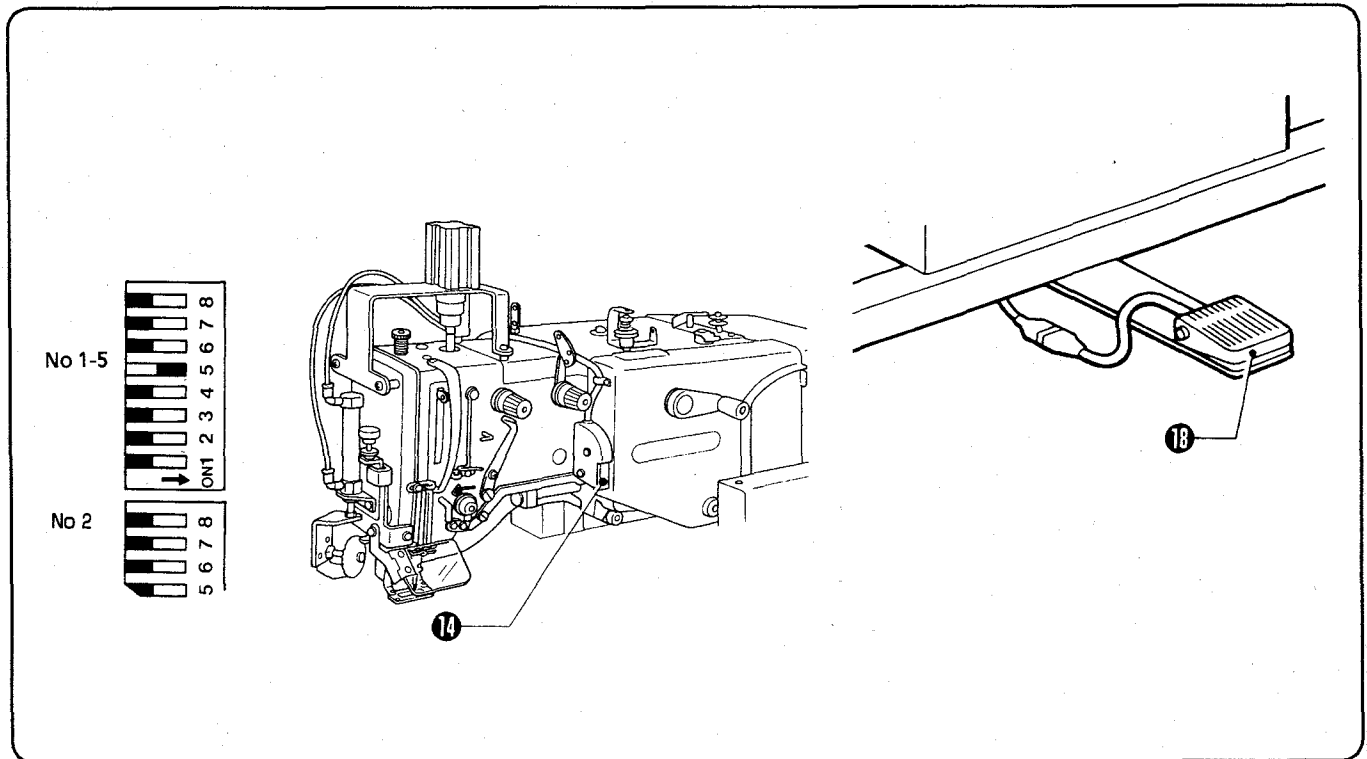

- One-pedal operation can be enabled by setting DIP switch No.1-5 on the operation panel to ON.

(NOTE)

- All DIP switches are set to OFF at the time of shipment from the factory.
- During one-pedal operation, the foot switch 18 and the start switch 16 both operate in the same way.
- Operations change in each mode as explained below depending on how the switches are depressed (or pressed).

{ AUTOMATIC }

If the foot switch is depressed slightly, the clamps are raised or lowered.

If the foot switch is depressed fully, the clamps are lowered and automatic sewing commences.

{ SEWING ONLY }

If the foot switch is depressed slightly, the cloth presser is raised or lowered.

If the foot switch is depressed fully, the cloth presser is lowered and one buttonhole is sewn.

{ FEED ONLY }

- At the material setting position

If the switches are (de)pressed slightly, the clamps are raised or lowered.

If the switches are (de)pressed fully, the clamps are lowered and automatic sewing commences.

- When the SEWING ONLY indicator is off in other than the material setting position

If the switches are (de)pressed fully, the clamps will move to the next buttonhole sewing position. (After the last buttonhole position is reached and the stacking operation is completed, the clamps return to the material setting position.)

- When the SEWING ONLY indicator is flashing in other than the material setting position

If the switches are (de)pressed slightly, the clamps are raised or lowered.

If the switches are (de)pressed fully, one buttonhole is sewn.

In addition, if the switches are (de)pressed fully, the clamps will move to the next buttonhole sewing position (after the buttonhole has been sewn as described above).

{ PROGRAM SET }

Not used

4-10. EMERGENCY switch/troubleshooting

4-10-1. Using the emergency stop function

- If the EMERGENCY switch ⑤ is pressed while the clamps are moving, they will keep moving to the next position and then stop, and the EMERGENCY indicator will illuminate.
- If the EMERGENCY switch ⑤ is pressed while sewing is being carried out, the machine will stop after one cycle is completed, and then stop, and the EMERGENCY indicator will flash. The cutter will not operate at this time.

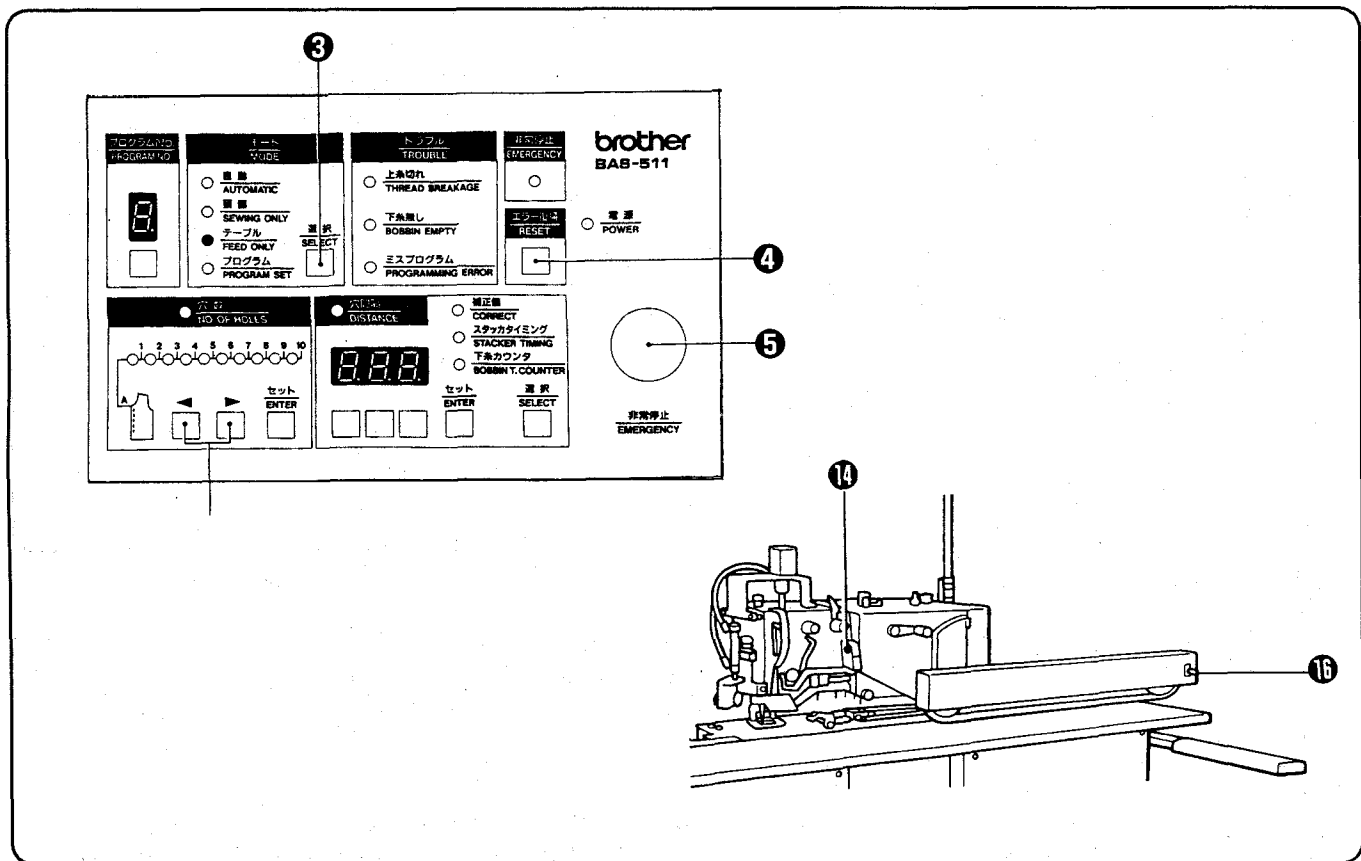

To restart

1. If the EMERGENCY switch (⑤ is pressed while the clamps are moving (EMERGENCY indicator is illuminated)
 - If you would like to keep sewing from the stopped position, press the RESET switch ④ (the EMERGENCY indicator will switch off), and then press the start switch ⑭. The remaining buttonholes will be sewn automatically.
 - If you would like to stop sewing and return the clamps to the home position, press the RESET switch ④ (the EMERGENCY indicator will switch off), and then press the EMERGENCY switch ⑤ once more. The EMERGENCY indicator will illuminate and the clamps will be raised. Then press the start switch ⑭. Positioning will be carried out, and the clamps will then return to the home position.
 - If you would like to start sewing again from the position one buttonhole before the stop position, press the RESET switch ④ (the EMERGENCY indicator will switch off). Then press the ◀ arrow switch ③. The clamps will move back to the previous buttonhole position. Press the start switch ⑭. Sewing will then be carried out automatically from that position. (NOTE) However, the sewing position cannot be moved back in this way when sewing long garments.
 - If you would like to stop sewing and just stack the workpiece, press the RESET switch ④ (the EMERGENCY indicator will switch off), and then press the MODE switch ③. The FEED ONLY indicator will illuminate and the mode will switch to feed only mode. Then press the start switch ⑭. The clamps will move to the final buttonhole position. Press the start switch ⑭ once more. If the stacker switch ⑮ is on, the stacker will operate and the clamps will return to the material setting position.

2. If the EMERGENCY switch ((5 is pressed while sewing is being carried out (EMERGENCY indicator is flashing)

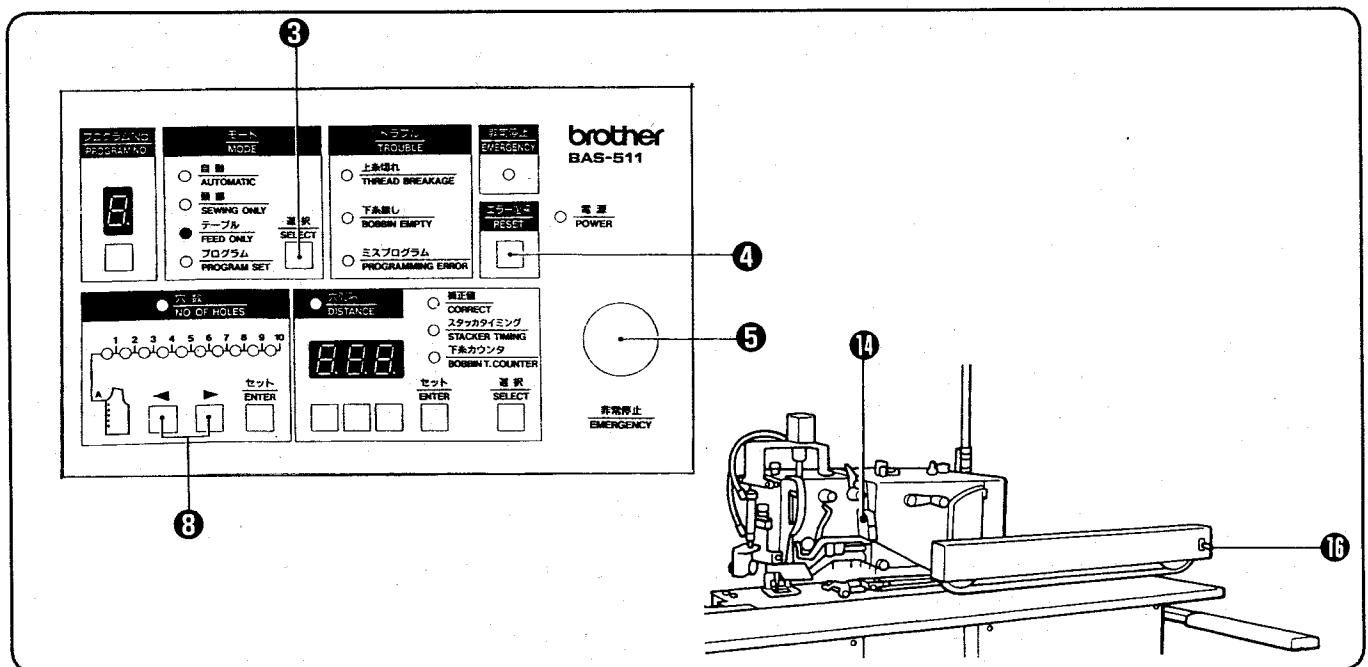

- If you would like to continue sewing from the stopped position, press the RESET switch ④ (the EMERGENCY indicator will be illuminated), and then press the start switch ⑭. The remaining buttonholes will be sewn automatically.
- If you would like to start sewing again from the next buttonhole position, press the RESET switch ④ once (the EMERGENCY indicator will be illuminated), and then press it once more. The upper clamping foot will be raised and the EMERGENCY indicator will switch off. Then press the start switch ⑭. The clamps will move to the next buttonhole position and the remaining buttonholes will be sewn automatically.
- If you would like to start sewing again from the position one buttonhole before the stop position, press the RESET switch ④ once (the EMERGENCY indicator will be illuminated) and then press it once more. The upper clamping foot will be raised and the EMERGENCY indicator will switch off. Then press the ◀ arrow switch ③. The clamps will move back to the previous buttonhole position. Press the start switch ⑭. Sewing will then be carried out automatically from that position.
(NOTE) However, the sewing position cannot be moved back in this way when sewing long garments.
- If you would like to stop sewing and return the clamps to the home position, press the RESET switch ④ once (the EMERGENCY indicator will illuminate), and then press it once more. The upper clamping foot will be raised and the EMERGENCY indicator will switch off. Then press the EMERGENCY switch ⑤. The EMERGENCY indicator will illuminate and the clamps will be raised. Then press the start switch ⑭. Positioning will be carried out, and the clamps will then return to the home position.
- If you would like to stop sewing and just stack the workpiece, press the RESET switch ④ once (the EMERGENCY indicator will illuminate), and then press it once more. The upper clamping foot will be raised and the EMERGENCY indicator will switch off. Then press the MODE switch ③. The FEED ONLY indicator will illuminate and the mode will switch to feed only mode. Then press the start switch ⑭. The clamps will move to the final buttonhole position. Press the start switch ⑭ once more. If the stacker switch ⑮ is on, the stacker will operate and the clamps will return to the material setting position.
(NOTE)
If the EMERGENCY switch ⑤ is pressed after a sewing cycle has been completed and the machine is in the deceleration range, it will stop with the material presser raised and the EMERGENCY indicator will illuminate. In this case it is not possible to sew at the same place again. Restarting is carried out in the same way as when the EMERGENCY switch ((5 is pressed while the clamps are moving.

4-10-2. If a TROUBLE indicator illuminates**1. Needle thread breakage**

If the needle thread breaks while sewing, the UPPER THREAD BREAKAGE indicator will light, the EMERGENCY STOP indicator will blink, and the machine will stop automatically after one cycle is completed.

- **To restart**

Thread the needle thread.

Subsequent operations are the same as that given in "2. If the EMERGENCY switch  is pressed while sewing is being carried out" on page 29.

2. BOBBIN EMPTY

If the bobbin thread counter drops so low that it is not possible to sew a single workpiece in automatic mode, or if the counter drops to "0" in sewing only mode, the BOBBIN EMPTY and EMERGENCY indicators illuminate and further sewing will not be possible. If this happens, press the RESET switch  to switch off the indicators and reset the bobbin thread counter. (Refer to "4-1. Setting the bobbin thread counter" on page 31.)

3. PROGRAMMING ERROR

If a value which exceeds the limit range is input while creating a program in program set mode, the PROGRAMMING ERROR indicator will illuminate.

(NOTE) or further details, refer to "4-3. Program input" on page 12.

4-11. Setting the thread counter

When the clamps are at the material setting position in automatic mode, and when in sewing only mode, the bobbin thread counter indicates the number of buttonholes that can be sewn on the LED display.

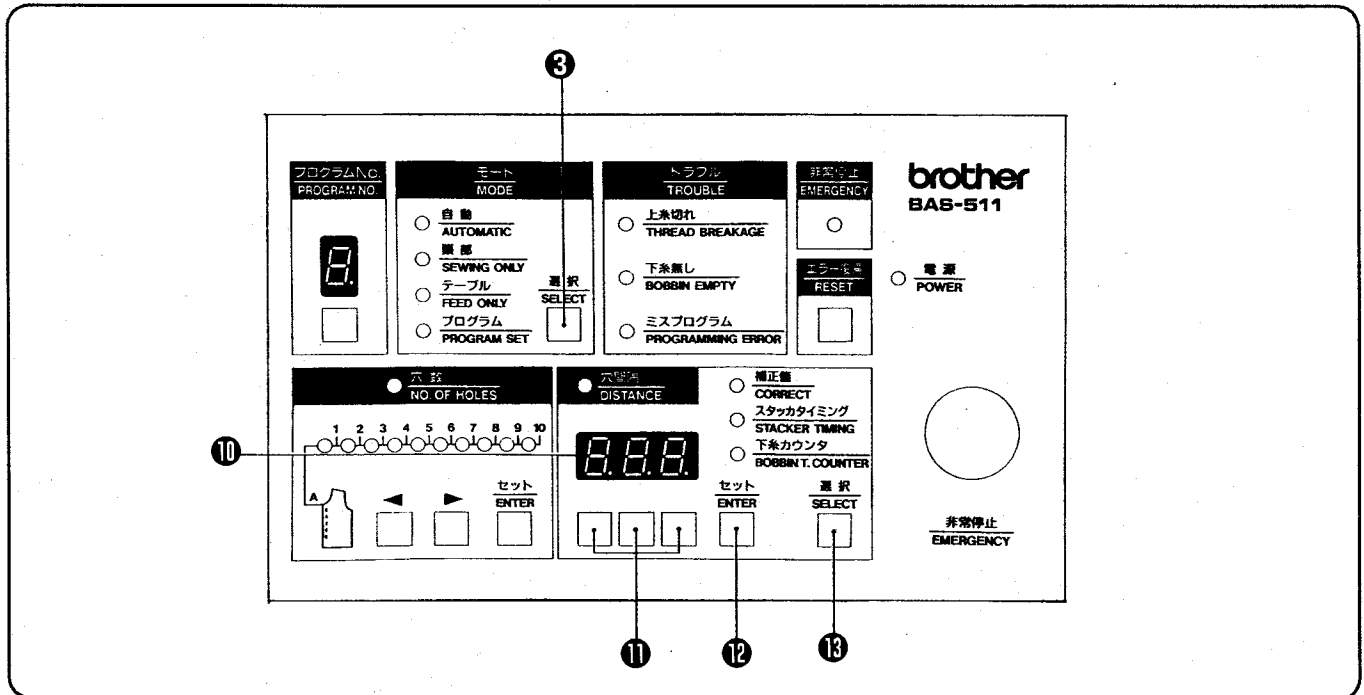

Setting method

1. Set the MODE selector ③ to AUTOMATIC or SEWING ONLY.
2. Change the bobbin.
3. Press the SELECT switch ⑬.
The BOBBIN T. COUNTER indicator will start to flash and the bobbin thread counter value which was previously set will be indicated on the LED display ⑩.
4. If the needle, thread or buttonhole width has been changed, press the LED display setting switches ⑪ to set the number of buttonholes that can be sewn for a single bobbin.
5. Press the DISTANCE ENTER switch ⑫.
The BOBBIN T. COUNTER indicator will illuminate and the new bobbin thread counter setting value will be recorded.

(NOTE)

- If the SELECT switch ⑬ is pressed before the DISTANCE ENTER ⑫ switch is pressed, the bobbin thread counter setting mode will be canceled and the setting value will not be updated.
- When in automatic mode, you cannot enter a value which is lower than the number of buttonholes which has been set in the current program.
- If "0" is set, the bobbin thread counter will not be decremented after a buttonhole is sewn.

4-12. Setting the correction value

In cases where the finished sewing dimensions may become smaller than the dimensions which have been input into the program as a result of puckering, the correction function uses a correction value which you can specify to ensure that the finished sewing dimensions and the programmed dimensions end up being the same.

In the case shown in the illustration below, when using a program which sews five buttonholes at 100-mm intervals (for a total of 400 mm), the actual interval between buttonholes when sewing continuously has become 99 mm (for a total length of 396 mm). By entering a correction value of 4.0 mm, the clamp is moved by an extra 1.0 mm for each interval ($4.0 \text{ mm} - \text{no. of intervals } 4$). As a result, the finished dimensions remain equal to the programmed dimensions.

For uneven intervals too, the value added to each interval equals the correction value divided by the number of intervals.

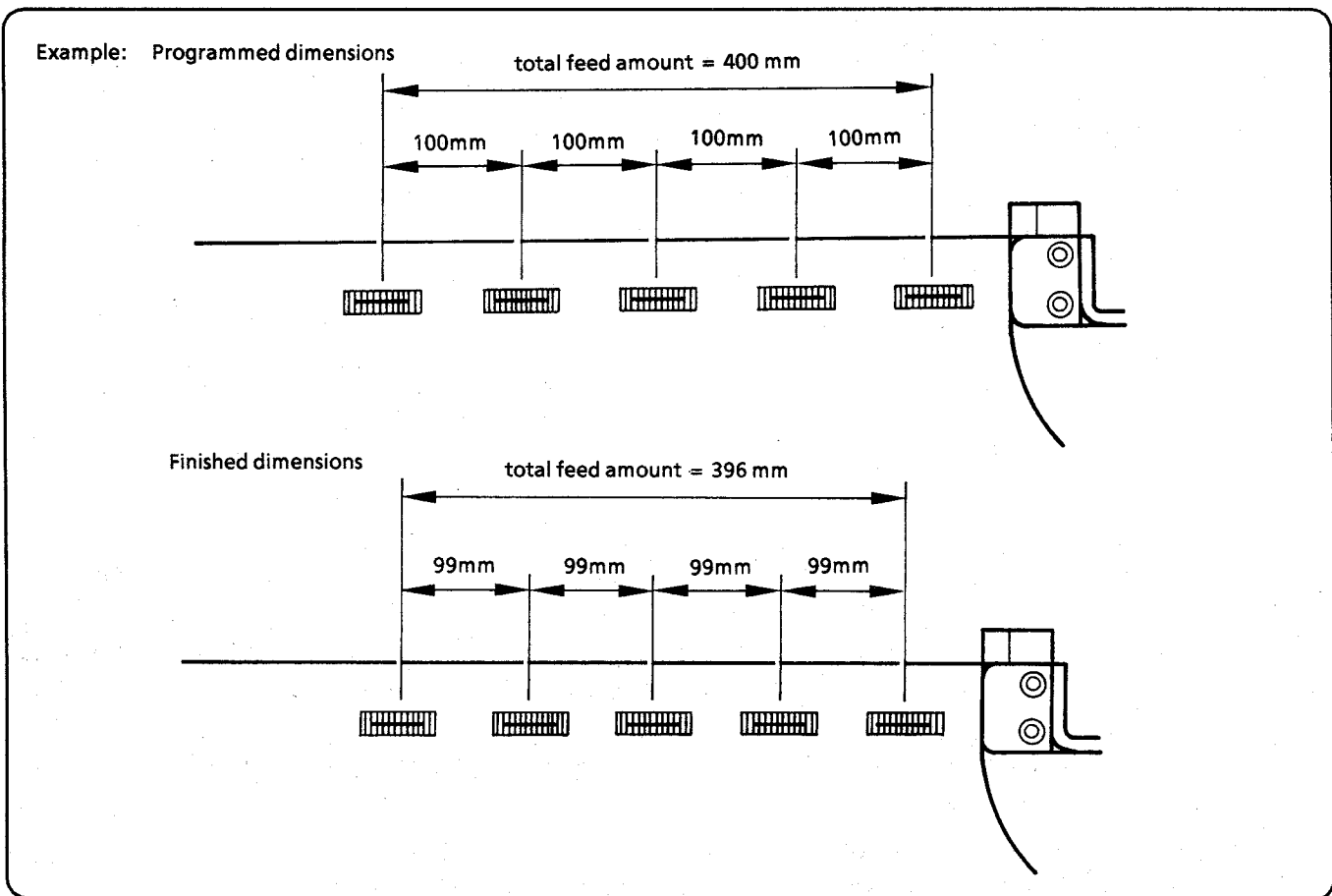

The correction value can be set by entering it into a program in program set mode, or when the clamps are at the material setting position in automatic mode.

Setting method for automatic mode

[NOTE]

- For details on setting in program set mode, refer to page 12, 13.

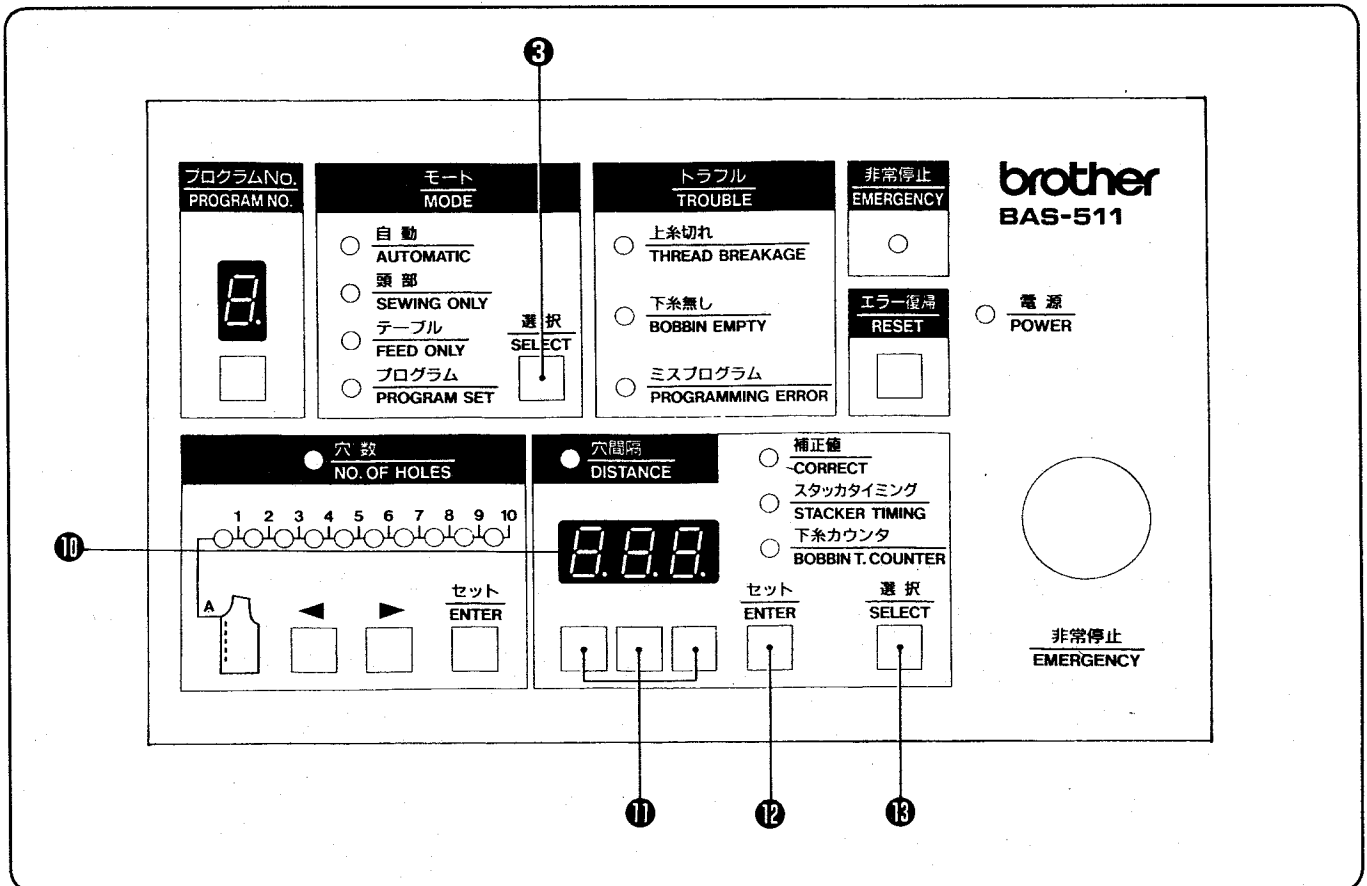

1. Press the MODE switch ③ to switch to automatic mode.
 2. Press the SELECT switch ⑬ three times.
The CORRECT indicator will illuminate and the correction value which was previously set will be indicated on the LED display ⑩.
 3. Press the LED display setting switches ⑪ to set the correction value.
 - The value can be set to between 0.0 - 5.5 mm in steps of 0.5 mm.
 - When a new program is created, the correction value defaults to 0.0 mm.
 4. Press the DISTANCE ENTER switch ⑫.
The display will change to the bobbin thread counter display and the correction value will be recorded.
- [NOTE]
- If the SELECT switch ⑬ is pressed before the DISTANCE ENTER ⑫ switch is pressed, the correction value setting mode will be canceled and the setting value will not be updated.

4-13. Clamp L adjustment

4-13-1. When sewing men's clothing

[-* -] (* = 0, 1, ... 9, A) will appear on the LED display in automatic or feed only mode after the power has been turned on or after a program has been changed.

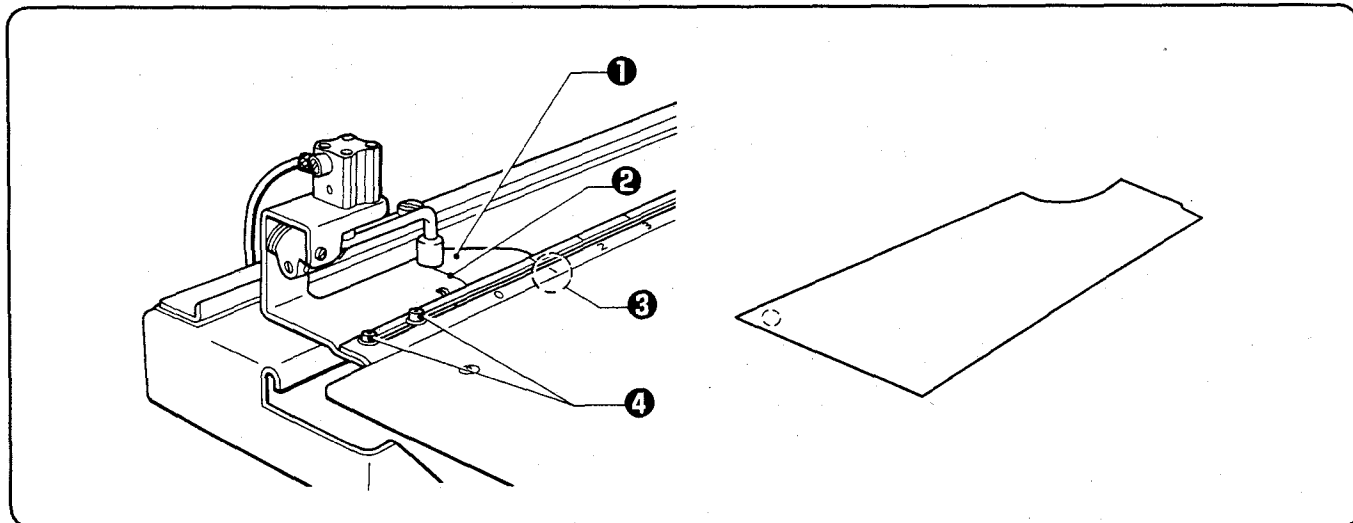

1. Set clamp (L) ① to a position that is to the left of the displayed position, or to the position where the material is being pressed securely.
(For example, if the display reads "[-1-]", set clamp (L) ① so that the reference line ② is to the left of the "1" mark ③, and then secure it with the bolt ④.)
2. Press the RESET switch ⑤. The display will change to show the bobbin thread counter or stacker timing setting.

(NOTE)

- Clamp (L) ① should be set to as far away from the machine as possible.
- The bolt ④ should be kept securely tightened at all times except when moving clamp (L) ①.

4-13-2. When sewing ladies' clothing

[-* -] (* = 0, 1, ... 9, A) will appear on the LED display in automatic or feed only mode after the power has been turned on or after a program has been changed.

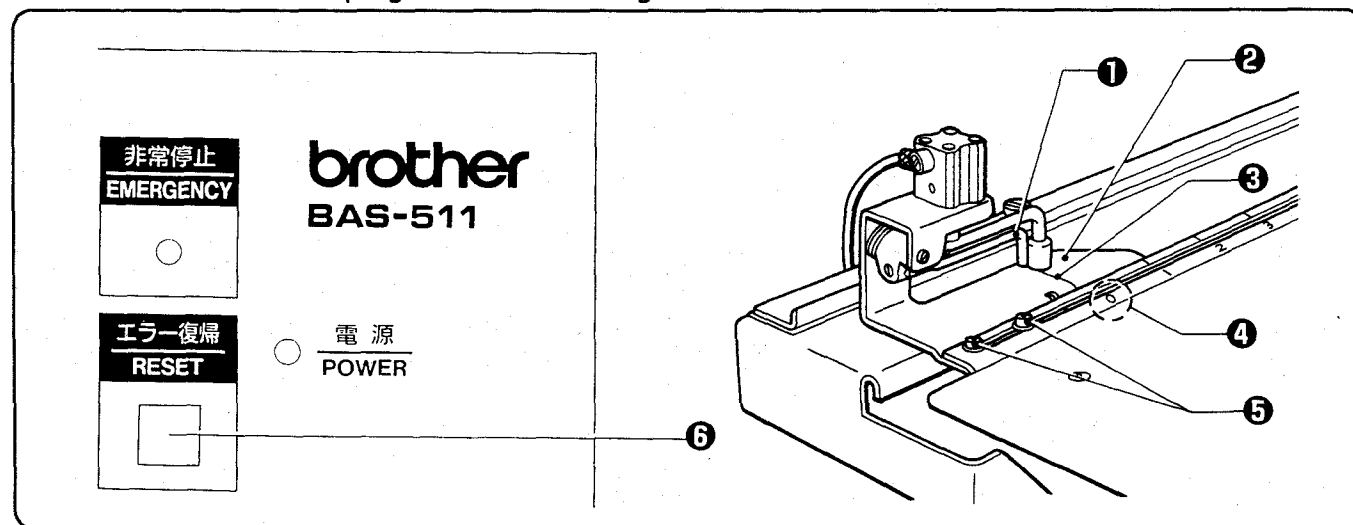

1. Install the ladies' garment guide ①. (Refer to page 20.)
2. Set clamp (L) ② to the indicated position.
(For example, if the display reads "[-0-]", set clamp (L) ② so that the reference line ③ is to the left of the "0" mark ④, and then secure it with the bolt ⑤.)
3. Press the RESET switch ⑥. The display will change to show the bobbin thread counter or stacker timing setting.

4-14. Leading edge guide timing adjustment

4-14-1. Edge guide operation

- The edge guide will always be raised when sewing ladies' garments.
- The leading edge guide ① will be raised after the first buttonhole is sewn when in the MEN'S garment mode and the MODE selector is at AUTOMATIC.
The leading edge guide will descend again when:
 - * The stacker switch ⑫ is turned on
The leading edge guide will descend after the stacker roller carries the material to the stacker and material is placed under the leading edge guide.
 - * If the stacker switch is OFF
The leading edge guide will descend approximately 2 seconds after sewing is completed. Remove the material before the leading edge guide descends.
- When the leading edge guide descends, the next workpiece can be set and sewing can be started even if the stacker is still operating.
- Set the MODE selector to SEWING ONLY to remove the material if the leading edge guide descends and clamps the material. The leading edge guide will rise.

4-14-2. Setting the edge guide timing

- * If the distance between the final buttonhole position and the edge of the material is longer than 250 mm
Set DIP switch No.1-6 on the operation panel to OFF.
- * If the distance between the final buttonhole position and the edge of the material is 250 mm or less
Set DIP switch No.1-6 on the operation panel to ON.

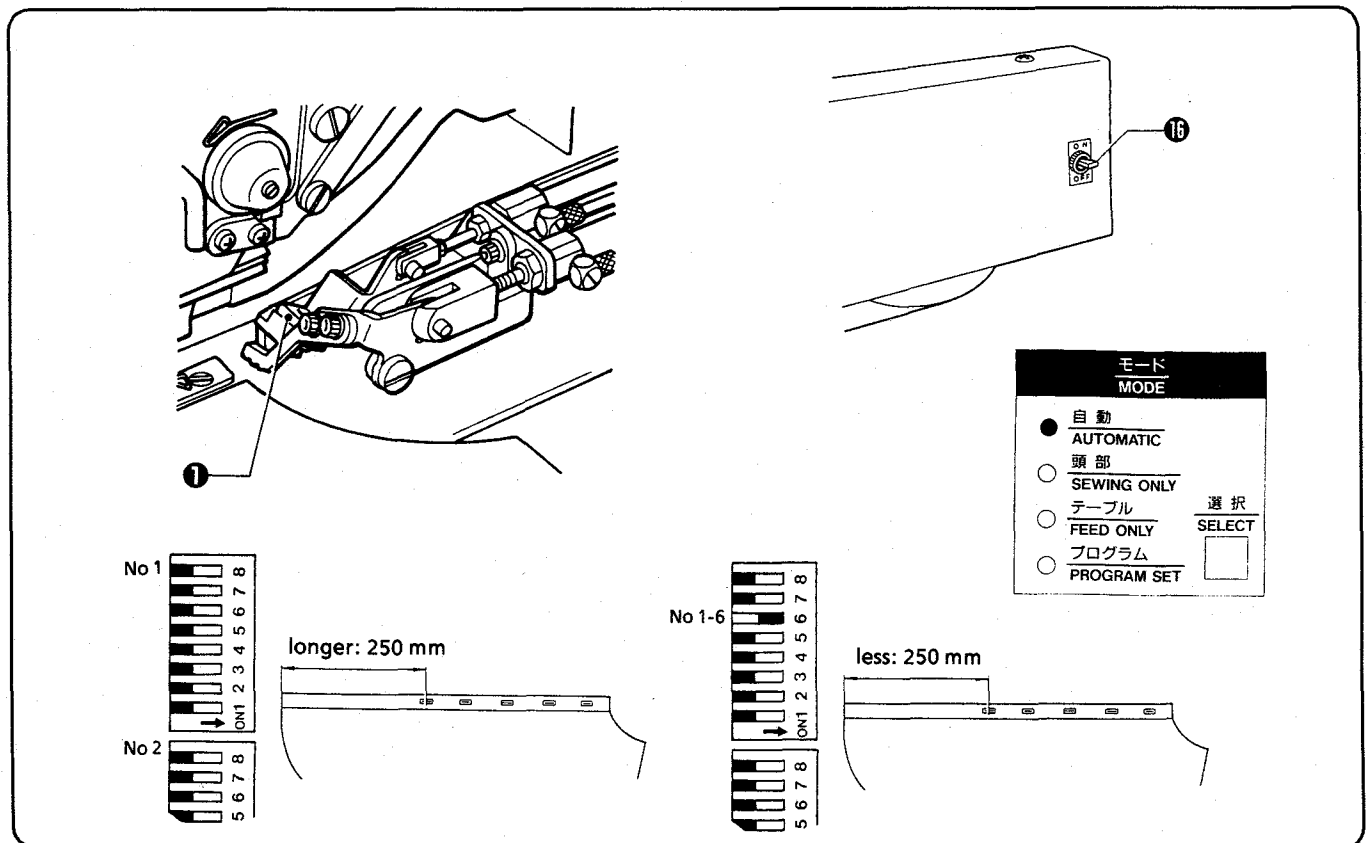

4-15. Using the stacker

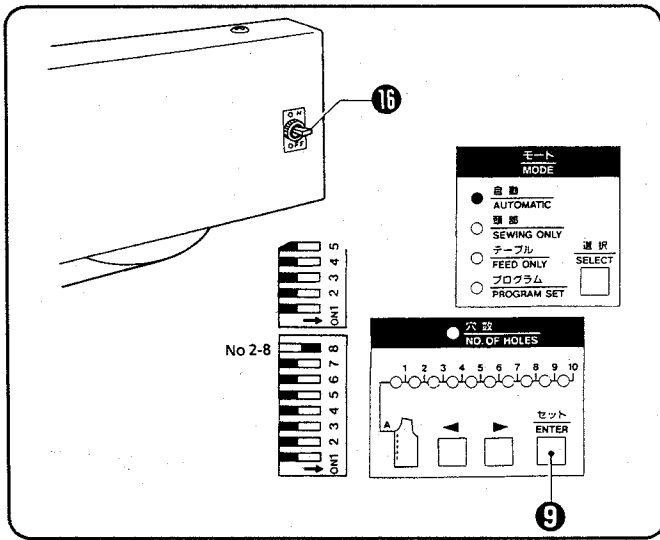

1. When using the stacker, set DIP switch No.2-8 on the operation panel to ON and then turn on the power.
Turn the stacker motor and flex the belt to loosen it. Furthermore, wipe the belt clean with a cloth at this time. When the start switch is pressed, the machine will move to the home position.
2. Turn the stacker switch 16 on.
After sewing is completed, the stacker will operate and the workpiece will be draped on the stacker.
3. Turn the stacker switch 16 off to remove the material from the stacker.
* When the clamp is in the material set position when in the AUTOMATIC mode, the stacker can be operated alone by pressing ENTER 9.

◀Stacker timing adjustment▶

- The stacker timing is automatically calculated and stored when dimension A, the number of holes, and the distance are set in the PROGRAM mode and the MODE selector is then reset away from PROGRAM. However, the stacker timing is calculated assuming a standard pattern design, and when sewing non-standard patterns the workpiece may not be evenly stacked as shown below.

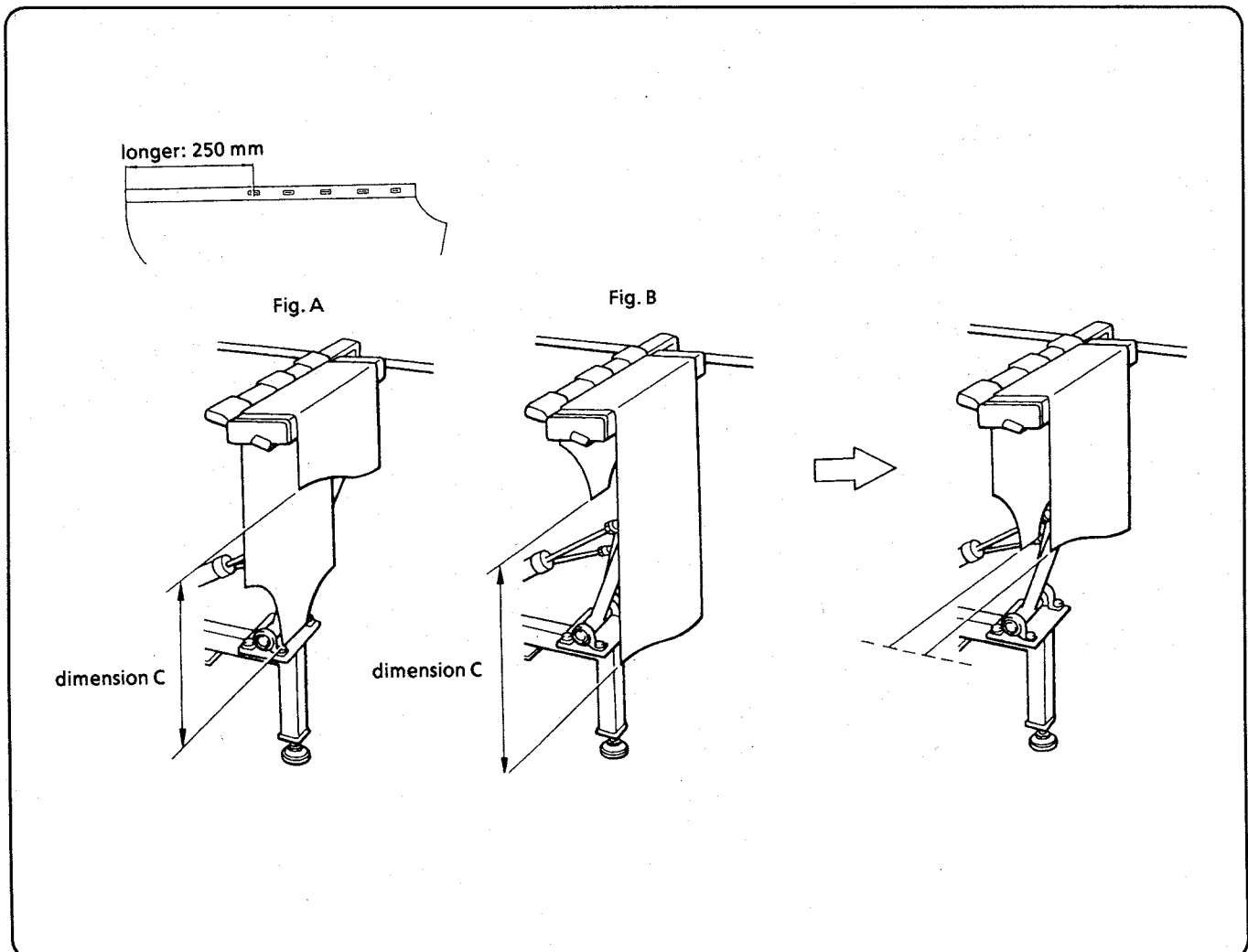

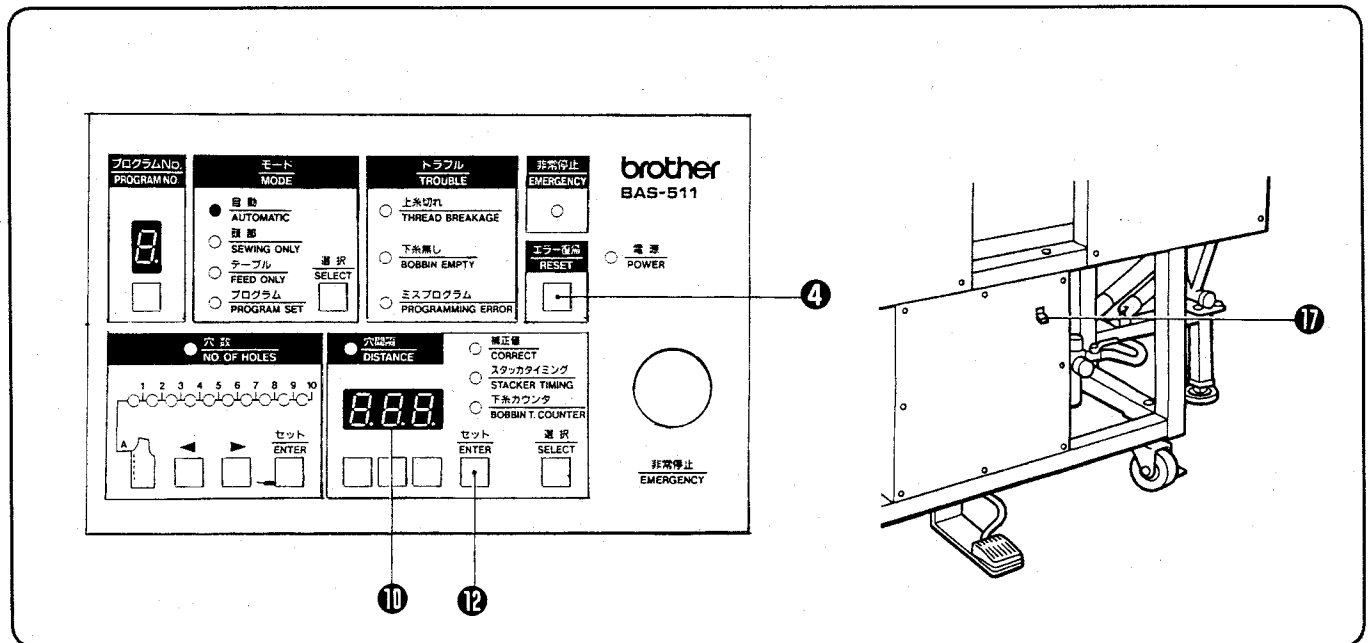

● Adjustments can be made as follows if the material is particularly uneven when the material is draped over the stacker.

1. Press the SELECT switch ⑬ twice if the machine is in automatic mode and the clamps are at the material setting position, or once if the machine is in feed only mode and the clamps are at the material setting position.
The STACKER TIMING indicator will start to flash and the stacker timing will be shown on the LED display ⑩ in millimeter units.

2. Press the LED display setting switches ⑪ to set the stacker timing value.

If the material drapes as in Fig. A, DECREASE the displayed timing.

If the material drapes as in Fig. B, INCREASE the displayed timing.

The displayed number indicates millimeters (mm).

If in Fig. A, dimension C = 100 mm, increase the display by $100 \div 2 = 50$ mm.

If in Fig. B, dimension C = 100 mm, decrease the display by $100 \div 2 = 50$ mm.

3. Press the DISTANCE ENTER switch ⑫. The stacker timing setting will then be recorded.

(NOTE)

- If a value between 0 - 199 is set, the setting will automatically be changed to 200.

4-16. Sewing counter

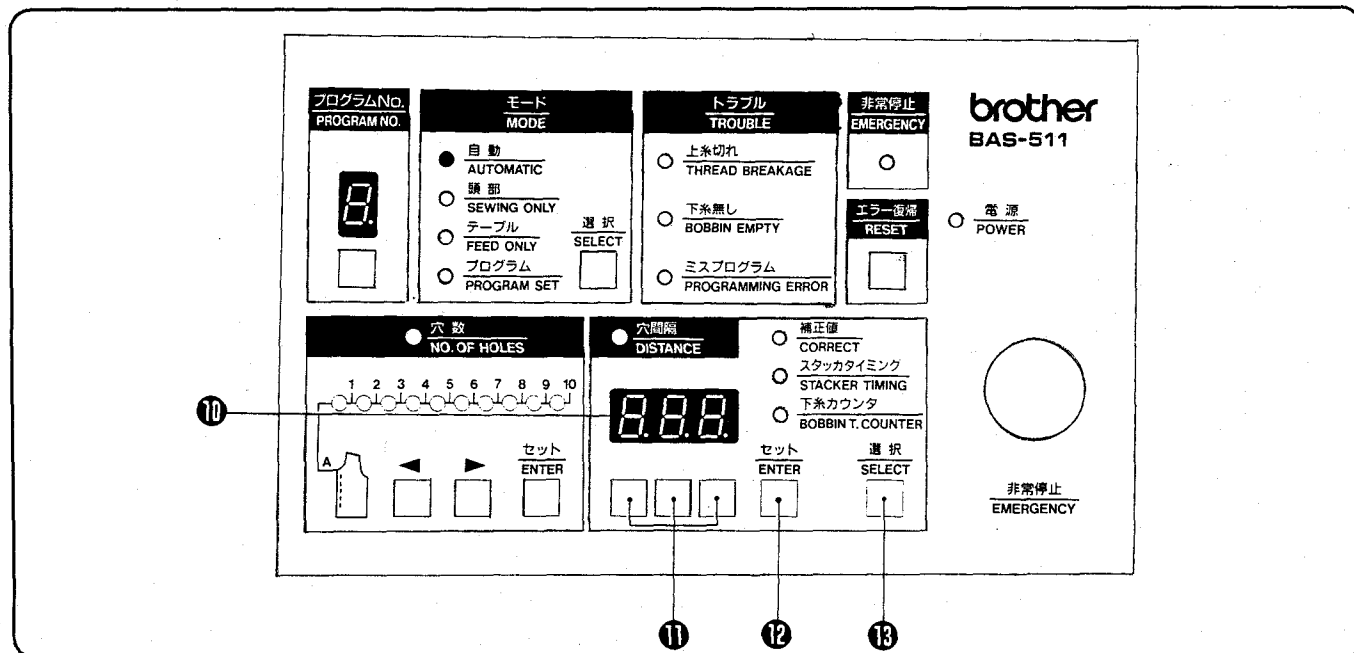

- When the clamps are at the material setting position in automatic mode, the production counter value appears on the LED display ⑩ as a value from 0 - 999 while the DISTANCE ENTER switch ⑫ is being pressed.
- The production counter is incremented by 1 each time one piece of material is sewn in automatic mode. When the counter reaches 999, it is reset to 0.
- If you would like to clear the production counter (reset it to 0), press the DISTANCE ENTER switch ⑫, and while the production counter is being displayed, press the RESET switch ④.
- The production counter setting is retained even when the power switch ⑰ is turned off.

4-17. To change the buttonhole size

- When replacing the upper clamping foot or the cutter, set the DIP switches on the operation panel as shown in the table below. If the machine is used with the DIP switches at incorrect settings, the home position will become displaced and correct sewing will not be possible.
- The possible ranges for the sewing data will be limited by the sizes of the upper clamping foot and cutter.

DIP switch positions and data limit values for different upper clamping foot and cutter sizes



No.	Cutter size (buttonhole length)	Gauge size	Minimum distance A	Maximum feed amount	Panel DIP switches				Upper limit of A + C *
					2-1	2-2	2-3	2-4	
1	11.11 mm · 7/16 inch (15.71 mm)	Small (12.7mm)	55 mm (45 mm)	600 mm	ON				655 mm (645 mm)
2	12 mm (16 mm)	Medium (16 mm)	55 mm (45 mm)	600 mm		ON			655 mm (645 mm)
3	13 mm (17 mm)	Medium (16 mm)	55 mm (45 mm)	600 mm			ON		655 mm (645 mm)
4	12.7 mm · 1/2 inch (17.3 mm)	Medium (16 mm)	55 mm (45 mm)	600 mm				ON	655 mm (645 mm)
5	14.3 mm · 9/16 inch (18.9 mm)	Medium (16 mm)	60 mm (50 mm)	590 mm	ON	ON			650 mm (640 mm)
6	15.87 mm · 5/8 inch (20.47 mm)	Medium (16 mm)	60 mm (50 mm)	590 mm	ON		ON		650 mm (640 mm)
7	19.05 mm · 3/4 inch (23.65 mm)	Large (25 mm)	65 mm (55 mm)	580 mm	ON			ON	645 mm (635 mm)
8	22.225 mm · 7/8 inch (26.82 mm)	Large (25 mm)	65 mm (55 mm)	580 mm		ON	ON		645 mm (635 mm)
9	11.11 mm · 7/16 inch (15.74 mm)	Medium (16 mm)	60 mm (50 mm)	590 mm		ON		ON	650 mm (640 mm)



* Upper limit of distance A + total feed amount

Values in brackets are for when the minimum distance A is 45 mm (when men's garments are being sewn) and when ladies' garments are being sewn.

! CAUTION

- 
 - Turn off the power switch and disconnect the power cord from the wall outlet at the following times, otherwise the machine may operate if the start switch or the foot switch is pressed by mistake, which could result in injury.
 - When carrying out inspection, adjustment and maintenance
 - When replacing consumable parts such as the rotary hook and knife
 - change gauge parts
- 
 - Disconnect the air hoses from the air supply and wait for the needle on the pressure gauge to drop to "0" before carrying out inspection, adjustment and repair of any parts which use the pneumatic equipment.
- 
 - Use only the proper replacement parts as specified by Brother.

- Follow the procedure below to change gauge parts.

1. Loosen screw ①, and remove needle ②.
2. Remove screw ③, and remove cutter ④.
3. Remove presser foot adjustment screw ⑤.
4. Manually raise length feed arm ⑥, and place a block under the arm ⑥.
5. Remove screw ⑧, and remove material clamp ⑦. (Be careful not to lose spring ⑭.)
6. Remove thumbscrew ⑨, and remove vertical ruler ⑩.
7. Remove screw ⑪, and remove needle plate ⑫.

(NOTE)

- When using a horizontal cutter, replace the base needle plate ⑬. Install in the reverse order to removal, while making careful note of the cautions on installation.

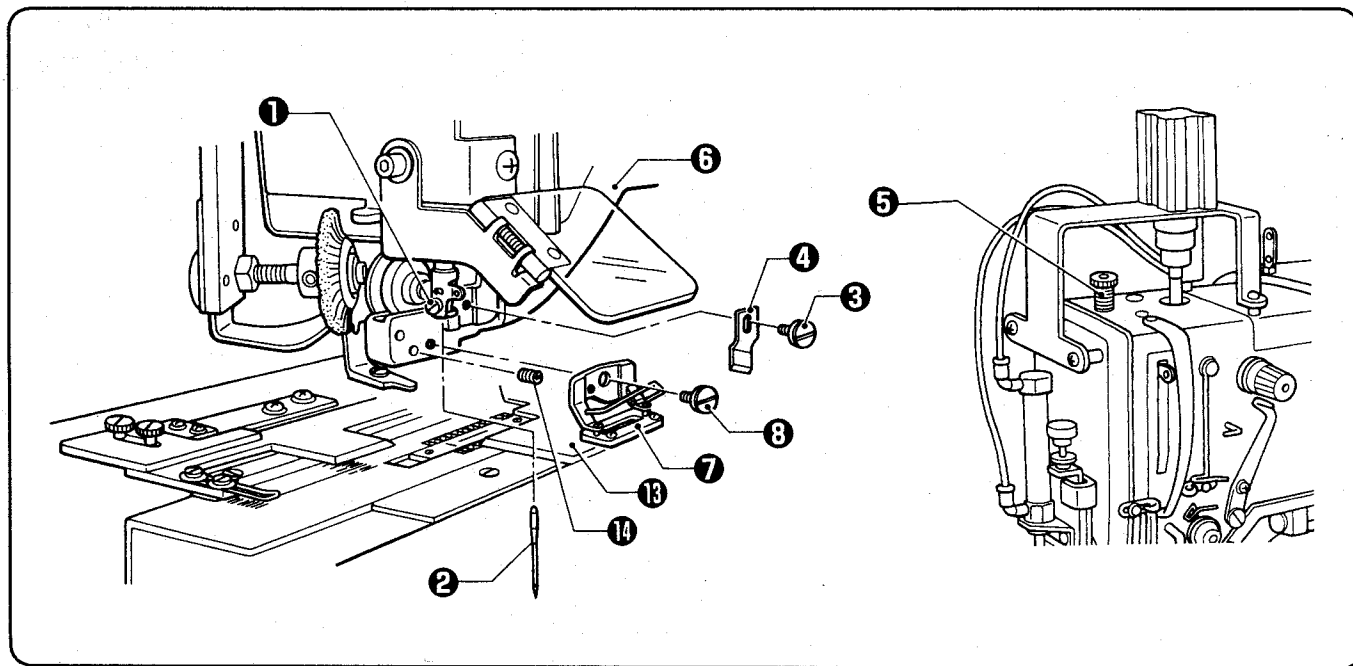

4-18. Changing the clamp (R) installation position

⚠ CAUTION



- Turn off the power switch before starting any cleaning work, otherwise the machine may operate if the start switch or the foot switch is pressed by mistake, which could result in injury.

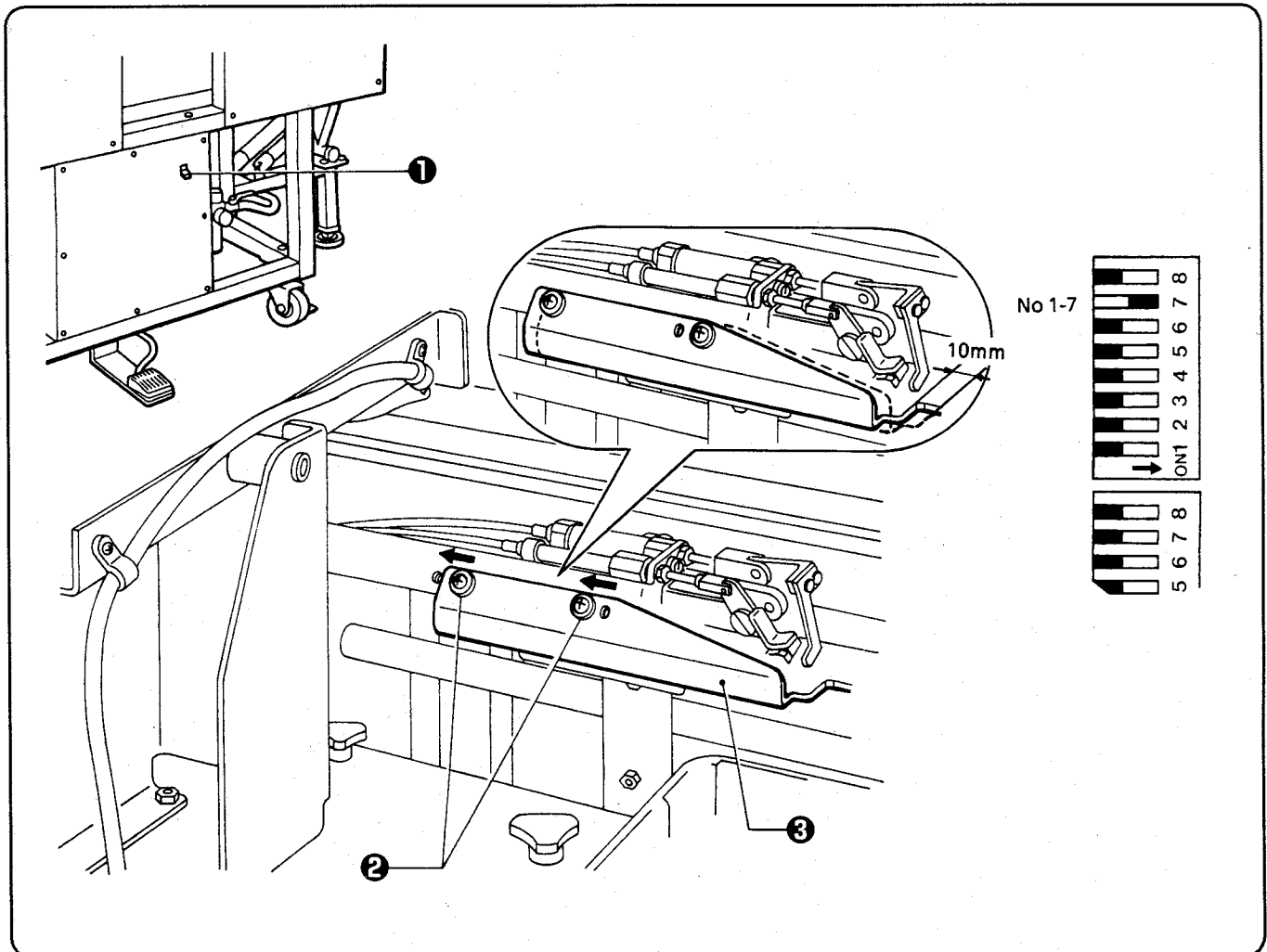

1. Turn on the power switch ①.
2. Set DIP switch No.1-7 on the operation panel to ON.
3. Remove the two screws ② and move clamp (R) ③ 10 mm to the left.

When the minimum distance A has been set to 45 mm when sewing men's garments, or when sewing ladies' garments

Clamp (R) can be moved 10 mm to the left and then installed.

After it is moved 10 mm to the left, the minimum distance A will be reduced by 10 mm.

4-19. Error code list

- If an error message is displayed during sewing, refer to the table below for the necessary remedy.

Error code	Details of error	Remedy
E1	Start switch is on when power is turned on.	Turn power off
E2	Foot switch is on when power is turned on.	Turn power off
E3	EMERGENCY switch is on when power is turned on.	Turn power off
E4	Feed motor problem (communication error with motor circuit board)	Turn power off
E5	Incorrect cutter or gauge size setting	Turn power off
E6	Stop sensor does not turn on when not sewing. (sensor malfunction, incorrect adjustment or handle was turned)	Turn power off
E7	Distance A in program is smaller than minimum distance A allowed by panel DIP switch setting.	RESET switch
E8	Cutter sensor does not turn on. (sensor malfunction, incorrect adjustment or cutter has dropped)	Turn power off
E9	Pneumatic feed does not finish within allotted time. (mechanical contact, fuse F3 on power supply circuit board is blown, or feed motor or printed circuit board malfunction)	Turn power off
E10	Corrupt program data	Turn power off
E11	Distance A + distance D + correction value in program is larger than maximum feed amount allowed by panel DIP switch setting.	RESET switch
E12	Servo sensor error (Either servo sensor is not on when power is turned on, or both sensors are off during sewing.)	RESET switch Turn power off
E13	Machine error when sewing completed. (overrun error, upper clamping foot malfunction, etc.)	RESET switch
E14	Upper clamping foot operation problem (Upper clamping foot operation problem, upper clamping foot sensor switch malfunction or no air)	Turn power off
E15	Machine does not start. (Stop signal does not turn off even when machine is turned on.)	Turn power off
E16	Sewing does not stop. top signal does not switch on 7 seconds after sewing starts.)	Turn power off
E17	Table feed or ladies' garment sewing and long garment sewing are set simultaneously.	Turn power off

(NOTE) If the error code is flashing, the error cannot be reset unless the power is turned off.
If the error code is illuminated, remove the cause of the error, and then press the RESET switch.

brother®

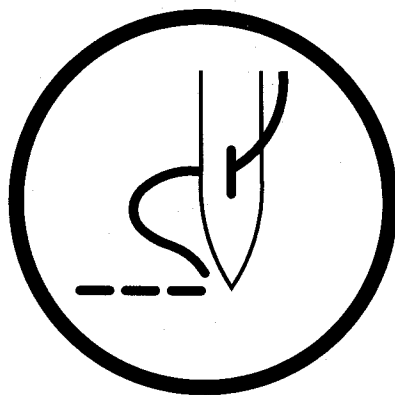

INSTRUCTION MANUAL

BROTHER INDUSTRIES, LTD. NAGOYA, JAPAN

Printed in Japan

151-511
S93511-002
1995. 12. H ①

Free Manuals Download Website

<http://myh66.com>

<http://usermanuals.us>

<http://www.somanuals.com>

<http://www.4manuals.cc>

<http://www.manual-lib.com>

<http://www.404manual.com>

<http://www.luxmanual.com>

<http://aubethermostatmanual.com>

Golf course search by state

<http://golfingnear.com>

Email search by domain

<http://emailbydomain.com>

Auto manuals search

<http://auto.somanuals.com>

TV manuals search

<http://tv.somanuals.com>